

# ICS649-check

## Weighing terminals

### Terminal and platform combinations

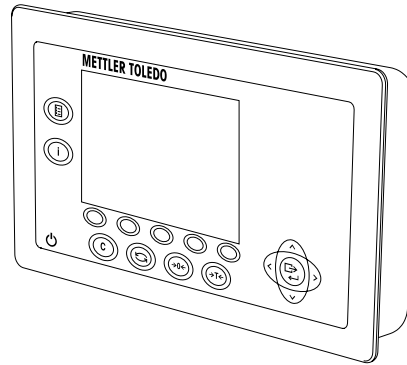

ICS649a-check  
ICS649d-check

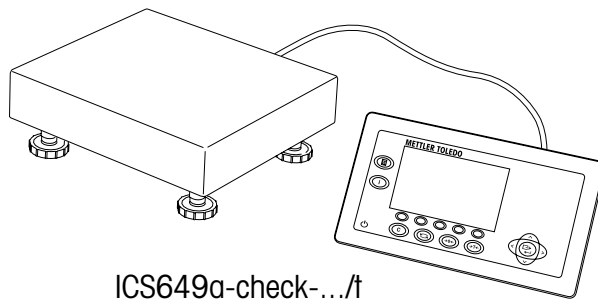

ICS649a-check-.../f

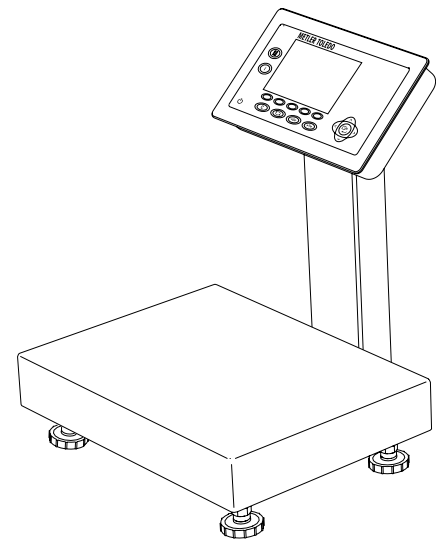

ICS649a-check-.../c

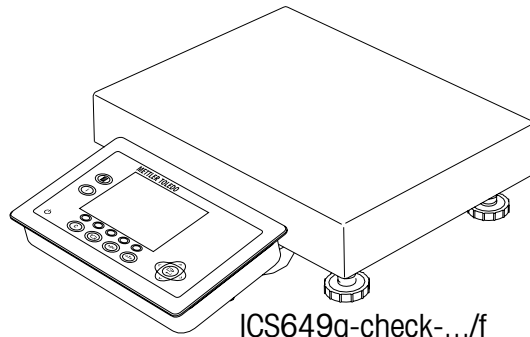

ICS649a-check-.../f

# ServiceXXL

## Tailored Services

Congratulations on choosing the quality and precision of METTLER TOLEDO. Proper use according to these instructions and regular calibration and maintenance by our factory-trained service team ensure dependable and accurate operation to protect your investment. Contact us about a ServiceXXL agreement tailored to your needs and budget.

We invite you to register your product at

[www.mt.com/productregistration](http://www.mt.com/productregistration)

so we can contact you about enhancements, updates and important notifications concerning your METTLER TOLEDO product.

# Contents

<b>1</b>	<b>Introduction.....</b>	<b>5</b>
1.1	Safety instructions .....	5
1.2	Presentation.....	6
1.3	Tracing and tracking features .....	16
1.4	Commissioning .....	18
1.5	Use in hygienically sensitive areas.....	20
<b>2</b>	<b>Operation.....</b>	<b>21</b>
2.1	Switching on and off .....	21
2.2	Zeroing / Zero point correction .....	22
2.3	Simple weighing .....	22
2.4	Weighing with tare.....	22
2.5	Switching scales.....	24
2.6	Printing results .....	24
2.7	Totalising .....	25
2.8	Average (dynamic) weighing.....	27
2.9	Piece counting .....	27
2.10	Working with identifications .....	29
2.11	Displaying information .....	29
2.12	Environment and cleaning .....	30
2.13	Verification test.....	32
<b>3</b>	<b>Over/Under Checkweighing .....</b>	<b>33</b>
3.1	Specifying target values.....	33
3.2	Over/Under Checkweighing procedure.....	36
3.3	Over/Under Checkweighing during subtractive weighing.....	38
3.4	Over/Under Checkweighing with "Quick start" .....	39
3.5	Over/Under Checkweighing in Take-away mode .....	40
3.6	Over/Under Checkweighing to zero .....	41
3.7	Terminating Over/Under Checkweighing .....	42
<b>4</b>	<b>Settings in the menu.....</b>	<b>43</b>
4.1	Operating the menu .....	43
4.2	Scale menu block – analog scales .....	46
4.3	Scale menu block – IDNet scales .....	49
4.4	Application menu block.....	52
4.5	Terminal menu block.....	56
4.6	Communication menu block.....	62
4.7	Maintenance menu block.....	71

<b>5</b>	<b>Quick Select menu.....</b>	<b>73</b>
5.1	Quick Select menu overview .....	73
5.2	Entering main menu.....	73
5.3	Logout.....	73
5.4	Performing routine test .....	74
5.5	Calling up routine test log file .....	75
5.6	Calling up alibi log file.....	76
5.7	Calling up calibration log file.....	77
<b>6</b>	<b>Event and error messages.....</b>	<b>78</b>
6.1	Error conditions .....	78
6.2	Errors and warnings.....	79
6.3	Smart weighing counter / spanner icon .....	81
<b>7</b>	<b>Technical data and accessories.....</b>	<b>82</b>
7.1	Technical data weighing terminal .....	82
7.2	Technical data weighing platforms .....	85
7.3	Accessories.....	89
<b>8</b>	<b>Appendix .....</b>	<b>92</b>
8.1	Tests for utilisation in hygienically sensitive areas .....	92
8.2	Notice for verified instruments in EC countries.....	92
8.3	Tables of Geo Code values.....	93
8.4	Disposal .....	94
8.5	Protocol printouts .....	95
8.6	Index.....	96

# 1 Introduction

## 1.1 Safety instructions



### General

- ▲ Do not use the device in a hazardous environment. Special devices are available in our range of products for hazardous environments.
- ▲ The safety of the device cannot be ensured if it is not operated in accordance with these operating instructions.
- ▲ Only authorised personnel may open the device.



### Devices with built-in power supply unit

- ▲ Ensure that the power socket outlet for the device is earthed and easily accessible, so that it can be de-energised rapidly in emergencies.
- ▲ Ensure that the supply voltage at the installation site lies within the range of 100 V to 240 V.
- ▲ Check the power cable regularly for damage. If it is damaged, immediately disconnect the device from the power supply.
- ▲ Ensure that there is a space of at least 3 cm (1.25") at the rear in order to prevent the power cable from being bent too strongly.



### Devices with built-in storage battery

- ▲ Do not use the battery charger in humid or dusty rooms or below 0 °C (32 °F) ambient temperature.
- ▲ After the built-in storage battery has been charged, the cover cap of the charging socket at the device must be closed.



### Terminal and platform combinations

- ▲ The maximum static safe load must never be exceeded. Observe the operation limits, see Technical data.
- ▲ Avoid falling loads, shock loads as well as impacts from the side.

## 1.2

## Presentation

### 1.2.1

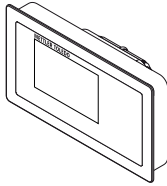

### Weighing terminals

There are two versions of the ICS649-check weighing terminal:

**ICS649a-check** with analog scale interface:

to connect analog METTLER TOLEDO weighing platforms

**ICS649d-check** with digital scale interface:

to connect METTLER TOLEDO weighing platforms with IDNet interface

On the rear the weighing terminal is equipped with a swivel bracket for mounting the terminal on the wall or to a METTLER TOLEDO column. As an accessory a table stand for setting up the terminal on the table is available.

### 1.2.2

### Terminal and platform combinations

The complete name of a terminal and platform combination also indicates the type, size and capacity of the connected analog weighing platform. E.g., ICS649a-check-A/6/c stands for

ICS649a-check	type of weighing terminal and type of weighing interface
A	design and size of the weighing platform
6	weighing platform capacity in kg
c	mechanical design

As default the weighing platforms are equipped with a hermetically sealed stainless steel load cell and a readability setting of 2 x 3000 or 5000 divisions, non-approved.

### ICS649a-check-.../f

The weighing terminal is fixed mounted in front of the weighing platform.

Terminal and platform can be handled as one unit, easy to install and to change location.

The perfect solution if a stand or a bracket would hinder an effective working process.

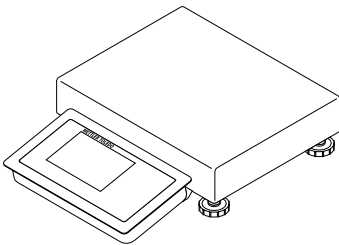

### ICS649a-check-.../t

Weighing terminal and weighing platform are connected by cable.

Suitable for wall mount operation and desk operation with an additional desk mounting plate, see Options. The combination can be upgraded with a stand, see Accessories.

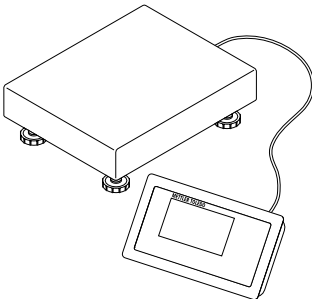

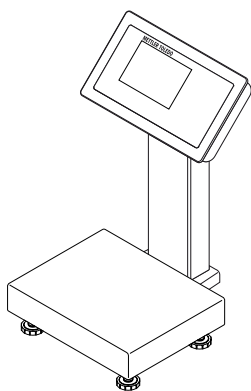

### ICS649a-check-.../c

Hygienic optimal version. Weighing terminal and column are seamlessly welded together. Easy to clean, cables run inside the column.

## 1.2.3

### Options

The following options are available for the ICS649-check:

	ICS649a-check, ICS649d-check, ICS649a-check-.../f, ICS649a-check-.../t	ICS649a-check-.../c
<b>Built-in storage battery</b>	✓	✓
<b>Optional scale interface (SCALE 2)</b>	<ul style="list-style-type: none"> <li>• analog</li> <li>• digital</li> </ul>	–
<b>Optional communication interface (COM 2)</b>	<ul style="list-style-type: none"> <li>• RS232</li> <li>• RS422/RS485</li> <li>• Ethernet</li> <li>• WLAN</li> </ul>	<ul style="list-style-type: none"> <li>• RS232</li> <li>• RS422/RS485</li> <li>• Ethernet</li> <li>• WLAN</li> <li>• USB</li> <li>• Digital I/O</li> </ul>
<b>Optional communication interface (COM 3)</b>	<ul style="list-style-type: none"> <li>• RS232</li> <li>• RS422/RS485</li> <li>• USB</li> <li>• Digital I/O</li> </ul>	–
<b>Desk mounting plate</b>	✓	–

**Terminal and platform combinations**

- Load cells for more challenging environments
  - Standard: hermetically sealed stainless steel load cell (identical to PBA430)
  - Option: loadcell with KS+ coating (identical to PBA430 with option loadcell with KS+ coating)
- Other resolutions (availability depending on region, weighing unit and Weights and Measures approval)
  - Verification OIML Class III, 1 x 3,000 e
  - Verification OIML Class III, 2 x 3,000 e MR
  - 6,000 d (non-approvable)
  - 10,000 d (non-approvable)
  - 15,000 d (non-approvable)
  - 30,000 d (non-approvable)



## 1.2.4

### Display

If you specify a target weight for Over/Under Checkweighing, the display automatically switches from the straight weighing display to the Over/Under Checkweighing display. To meet your special requirements three different display layouts are selectable in the terminal menu.

#### Straight weighing display

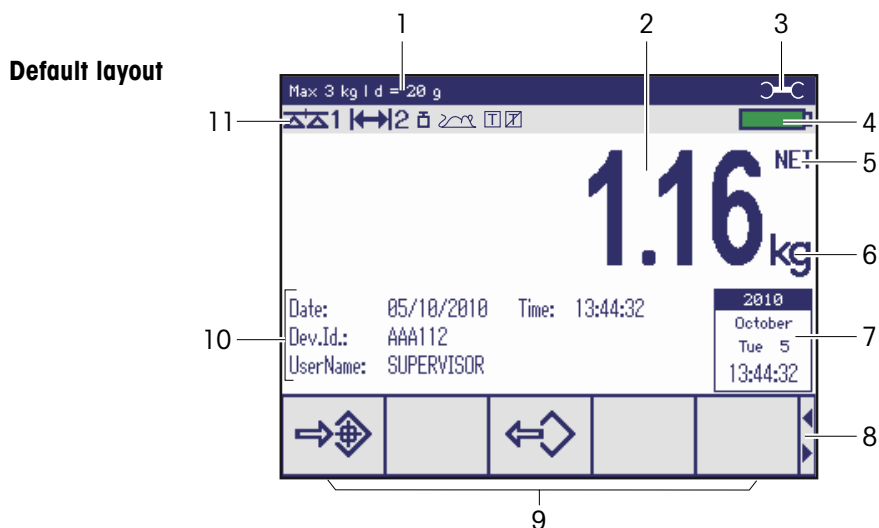

- 1 Metrological data – for details see below
- 2 Weight value with star, sign and stability monitor – for details see below
- 3 Spanner icon: service needed – for details see Event and error messages
- 4 Battery symbol
- 5 Net/Gross
- 6 Unit
- 7 Calendar – can be activated in the menu
- 8 Navigation hint: use cursor keys <, > for scrolling soft key pages
- 9 Soft keys (factory setting, page 1)
- 10 Auxiliary data – 3 lines can be defined in the menu
- 11 Symbol and info line – for details see below

#### Weight values in 3-line mode

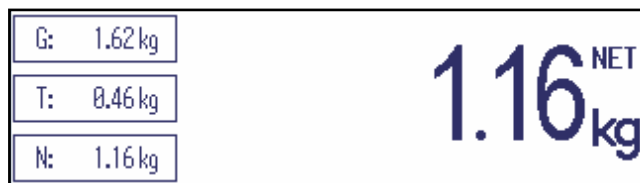

**Over/Under Checkweighing display**

In Over/Under Checkweighing the display uses colours to indicate the Over/Under Checkweighing status.

**Default layout**

Instead of the weight display a bargraph is displayed indicating target values. The example shows the default colour for a sample below the lower tolerance.

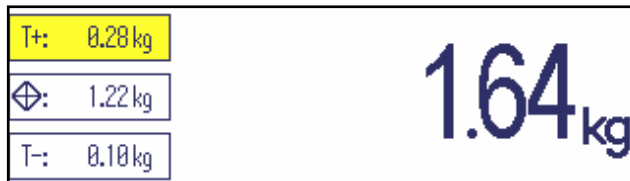
**3-line mode**

Tolerances and target weight are displayed in 3 lines.

The example shows the default colour for a sample above the upper tolerance.

**Colour mode**

The example shows the default colour for a good sample.

### Metrological data line

In the metrological data line the following information is displayed:

Symbol	Information	Remark
	Accuracy classes	Displayed only if the scale is approved according to the Weights and Measures guidelines
<b>W1</b> , <b>W2</b> , <b>W3</b>	Weighing range information	For multi range devices only, displayed only if the scale is approved according to the Weights and Measures guidelines
<b>Max</b> , <b>cap</b>	Maximum capacity	
<b>Min</b>	Minimum capacity	Displayed only if the scale is approved according to the OIML Weights and Measures guidelines
<b>e =</b>	Approved resolution	OIML: Displayed only if the scale is approved NTEP: Displayed only if the scale is approved and d is different from e
<b>d =</b>	Display resolution	OIML: Displayed only if the scale is not approved or if d is different from e NTEP: Displayed always
<b>Approved scale</b>	Approved weighing device	Metrology display disabled, Weights and Measures data must be indicated on a label near the weight display





### Weight value

The weight value can be marked with the following symbols:

Symbol	Information	Remark
*	Calculated weight value	E.g., for average weighing results
–	Sign	For negative weight values
○	Stability monitor	For unstable weight values
<b>1.2343 kg</b>	Non-approved last digit with $e > d$	For approved scales only The example shows the weight value for a scale with $e = 1 \text{ g}$ and $d = 0.1 \text{ g}$ The last, smaller digit is not approved

**Symbols and info line**

In the symbols and info line the following information can be displayed:

Symbol	Information	Remark
<->  1	Weighing range	For multi range or multi interval scales only
$\Delta^+\Delta$	Scale number	
	Weight below minimum weight	MinWeigh must be activated in the menu
	Average weighing	Average must be activated in the menu
	Automatic taring	Auto Tare must be activated in the menu
	Automatic clearing of the tare weight	A-Clear Tare must be activated in the menu
	Over/Under Check-weighing to zero	To zero must be assigned to a soft key in the menu
TA	Take-away mode	Take away must be assigned to a soft key in the menu
>0<	Center of zero indication	Availability depending on local Weights and Measures regulations

## 1.2.5

### Keyboard

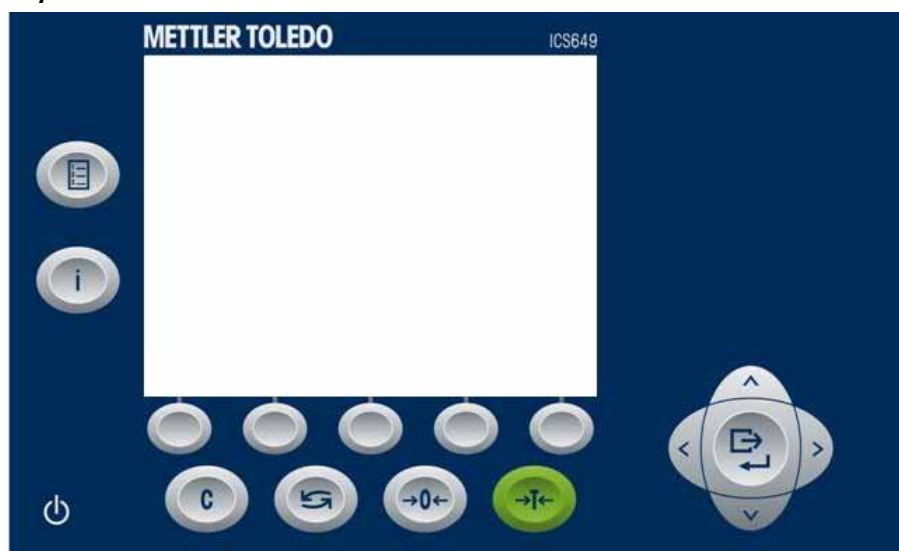





Key	Name	Function in the operating mode	Function in the menu
	Power	<ul style="list-style-type: none"> <li>Switching on and off</li> <li>Cancel editing</li> </ul>	<ul style="list-style-type: none"> <li>Cancel editing</li> <li>Exit menu</li> </ul>
	Clear	<ul style="list-style-type: none"> <li>Clear tare</li> <li>Leave info page</li> </ul>	<ul style="list-style-type: none"> <li>Clear value, clear digit</li> </ul>
	Switch	<ul style="list-style-type: none"> <li>Switch over weight unit</li> </ul>	<ul style="list-style-type: none"> <li>Re-edit</li> <li>Switch over from numerics to upper/lower case letters</li> </ul>
	Zero	<ul style="list-style-type: none"> <li>Set scale to zero, clear tare</li> </ul>	
	Tare	<ul style="list-style-type: none"> <li>Tare scale, clear tare</li> </ul>	
	Quick select	<ul style="list-style-type: none"> <li>Opening Quick Select menu, e.g., for menu access, viewing log files or logout</li> </ul>	
	Info	<ul style="list-style-type: none"> <li>Activate info screen</li> <li>Proceed to next info line / info page</li> <li>Freeze and release startup screen</li> </ul>	
	Transfer	<ul style="list-style-type: none"> <li>Transfer data to a printer or computer</li> </ul>	<ul style="list-style-type: none"> <li>Enter menu item</li> <li>Confirm entry/selection</li> </ul>
	Cursor keys	<ul style="list-style-type: none"> <li>Navigating</li> <li>Alphanumeric entry</li> </ul>	<ul style="list-style-type: none"> <li>Navigating</li> <li>Alphanumeric entry</li> </ul>

## 1.2.6

**Soft keys**

To meet your specific application requirements, ICS649-check offers 15 soft keys which can be configured in the terminal menu. The soft keys are divided into three lines (pages).

**Default setting**

<b>Page 1</b>					
	Set target		Load target		
<b>Page 2</b>			<b>ID1</b>		
	Store target		Identification 1		
<b>Page 3</b>					
	Reference n		Average piece weight		







**Operating soft keys**

→ Press the key below the desired function.

**Changing soft key line**

→ Press the cursor keys < or > to switch from line to line.

**Possible soft key settings**



Symbol	Menu setting	Function
	Target	Enter Over/Under Checkweighing parameters
	Recall	Recall Over/Under Checkweighing parameters out of the database
	Store	Store Over/Under Checkweighing parameters in the database
<b>TA</b>	Take away	Activate/Deactivate Take-away mode
	To zero	Over/Under Checkweighing to zero
<b>ID1, ID2, ID3</b>	ID1, ID2, ID3	Enter identification 1, identification 2, identification 3
	Reference n	Determine the average piece weight
	Average PW	Enter the average piece weight
	Switch scale	Switch over weighing platform

## 1.2.7

### Alphanumeric input

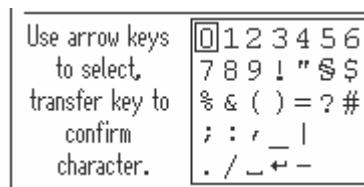
When an alphanumeric input is requested, the following is displayed:



1. Use the arrow keys <, >, ^, v to select the desired number.
2. Use  to confirm the character and move to the next place.
3. Repeat steps 1 and 2 for further characters.
4. To finish input select  of the displayed keyboard and confirm with .



Using  you can switch the displayed keyboard from upper case to lower case letters and numerics, if applicable.

## 1.2.8

### Connections

#### Weighing terminal only, ICS649a-check-.../f, ICS649a-check-.../f

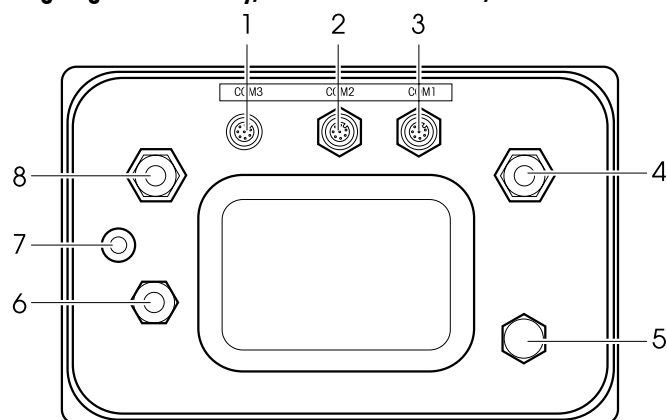

- 1 Optional interface COM3
- 2 Optional interface COM2
- 3 Standard interface COM1 (RS232)
- 4 Weighing platform connection SCALE 1
- 5 Pressure compensation
- 6 AC power supply or battery charging
- 7 Verification securing seal
- 8 Optional weighing platform connection SCALE 2

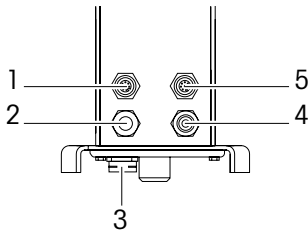

### ICS649a-check-.../c

- 1 Optional interface COM2
- 2 Weighing platform connection
- 3 Pressure compensation
- 4 AC power supply or battery charging
- 5 Standard interface COM1 (RS232)

#### Note

The verification securing seal is applied on the weighing terminal as described in the section above.

## 1.3 Tracing and tracking features

ICS649-check offers some advanced features for tracking and tracing operation on your weighing terminal:

- User management
- Alibi log file
- Routine test and routine test log file
- Calibration weight management

### 1.3.1 User management

The user management of the ICS649-check allows you to manage up to 20 users by

- user name
- user profile (operator or supervisor)
- user password
- user language
- user ID

When user management is activated, any access to the terminal is protected by password. To enter the menu a password is no longer necessary.



- User management can be configured in the menu under `Terminal -> User Management`.
- Login/logout with user management is described in chapter 2.



### 1.3.2

#### **Alibi log file**

If requested by national regulations, you can activate an alibi log file to trace all weighing activities on the scale.

The alibi log file stores all weighings with the mandatory data. In addition you can store up to 4 more items such as identifications, serial numbers and user name.



- The alibi log file can be configured in the menu under *Application* -> *Log files*.
- Viewing/printing/transferring of the alibi log file is described in the Quick Select menu.

### 1.3.3

#### **Routine test and routine test log file**

For optimum weighing results the device supports routine calibration tests.

You can configure routine tests by

- Interval (days)
- External test (for analog scales)
- Internal test (for scales with internal calibration weight)

For the external test for analog scales you can specify the following:

- Test weight (value)
- Weight name (to make sure you always use the same weight)
- Tolerance



- The routine test can be configured in the menu under *Application*-> *Log files*.
- Performing the routine test and viewing/printing/transferring of the routine test log file is described in the Quick Select menu.

### 1.3.4

#### **Calibration weight management**

For verified scales the calibration results are stored in the calibration log.



Viewing/printing/transferring of the calibration log file is described in the Quick Select menu.

## 1.4

## Commissioning

### 1.4.1

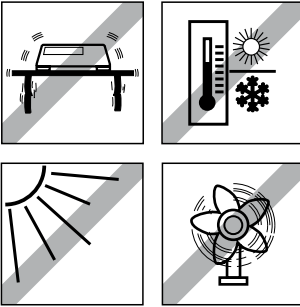

#### Selecting the weighing platform location

The correct location is crucial to the accuracy of the weighing results.

- Select a stable, vibration-free and, if possible, a horizontal location for the weighing platform.  
The ground must be able to safely bear the weight of the fully loaded weighing platform.
- Observe the following environmental conditions:
  - No direct sunlight
  - No strong drafts
  - No excessive temperature fluctuations

### 1.4.2

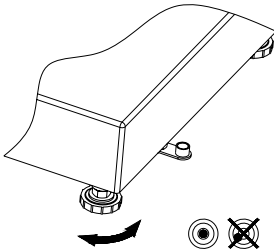

#### Levelling the weighing platform

Only weighing platforms that have been levelled precisely horizontally provide accurate weighing results. Weights and Measures approved weighing platforms have a spirit level to simplify levelling.

1. Turn the adjustable feet of the weighing platform until the spirit level's air bubble is inside the inner circle.
2. Tighten the lock nuts of the adjustable feet.

### 1.4.3

#### Weighing platform connection and interface commissioning

The weighing platform connection to the weighing terminal as well as the commissioning of the interfaces are described in the ICS4x9 installation instructions.

- Call the METTLER TOLEDO service technician or carry out commissioning in accordance with the installation instructions.

#### 1.4.4 Power supply connection



##### **CAUTION**

##### **Risk of electric shock!**

- ▲ Before connecting the power supply, check whether the voltage value printed on the rating plate corresponds to your local system voltage.
- ▲ Do not under any circumstances connect the device if the voltage value on the rating plate deviates from the local system voltage.
- ▲ Make sure the weighing platform has reached room temperature before switching on the power supply.

→ Plug the power plug into the power socket.  
After it has been connected, the device runs a self-test. The device is ready to operate when zero appears on the display.

#### 1.4.5 Handling of the built-in storage battery



Note the following when operating a device with a built-in storage battery:

- The operating life depends on the intensity of use, the configuration and the connected scale. For details see the technical data.
- The battery symbol shows the current state of charge of the storage battery.
  - One segment corresponds with approx. 25 % capacity.
  - If the symbol flashes, the storage battery has to be charged. A message is displayed, too.
  - During charging the segments are "running" until the battery is fully charged and all segments light up continuously.
- The charging time of the storage battery amounts to approx. 6 hours.  
If work is continued during the charging process, the charging time is extended.
- The storage battery is protected against overcharging.
- The storage battery has a service life of approx. 2 years or 500 to 1,000 charging/discharging cycles.
- The storage battery is also suitable for permanent mains operation.



##### **CAUTION**

##### **Danger of soiling because the charger for the storage battery is not protected to IP69K!**

- ▲ Do not charge the device in humid or dusty rooms.
- ▲ After the storage battery has been charged, close the cover cap of the charging socket at the device.



##### **CAUTION**

##### **No success in charging the storage battery due to low temperatures!**

- ▲ Do not charge the battery if the battery temperature is below 0 °C (32 °F). Charging is not possible in this temperature range.
- ▲ Do not operate the battery charger outside its temperature range of 0 °C to 40 °C (32 °F to 104 °F).

**Recommended use of the built-in storage battery**

The characteristics mentioned above are only valid if the following recommendations are observed:

- Connect the device to the battery charger as soon as the warning message "Low battery" appears and the battery symbol starts flashing. When the message appears you still have enough time (at least 10 minutes) to complete your current task.
- Keep the battery charger connected until the charging process is completed, i.e., all segments of the battery symbol light up continuously.
- For optimum battery performance operate the device with built-in storage battery at an ambient temperature in the range of 10 °C to 30 °C (50 °F to 86 °F). This applies to discharging as well as charging the battery.
- If you plan to put the scale out of operation for a longer period, charge the battery completely.
- Even if you do not use the instrument, charge the battery at least every 3 months to avoid deep discharge.

**1.5 Use in hygienically sensitive areas**

The device is easy to clean and is designed to be used in the food industry.

**Features**

- Suitability of the materials for contact with foodstuffs
- Construction made of stainless steel
- No open threads
- No screws with recesses
- Smooth, non-porous and flat surfaces that are easy to clean
- Reduced horizontal surfaces
- Continuous welding seams

For further information please refer to the appendix.

## 2 Operation

### 2.1 Switching on and off

#### 2.1.1 Switching on/off

**Switching on** → Press .

For a few seconds the device shows a start-up screen with device name, software version, serial number of the weighing terminal and the Geo value (only if an analog weighing device is connected).



- You can freeze the start-up screen by pressing **i**.
- When you start a weighing system with an analog scale the first time, a message is displayed: "Scale not calibrated". Call the METTLER TOLEDO service technician to calibrate the scale.
- When user management is active, you are asked to select your name and enter the corresponding password.



**Switching off** → Press .

Before the display goes out, **-OFF-** appears briefly.

#### 2.1.2 Login/logout

When user management is active, a login/logout procedure is required. The login screen is displayed after switching on or logging out.

- Login**
1. Select your name using the cursor keys  $\wedge$  /  $\vee$  and confirm with .
  2. Enter your password using the displayed keyboard.  
A welcome screen and then the weight display appear.

- Logout**
1. Press  to open the Quick Select menu.
  2. Select **Logout** using the cursor keys  $\wedge$  /  $\vee$  and confirm with .
  3. Press .
- The login screen is displayed, the current user is logged out.



Always log out when leaving the terminal in order to prevent unauthorised persons from working on it.

## 2.2 Zeroing / Zero point correction

Zeroing corrects the influence of slight changes on the load plate or minor deviations from the zero point.

- Manual**
1. Unload scale.
  2. Press **→0←**.  
Zero appears in the display.

**Automatic** In case of non-verified scales, the automatic zero point correction can be deactivated in the menu or the zero range can be changed. Approved scales are set fixed to 0.5 d. As standard, the zero point of the scale is automatically corrected when the scale is unloaded.



- The zero function is only available within a limited weighing range.
- After zeroing the scale, the whole weighing range is still available.
- A successful zeroing will always delete a tare weight.

## 2.3 Simple weighing

1. Place weighing sample on the scale.
2. Wait until the stability monitor **○** goes out.
3. Read the weighing result.

## 2.4 Weighing with tare

### 2.4.1 Taring

- Place the empty container on the scale and press **→T←**.  
The zero display and the symbol **NET** appear.  
The tare weight remains stored until it is cleared.

### 2.4.2 Clearing the tare

- Press **C**.  
The symbol **NET** goes out, the gross weight appears in the display.



If the symbol  is displayed, i.e., the A-Clear Tare function is activated in the menu under Scale -> Tare, the tare weight is automatically cleared as soon as the scale is unloaded.

### 2.4.3 Automatic clearing of the tare

A tare weight is automatically cleared when the scale is unloaded.

#### Prerequisite

- ✓ The symbol  is displayed, i.e., the tare function `A-Clear Tare` is activated in the menu under `Scale -> Tare`.

### 2.4.4 Automatic taring

If you place a weight on an empty scale, the scale tares automatically and the symbol **NET** is displayed.

#### Prerequisite

- ✓ The symbol  is displayed, i.e., the tare function `Auto Tare` is activated in the menu under `Scale -> Tare`.



The weight to be tared automatically, e.g., packaging material, must be heavier than 9 display steps of the scale.

### 2.4.5 Chain tare

With this function it is possible to tare several times if, e.g., cardboard is placed between individual layers in a container.

#### Prerequisite

- ✓ The tare function `Chain tare` is activated in the menu under `Scale -> Tare`.

1. Place the first container or packaging material on the scale and press **→T←**.  
The packaging weight is automatically saved as the tare weight, the zero display and the symbol **NET** appear.
2. Weigh the weighing sample and read/print out the result.
3. Place the second container or packaging material on the scale and press **→T←** again.  
The total weight on the scale is saved as the new tare weight. The zero display appears.
4. Weigh the weighing sample in the second container and read/print the result.
5. Repeat steps 3 and 4 for other containers.

**2.4.6****Tare preset**

If you know the weight of your containers, you can enter the tare weight via barcode or SICS command. Thus you do not have to tare the empty container.

**Prerequisite**

✓ For barcode use `Tare preset` is selected as destination for external input.

1. Enter the known tare weight via barcode or SICS command.  
The weight display shows the negative tare weight and the symbol **NET** appears.
2. Place the full container on the weighing platform.  
The net weight is displayed.



The entered tare weight is valid until a new tare weight is entered or the tare weight is cleared.

**2.5****Switching scales****Prerequisites**

✓ For manual totalisation the soft key  $\Delta^+\Delta$  (Switch scale) is activated in the menu under `Terminal -> Device -> Keyboard -> Softkeys`.

- Press the soft key  $\Delta^+\Delta$  to switch from scale 1 to scale 2 or vice versa.  
The current active scale is displayed in the symbol and info line on the top of the display.

**2.6****Printing results**

If a printer or computer is connected, weighing results and other information can be printed out or transferred to a computer.

- Press  $\square\rightarrow$ .

The defined data is printed out or transferred to the computer.



The printout content can be defined in the `Templates` menu.



## 2.7 Totalising

### 2.7.1 Totalising manually

#### Prerequisites

- ✓ Application -> Totalise is activated in the menu.
- ✓ For manual totalisation the soft keys **+** (Plus) and  $\Sigma$  (Total) must be activated in the menu under Terminal -> Device -> Keyboard -> Softkeys.
- ✓ If you want to follow the totalisation on the display, activate Total net and/or n for the auxiliary lines and/or the info key (Terminal -> Device -> Display -> Auxiliary lines or Terminal -> Device -> Keyboard -> Info key).

#### Totalising

1. Weigh the first sample and press the soft key **+**.  
If activated, the total net and the number of items are displayed.
2. Unload the scale.
3. Load the next sample and press the soft key **+** again.  
If activated, the total net and the number of items are increased.
4. Unload the scale.
5. Repeat steps 3 and 4 for further items.
6. To finish totalising, press the soft key  $\Sigma$ .  
A safety prompt is displayed.
7. Press softkey **YES** to clear the total.  
– or –  
Press softkey **NO** to continue totalising.



Piece counting results and Over/Under Checkweighing results can be totalised the same way.

## 2.7.2

### Automatic totalising

#### Prerequisites

- ✓ Application -> Totalise is activated in the menu.
- ✓ Good print is activated in OverUnder Checkweighing.
  - or -
  - Auto print is activated for other weighing applications.
- ✓ For clearing the total, the soft key  $\Sigma$  (Total) must be activated in the menu under Terminal -> Device -> Keyboard -> Softkeys.
- ✓ If you want to follow the totalisation on the display, Total net and/or n must be activated for the auxiliary lines and/or the info key (Terminal -> Device -> Display -> Auxiliary lines or Terminal -> Device -> Keyboard -> Info key).

#### Totalising

1. Weigh the first sample.  
The result is printed out automatically and total net and n are updated.  
If activated, the total net and the number of items are displayed.
2. Unload the scale.
3. Load the next sample.  
If activated, the total net and the number of items are increased.  
The result is printed out automatically and total net and n are updated.
4. Unload the scale.
5. Repeat steps 3 and 4 for further items.
6. To finish totalising, press the soft key  $\Sigma$ .  
A safety prompt is displayed.
7. Press softkey **YES** to clear the total.
  - or -
  - Press softkey **NO** to continue totalising.



Piece counting results and OverUnder Checkweighing results can be totalised the same way.

## 2.8 Average (dynamic) weighing

With the average weighing function, it is possible to weigh restless weighing samples such as living animals. If this function is activated,  is displayed in the info line.

With average weighing, the scale calculates the mean value from 56 weighing operations within 4 seconds.

**With manual start** ✓ *Average* -> *Manual* is selected in the menu.

✓ Weighing sample heavier than 9 scale divisions.

1. Place the weighing sample on the scale.
2. Press  to start average weighing.
3. During average weighing, stars appear in the display, and the average result will be displayed with the symbol **\***.
4. Unload the scale to be able to start a new average weighing operation.

**With automatic start** ✓ *Average* -> *Auto* is selected in the menu.

✓ Weighing sample heavier than 9 scale divisions.

1. Place the weighing sample on the scale.  
Average weighing starts automatically.  
During average weighing, stars appear in the display, and the average result will be displayed with the symbol **\***.
2. Unload the scale to be able to perform a new average weighing operation.

## 2.9 Piece counting

### 2.9.1 Piece counting with a fixed number of reference pieces

#### Prerequisite

✓ The corresponding soft key  is activated in the terminal menu.

1. Apply the reference parts (factory setting: 10 pieces) and press .  
The number of reference pieces is displayed.
2. Load the parts to be counted.  
The number of pieces is displayed.



- The average weight remains stored until a new reference is determined.
- The number of reference parts can be set in the application menu.
- The auxiliary line and the info page can be configured to show the average piece weight.

## 2.9.2

### Piece counting with a known piece weight

#### Prerequisite

✓ The corresponding soft key  is activated in the terminal menu.

1. Press .  
Input of the average piece weight (APW) is requested.
2. Enter the average piece weight.  
The weight unit changes to PCS.
3. Load the parts to be counted.  
The number of pieces is displayed.



- The average piece weight remains stored until a new average piece weight is determined.
- You can enter the average piece weight via barcode if the external input destination is configured to "Average PW".

## 2.9.3

### Terminating piece counting

- Press **C**.  
"Cleared" appears in the display.  
The average piece weight is cleared and the weight value is displayed.  
The device operates in straight weighing mode.

## 2.10 Working with identifications

Weighing series can be assigned 3 identification numbers ID1, ID2 and ID3 with up to 40 characters that are also printed out in the protocols. If for example a customer number and an article number are assigned, it can be clearly seen in the protocol which article was weighed for which customer.

### Direct entry

✓ At least one of the soft keys **ID1**, **ID2** or **ID3** is activated.

1. Press the desired soft key **ID1**, **ID2** or **ID3**.  
The last entered ID is displayed.
2. To edit the ID press the soft key .
3. Enter the ID using the displayed alphanumeric keyboard.
4. Confirm entry with **↵** of the displayed keyboard.  
The entered ID is assigned to the following weighings until the ID is changed.

### Barcode use (for one identification only)

- ✓ ID1, ID2 or ID3 is selected as destination for external input.
- ✓ To display the identification ID1, ID2 or ID3 is activated in the auxiliary line.

### Using SICS command set (up to three identifications)

- ✓ To display the identification(s) the corresponding IDs are activated in the auxiliary line.

## 2.11 Displaying information

Up to 27 different values for display can be configured in the menu for the info key. Depending on the configuration in the menu `Terminal -> Device -> Keyboard -> Info key`, the following data can be assigned in a free order, e.g.,

- Date & Time
- Weight values
- Identifications
- Device information
- Serial numbers and software versions
- User name

1. Press **i**.  
The (first) info screen is displayed.
2. Press **i** again.  
With one info screen only, the weight display appears.  
With several info screens, the next info screen is displayed.
3. With several info screens press **C** to leave the info screens.

An info screen is displayed until **i** is pressed again or **C** is pressed.



## 2.12 Environment and cleaning

### 2.12.1

#### Overview

The devices are designed to be used in a wet environment. Depending on the environment and the cleaning procedures we suggest weighing platforms with different types of load cells. The following table gives you a detailed overview about the recommended environment and suitable cleaning procedures.

	Terminal	Weighing platform	
	ICS649a-check ICS649d-check	Standard version hermetically sealed stainless steel load cell	Option load cell with KS+ coating
IP rating	IP68/IP69k	IP68/IP69k	IP68/IP69k
<b>Environment</b>			
Short time wet (30 min / day)	✓	✓	✓
Part time wet (120 min / day)	✓	✓	✓
Permanent wet	✓	✓	✓
<b>Cleaning procedure</b>			
Wet wipe down	✓	✓	✓
Light hose down < 5 l / min, 20 kPa	✓	✓	✓
Light wash down < 12.5 l / min, 30 kPa	✓	✓	✓
Heavy wash down high pressure water and steam jet up to 10000 kPa	✓	✓	✓
<b>Cleaning detergents</b>			
Mild detergents	✓	✓	✓
Other detergents in accordance with the manufacturer's specifications and instructions	✓	✓	✓
Acids, lyes, solvents	–	–	✓

## 2.12.2



### General cleaning recommendations

#### Risk of electric shock

- ▲ Before cleaning, unplug the power plug in order to disconnect the terminal from the power supply.
- ▲ Cover open connectors with cap plugs.
  
- Clean the protective cover separately. The protective hood is dishwasher-safe.
- Replace the protective hood regularly.
- Take off the load plate and remove any dirt and foreign substances which may have collected underneath. Do not use any hard objects to do so.
- Do not disassemble the weighing device.
- Remove any possibly remaining detergent by rinsing with clear water.
- To prolong the lifetime of the load cell, dry it with a soft lint-free cloth immediately after cleaning.
- Observe all the existing regulations on cleaning intervals and permissible cleaning agents.

#### Cleaning of different weighing platforms as described in this User manual

- Make sure to observe the cleaning instructions for the connected weighing platform. The weighing platform may not be designed for wet environments and the cleaning procedures described above.

## 2.13

### Verification test

The weighing instrument is verified if

- the accuracy class is displayed in the metrological line,
- the securing seal is not tampered with,
- it bears an official verification mark, e.g., the green M sticker (OIML),
- the validity is not expired.

The weighing instrument is also verified if

- the metrological line shows "Approved scale",
- labels with the metrological data are placed near the weight display,
- the securing seal is not tampered with,
- it bears an official verification mark, e.g., the green M sticker (OIML),
- the validity is not expired.



The period of validity is country-specific. It is in the responsibility of the owner to renew verification in due time.

### Terminal and platform combinations

Combinations of a weighing terminal and an analog weighing platform use a Geo Code to compensate for gravitational influence.

The manufacturer of the weighing instrument uses a defined Geo Code value for verification.

- ➔ Please check if the Geo Code in the instrument corresponds with the Geo Code value defined for your location.

The Geo Code value is displayed when you switch on the instrument.

The Geo Code for your location is shown in the Appendix.

- ➔ Call the METTLER TOLEDO service technician if the Geo Code values do not match.



## 3 Over/Under Checkweighing

The device offers Over/Under Checkweighing functions. The respective settings in the menu are described in the application menu section.

The corresponding coloured background lighting allows rapid detection of the states "too light" (factory setting: red), "good" (factory setting: green) and "too heavy" (factory setting: yellow). The colours can be modified in the menu.

### **Prerequisite**

✓ The soft keys for Over/Under Checkweighing are activated in the terminal menu section.

### 3.1 Specifying target values

Different entries are required at the beginning of Over/Under Checkweighing or Over/Under Checkcounting, depending on the tolerance type setting.

#### **Tolerance type "Absolute"**

A low and a high weight value must be entered. These weights and all weights within this range are treated as being within tolerance.

#### **Tolerance type "Relative"**

Target weight (Target) as well as lower tolerance (Tol-) and upper tolerance (Tol+) have to be specified. The tolerances are displayed as relative deviations from the target weight.



#### **Tolerance type "Percent"**

Target weight (Target) as well as lower tolerance (Tol-) and upper tolerance (Tol+) have to be specified. At Over/Under Checkweighing the weight value is represented as a percentage of the target weight. The target weight 100 % is striven for, or 0 % at Over/Under Checkweighing to zero.

### 3.1.1

#### Weighing in target values

The following section describes the course of the factory setting for the Over/Under Checkweighing application.

1. Press .  
The current Over/Under Checkweighing parameters are displayed.
2. Check tolerance type. Use soft key  to change the tolerance type and soft key **OK** to proceed to the first weight.  
With a tolerance type selected in the menu, this step does not appear.
3. Load requested weight and press soft key **OK**.  
The next parameter is highlighted.
4. Repeat step 3 until "New target set!" is displayed.  
The coloured Over/Under Checkweighing display appears, the scale is ready for Over/Under Checkweighing.







- If tolerance default values have been set in the menu, only the target has to be specified with tolerance types "Relative" and "Percent".
- The upper tolerance value has to be greater than or equal to the lower one ( $\text{High} \geq \text{Low}$ ) or, respectively, the target weight has to be greater than or equal to the lower tolerance value and smaller than or equal the upper tolerance ( $\text{Tol+} \geq \text{Target} \geq \text{Tol-}$ ).

### 3.1.2

#### Entering known target values

The following section describes the course of the factory setting for the Over/Under Checkweighing application.



1. Press .  
The current Over/Under Checkweighing parameters are displayed.
2. Check tolerance type. Use soft key  to change the tolerance type and soft key **OK** to proceed to the first weight.  
With a tolerance type selected in the menu, this step does not appear.
3. Enter the requested weight value.  
Use soft key  to open entry.
4. Confirm entry with  of the displayed keypad.  
The next parameter is highlighted.
5. Repeat steps 3 and 4 until "New target set!" is displayed.  
The coloured checkweighing display appears, the scale is ready for checkweighing.



- If tolerance values have been set in the menu, only the target has to be specified with tolerance types "Relative" and "Percent".
- The upper tolerance value has to be greater than the lower one ( $\text{High} > \text{Low}$ ) or, respectively, the target weight has to be greater than the lower tolerance value ( $\text{Tol+} > \text{Target} > \text{Tol-}$ ).

### 3.1.3 Specifying target number of pieces

#### Prerequisite

✓ At least one of the counting soft keys  or  is activated.

#### Determining the piece weight

→ Apply the reference parts (factory setting: 10 pieces) and press .  
The number of reference pieces is displayed.



- For alternate procedures to determine the piece weight refer to the counting section.
- If you use the unit PCS, the tolerance type Percent ist not available.

#### Weighing in the target number of pieces

→ Proceed as described in section "Weighing in target values".  
The display unit is PCS.

### 3.1.4 Using stored target values

#### Storing target records

A target record contains the following: Tolerance type, target weight and tolerances. If available, tare weight, average piece weight and description field can be stored, too.  
Up to 500 target values can be stored.

1. Enter the target values as described in the sections above.
2. Press soft key .  
The display changes to green to indicate a free record. The record number of the first free memory and status "Free" are displayed.
3. If necessary, change the desired record number.
4. Press soft key **OK**.  
"Record stored!" briefly appears in the display. The target record is stored under the selected number.



If the selected record is already occupied, the background lighting changes to red and "Occupied" is displayed.





1. In order to overwrite the record with the new values, press soft key **OK**.  
The message "Overwrite record?" appears.
2. Press soft key **YES** to overwrite the record or soft key **NO** to cancel.

### Loading the target records

1. Press soft key .  
The first occupied record is shown.
2. Select the desired record number.
3. Press soft key **OK**.  
"Record loaded!" briefly appears in the display. The Over/Under Checkweighing display appears, the scale is ready for Over/Under Checkweighing.

### Searching for target records

Using the soft key  you can search for target records by record number, article name and article number or item – if specified in the target set.

1. Press soft key .  
The first occupied record is shown.
2. Press soft key .  
"Search by ..." is displayed.
3. Using soft key  you can select the search criterion, i.e., record no., article no., article name and item.
4. Confirm search criterion with .
5. Enter record data to be searched for.  
If existent, the searched record is displayed.
6. Press soft key  to load the target record.

## 3.2

### Over/Under Checkweighing procedure

The device facilitates Over/Under Checkweighing and Over/Under Checkcounting through different coloured background lighting for the states "too light" (factory setting: red), "good" (factory setting: green) and "too heavy" (factory setting: yellow).

1. Specify the target values as described above.
2. Place the checkweighing material on the scale.  
Depending on the applied weight the colour of the background lighting changes.  
Weight information is displayed in accordance with the display setting and the Over/Under Checkweighing settings.

### Display for Over/Under Checkweighing and tolerance type "Absolute"

With default settings for display type and colours, the following is displayed for "too light", "good", "too heavy":

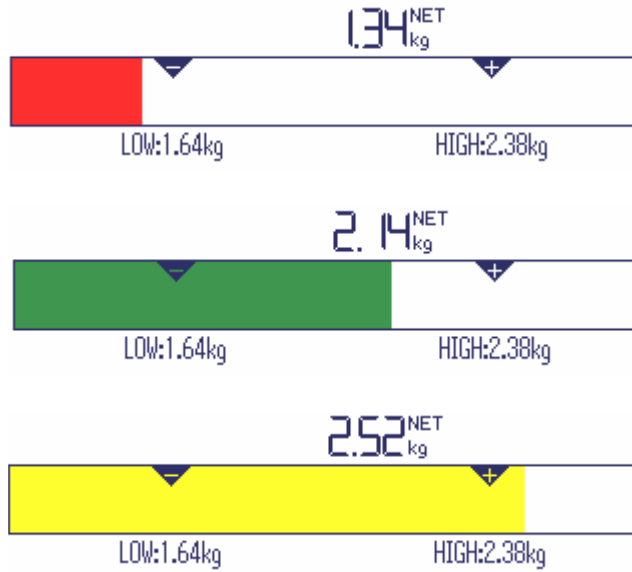

### Display for Over/Under Checkweighing and tolerance type "Relative"

With default settings for display type and colours, the following is displayed for "too light", "good", "too heavy":

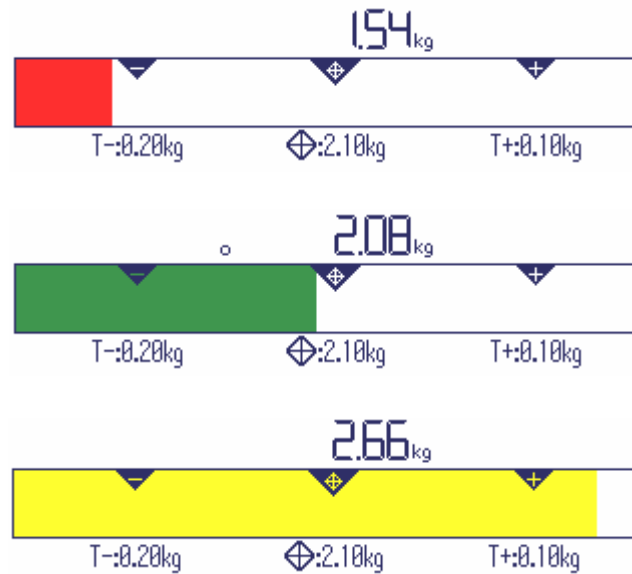

**Display for Over/Under Checkweighing and tolerance type "Percent"**

With default settings for display type and colours, the following is displayed for "too light", "good", "too heavy":

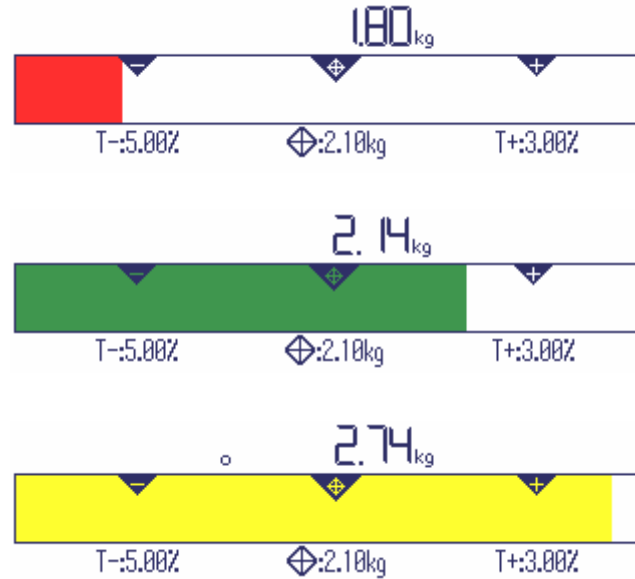
**3.3****Over/Under Checkweighing during subtractive weighing**

Assistance through the coloured background and the graphical weighing aid is also possible during subtractive weighing and subtractive counting.

**Procedure**

1. Specify target values as described above.  
The target value is indicated with a negative sign.
2. Place a full container on the weighing platform and tare it.
3. Remove as much from the weighing sample as required for the display to change to the state "good" (factory setting = green).
4. Tare the unit again.  
The scale is ready for the next removal.

### Display for subtractive Over/Under Checkweighing

With default settings for display type and colours the following is displayed for "too light", "good", "too heavy":

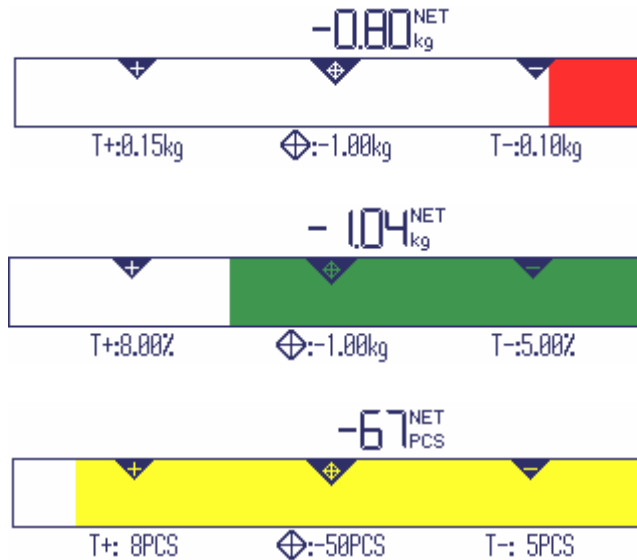

## 3.4 Over/Under Checkweighing with "Quick start"

If default values for the tolerances are used with tolerance types "Relative" or "Percent", Over/Under Checkweighing can be started by pressing just one key.

### Prerequisites

- ✓ The setting `On` is selected in the menu under `Application -> Over/under -> Default Values -> Activate`.
- ✓ Tolerance values are defined under `Application -> Over/under -> Default Values -> Relative weight/Percent weight/Relative pieces`.
- ✓ The selected tolerance type matches the entered default values.

### Procedure

- ➔ Place the target weight or target amount on the scale and press soft key  $\rightarrow$   $\oplus$ .  
The applied weight or the applied amount is stored as the target weight or target amount respectively. The display changes to the state "good" (factory setting = green). Over/Under Checkweighing is activated.

### 3.5

#### Over/Under Checkweighing in Take-away mode

In this mode the same items can be weighed into a container or weighed out of a container without a key having to be pressed between the actions.

##### Prerequisite

- ✓ The soft key **TA** is activated.

##### Procedure

1. Specify target values as described above.  
For subtractive weighing, the target value has to be negative.
  2. For weighing in, place the empty container on the scale,  
for weighing out of the container place the full container on the scale.
  3. Press soft key **TA**.  
"Take away active" is displayed briefly. The symbol "TA" appears in the info line and the container is tared.
  4. When weighing in, place the checkweighing material into the container.  
When weighing out (negative target value), remove weighing material from the container.
  5. If the applied/removed weight or the applied/removed amount lies within the tolerance values, taring is carried out automatically.  
The next item can be weighed in/removed.
- 
- To use an item that is too light or too heavy, taring must be carried out manually.
  - To leave Take-away mode, press soft key **TA** again. The symbol "TA" disappears.
  - You can select the "Good print" feature to generate an automatic printout when the weight is within tolerance.
  - You can select "Auto tare" and "Auto clear tare" to continue working after the full or empty container needs to be replaced without touching one key.





## 3.6 Over/Under Checkweighing to zero

The weight value or the number of pieces can also be represented as the difference to the target weight.

### Prerequisites

- ✓ For Over/Under Checkweighing to zero, tolerance types "Relative" or "Percent" are selected  
For Over/Under Checkcounting to zero, tolerance type "Relative" is selected
- ✓ The soft key ↓0 (to zero) is activated
- ✓ Display layout "Colour mode" or "3-line mode" selected

### Procedure

1. Specify the target values as described above.
2. Press the soft key ↓0.  
The target is displayed with a minus sign.
3. Place the checkweighing material on the scale.  
Depending on the applied weight or the applied amount the colour of the background lighting changes.  
The display value is displayed in accordance with the tolerance type setting.  
The target value is 0 (kg or PCS) or 0.00 %.

### Terminating Over/Under Checkweighing to zero

- Press soft key ↓0 again.  
The symbol ↓0 in the info line disappears, the net weight is displayed.

**Display at Over/Under Checkweighing to zero**

With display type "Colour mode" and default colours the following is displayed for "too light", "good", "too heavy":

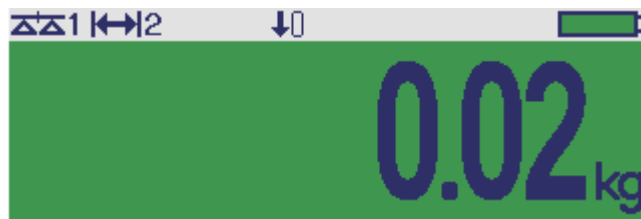
**3.7****Terminating Over/Under Checkweighing**

→ Press **C**.

"Cleared" appears in the display.

The target values are cleared and the straight weighing display appears.

The device operates in straight weighing mode.

## 4 Settings in the menu

In the menu, settings can be changed and functions can be activated. This enables adaptation to individual weighing requirements.



The menu consists of the following 5 main blocks containing various submenus on several levels.



Scale	see section 4.2 (analog scales) or 4.3 (IDNet scales)
Application	see section 4.4
Terminal	see section 4.5
Communication	see section 4.6
Maintenance	see section 4.7

### 4.1 Operating the menu

#### 4.1.1 Calling up the menu and entering the password

The menu differentiates between 2 operating levels: Operator and Supervisor. The Supervisor level can be protected by a password. When the device is delivered, both levels are accessible without a password.

- Operator menu**
1. Press .  
The Quick Select menu opens, `Menu` is highlighted.
  2. Press .  
`Enter code` is displayed.
  3. Press  again.  
The menu item `Terminal` is displayed. Only parts of the submenu `Device` are accessible.



- Supervisor menu**
1. Press .  
The Quick Select menu opens, `Menu` is highlighted.
  2. Press .  
`Enter code` is displayed.
  3. Enter the password.  
The first menu item `Scale` is highlighted.



- When the device is first delivered, the supervisor password is set to 423. Set your individual password in the `Terminal` menu.
- If a password has still not been entered after a few seconds, the scale returns to the weighing mode.
- If a password has been issued for Supervisor access to the menu and you have forgotten it, please contact the METTLER TOLEDO service.

### Calling up menu when user management is active

If user management is active, password entry is required when logging in.

1. Press .  
The Quick Select menu opens, `Menu` is highlighted.
2. Press .  
The menu start screen is displayed, depending on the user profile.

#### 4.1.2

### Display presentation in the menu

Menu items are displayed together with their context. The following example shows the menu start screen.

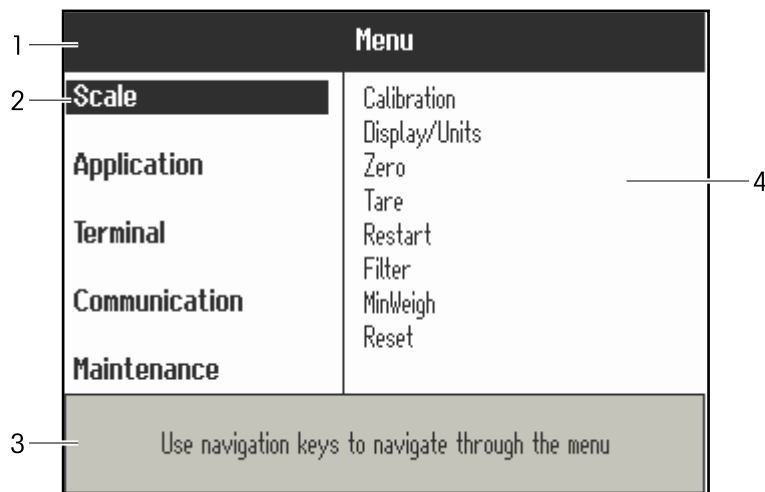

- 1 Menu info line, i.e., menu path of the current menu item
- 2 Menu items; the selected menu item is highlighted
- 3 Navigation info line
- 4 Sub-menu items

#### 4.1.3

### Exiting the menu

1. Press .  
The last menu item `End` appears. "Save settings ?" is displayed.
2. Press **OK**.  
The menu changes are saved and the terminal returns to the weighing mode.  
- or -  
→ Press **ESC** for further menu settings.  
- or -  
→ Press **NO** to discard changes and return to the weighing mode.

#### 4.1.4 Selecting and setting parameters in the menu

##### Example: Setting of the Chain tare function

Menu	
<b>Scale</b>	Calibration
	Display/Units
<b>Application</b>	Zero
	Tare
<b>Terminal</b>	Restart
	Filter
<b>Communication</b>	MinWeigh
	Reset
<b>Maintenance</b>	

1. In the menu start screen press > to switch to the right side.  
The first submenu `Calibration` is highlighted.

Scale	
<b>Calibration</b>	Auto tare
<b>Display/Units</b>	Chain tare
<b>Zero</b>	A-Clear tare
<b>Tare</b>	
<b>Restart</b>	
<b>Filter</b>	
<b>MinWeigh</b>	
<b>Reset</b>	

2. Use  $\downarrow/\uparrow$  to select `Tare`.  
The current `Tare` settings are displayed on the right side.
3. Press > to open the selected (highlighted) menu item `Tare`.  
The `Tare` submenus are displayed on the left side.

Scale – Tare	
<b>Auto tare</b>	
<b>Chain tare</b>	On
<b>A-Clear tare</b>	

4. Use  $\downarrow/\uparrow$  to select `Chain tare`.  
The current `Chain tare` setting is displayed on the right side.
5. Press > to open the selected (highlighted) menu item `Chain tare`.  
All possible `Chain tare` settings are displayed on the right side, the current setting is highlighted.
6. Use  $\downarrow/\uparrow$  to change the `Chain tare` setting.
7. Confirm the setting with  $\rightarrow$ .

## 4.2 Scale menu block – analog scales

Factory settings are printed in **bold** in the following overview.





### 4.2.1 Overview

Level 1	Level 2	Level 3
Calibration		
Display/ Units	Unit 1	g, <b>kg</b> , oz, lb, lb-oz, t
	Unit 2	<b>g</b> , kg, oz, lb, lb-oz, t
	Resolution	
	Unit roll	On, <b>Off</b>
Zero	AZM	Off, <b>0.5 d</b> , 1 d, 2 d, 5 d, 10 d
Tare	Auto tare	On, <b>Off</b>
	Chain tare	<b>On</b> , Off
	A-Clear tare	On, <b>Off</b> , 9 d
Restart	On, <b>Off</b>	
Filter	Vibration	Low, <b>Medium</b> , High
	Process	<b>Universal</b> , Dosing
	Stability	Fast, <b>Standard</b> , Precise
MinWeigh	Function	On, <b>Off</b>
Reset	Perform reset ?	

## 4.2.2 Description of the (analog) Scale menu block

### (Analog) Scale → Calibration

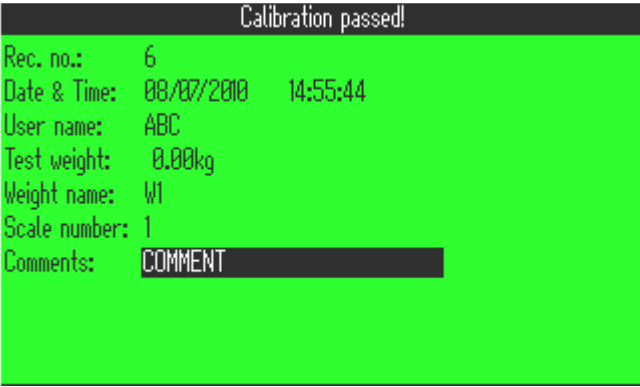
This menu item is not available for verified scales.

<p><b>Perform calibration ?</b></p>	<ol style="list-style-type: none"> <li>1. Unload scale.</li> <li>2. Start calibration with .</li> <li>The scale determines the zero point, -0- appears in the display. The calibration weight to be placed on the scale flashes in the display.</li> <li>3. If necessary, change the weight value displayed with <b>→T←</b>.</li> <li>4. Place the calibration weight on the scale and confirm with .</li> <li>The scale calibrates with the calibration weight loaded. After calibration is completed, -Done- appears briefly in the display and the calibration protocol is displayed.</li> </ol>  <ol style="list-style-type: none"> <li>5. You can now enter User name, Weight name and Comments if applicable.</li> </ol>
<p>Note</p>	<ul style="list-style-type: none"> <li>• In order to achieve particularly high precision, calibrate under full load. The calibration process can be aborted using .</li> <li>• The calibration protocol is stored in the calibration log file.</li> </ul>

### (Analog) Scale → Display/Units – Weighing unit and display accuracy

<p><b>Unit 1</b></p>	<p>Select weighing unit 1: g, kg, oz, lb, lb-oz, t</p>
<p><b>Unit 2</b></p>	<p>Select weighing unit 2: g, kg, oz, lb, lb-oz, t</p>
<p><b>Resolution</b></p>	<p>Select readability (resolution), the possible settings depend on the connected scale.</p>
<p><b>Unit roll</b></p>	<p>When unit roll is switched on, the weight value can be displayed in all available units with .</p>
<p>Notes</p>	<ul style="list-style-type: none"> <li>• In case of verified scales, individual sub-items of the <code>Display</code> menu item may not be available or only to a limited extent, depending on the respective country.</li> <li>• On dual-range/dual interval scales, resolutions marked with <b> ←→  1/2</b> are divided up into 2 weighing ranges/intervals, e.g., 2 x 3000 d.</li> </ul>

**(Analog) Scale → Zero – Automatic zero update**

<b>AZM</b>	On verified scales, this menu item does not appear. Switching on/off automatic zero update and selecting zeroing range. Possible settings: Off; <b>0.5 d</b> ; 1 d; 2 d; 5 d; 10 d
------------	--

**(Analog) Scale → Tare – Tare function**

<b>Auto tare</b>	Switching on/off automatic taring
<b>Chain tare</b>	Switching on/off chain tare
<b>A-Clear tare</b>	Switching on/off automatic clearing of the tare weight when the load is removed from the scale. <ul style="list-style-type: none"> <li>• <b>On</b> The tare weight is automatically cleared if the gross weight is 0 or below zero</li> <li>• <b>Off</b> No automatic clearing of the tare weight</li> <li>• <b>9 d</b> The tare weight is automatically cleared if the gross weight is within +/- 9 display steps</li> </ul>

**(Analog) Scale → Restart – Automatic saving of zero point and tare value**

<b>Restart</b>	When the restart function is activated, the last zero point and the tare value are saved. After switching off/on or after a power interruption, the device continues to work with the saved zero point and tare value.
----------------	--

**(Analog) Scale → Filter –  
Adaptation of the ambient conditions and the weighing type**

<b>Vibration</b> Low Medium High	Adaptation to ambient conditions <ul style="list-style-type: none"> <li>• Very steady and stable environment. The scale works very rapidly, but is very sensitive to external influences.</li> <li>• Normal environment. The scale operates at medium speed.</li> <li>• Restless environment. The scale works more slowly, but is insensitive to external influences.</li> </ul>
<b>Process</b> Universal Dosing	Adaptation to the weighing process <ul style="list-style-type: none"> <li>• Universal setting for all weighing samples and normal weighing goods.</li> <li>• Dispensing liquid or powdery weighing samples.</li> </ul>
<b>Stability</b> Fast Standard Precise	Adjusting the stability detector <ul style="list-style-type: none"> <li>• The scale operates very fast.</li> <li>• The scale operates at medium speed.</li> <li>• The scale operates with the greatest possible reproducibility.</li> </ul> <p>The slower the scale works, the greater the reproducibility of the weighing results.</p>



### (Analog) Scale → MinWeigh – Minimum weighing-in quantity

Before you can use this function, the METTLER TOLEDO service technician has to determine and to enter a minimum weight value.

<b>Function</b>	Switching minimum weight function on/off If the weight on the scale drops below the stored minimum weight,  appears in the symbols and info line.
-----------------	---

### (Analog) Scale → Reset – Resetting scale settings to factory settings

<b>Perform reset ?</b>	Confirmation inquiry <ul style="list-style-type: none"> <li>Reset the analog scale settings to factory settings with <b>YES</b>.</li> <li>Do not reset the analog scale settings with <b>NO</b>.</li> </ul>
------------------------	---

## 4.3 Scale menu block – IDNet scales

Factory settings are printed in **bold** in the following overview.

### 4.3.1 Overview

Level 1	Level 2	Level 3
Display/ Units	Unit 2	<b>g</b> , kg, oz, lb, t
	Unit roll	On, <b>Off</b>
Zero	AZM	<b>On</b> , Off
Tare	Auto tare	On, <b>Off</b>
	Chain tare	<b>On</b> , Off
	A-Clear tare	On, <b>Off</b> , 9 d
Restart	On, <b>Off</b>	
Filter	Vibration	Stable, <b>Normal</b> , Unstable
	Process	Finefill, <b>Universal</b> , Absolut
	Stability	ASD=0, ASD=1, <b>ASD=2</b> , ASD=3, ASD=4
Update	The possible settings depend on the connected scale	
MinWeigh	Function	On, <b>Off</b>
Reset	Perform reset?	

## 4.3.2

## Description of the (IDNet) Scale menu block

**(IDNet) Scale → Display – Weighing unit**

<b>Unit 2</b>	Select weighing unit 2: g, kg, oz, lb, t
<b>Unit roll</b>	When unit roll is switched on, the weight value can be displayed in all available units with  .
Notes	<ul style="list-style-type: none"> <li>• In case of verified scales, individual sub-items of the Display menu item may not be available or only to a limited extent, depending on the respective country.</li> <li>• On multi-range/multi-interval scales, the symbol <b>I&lt;-&gt;I</b> with number indicates the current range or interval.</li> </ul>

**(IDNet) Scale → Zero – Automatic zero update**

<b>AZM</b>	<p>On verified scales, this menu item does not appear.</p> <p>Switching on/off automatic zero update</p> <p>The effective range of the zero update mode (<b>0.5 d</b>; 1 d; 2 d; 3 d) can only be set by service technician.</p>
------------	--

**(IDNet) Scale → Tare – Tare function**

<b>Auto tare</b>	Switching on/off automatic taring
<b>Chain tare</b>	Switching on/off chain tare
<b>A-Clear tare</b>	<p>Switching on/off automatic clearing of the tare weight when the load is removed from the scale.</p> <ul style="list-style-type: none"> <li>• <b>On</b> The tare weight is automatically cleared if the gross weight is 0 or below zero</li> <li>• <b>Off</b> No automatic clearing of the tare weight</li> <li>• <b>9 d</b> The tare weight is automatically cleared if the gross weight is within +/- 9 display steps</li> </ul>

**(IDNet) Scale → Restart – Automatic saving of zero point and tare value**

<b>Restart</b>	<p>When the Restart function is activated, the last zero point and the tare value are saved.</p> <p>After switching off/on or after a power interruption, the device continues to work with the saved zero point and tare value.</p>
----------------	--

**(IDNet) Scale -> Filter –**

**Adaptation to the ambient conditions and the weighing type**

<p><b>Vibration</b></p> <p>Stable</p> <p>Normal</p> <p>Unstable</p>	<p>Adaptation to the ambient conditions</p> <ul style="list-style-type: none"> <li>• Very steady and stable environment. The scale works very rapidly, but is very sensitive to external influences.</li> <li>• Normal environment. The scale operates at medium speed.</li> <li>• Restless environment. The scale works more slowly, but is insensitive to external influences.</li> </ul>																		
<p><b>Process</b></p> <p>Finefill</p> <p>Universal</p> <p>Absolut</p>	<p>Adaptation to the weighing process</p> <ul style="list-style-type: none"> <li>• Dispensing of liquid or powdered weighing samples.</li> <li>• Universal setting for all weighing modes and normal weighing goods.</li> <li>• For solid bodies under extreme conditions, e.g., strong vibrations.</li> </ul>																		
<p><b>Stability</b></p> <p>ASD = 0 ... ASD = 4</p>	<p>Adjusting stability monitoring</p> <table border="0"> <tr> <td>ASD = 0</td> <td>Stability monitoring switched off</td> <td></td> </tr> <tr> <td></td> <td>Only possible for non-verified scales</td> <td></td> </tr> <tr> <td>ASD = 1</td> <td>Rapid display</td> <td>Good reproducibility</td> </tr> <tr> <td><b>ASD = 2</b></td> <td>↑</td> <td>↓</td> </tr> <tr> <td>ASD = 3</td> <td>↑</td> <td>↓</td> </tr> <tr> <td>ASD = 4</td> <td>Slow display</td> <td>Excellent reproducibility</td> </tr> </table>	ASD = 0	Stability monitoring switched off			Only possible for non-verified scales		ASD = 1	Rapid display	Good reproducibility	<b>ASD = 2</b>	↑	↓	ASD = 3	↑	↓	ASD = 4	Slow display	Excellent reproducibility
ASD = 0	Stability monitoring switched off																		
	Only possible for non-verified scales																		
ASD = 1	Rapid display	Good reproducibility																	
<b>ASD = 2</b>	↑	↓																	
ASD = 3	↑	↓																	
ASD = 4	Slow display	Excellent reproducibility																	

**(IDNet) Scale -> Update – Setting the display speed of the weight display**

This menu item is only displayed if the UPDATE function is supported by the connected scale.

<p><b>xx UPS</b></p>	<p>Selecting the number of updates per second (UPS)</p>
<p>Note</p>	<p>The possible settings depend on the connected scale</p>

**(IDNet) Scale -> MinWeigh – Minimum weighing-in quantity**

Before you can use this function, the METTLER TOLEDO service technician has to determine and enter a minimum weight value.

<p><b>Function</b></p>	<p>Switching minimum weight function on/off</p> <p>If the weight on the scale drops below the stored minimum weight,  appears in the symbols and info line.</p>
------------------------	--

**(IDNet) Scale -> Reset – Resetting scale settings to factory settings**

<p><b>Perform reset ?</b></p>	<p>Confirmation inquiry</p> <ul style="list-style-type: none"> <li>• Reset the IDNet scale settings to factory settings with <b>YES</b>.</li> <li>• Do not reset the IDNet scale settings with <b>NO</b>.</li> </ul>
-------------------------------	--

## 4.4 Application menu block

Factory settings are printed in **bold** in the following overview.

### 4.4.1 Overview

Level 1	Level 2	Level 3	Level 4
Average	<b>Off</b> , Auto, Manual		
Over/Under	Tolerance type	<b>Off</b> , Absolute, Relative, Percent	
	Default values	Activate	<b>Off</b> , On
		Relative weight	Tolerance -, Tolerance +
		Percent weight	Tolerance -, Tolerance +
		Relative pieces	Tolerance -, Tolerance +
	Output	Setpoint tol-	
Good print		<b>Off</b> , On	
Data storage	Descr. field	Activate	<b>Off</b> , On
	Article name	Activate	<b>Off</b> , On
	Article number	Activate	<b>Off</b> , On
	Delete all	Sure?	
	Delete record		
Count	Reference n		
Log files	Alibi Log	Activate	
		Item 7 ... Item 10	ID1, ID2, ID3, Dev. identifier, Dev. location, SNR Terminal, SNR Scale 1, SNR Scale 2, User name
		Delete all records	
	Routine Test Log	Days	
		External test	Test weight, Weight name, Tolerance
		Internal test	
		Delete all records	
Totalize	Activate	<b>Off</b> , On	
Reset	Perform reset ?		

#### 4.4.2

#### Description

##### Application → Average –

##### Determining the average weight for an unstable load (dynamic weighing)

<b>Off</b>	Calculating average weight switched off
<b>Auto</b>	Calculating average weight with automatic start of the weighing cycle
<b>Manual</b>	Calculating average weight with manual start of the weighing cycle via 

##### Application → Over/Under – Setting Over/Under Checkweighing parameters

<p><b>Tolerance type</b></p> <p>Off</p> <p>Absolute</p> <p>Relative</p> <p>Percent</p>	<p>Specify which parameters have to be entered for Over/Under Checkweighing.</p> <p>No tolerance type predefined, it can be set individually when entering Over/Under Checkweighing parameters.</p> <p>A low and a high weight value must be entered. These weights and all weights within this range are treated as being within tolerance.</p> <p>The target weight has to be entered as an absolute weight, upper and lower tolerances as deviations in weight from the target weight.</p> <p>The target weight has to be entered as an absolute weight, upper and lower tolerances as deviations in percent from the target weight.</p> <p>Not possible for counting.</p>
<p><b>Default values</b></p> <p>Activate</p> <p>Relative weight</p> <p>Percent weight</p> <p>Relative pieces</p>	<p>If you always use the same tolerances for Over/Under Checkweighing, you can store these tolerances and thus avoid entering tolerances all the time.</p> <p>Activating usage of default tolerance values.</p> <ul style="list-style-type: none"> <li>• <b>Off</b> Default tolerance values not used</li> <li>• <b>On</b> Default tolerance values used</li> </ul> <p>Enter the weight values for Tolerance – and Tolerance +.</p> <p>Enter the percentages for Tolerance – and Tolerance +.</p> <p>Enter Tolerance – and Tolerance + in pieces.</p>
<p><b>Output</b></p> <p>Setpoint tol–</p> <p>Good print</p>	<p>Setting display and printing options.</p> <p>When Setpoint tol– is reached, the coloured display will change from the "Setpoint tol–" colour to the "Tolerance–" colour.</p> <p>This setpoint is available on the optional digital I/O interface as well.</p> <p>This feature can be used to show the "Tolerance –" colour when you are already near the target or if you need an additional setpoint for I/O control.</p> <p>Possible settings: <b>0</b> ... 100 % (of the Tolerance – value)</p> <p>Automatic printout</p> <ul style="list-style-type: none"> <li>• <b>Off</b> No automatic printout</li> <li>• <b>On</b> Automatic printout when a stable weight value within the tolerance values exists</li> </ul>

**Application → Data storage – Setting data base parameters**

<b>Descr. field</b>	The description field can be used to expand each target record by one auxiliary field. This field can be used for an article description, article number or any other information on the record. It will be stored as part of the target record, it can be displayed, printed or transferred. The description field has a maximum length of 40 characters.
Activate	Activating description field for identifying sets of Over/Under Checkweighing parameters. <ul style="list-style-type: none"> <li>• <b>Off</b> No possibility to enter a value in the description field during target record definition. The content of already existing description fields is not affected.</li> <li>• <b>On</b> During target record entry you are asked to enter a value in the description field.</li> </ul>
Descriptor	Enter a name for the description field. Factory setting: Item.
<b>Article name</b>	With each target record an article name can be stored.
Activate	<ul style="list-style-type: none"> <li>• <b>Off</b> No possibility to enter an article name during target record definition. The content of already existing article names is not affected.</li> <li>• <b>On</b> During target record entry you are asked to enter an article name.</li> </ul>
<b>Article number</b>	With each target record an article number can be stored.
Activate	<ul style="list-style-type: none"> <li>• <b>Off</b> No possibility to enter an article number during target record definition. The content of already existing article numbers is not affected.</li> <li>• <b>On</b> During target record entry you are asked to enter an article number</li> </ul>
<b>Delete all</b>	Delete all records of the database.
Sure ?	A safety prompt is displayed before deleting the database records.
<b>Delete record</b>	Delete a single record in the database.
xx	Enter number of the record to be deleted
Notes	<ul style="list-style-type: none"> <li>• There is a SICS command available to write a target record including, description field, article name and article number.</li> <li>• To search for the contents of the description field or for article names and numbers, the entered data must be unique.</li> </ul>

**Application → Count – Setting reference**

<b>Reference</b>	Presetting the number of reference pieces for counting. Factory setting: 10 pieces
Note	To activate the counting application you need to activate the corresponding soft keys, too, see Terminal menu block.

### Application -> Log files – Setting up logfiles

<p><b>Alibi Log</b></p> <p>Activate</p> <p>Item 7 ... Item 10</p> <p>Delete all records</p>	<p>Setting up Alibi log file.</p> <p>If set to ON, all weighings are saved in a log file</p> <p>You can add additional information to that required by W &amp; M regulations.</p> <ol style="list-style-type: none"> <li>1. Select item number.</li> <li>2. Assign the item contents.</li> </ol> <p>A safety prompt is displayed before deleting all stored alibi records.</p>
<p><b>Routine Test Log</b></p> <p>Days</p> <p>External test</p> <p>Internal test</p> <p>Delete all records</p>	<p>Setting up routine calibration test for your scale.</p> <p>Enter interval of routine test</p> <ul style="list-style-type: none"> <li>• Test weight      Enter the test weight value</li> <li>• Weight name      Enter weight name</li> <li>• Tolerance      Enter tolerance for passing the routine calibration test</li> <li>• Yes      for weighing platforms with an internal calibration weight</li> <li>• No      for weighing platforms without an internal calibration weight</li> </ul> <p>A safety prompt is displayed before deleting all stored routine test records.</p>

### Application – Totalise – Activating/deactivating totalisation

<p><b>Activate</b></p>	<p>Activate/deactivate totalisation</p> <p>Totalisation is possible for piece counting and OverUnder Checkweighing as well.</p>
------------------------	---

### Application -> Reset – Resetting application settings to factory settings

<p><b>Perform reset ?</b></p>	<p>Confirmation inquiry</p> <ul style="list-style-type: none"> <li>• Reset the application settings to factory settings with <b>YES</b>.</li> <li>• Do not reset application settings with <b>NO</b>.</li> </ul>
-------------------------------	--

## 4.5 Terminal menu block

Factory settings are printed in **bold** in the following overview.

### 4.5.1 Overview

Level 1	Level 2	Level 3	Level 4	Level 5	Level 6	
Device	Language	<b>English</b> , German, French, Spanish, Italian, ...				
	Sleep / Power off	<b>Off</b> , 1 minute, 3 minutes, 5 minutes, 15 minutes, 30 minutes				
	Display	Layout	<b>Default</b> , 3-Line mode, Color mode			
		Auxiliary line 1 ... 3	Not used, <b>Date &amp; Time</b> , Gross, Net, Tare, High Resolution, ID1, ID2, ID3, Dev. identifier, Dev. location, Target, Descr. field, Deviation, Average PW, Reference count, Quantity, Record number, Article name, Article number, Total net, n, User name			
		Contrast	1 ... <b>10</b>			
		Brightness	1 ... <b>10</b>			
		Backlight	off, 5 seconds, 10 seconds, 30 seconds, 1 minutes, <b>On</b>			
		Weight hold	<b>0 s</b> ... 10 s			
		Stealth mode	On, <b>Off</b>			
		Colours	Default color, < MinWeigh, < SP.Tolerance-, < Tolerance-, Good range, > Tolerance+	Yellow, Light blue, <b>Dark blue</b> (< MinWeigh), Red, Purple, Green, Orange, Light green, Pink, <b>White</b> (Default colour)		
		Colour mode	Continuous, Stable			
IDs		ID1, ID2, ID3				



Level 1	Level 2	Level 3	Level 4	Level 5	Level 6	
Device	Keyboard	Key lock	Power, Clear, UnitSwitch, Info, Transfer, QuickSelect	Lock, <b>Unlock</b>		
		Info key	Item 1 ... Item 27	Not used, Date & Time, Gross, Net, Tare, HighRes & Net, ID1, ID2, ID3, Dev. identifier, Dev. location, Dev. name, SNR Terminal, SNR Scale 1, Firmware Vers., Target, Tolerance-, Tolerance+, Tolerance type, Descr. field Deviation, Average PW, Reference count, Quantity, Record number, Article name, Article number, Total net, n		
		Soft keys	Page 1, Page 2, Page 3	Soft key x-1 ... x-5	<b>Not used</b> , Target, Recall, Store, Take away, To zero, ID1, ID2, ID3, Reference n, Average PW, Switch scale, Plus, Total	
	Date & Time	Format	<b>EU</b> , US			
			Date	<b>dd/mm/yyyy</b> (EU), mm/dd/yyyy (US)		
			Time	hh:mm:ss		
			Meridian	AM, PM		
			Calender	On, <b>Off</b>		
	Beeper	<b>On</b> , Off				
	Information	Identification, Location				
	User management	Edit user	User 1 ... User 20	User name, Profile, Password, Language, User ID		
		Activate	On, <b>Off</b>			
Delete all						
Del. Profile		User No. xx				
Access	Supervisor	Password				
Reset	Perform reset ?					

## 4.5.2 Description of the Terminal menu block









### Terminal → Device – General device settings

<b>Language</b>	Selecting the language of the operator interface Possible languages: <b>English</b> , German, French, Spanish, Italian, Chinese We will expand the available languages continuously.
<b>Sleep</b> (User access)	This menu item only appears on devices in mains operation. When Sleep is activated, the device switches off display and backlighting after the time period set when not in use and gross weight is 0. Display and backlighting are switched on again by pressing a key or if the weight changes. Possible settings: <b>Off</b> , 1 min, 3 min, 5 min, 15 min, 30 min (approximate values)
<b>Power Off</b> (User access)	This menu item only appears on devices in battery operation. When Power Off is activated, the device switches itself off automatically after the time period set when not in use. After this, it must be switched on again using  . Possible settings: <b>Off</b> , 1 min, 3 min, 5 min, 15 min, 30 min (approximate values)

<b>Display</b>	Configuring the display window. For details see Introduction.
Layout	Selecting the presentation of the weight value. Possible settings: <b>Default</b> , 3-Line mode, Color mode
Auxiliary line 1 ...	Selecting the contents of the auxiliary display lines. 1. Select auxiliary line number
Auxiliary line 3	2. Assign contents to the selected line.
Contrast (User access)	Setting the contrast of the display. Possible settings: 1 ... <b>10</b>
Brightness (User access)	Setting the brightness of the display. Possible settings: 1 ... <b>10</b>
Backlight (User access)	Setting whether and after which time the background lighting will be switched off. Devices with a storage battery switch the background lighting off automatically by default when no action takes place at the device for approx. 5 seconds. Possible settings: Off (no background lighting), 5 sec, 10 sec, 30 sec, 1 min, <b>On</b> (background lighting always on) (approximate values)
Weight hold	Setting how long the weighing result is frozen in the display after the transfer key  has been pressed or auto print was generated. Possible settings: <b>0 s</b> ... 10 s
Stealth mode	With stealth mode on, there is no weight display, only the coloured display for "too light", "good" and "too heavy". Not available if the scale is approved.
Colours	Configuring colour setting for default, < MinWeigh and Over/Under Checkweighing. The device offers 10 predefined colours which can be assigned to the different conditions. 1. Select status. 2. Assign colour to the selected status.
Colour mode	Setting the way of changing display colour <ul style="list-style-type: none"> <li>• Continuous Change in colour with stable or dynamic weight values</li> <li>• Stable Change in colour only when the weight value is stable</li> </ul> For default colour settings see below.
IDs	Giving a name to the IDs
ID1, ID2, ID3	To each ID the following can be assigned: <ul style="list-style-type: none"> <li>• Name Enter a description of the ID for printout/datatransfer, e.g., "Lot"</li> <li>• Value Enter a default value for the ID, e.g., "123"</li> </ul>

**Default colour settings**

Condition	Default	Optional
< MinWeigh	Dark blue	Purple Orange Light green Pink
< Tolerance-	Red	
< SP.Tolerance-	Light blue	
Good range	Green	
> Tolerance+	Yellow	
Default colour	White	

<b>Keyboard</b>	Switching keys on/off and setting info key.
Key lock	Selecting keys to lock/unlock. Possible keys: Power (  ), Clear (  ), Unit switch (  ), Info (  ), Transfer (  ), Quick Select (  )
Info key	Configuring up to 27 items to be displayed using the info key (  ). 1. Select the item to be configured (Item 1 ... Item 27). 2. Assign contents.
Soft keys	Configuring the soft keys. Unless a soft key is configured there is no Over/Under Checkweighing or counting functionality. The soft keys are organised in two pages (lines) of 5 function keys each. 1. Select the page to be configured (Page 1, Page 2, Page 3). 2. Select the position (Soft key x-1 ... Soft key x-5). 3. Assign contents. For possible soft keys refer to the Introduction.
Note	<ul style="list-style-type: none"> <li>• If you want to lock the tare key (  ) and/or the zero key (  ) ask the METTLER TOLEDO service technician.</li> <li>• Locked keys cannot be activated by the user, but the supervisor can still activate these keys by entering his password</li> </ul>

<b>Date &amp; Time</b>	Setting date and time.
Format	Selecting date format. Possible settings: EU, US
Date	Setting date in the selected format: dd/mm/yyyy (EU) or mm/dd/yyyy (US)
Time	Setting time in the following format: hh:mm:ss
Meridian	For US format only: Setting AM/PM
Calender	Display a calender sheet in the right bottom edge of the display

<b>Beeper</b>	Each keystroke is confirmed by a short beep. Switching beeper on/off.
<b>Information</b>	Entering device information to identify the device according to your company's naming conventions.
Identification	Entering device identification
Location	Entering device location
<b>Note</b>	This device information can be used as follows: <ul style="list-style-type: none"> <li>• to be displayed in the auxiliary lines of the display</li> <li>• to be displayed via <b>i</b></li> <li>• to be printed/transferred together with the weight value</li> </ul> <p>In addition <i>Device name</i> provides the complete type information already entered in the factory, e.g., ICS649a-check-A15/t.</p>

### Terminal – User management

<b>Edit User</b>	Configuring user profiles.
User 1 ... User 20	<ul style="list-style-type: none"> <li>• User Name     Enter user name, max. xx characters</li> <li>• Profile        Assign profile: User or Supervisor</li> <li>• Password      Define password, max. xx characters</li> <li>• Language      Assign user language</li> <li>• User ID        Define user ID, e.g., personnel number</li> </ul>
<b>Activate</b>	Activating/deactivating user management
<b>Delete all</b>	Delete all user profiles
<b>Delete Profile</b>	Selecting a single user profile to be deleted

### Terminal → Access – Password for Supervisor menu access

<b>Supervisor</b>	Password entry for Supervisor menu access.
Password	Request to enter password. → Enter password.
Retype code	Request to repeat the password entry. → Enter password again.
<b>Note</b>	The password can consist of up to 6 characters.

**Terminal -> Reset – Resetting terminal settings to factory settings**

<b>Perform reset ?</b>	Confirmation inquiry <ul style="list-style-type: none"> <li>• Reset the terminal settings to factory settings with <b>YES</b>.</li> <li>• Do not reset terminal settings with <b>NO</b>.</li> </ul>
------------------------	---

**4.6****Communication menu block**

For detailed information on interface protocols and commands refer to the following documents:

- SICS Reference manual
- MT continuous Reference manual

The Communication menu block consists of the following subblocks:

- COM 1      Parameter settings for the standard RS232 interface COM 1.
  - COM 2      Parameter settings for the optional interface COM 2.
  - COM 3      Parameter settings for the optional interface COM 3 (not for .../c version).
- The interfaces identify themselves. Therefore only those menu settings appear which are relevant for the individual interface.

If no optional interface is installed, the COM 2 and COM 3 menus will not appear.

Templates    Define templates to be selected via COM x -> Printer -> Template.

## 4.6.1

## Standard settings

		COM1	COM2/COM3				
		RS232	RS232	RS422/ RS485	Ethernet	USB	WLAN
Mode	Print	✓	✓	✓	✓	–	✓
	Auto print	✓	✓	✓	✓	–	✓
	Instant print	✓	✓	✓	✓	–	✓
	Continuous <sup>1)</sup>	✓	✓	✓	✓	✓	✓
	Dialog <sup>1)</sup>	Factory setting	Factory setting	Factory setting	Factory setting	Factory setting	Factory setting
	External input	✓	✓	✓	✓	✓	✓
	Demand mode <sup>2)</sup>	✓	✓	✓	✓	–	✓
	Demand m auto <sup>2)</sup>	✓	✓	✓	✓	–	✓
	Cont.-weight <sup>2)</sup>	✓	✓	✓	✓	✓	✓
	Cont.-count	✓	✓	✓	✓	✓	✓
Printer		✓	✓	✓	✓	–	✓
Destination		✓	✓	✓	✓	✓	✓
Parameter	Baud	9600	9600	9600	–	–	–
	Parity	8 none	8 none	8 none	–	–	–
	Handshake	✓	✓	✓	–	–	–
	RS Type	–	–	✓	–	–	–
	Net Address	–	–	✓	–	–	–
	Checksum	✓	✓	✓	✓	–	✓
	STX	✓	✓	✓	✓	–	✓
	Print G	✓	✓	✓	✓	–	✓
	Load resistor	–	–	✓	–	–	–

<sup>1)</sup> for more information see Reference manual "MT-SICS for ICS4xx"

<sup>2)</sup> for more information see Reference manual "MT-Demand and Continuous", not recommended for new installations

#### 4.6.2 Overview RS232 / RS422 / RS485 menu blocks (COM 1 / COM 2 / COM 3)



Level 1	Level 2	Level 3	Level 4	
Mode	Print, Auto print, Instant print, Continuous, Dialog, External input, Demand mode, Demand m auto, Cont.-Weight, Cont.-count			
Printer	Type	<b>ASCII printer</b> , Label printer, GA46 printer		
	Print Template	<b>Standard</b> , Template 1 ... Template 5		
	Plus Template	<b>Off</b> , Template 1 ... Template 5		
	Total Template	<b>Off</b> , Template 1 ... Template 5		
	ACII Format	Line format	<b>Multiple</b> , Single, Fixed	
		Line length	1 ... <b>24</b> ... 100	
		Separator	. , : ; - _ / \ Space	
		Expanded	On, <b>Off</b>	
		Add line feed	<b>0</b> ... 9	
Destination	<b>Off</b> , Tare preset, ID1, ID2, Target, Average PW, Recall			
Parameter	Baud	300, 600, ..., 57600, 115200 baud		
	Parity	7 none, 8 none, 7 odd, 8 odd, 7 even, 8 even		
	Handshake	<b>Off</b> , Xon - Xoff		
	RS Type	<b>RS422</b> , RS485		
	Net Address	<b>0</b> ... 31		
	Checksum	On, <b>Off</b>		
	STX	On, <b>Off</b>		
	Print G	On, <b>Off</b>		
Load resistor	On, <b>Off</b>			
Reset	Perform Reset ?			



### 4.6.3

### Description of the RS232 / RS422 / RS485 menu blocks (COM 1 / COM 2)

#### Communication -> COM x -> Mode – Operating mode of the serial interface

<b>Print</b>	Manual data output to the printer with 
<b>Auto print</b>	Automatic output of stable results to the printer (e.g., for series weighing operations)
<b>Instant print</b>	Immediate manual data output to the printer with  (not verifiable)
<b>Continuous</b>	Ongoing output of all weight values via the interface
<b>Dialog</b>	Bi-directional communication via MT-SICS commands, control of the device via PC
<b>External input</b>	Input other than via terminal keypad. What the input is used for is defined in the Destination menu block
<b>Demand mode</b>	Manual data transmission with 
<b>Demand m auto</b>	Automatic transmission of stable results (e.g., for series weighing operations)
<b>Cont.-Weight</b>	TOLEDO Continuous mode
<b>Cont.-count</b>	TOLEDO Continuous mode with counting results
<b>Note</b>	<p>Printing conditions for <i>Auto print</i> and <i>Demand m auto</i>:</p> <ul style="list-style-type: none"> <li>• The weight must be heavier than 9 display increments.</li> <li>• A weight change of at least 9 display increments is required to initiate the next printout</li> </ul>

## Communication → COM x → Printer – Settings for protocol printout

<b>Type</b>	<p>Selecting printer type from the following:  <b>ASCII printer</b>, Label printer, GA46 printer</p> <p><b>Note</b>  If Label printer is selected, the transmitted data does not include the name of the variable, e.g., date, gross, ID1, but the value and, if appropriate, the unit as a separate line. This allows the label printer to fill its template with the required data.</p>
<b>Print Template</b>	<p>Selecting protocol printout for straight weighing  Possible settings: <b>Standard</b>, Template 1 ... Template 5</p>
<b>Plus Template</b>	<p>Selecting protocol printout for totalising  Possible settings: <b>Off</b>, Template 1 ... Template 5</p>
<b>Total Template</b>	<p>Selecting protocol printout for printing the total  Possible settings: <b>Off</b>, Template 1 ... Template 5</p>
<b>ASCII Format</b>	<p>Selecting formats for the protocol printout.</p>
Line format	<p>Selecting line format from the following:</p> <ul style="list-style-type: none"> <li>• <b>Multiple</b> (multiple lines)</li> <li>• Single (single line)</li> <li>• Fixed (Records output in single lines; every record includes the number of characters that was defined under <code>Line length</code>)</li> </ul>
Line length	<p>Setting line length  Possible settings: 0 to 100 characters  Factory setting: 24 characters  This item is only displayed for the line formats <code>Multiple</code> and <code>Fixed</code></p>
Separator	<p>Selecting the separator  Possible settings: <code>,</code> <code>;</code> <code>:</code> <code>\</code> <code>_</code> <code>-</code> and space  This item is only displayed for the line format <code>Single</code></p>
Expanded	<p>Printout with bigger font size on METTLER TOLEDO printers.</p>
Add line feed	<p>Adding line feeds  Possible settings: <b>0</b> ... 9</p>

**Communication → COM x → Destination – Destination for barcode input**

<b>None</b>	Input destination is not predefined. The input will be shown on the display, you can decide what to do with the input.
<b>Tare preset</b>	Input via barcode is recognised as tare preset
<b>ID1, ID2, ID3</b>	Input via barcode is recognised as ID1, ID2 resp. ID3
<b>User ID</b>	Input via barcode is recognised as User ID
<b>Target</b>	Input via barcode is recognised as target value
<b>Average PW</b>	Input via barcode is recognised as average piece weight
<b>Recall</b>	Input via barcode is recognised as record number

**Communication → COM x → Parameter – Communication parameters**

<b>Baud</b>	Selecting baud rate Possible settings: 300, 600, 1200, 2400, 4800, <b>9600</b> , 19200, 38400, 57600, 115200
<b>Parity</b>	Selecting parity Possible settings: 7 none, <b>8 none</b> , 7 odd, 8 odd, 7 even, 8 even
<b>Handshake</b>	Selecting handshake Possible settings: <b>Off</b> , Xon-Xoff
<b>RS Type</b>	Selecting type of the optional RS422/RS485 interface: RS422 or RS485
<b>Net Address</b>	Assigning network address: 0 ... 31, only for RS485
<b>Checksum</b>	Activating/deactivating checksum byte
<b>STX</b>	Activating/deactivating STX If STX is enabled, the STX signal (0x02) is sent at the beginning of each output string that is sent via the interface.
<b>Print G</b>	This functionality can only be enabled if one of the Demand mode templates is selected. If it is enabled, the gross weight is marked with "G". <b>Examples</b> Print G enabled, no tare:     _ _2.001_kg_G Print G disabled, no tare     _ _2.001_kg Print G enabled, tare active:  _ _2.025_kg_G_ _2.000_kg_T_ _0.025_kg_NET Print G disabled, tare active: _ _2.025_kg_ _2.000_kg_T_ _0.025_kg_NET
<b>Load resistor</b>	Only for the optional RS422/RS485 interface To avoid reflexions on a network, we recommend to make a defined termination. To this purpose the load resistor within the terminal can be used. When set to "On", a resistor of approx. 100 Ω between the signal lines is enabled

**Communication → COM x → Reset COM x –  
Resetting communication settings to factory settings**

<b>Perform reset ?</b>	Confirmation inquiry <ul style="list-style-type: none"> <li>• Reset the communication settings to factory settings with <b>YES</b>.</li> <li>• Do not reset communication settings with <b>NO</b>.</li> </ul>
------------------------	---

**4.6.4 Digital I/O menu blocks**

Level 1	Level 2	Level 3
Input	Input pin 1 ... Input pin 4	<b>Off</b> , Zero, Tare, Transfer, Switch, Clear, Info, Target, Take away
Output	Ready, Stable, Tare, Zero, < MinWeigh, >= MinWeigh, Underload, Overload, <= Setpoint 1, > Setpoint 1, <= Setpoint 2, > Setpoint 2, Star, SP.Tolerance-, < Tolerance-, Good range, Target, > Tolerance+	<b>Off</b> , Output Pin 1 ... Output Pin 4
Setpoints	Setpoint 1, Setpoint 2	
Output mode	<b>Continuous</b> , Stable	
Reset COM 2	Perform reset ?	

**COM x (Digital I/O) → Input/Output – Configuring inputs/outputs**

**Configuring inputs**

1. Select an input pin.
2. Assign an input signal to the selected input pin.

**Configuring outputs**

1. Select an output signal.
2. Assign an output pin.

**COM x (Digital I/O) → Setpoints – Entering values**

<b>Setpoint 1</b>	Enter value for setpoint 1
<b>Setpoint 2</b>	Enter value for setpoint 2

### COM x (Digital I/O) -> Output Mode – Behaviour of the digital outputs

<b>Continuous</b>	Digital outputs are updated continuously
<b>Stable</b>	Digital outputs are updated only when the weight is stable

### COM x (Digital I/O) -> Reset COM 3 – Resetting communication settings to factory settings

<b>Perform reset ?</b>	Confirmation inquiry <ul style="list-style-type: none"> <li>Reset the Digital I/O settings to factory settings with <b>YES</b>.</li> <li>Do not reset Digital I/O settings with <b>NO</b>.</li> </ul>
------------------------	---

#### 4.6.5

#### Ethernet menu block

Item	Reference
Mode	See RS232 / RS422 / RS485 menu blocks
Printer	
Destination	
Parameter	
DHCP	If DHCP is set to "On", the device will receive the IP address automatically. Then IP address, Subnet mask and Gateway are read-only fields
IP address	Enter/display IP address
Subnet mask	Enter/display Subnet address
Gateway	Enter/display Gateway address
Reset Ethernet	See RS232 / RS422 / RS485 menu blocks

#### 4.6.6

#### USB menu block

Item	Reference
Mode	See RS232 / RS422 / RS485 menu blocks
Destination	
Checksum	
STX	
Reset USB	

#### 4.6.7 WLAN menu block

Level 1	Level 2	Level 3
Mode	See RS232 / RS422 / RS485 menu blocks.	
Printer		
Destination		
Parameter		
IP address	Enter IP address.	
Subnet mask	Enter Subnet address.	
Gateway	Enter Gateway address.	
Wireless settings	SSID	Enter SSID
	Encryption	<b>Off</b> , WEP, WPA
	WEP Settings	64 Bit, 128 Bit
	WEP key	Key 1, ... Key 4
	WPA Settings	WPA-TKIP, WPA2-AES
	Password	Enter password
Status	Display the current status, e.g., connection status, signal strength.	
Reset COM	See RS232 / RS422 / RS485 menu blocks.	

#### 4.6.8 Templates menu block

Level 1	Level 2	Level 3
Template 1 ... Template 5	Line 1 ... Line 25	<b>Not used</b> , Header, Date, Time, Gross, Net, Tare, High resolution, ID1, ID2, ID3, Dev. identifier, Dev. location, SNR Terminal, SNR Scale 1, Target, Tolerance-, Tolerance+, Tolerance type, Descr. field, Deviation, Weight position, Average PW, Reference count, Quantity, Record number, Article name, Article number, Total net, n, User name, Star line, New line, Form feed,

#### Configuring templates

1. Select a template.
2. Select the line to be configured.
3. Assign the line contents.





The header can be specified via SICS command I31, see Reference manual "MT-SICS for ICS6xx".

## 4.7

### Maintenance menu block

<p><b>Test Scale</b></p>	<p>Testing the scale</p> <p>Scales with an analog interface will offer the test procedure described below. Scales with an IDNet interface and an internal calibration weight perform an automatic calibration check.</p> <ol style="list-style-type: none"> <li>1. The scale checks the zero point. –0– appears in the display.</li> <li>2. The test weight value flashes in the display. If necessary, change the weight value displayed using <b>→T←</b>.</li> <li>3. Put the test weight on the scale and confirm with <b>↵</b>. The scale checks the test weight.</li> <li>4. After the test is completed, the deviation from the last calibration briefly appears in the display, ideally *d=0.0g, after which the device changes to the next menu item.</li> </ol>
<p><b>Keyboard Test</b></p> <p>Start ?</p>	<p>Keyboard test</p> <ol style="list-style-type: none"> <li>1. Press <b>↵</b> to start the keyboard test.</li> <li>2. Press the keys in the displayed order. If the key works, the device switches to the next key.</li> </ol>
<p><b>Display Test</b></p> <p>Start ?</p>	<p>Display test.</p> <ol style="list-style-type: none"> <li>1. Press <b>↵</b> to start the display test. A checkerboard pattern is displayed in all colours.</li> <li>2. Press <b>↵</b> to leave the display test.</li> </ol> <p>The display works properly if the dark and bright fields are displayed without missing pixels.</p>
<p><b>Serial number</b></p> <p>Start ?</p>	<p>Display of the serial numbers</p> <ol style="list-style-type: none"> <li>1. Press <b>↵</b>. The serial numbers of the weighing terminal and the active weighing platform are displayed.</li> <li>2. Press <b>⏻</b> to leave the item.</li> </ol>
<p><b>Print Setup</b></p> <p>Start ?</p>	<p>Printout of a list of all menu settings</p> <ol style="list-style-type: none"> <li>1. Press <b>↵</b>. A safety prompt is displayed.</li> <li>2. Press <b>↵</b> again to start printing.</li> </ol>

<b>Print Records</b> Start ?	Printout of a list of the target value records stored in the database. <ol style="list-style-type: none"><li>1. Press .</li><li>A safety prompt is displayed.</li><li>2. Press  again to start printing.</li></ol>
<b>Reset All</b> Perform reset ?	Reset all settings to factory settings Confirmation inquiry <ul style="list-style-type: none"><li>• Reset all settings to factory settings with <b>YES</b>.</li><li>• Do not reset settings with <b>NO</b>.</li></ul>



## 5 Quick Select menu

### 5.1 Quick Select menu overview

The Quick Select menu offers access to logout, routine test and several log files, depending on your configuration.

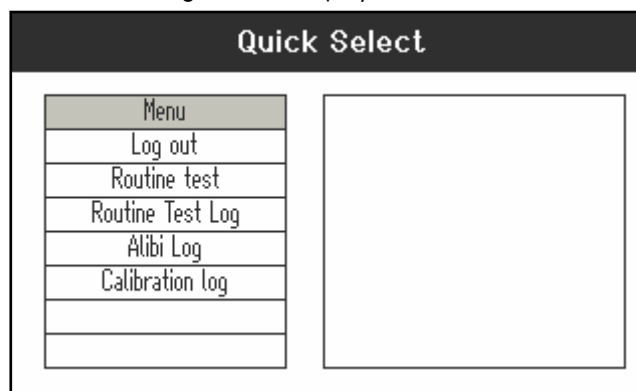

→ Press .

The following menu is displayed.



The example shows the Quick Select menu with the maximum of configurable items.

### 5.2 Entering main menu

→ In weighing mode press  and then .

The main menu is displayed without a long key press.

### 5.3 Logout

#### Prerequisite

✓ User management is activated under `Terminal -> User Management`.



- Logout is described in the Operation chapter.
- Always log out when leaving the terminal in order to prevent unauthorised persons from working on it.

## 5.4 Performing routine test

By performing a routine test you can check the calibration of your scale regularly.

### Prerequisite

✓ Routine test parameters are set under *Application* -> *Log files*.



If an interval for the routine test is defined (*Days* > 0), the device automatically asks you to perform the routine test.

### With external weight

1. Unload the scale.
2. Select *Routine Test* in the *Quick Select* menu using the cursor keys  $\wedge$  /  $\vee$  and confirm with  $\rightarrow$ .

You are asked to put the indicated weight on the platform.

3. When the required weight is put on the platform, press  $\rightarrow$ .

The routine test is carried out and the following test protocol is displayed for a short time:

Routine test	
Routine test passed!	
Rec. no.:	9
Date & Time:	08/07/2010 13:58:50
User name:	ABC
Test weight:	1.50 kg
Weight name:	W1
Tolerance:	0.10 kg
Result:	1.50 kg
Deviation:	0.00 kg

### With internal weight

1. Unload scale.
2. Select `Routine Test` in the Quick Select menu using the cursor keys `^`/`v` and confirm with `↵`.

The routine test is carried out and the following test protocol is displayed for a short time.

Routine test	
Routine test passed!	
Rec.no.:	9
Date & Time:	08/07/2010 13:58:50
User name:	ABC
Test weight:	Internal weight
Weight name:	W1
Tolerance:	n/a
Result:	n/a
Deviation:	n/a



- The results of the routine test are stored in the routine test log file.
- If the determined weight is not within the tolerance, test protocol is in red. Call the METTLER TOLEDO service technician.
- If an external test weight is defined, an external routine test is performed directly after the internal routine test.

## 5.5

### Calling up routine test log file

#### Prerequisite

- ✓ Routine test parameters are set under `Application -> Log files`.

#### Viewing routine test log file

1. Select `Routine Test Log` in the Quick Select menu using the cursor keys `^`/`v` and confirm with `↵`.

The routine test protocol of the last routine test is displayed.

Routine test passed!	
0002	Rec. no.: 11
0003	Date & Time: 21/07/2010 15:01:52
0004	User name: Richard Lebherz
0005	Test weight: 1.00 kg
0006	Weight name: A
0007	Tolerance: 0.01 kg
0008	Result: 1.00 kg
0009	Deviation: 0.00 kg
0010	
0011	

2. To view other routine test protocols use the cursor keys `^`/`v`.



## 5.6

### Printing routine test log file

1. When a routine test record is displayed, press  $\square \rightarrow$ .
2. In the next screen select either `Print selected record` to print a single record or `Print whole memory` to print all records.
3. Confirm selection with  $\square \rightarrow$ .  
The routine test log record(s) is(are) printed.

### Deleting routine test log file

Deleting routine test log files is carried out in the menu under `Application -> Log files -> Routine Test Log`.

### Calling up alibi log file

#### Prerequisite

✓ `Alibi Log` is activated under `Application -> Log files`.

#### Viewing alibi records

1. Select `Alibi Log` in the Quick Select menu using the cursor keys  $\wedge / \vee$  and confirm with  $\square \rightarrow$ .  
The alibi record of the last weighing operation is displayed.





Alibi Log	
000 008	Rec. no.: 000 017
000 009	Date & Time: 20/07/2010 13:27:41
000 010	Net: 5.48 kg
000 011	Tare: 0.00 kg
000 012	Gross: 5.48 kg
000 013	Scale number: 1
000 014	
000 015	
000 016	
000 017	

2. To view other alibi records use the cursor keys  $\wedge / \vee$ .

#### Printing alibi log file

1. When an alibi record is displayed, press  $\square \rightarrow$ .  
In the next screen you are given the following choice:
  - Print selected record
  - Print whole memory
  - Print today's records
  - Print records by number
  - Print records by date
2. Select the desired printing mode using the cursor keys  $\wedge / \vee$  and confirm with  $\square \rightarrow$ .
3. If `Print records by number` or `Print records by date` is selected, you are asked to enter start and end number respectively start and end date.  
The selected alibi record(s) is(are) printed.

### Searching alibi records

1. When an alibi record is displayed, press soft key .
  2. In the next screen use  to select the search criterion either `Search by date` or `Search by rec. no` (record number) and confirm with .
  3. Enter record number resp. date of the alibi record(s) you are looking for and confirm with .
- The desired alibi record(s) is(are) displayed.



### Deleting alibi log files

Deleting alibi log files is carried out in the menu under `Application -> Log files -> Alibi Log`.

## 5.7 Calling up calibration log file

For analog scales the results of calibration procedures are stored in the calibration log file.



### Viewing calibration log file

1. Select `Calibration Log` in the Quick Select menu using the cursor keys `^`/`v` and confirm with .
- The calibration record of the last calibration is displayed.

Calibration passed!	
001	Rec. no.: 1
002	Date & Time: 20/07/2010 12:04:18
003	User name:
004	Test weight: 60.00kg
005	Weight name:
006	Scale number: 1
007	Comments:
008	
009	
010	



2. To view other calibration records use the cursor keys `^`/`v`.

### Printing calibration records

1. When a calibration record is displayed, press .
  2. In the next screen select either `Print selected record` to print a single record or `Print whole memory` to print all records.
  3. Confirm selection with .
- The calibration record(s) is(are) printed.

## 6 Event and error messages

### 6.1 Error conditions

Error	Cause	Remedy
Display dark	• Backlighting set too dark	→ Set backlighting brighter.
	• No mains voltage	→ Check mains.
	• Unit switched off	→ Switch on unit.
	• Mains cable not plugged in	→ Plug in mains cable.
	• Brief fault	→ Switch device off and on again.
Weight display unstable	• Restless installation location	→ Adjust vibration adapter.
	• Draft	→ Avoid draft.
	• Restless weighing sample	→ Dynamic weighing.
	• Contact between weighing pan and/or weighing sample and surroundings	→ Remedy contact.
	• Mains fault	→ Check mains.
Incorrect weight display	• Incorrect zeroing	→ Unload scale, set to zero and repeat weighing operation.
	• Incorrect tare value	→ Clear tare.
	• Contact between weighing pan and/or weighing sample and surroundings	→ Remedy contact.
	• Weighing platform tilted	→ Level weighing platform.
	• Load plate not on the scale • Weighing range not reached	→ Place load plate on the scale. → Set to zero.
	• Weighing range exceeded	→ Unload scale. → Reduce preload.
	• Result not yet stable	→ If necessary, adjust vibration adapter.
"Attention: Approval invalid" alternating with metrological data	• Approval was tampered with	→ Call METTLER TOLEDO service technician.

## 6.2 Errors and warnings

### 6.2.1 Error messages

Error messages contain the following information:

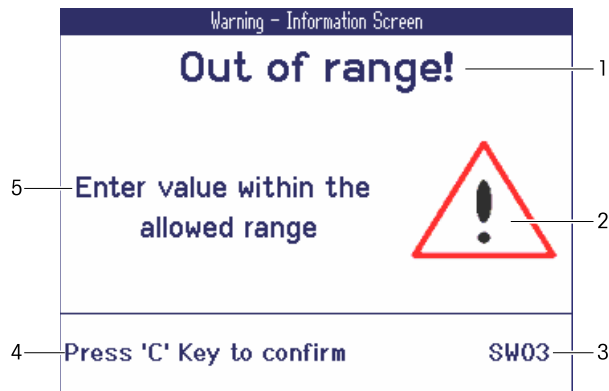

- 1 Error message
- 2 Warning symbol
- 3 Message identifier
- 4 How to clear the message
- 5 Remedy

### 6.2.2 Warnings

Warnings are displayed briefly and then disappear automatically.

#### Example

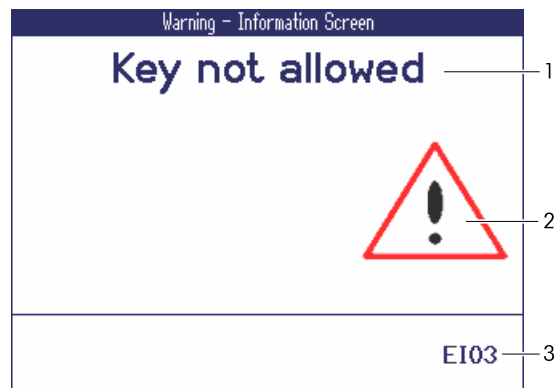

- 1 Warning
- 2 Warning symbol
- 3 Warning identifier

**6.2.3****Information**

Information screens are displayed briefly and then disappear automatically.

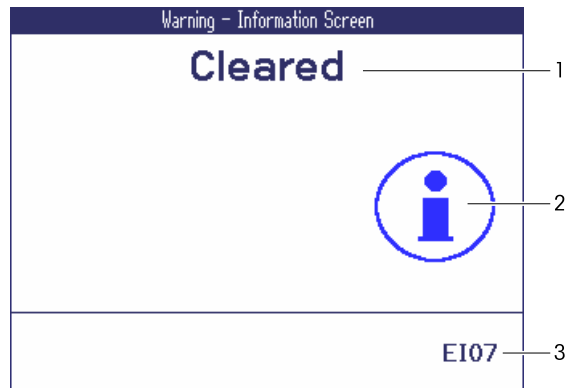
**Example**

- 1** Info message
- 2** Info symbol
- 3** Info identifier



## 6.3 Smart weighing counter / spanner icon

This weighing instrument features several control functions to monitor the condition of the device.

The METTLER TOLEDO service technician can setup and enable these functions.

This helps the user and the METTLER TOLEDO service technician to determine how the device is treated and what measures are needed to keep it in a good shape.

If the control functions triggers an alert, a message is shown.

You can confirm the message and continue to work with the weighing instrument. The spanner icon  lights up.

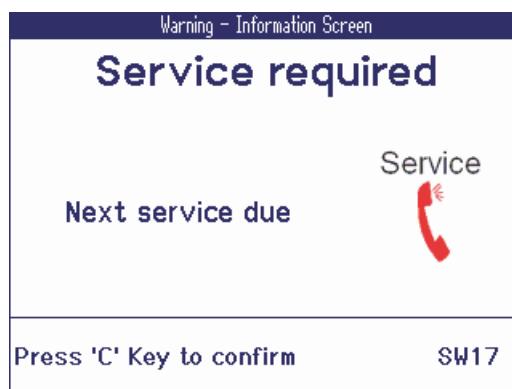

In case of an alert we strongly recommend calling the METTLER TOLEDO service technician

- to replace parts which are at the end of lifetime,
- to correct wrong settings,
- to educate operators about proper handling,
- to perform routine service work,
- to reset the alert.

The control functions monitor the following conditions:

- number of weighings
- number of overloads
- maximum weight
- zero commands and zero failures
- battery charging cycles
- power-on time
- date for the next service inspection

## 7 Technical data and accessories

### 7.1 Technical data weighing terminal

Housing	Stainless steel 1.4301 or AISI 304
Display	<ul style="list-style-type: none"> <li>• Color TFT graphical display, with backlighting</li> <li>• Size: 115 x 85 mm / 320 x 240 pixels</li> </ul>
Keyboard	<ul style="list-style-type: none"> <li>• Tactile-touch membrane keypad</li> <li>• Scratch-resistant labelling</li> </ul>
Protection type	<ul style="list-style-type: none"> <li>• Terminal IP68/IP69k</li> <li>• Standard weighing platform IP68/IP69k</li> <li>• Weighing platform with option load cell with KS+ coating IP68/IP69k</li> </ul>
Net weight	<ul style="list-style-type: none"> <li>• Terminal 2.3 kg / 5.1 lb</li> <li>• ICS649a-check-.../c 3.6 kg / 7.9 lb + weight of the weighing platform</li> </ul>
Mains connection	<ul style="list-style-type: none"> <li>• Direct connection to power supply (supply voltage fluctuation not exceeding <math>\pm 10</math> % of the rated voltage)</li> <li>• Rated voltage 100 ... 240 VAC / 50 ... 60 Hz / 300 mA</li> </ul>
Storage battery operation	<ul style="list-style-type: none"> <li>• Supply of device: 12 V <math>\equiv</math> / 2.5 A</li> <li>• If the supply voltage is interrupted, the device automatically switches over to storage battery operation</li> </ul>
Battery charger	<ul style="list-style-type: none"> <li>• Ambient conditions: 0 ... 40 °C / 32 ... 104 °F, dry environment</li> </ul>
Ambient conditions	<ul style="list-style-type: none"> <li>• Application indoor use only</li> <li>• Altitude up to 2,000 m</li> <li>• Temperature range Class III -10 ... 40 °C / 14 ... 104 °F</li> <li>• Temperature range Class II 0 ... 40 °C / 32 ... 104 °F</li> <li>• Overvoltage category II</li> <li>• Pollution degree 2</li> <li>• Humidity: Max. rel. humidity 80 % for temperatures up to 31 °C, decreasing linearly to 50 % rel. humidity at 40 °C</li> </ul>
Interfaces	<ul style="list-style-type: none"> <li>• 1 interface RS232 integrated</li> <li>• ICS649a-check-.../c:                             <ul style="list-style-type: none"> <li>– 1 additional optional communication interface possible</li> </ul> </li> <li>• ICS649a-check/d, ICS649a-check-.../f, ICS649a-check-.../t                             <ul style="list-style-type: none"> <li>– 2 additional optional communication interfaces possible</li> <li>– 1 additional scale interface possible</li> </ul> </li> </ul>
W & M approvals	<ul style="list-style-type: none"> <li>• OIML Class II, III, IIII</li> <li>• NTEP Class II, III</li> </ul>

### Applications

- Weighing
- Over/Under Checkweighing
- Piece counting
- Average weighing
- Totalising
- Alibi log file
- Routine test function
- Calibration log file
- User management

### Operating life with storage battery

The operating life during storage battery operation differs depending on the intensity of use, the configuration and the connected scale.

The following approximate values apply with standard RS232 interface and the brightness set to 5.

Weighing platform	Conditions	Duration
With 1 strain gauge weighing cell, e.g., ICS649a-check-A15...	10 % operation, 90 % power-off mode	150 h
	Continuous operation	15 h
With 4 strain gauge weighing cells, e.g., a floor scale	10 % operation, 90 % power-off mode	120 h
	Continuous operation	12 h
K line weighing platforms	10 % operation, 90 % power-off mode	60 h
	Continuous operation	6 h

**Dimensional drawing**

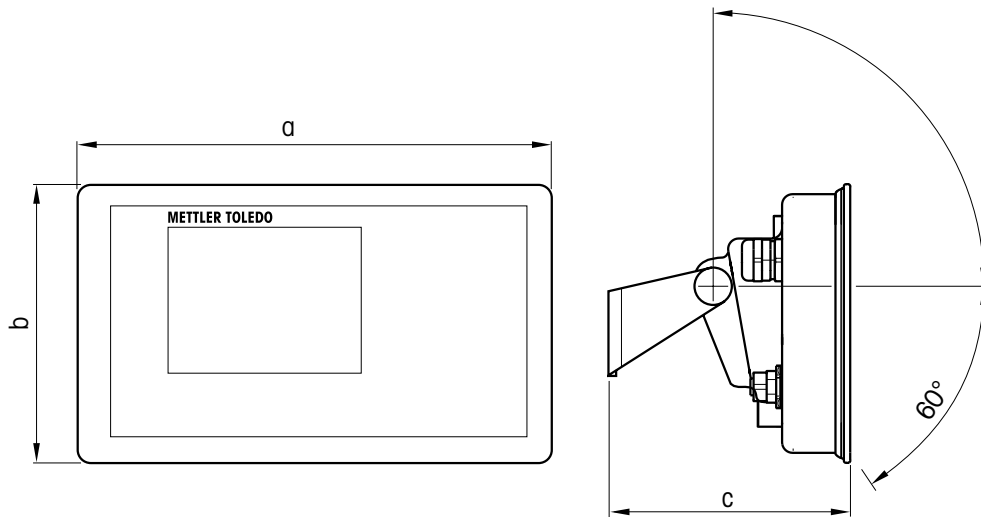

Dimension	[mm]	["]
<b>a</b>	260	10.24
<b>b</b>	170	6.70
<b>c</b>	114	4.49

## 7.2

### Technical data weighing platforms



- The size of the weighing platform (A, BB, B, BC, CC, QB, QC) is indicated at the end of the product name, e.g., ICS649a-check-A6.
- Other combinations of weighing range and readability can be adjusted by the METTLER TOLEDO service technician on site.
- The table below indicates the factory settings of weighing range and readability.

#### Weighing ranges and readability (factory setting)

Model	Settings in kg / g		Settings in lb	
	Range	Readability	Range	Readability
<b>A3</b>	1.5 kg / 3 kg	0.5 g / 1 g	2.5 lb / 5 lb	0.0005 lb / 0.001 lb
<b>A6, QA6</b>	3 kg / 6 kg	1 g / 2 g	5 lb / 10 lb	0.001 lb / 0.002 lb
<b>A15, QB15</b>	6 kg / 15 kg	2 g / 5 g	10 lb / 25 lb	0.002 lb / 0.005 lb
<b>BB30, B30, QB30</b>	15 kg / 30 kg	5 g / 10 g	25 lb / 50 lb	0.005 lb / 0.01 lb
<b>BB60, B60, BC60, CC60, QB60, QC60</b>	30 kg / 60 kg	10 g / 20 g	50 lb / 100 lb	0.01 lb / 0.02 lb
<b>BC150, B150, CC150, QC150</b>	60 kg / 150 kg	20 g / 50 g	100 lb / 250 lb	0.02 lb / 0.05 lb
<b>BC300, CC300</b>	150 kg / 300 kg	50 g / 100 g	250 lb / 500 lb	0.05 lb / 0.1 lb
<b>CC600</b>	300 kg / 600 kg	100 g / 200 g	500 lb / 1000 lb	0.1 lb / 0.2 lb

#### Operation limits – maximum static safe load

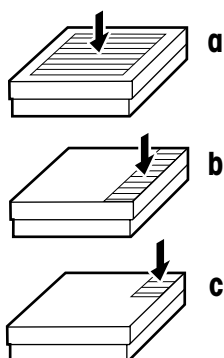

Model	a – center load	b – side load	c – corner load
<b>A</b>	30 kg / 60 lb	20 kg / 40 lb	10 kg / 20 lb
<b>BB</b>	100 kg / 200 lb	70 kg / 140 lb	35 kg / 70 lb
<b>B</b>	200 kg / 400 lb	140 kg / 280 lb	75 kg / 150 lb
<b>BC</b>	400 kg / 800 lb	300 kg / 600 lb	150 kg / 300 lb
<b>CC</b>	700 kg / 1400 lb	400 kg / 800 lb	200 kg / 400 lb
<b>QA</b>	15 kg / 30 lb	10 kg / 20 lb	5 kg / 10 lb
<b>QB</b>	100 kg / 200 lb	70 kg / 140 lb	35 kg / 70 lb
<b>QC</b>	200 kg / 400 lb	140 kg / 280 lb	75 kg / 150 lb

**Weights, approx. values**

<b>Model</b>	<b>Weight in kg</b>	<b>Weight in lb</b>
<b>A</b>	5.2	11.5
<b>BB</b>	7.4	16.3
<b>B</b>	12.7	28.0
<b>BC</b>	26.5	58.4
<b>CC</b>	35.0	77.2
<b>QA</b>	4.1	9.0
<b>QB</b>	7.8	17.2
<b>QC</b>	13.1	28.9

**Length of load cell cable for ICS649a-check-.../t**

<b>Weighing range</b>	<b>Length in m</b>	<b>Length in ft</b>
up to 30 kg / 50 lb	1.5	5
60 kg / 100 lb and higher	2.5	8

## Dimensional drawings

The size of the weighing platform (A, BB, B, BC, CC, QB) is indicated at the end of the product name, e.g., ICS649a-check-**A6**.

### Weighing platform

Front view

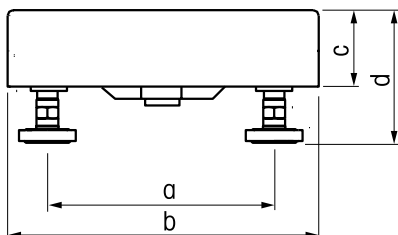

Side view

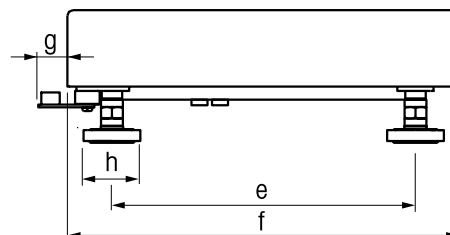

Dim.	A		BB		B		BC		CC		QA		QB		QC	
	[mm]	["]	[mm]	["]	[mm]	["]	[mm]	["]	[mm]	["]	[mm]	["]	[mm]	["]	[mm]	["]
<b>a</b>	175	6.89	235	9.25	335	13.19	435	17.13	503	19.80	170	6.69	233	9.17	392	15.43
<b>b</b>	240	9.45	300	11.81	400	15.75	500	19.69	600	23.62	229	9.02	305	12.01	457	17.99
<b>c</b>	56	2.20	57	2.24	57	2.24	70	2.76	79	3.11	56	2.20	57	2.24	60	2.36
<b>d</b>	95	3.74	97	3.82	100	3.94	108	4.25	130	5.12	95	3.74	108	4.25	100	3.94
<b>e</b>	235	9.25	335	13.19	435	17.13	587	23.11	724	28.50	170	6.69	245	9.65	397	15.63
<b>f</b>	300	11.81	400	15.75	500	19.69	650	25.59	800	31.50	229	9.02	305	12.01	457	17.99
<b>g</b>	22	0.87	15	0.59	15	0.59	15	0.59	21	0.83	22	0.87	15	0.59	15	0.59
<b>h</b>	Circle diameter: 30 mm / 1.18"; diagonal: 34 mm / 1.34"															

\* min. height = d, max. height = d + 15 mm / d + 0.59"

ICS649a-check-.../f

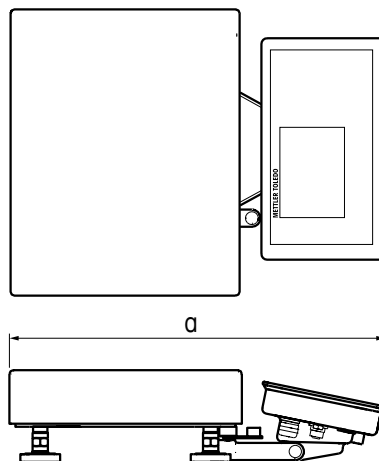

	A		BB		B		BC		CC		QA		QB		QC	
Dim.	[mm]	["]	[mm]	["]	[mm]	["]	[mm]	["]	[mm]	["]	[mm]	["]	[mm]	["]	[mm]	["]
<b>a</b>	418	16.46	485	19.09	581	22.87	681	26.81	772	30.39	407	16.02	489	19.25	640	25.10

ICS649a-check-.../c

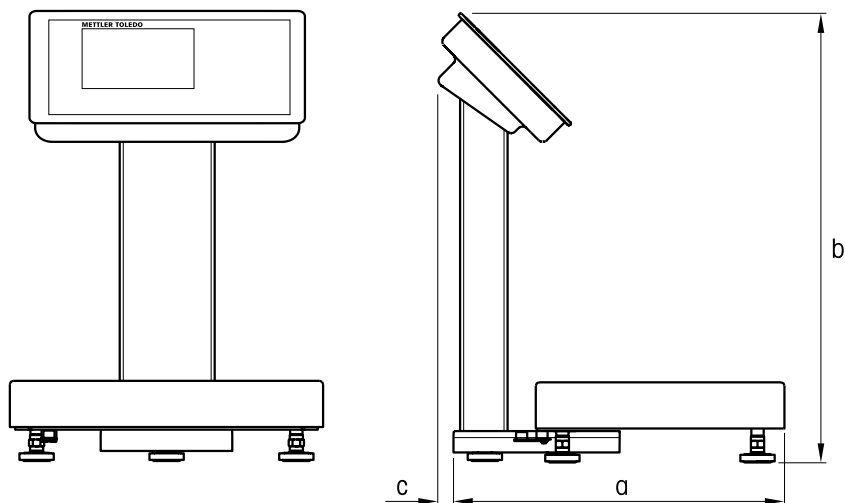

	A		BB		B		BC		CC		QA		QB		QC	
Dim.	[mm]	["]	[mm]	["]	[mm]	["]	[mm]	["]	[mm]	["]	[mm]	["]	[mm]	["]	[mm]	["]
<b>a</b>	337	13.27	404	15.91	500	19.69	600	23.62	691	27.2	326	12.83	408	16.06	559	22.01
<b>b</b>	412 mm / 16.22"															
<b>c</b>	34 mm / 1.34"															



## 7.3

### Accessories

<b>Printers</b>	<b>Order no.</b>
GA46 printer, RS232, incl. 8-pin M12 plug 2.5 m cable 0.4 m cable	22 019 925 22 019 926
<b>Retrofitable interfaces (conversion kits)</b>	<b>Order no.</b>
Kit must be fitted by a METTLER TOLEDO service technician	
RS232 conversion kit terminal version .../c version	22 012 112 22 012 117
RS422/RS485 conversion kit terminal version .../c version	22 012 113 22 012 118
Ethernet conversion kit terminal version .../c version	22 012 114 22 012 119
USB Device conversion kit terminal version .../c version	22 012 115 22 012 120
Digital I/O conversion kit, 4 outputs and 4 inputs terminal version .../c version	22 012 116 22 012 121
WLAN conversion kit terminal version .../c version	22 012 126 22 012 127
<b>Plugs</b>	<b>Order no.</b>
RS232 counter plug, 8 pin M12	22 021 105
RS485 counter plug, 6 pin M12	22 021 106
Ethernet counter plug, 4 pin, Coding D, M12	22 021 107
USB counter plug, 4 pin, Coding A, M12	22 021 108

<b>Cables (always delivered with 90° angled M12 plug)</b>	<b>Order no.</b>
RS232 cable for SICS scale, 8 pin M12 <-> 9 pin sub D plug, 3 m	22 021 088
RS232 cable for PC, 8 pin M12 <-> 9 pin sub D receptacle, 3 m	22 021 087
RS422/RS485 cable, 6 pin M12 <-> open ends, 3 m	22 021 089
Ethernet 10/100 Base T twisted pair cable, 4 pin M12 Coding D <-> RJ45 5 m	22 021 090
20 m	22 021 091
USB adapter cable, 4 pin M12 Coding A <-> USB series A receptacle 0.2 m	22 021 122
5 m	22 021 123
USB cable, connection to PC, 4 pin M12 Coding A <-> USB series A plug, 3 m	22 021 092
USB cable, connection to USB devices, 4 pin M12 Coding A <-> USB series B plug, 3 m	22 021 124
Cable to connect Digital I/O option with Relay box, 12 pin M12 <-> open ends, 10 m	22 021 093
<b>I/O accessories</b>	<b>Order no.</b>
Relay box for Digital I/O option	22 011 967
Power supply for Relay box 4 (110–230 VAC)	00 505 544
<b>Adapters *</b>	<b>Order no.</b>
RS232 adapter, 8 pin M12 plug <-> 8 pin Binder receptacle, 0.2 m	22 021 094
RS485 adapter, 6 pin M12 plug <-> 6 pin Binder receptacle, 0.2 m	22 021 095
Ethernet adapter, 4 pin Coding D M12 plug <-> 16 pin Binder receptacle, 0.2 m	22 021 096
USB adapter, 4 pin Coding A M12 plug <-> 16 pin Binder receptacle, 0.2 m	22 021 097
Digital I/O adapter, 12 pin M12 plug <-> 19 pin Binder receptacle, 0.2 m	22 021 098

\* Use already installed cables/plugs with our new ICS6x9 M12 plug

<b>Mechanical parts</b>	<b>Order no.</b>
Protective cover for terminals ICS6x9, set of 3 pieces	22 021 110
Stand ICS6x9, height 50 mm	22 018 057
Stand ICS6x9, for PBA430 weighing platform height 330 mm height 660 mm	22 013 964 22 013 965
Stand ICS6x9 for KA, KB, MA, MB and DB platforms, height 330 mm	22 014 836
Bench stand ICS6x9 for scale bench 00503632 or 00504854, height 500 mm	22 014 835
Floor stand ICS6x9, height 1000 mm	22 014 834
Standbase for floor stand	22 011 982
Wall bracket ICS6x9, inclinable and swivelling	22 014 833
Desk mounting plate, for terminal and .../t version only	22 021 111

## 8 Appendix

### 8.1 Tests for utilisation in hygienically sensitive areas

ICS649-check weighing terminals have been assessed by the EHEDG (European Hygienic Engineering and Design Group) and the NSF (National Sanitation Foundation). Both institutes certify the fulfilment of the hygienic requirements for easy cleaning (Hygienic Design Criteria).

**EHEDG** The EHEDG is an association of device manufacturers, firms in the foodstuff industry, research institutes and health authorities. It was founded in 1989 with the aim of promoting the hygienically faultless manufacturing and packaging of foodstuffs. A positive expertise of the device by the EHEDG has taken place. A corresponding report is available on the internet under [www.mt.com](http://www.mt.com).

**NSF** NSF is an independent NGO founded in 1944 in the USA. Corresponding regulations were published for the use of devices in the foodstuff industry. The device fulfils the NSF criteria C-2 (Special Equipment and/or Devices) for use in the foodstuff industry. The products are listed on the NSF site: [www.nsf.org](http://www.nsf.org).

### 8.2 Notice for verified instruments in EC countries



Weighing instruments verified at the place of manufacture bear the preceding mark on the packing label and a green "M" sticker on the descriptive plate. They may be set to work immediately.



Weighing instruments which are verified in two steps have no green "M" on the descriptive plate and bear the preceding identification mark on the packing label. The second step of the verification must be carried out by the approved METTLER TOLEDO service or Weights and Measures authorities. Please contact your METTLER TOLEDO organisation. The first step of the verification has been carried out at the manufacturing plant.

If national regulations in individual countries limit the period of validity of the verification, the operator of such a weighing instrument is himself responsible for its timely re-verification.

### 8.3 Tables of Geo Code values

For weighing instruments verified at the manufacturer's, the Geo Code value indicates the country or geographical zone for which the instrument is verified. The Geo Code value set in the instrument (e.g. "Geo 18") appears briefly after switching on.

Table "Geo Code values 3000e" shows the Geo Code values for European countries.

Table "Geo Code values 6000e/7500e" shows the Geo Code values for different gravitation zones.

#### 8.3.1 Geo Code values 3000e, OIML Class III (European Countries)

Country	Geographical latitude	Geo Code value
Austria	46°22' – 49°01'	18
Belgium	49°30' – 51°30'	21
Bulgaria	41°41' – 44°13'	16
Croatia	42°24' – 46°32'	18
Czechia	48°34' – 51°03'	20
Denmark	54°34' – 57°45'	23
Estonia	57°30' – 59°40'	24
Finland	59°48' – 64°00'	25*
	64°00' – 70°05'	26
France	41°20' – 45°00'	17
	45°00' – 51°00'	19*
Germany	47°00' – 55°00'	20
Greece	34°48' – 41°45'	15
Hungary	45°45' – 48°35'	19
Iceland	63°17' – 67°09'	26
Ireland	51°05' – 55°05'	22
Italy	35°47' – 47°05'	17
Latvia	55°30' – 58°04'	23

Country	Geographical latitude	Geo Code value
Liechtenstein	47°03' – 47°14'	18
Lithuania	53°54' – 56°24'	22
Luxemburg	49°27' – 50°11'	20
Netherlands	50°46' – 53°32'	21
Norway	57°57' – 64°00'	24*
	64°00' – 71°11'	26
Poland	49°00' – 54°30'	21
Portugal	36°58' – 42°10'	15
Romania	43°37' – 48°15'	18
Slovakia	47°44' – 49°46'	19
Slovenia	45°26' – 46°35'	18
Spain	36°00' – 43°47'	15
Sweden	55°20' – 62°00'	24*
	62°00' – 69°04'	26
Switzerland	45°49' – 47°49'	18
Turkey	35°51' – 42°06'	16
United Kingdom	49°00' – 55°00'	21*
	55°00' – 62°00'	23

\* factory setting

## 8.3.2

## Geo Code values 6000e/75000e OIML Class III (Height ≤ 1000 m)

Geographical latitude	Geo Code value	Geographical latitude	Geo Code value
00°00' – 12°44'	18	43°26' – 47°51'	18
05°46' – 17°10'	21	45°38' – 50°06'	22
12°44' – 20°45'	16	47°51' – 52°22'	20
17°10' – 23°54'	18	50°06' – 54°41'	21
20°45' – 26°45'	20	52°22' – 57°04'	24*, 26
23°54' – 29°25'	23	54°41' – 59°32'	21
26°45' – 31°56'	24	57°04' – 62°09'	15
29°25' – 34°21'	25*, 26	59°32' – 64°55'	18
31°56' – 36°41'	17, 19*	62°09' – 67°57'	19
34°21' – 38°58'	20	64°55' – 71°21'	18
36°41' – 41°12'	15	67°57' – 75°24'	15
38°58' – 43°26'	19	71°21' – 80°56'	24*, 26
41°12' – 45°38'	26	75°24' – 90°00'	18

\* factory setting

## 8.4



## Disposal

In conformance with the European Directive 2002/96 EC on Waste Electrical and Electronic Equipment (WEEE), this device may not be disposed of with domestic waste. This also applies to countries outside the EU, according to their specific requirements.

Please dispose of this product in accordance with local regulations at the collecting point specified for electrical and electronic equipment.

If you have any questions, please contact the responsible authority or the distributor from which you purchased this device.

Should this device be passed on to other parties (for private or professional use), the content of this regulation must also be related.

Thank you for your contribution to environmental protection.

## 8.5

## Protocol printouts

### GA46 printouts, in English

#### Straight weighing

XXXXXXXXXXXXXXXXXXXXX	Starline
Gross 1.19 kg	Gross/net/tare weights
Net 0.37 kg	
Tare 0.82 kg	New line

#### Average weighing

XXXXXXXXXXXXXXXXXXXXX	Starline
Gross 1.19 kg	Gross/net/tare weights
NetAverage 0.37 kg	
Tare 0.82 kg	New line

#### Printout with header

METTLER TOLEDO	Header
Tel. +49 7431 140	
Germany	New line
www.mt.com	
Date 27/04/2010	Date & time
Time 22:21:14	
Net 0.37 kg	Net/tare weights
Tare 0.82 kg	
	New line
Dev. Id #4591-22.A	Device information
Dev. Loc Building B9	
	New line

#### Printout with header and identification data

METTLER TOLEDO	Header
Tel. +49 7431 140	
Germany	
www.mt.com	
Date 27/04/2010	Date & time
Time 21:50:48	
ID1 Company ABC	Identifications
ID2 67195 Tomn	
Net 0.57 kg	Net/tare/gross weights
Tare 0.82 kg	
Gross 1.39 kg	
	New line

#### Checkweighing (standard printout)

Position Good	Checkweighing result
METTLER TOLEDO	Header
Tel. +49 7431 140	
Germany	
www.mt.com	
Date 07/01/2010	Date & time
Time 23:54:56	
ID1 Company ABC	Identifications
ID2 67195 Tomn	
Net 0.710 kg	Net/tare/gross weights
Tare 0.025 kg	
Gross 0.735 kg	
Target 0.700 kg	Checkweighing parameters
Tol - 0.050 kg	
Tol + 0.090 kg	
Tol.Type Relative	
Dev. 0.010 kg	

#### Checkweighing (pieces)

Position <Tolerance	Checkweighing result
METTLER TOLEDO	Header
Tel. +49 7431 140	
Germany	
www.mt.com	
Date 08/01/2010	Date & time
Time 00:02:53	
ID1 Company ABC	Identifications
ID2 67195 Tomn	
Gross 2.090 kg	Weight
Target 90 PCS	Checkweighing parameters
Tol - 1 PCS	
Tol + 1 PCS	
Tol.Type Relative	
Dev. -3 PCS	

#### Checkweighing (minimum printout)

Position >Tolerance	Checkweighing result
Net 0.925 kg	Net weight

#### Piece counting

Date 08/01/2010	Date & time
Time 00:06:31	
Net 0.700 kg	Net weight/quantity
Quantity 29 PCS	
APH 23.96766 g	Average piece weight

## 8.6 Index

- A**
- Accessories ..... 89
  - Alibi log ..... 17, 55, 76
  - Alphanumeric entry ..... 15
  - Average weighing ..... 27, 53
- B**
- Barcode
    - Destination ..... 67
    - Identification ..... 29
    - Tare preset ..... 24
  - Battery
    - Handling ..... 19
    - Specification ..... 82
  - Beeper ..... 61
- C**
- Calendar ..... 60
  - Calibration log ..... 17
  - Cleaning ..... 30
  - Commissioning ..... 18
  - Connections ..... 15
- D**
- Date ..... 60
  - Display
    - Backlighting ..... 59
    - Brightness ..... 59
    - Contrast ..... 59
    - Metrological data ..... 11
    - Over/Under Checkweighing . 9, 10
    - Presentation in the menu ... 44
    - Symbols and info line ..... 12
    - Weight display ..... 11
  - Disposal ..... 94
  - Dynamic weighing ..... 27, 53
- E**
- Environment ..... 30, 82
  - Errors ..... 78
    - Error conditions ..... 78
    - Error messages ..... 79
- G**
- Geo value ..... 21, 32, 93
- I**
- Identifications ..... 29, 70
  - Info key ..... 29
  - Information ..... 80
  - Interface settings ..... 62
    - Digital I/O ..... 68
    - Ethernet ..... 69
    - RS232 ..... 64
    - RS422 / RS485 ..... 64
    - USB ..... 69
    - WLAN ..... 70
- K**
- Keyboard ..... 13
  - Key lock ..... 60
- L**
- Log files
    - Alibi log file ..... 76
    - Routine test log file ..... 75, 76
  - Login/logout ..... 21
- M**
- Menu
    - Access ..... 61
    - Application ..... 52
    - Communication ..... 62
    - Maintenance ..... 71
    - Operation ..... 43
    - Password ..... 43, 61
    - Quick Select ..... 73
    - Scale (analog) ..... 46
    - Scale (IDNet) ..... 49
    - Terminal ..... 56
  - Messages ..... 78
  - MinWeigh ..... 49, 51
  - Mode
    - Demand mode ..... 65
    - Dialog mode ..... 65
    - Print mode ..... 65
- P**
- MT continuous ..... 62
  - Options ..... 7, 86
  - Output mode ..... 69
  - Over/Under Checkweighing 10, 33
    - Checkcounting ..... 35
    - Display ..... 36
    - Quick start ..... 39
    - Stored target values ..... 35
    - Subtractive weighing ..... 38
    - Take-away mode ..... 40
    - Tolerance types ..... 33
    - To zero ..... 41
  - Piece counting ..... 27
  - Power off ..... 58
  - Power supply ..... 19, 82
  - Printing ..... 24
  - Printout
    - Examples ..... 95
    - Templates ..... 70
- Q**
- Quick Select
    - Alibi log file ..... 76
    - Enter main menu ..... 73
    - Logout ..... 73
    - Routine test ..... 74, 75, 76
- R**
- Routine test ..... 17, 74, 75, 55
- S**
- Safety instructions ..... 5, 31
  - Setpoints ..... 68
  - SICS
    - Command set ..... 62
    - Identifications ..... 29
    - Tare preset ..... 24
  - Simple weighing ..... 22
  - Sleep mode ..... 58



Smart weighing counter .....	81
Soft keys .....	14
Spanner icon .....	9, 81
Switching on and off.....	21

## **T**

Tare	
Automatic clearing	23, 48, 50
Automatic taring ...	23, 48, 50
Chain tare .....	23, 48, 50
Tare preset .....	24
Taring .....	22
Technical data	
Weighing platforms .....	85
Weighing terminal.....	82
Terminal and platform	
combinations .....	6, 85
Test	
Display .....	71
Keyboard .....	71
Scale.....	71
Verification .....	32
Time .....	60
Totalising .....	25, 55

## **U**

User management.....	16, 61
----------------------	--------

## **V**

Verified instruments in EC	
countries.....	92

## **W**

Warnings .....	79
----------------	----

## **Z**

Zero	
Automatic zero update.	48, 50
Zeroing .....	22
Zero point correction.....	22

**To protect your METTLER TOLEDO  
product's future:**

METTLER TOLEDO Service XXL assures  
the quality, measuring accuracy and  
preservation of value of all METTLER  
TOLEDO products for years to come.

Please send for full details about our  
attractive terms of service.

Thank you.

[www.mt.com/service](http://www.mt.com/service)

For more information

**Mettler-Toledo (Albstadt) GmbH**

D-72458 Albstadt

Tel. +49 7431-14 0

Fax +49 7431-14 232

Subject to technical changes

© 11/2010 Mettler-Toledo (Albstadt) GmbH

Printed in Germany

Order number 22021156A



\* 2 2 0 2 1 1 5 6 A \*