

Compact Weighing Systems



Industrial Compact Systems

- Fast and Precise
- Simple to Operate
- Rugged Construction
- Tailored to Your Needs
- Efficient to Clean



Designed to Speed up Production
In Wet & Harsh Environments

METTLER TOLEDO

Optimize Your Production Processes

Meet Your Toughest Requirements

Production operators need to be familiar with their weighing systems. This is an important basic requirement to optimize your production. But how can this be achieved as every working place is different? The new food scale line: ICS429 – ICS439 – ICS449 – ICS469 offers you seamless integration into your production process as your weighing solution will be individually configured for fast and precise operations – exactly according to your needs.

Make your choice and speed up your production process

The ICS bench portable food line is based on four different terminal models. Each of them can be ergonomically mounted in three different ways to the weighing platform. Choose from a broad range of platform sizes and capacities. An optimal combination increases the process security, leads to less production failure and speeds up your productivity.

Ergonomic working procedure preferred

To optimize your process procedure, you choose the placement of your terminal for best ergonomic position. Either fixed directly on the platform, mounted on a column or separated for desk or wall mounting.

Designed for fast and efficient cleaning

The whole product family is built according to the latest international hygienic guidelines. The open stainless steel construction mini-

mizes contamination traps and provides easy access to all parts for fast and efficient cleaning. The total hygienic design of the product line will assist your HACCP plan compliance efforts.

Seamless data integration

Scales are important identification points in your traceability process. Various interface options offer easy integration into existing data management systems. External devices such as printers, barcode readers and labeling equipment can easily be integrated.



Column – ICS4_9...c

Weighing terminal and column are seamlessly welded together, the back column design secures and protects cables



Compact – ICS4_9...f

Terminal fix mounted in front of the weighing platform. One unit, portable and robust



Separate – ICS4_9...t

Suitable for wall mount, bench or desk operation. The ICS stand-alone terminal can be easily used and integrated with any other platform including floor scales.

Everything you need to know:
Sharp, clear and easy to read

Basic Weighing and Checkweighing – configurable terminals show exactly what you need to know. Selectable language options further increase your operator’s ease of use and ultimately improve your process speed and productivity.

All four terminal models guarantee a simple and straight forward weighing process. The large display facilitates clear and comfortable data reading. Due to the three selectable modes different parameters are shown, even the display brightness is configurable. A high reading precision to speed up your production.



Terminal IP69k protected
Longer up times in harsh environments. No need for terminal “double bagging” or to distance terminal from the base.



colorWeight®

Accelerated Over/Under Checkweighing



Above tolerance



Within tolerance



Below tolerance

colorWeight® provides clarity – full color graphic for unmistakable results

The colored backlight of the LC display provides easily readable unmistakable information as to whether or not the weight is within the tolerance limit. Different colors options can be configured in the set up menu.

Basic Weighing
Fast and precise operation



ICS429, standard display mode

ICS429

All you need for straight forward basic weighing applications. Simple to operate with only 7 keys for fast and stable results. Simple and intuitive.



ICS439, standard display mode

ICS439

Additionally equipped with a numeric keypad for fast and comfortable changing of menu settings and pre-tare values.

Checkweighing
Color code your tolerance thresholds and results



ICS449, big fonts display mode

ICS449

The colorWeight backlight function offers individual color settings to optimize your process and improve productivity. Use the take away function for repeated manual portioning and increase your process accuracy. Piece counting functions included.



ICS469, 3 line display mode

ICS469

Same functions as ICS449, but accelerated data entry with numeric keypad. Both terminals have the capacity to store up to 50 product records, ready to recall or print.

► www.mt.com/over-under-checkweighers

Resist Wet and Harsh 24/7 for Fast and Complete Washdown

From light wet to harsh conditions: It doesn't matter. The full stainless steel scale platforms provide a flexible and rugged solution for a wide range of weighing tasks. All parts have been built according to the latest hygienic design guidelines supporting an easy, fast and efficient cleaning procedure.



Broad range of weighing platforms

Full stainless steel constructions are available in five different sizes (229x229 mm to 400x500 mm) and five capacities (3 up to 60 kg). Choose your platform.



Made for easy cleaning

The stainless steel construction with smooth surfaces and hygienically designed feet contains no water collecting points and helps to reduce possible bacteria contamination. Built for efficient cleaning.



Rugged, for long life

Optimally placed overload stops provide the best possible protection against load cell damage. Dependable and stable.



The right load cell for an extended life time

Choose the right load cell according to your environment and cleaning procedure. This increases long term life and up-time of your scale and reduces lifetime ownership costs.

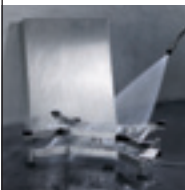

Wet and harsh

The hermetically sealed stainless steel load cell (IP68/IP69k) can withstand not only steam and high pressure wash down, but is also very robust and corrosion resistant.



Part time wet

IP65/IP67 protection with the stainless steel potted load cell to be used in temporary wet and light wash down applications.



Wet wiping or cleaning with low pressure water jets

Providing protection up to IP65 the aluminum potted load cell is suitable for dry and short time wet environment with light hosedown cleaning.

IP69k

Battery operation for high mobility

The optional built-in rechargeable battery allows up to several days of portable use.

Six Steps to Tailor Your Scale

To Your Specific Application/Environment

1 Application / Terminal



Function	Basic Weighing		+/- Checkweighing	
	ICS429...	ICS439...	ICS449...	ICS469...
Key: Power, Clear, Switch weight units	•	•	•	•
Key: Zero, Tare	•	•	•	•
Key: Info	•	•	•	•
Key: Printing / Data transfer	•	•	•	•
Display, LCD with backlighting	•	•	•	•
3 selectable display modes	•	•	•	•
Event and error message	•	•	•	•
Basic weighing	•	•	•	•
Average weighing	•	•	•	•
5 soft keys			•	•
Numeric keypad		•		•
Over/Under Checkweighing				
colorWeight® function			•	•
Backlight color (customizable)			•	•
Over/Under Checkweighing			•	•
Piece counting			•	•
Language				
Display languages: English, German, Spanish, French, Italian, Chinese	•	•	•	•

2 Platform Size



Type	Dimensions	A (mm / ")	BB (mm / ")	B (mm / ")	QA (mm / ")	QB (mm / ")
Separate ICS4_9.../f	a	240 / 9.45	300 / 11.81	400 / 15.74	229 / 9.00	305 / 12.00
	b	300 / 11.81	400 / 15.74	500 / 19.68	229 / 9.00	305 / 12.00
	c	59 / 2.32	76 / 2.99	108.5 / 4.27	59 / 2.32	76 / 2.99
	d	97 / 3.81	108 / 4.25	134.5 / 5.29	97 / 3.81	108 / 4.25
Compact ICS4_9.../f	e	452 / 17.80	549 / 21.61	649 / 25.55	380 / 14.96	452 / 17.80
Column ICS4_9.../c	f	452 / 17.80	515 / 20.28		347 / 13.66	419 / 16.50
	g	386 / 15.20	386 / 15.20		386 / 15.2	386 / 15.20
Terminal	h	232 / 9.13				
	i	132 / 5.20				
	k	115 / 4.53				

3 Capacity & Readability *



Platform Type	3 kg	6 kg / 10 lb	15 kg / 25 lb	30 kg / 50 lb	60 kg / 100 lb
A	1 g	2 g / 0.002 lb	5 g / 0.005 lb		
BB				10 g / 0.01 lb	20 g / 0.02 lb
B				10 g / 0.01 lb	20 g / 0.02 lb
QA	1 g	2 g / 0.002 lb			
QB			5 g / 0.005 lb	10 g / 0.01 lb	20 g / 0.02 lb

4 Load Cell according to Environment / Cleaning

IP Rating	Weighing platform			Terminal
	IP65 Potted aluminum load cell	IP65 & 67 Potted stainless steel load cell	IP68 & 69k Hermetically sealed stainless steel load cell	IP68 & 69k Terminal
Environment				
Short time wet (30 min / day)	•	•	•	•
Part time wet (120 min / day)		•	•	•
Permanent wet			•	•
Cleaning procedure				
Wet wipe down	•	•	•	•
Lighthose down >5l / min, 20 kPa	•	•	•	•
Lightwash down > 12.5l / min, 30 kPa		•	•	•
Heavy wash down, high pressure water and steam jet up to 10000 kPa			•	•

* Approved by Weights & Measures: OIML Class III 3000e, NTEP 5000d, Resolutions up to 15000d not approved by W&M.

5 Accessories

Interfaces, Plugs, Adapters	RS232, RS422, RS485, Ethernet, USB Device, Digital I/O
I/O Accessories	Relay box for digital I/O incl. power supply
Mechanical Parts	Protective cover for terminals, Wall bracket, Desk mounting plate
Stands	In many heights and versions
Others	Printers, interfaces, cables and much more

6 Service

Installation & Setup	Installation, setup, data loading, user training to ensure fast, initial start-up
Qualification	Equipment qualification to meet your local or international quality system requirements
Calibration	Calibration and certification to meet production or regulatory requirements
Preventative Maintenance	On-going maintenance to ensure dependable operation and long equipment life

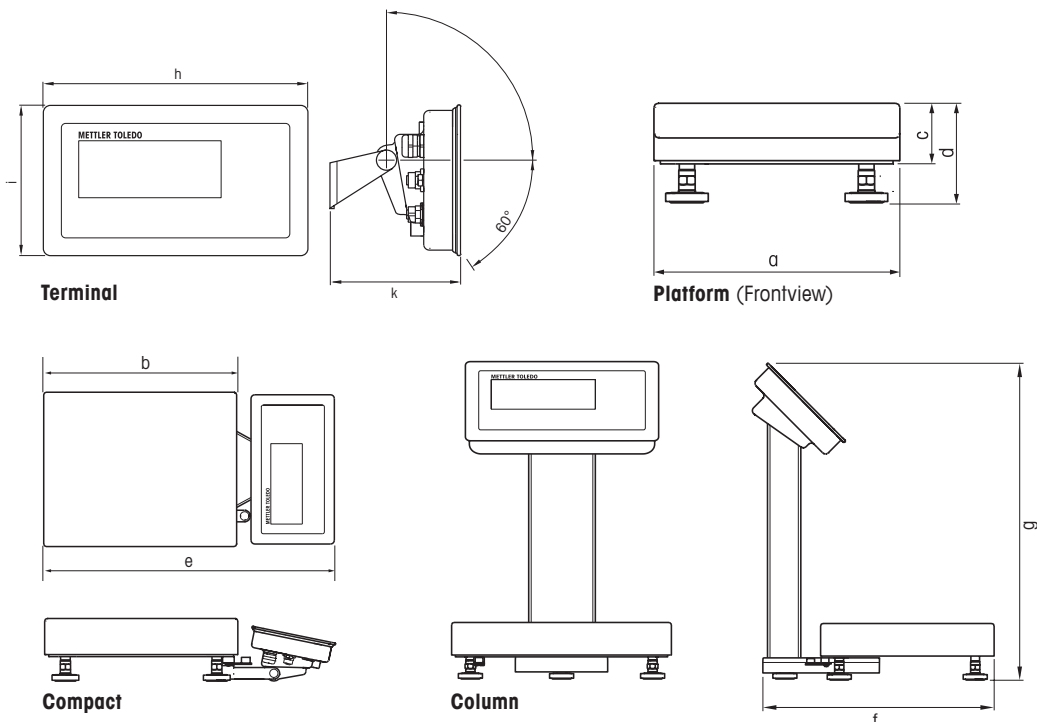

Lifetime Performance – with Precise Service

The right scale choice is the perfect start to meet your requirements. Realizing the results you expect also depends on precise installation, setup, calibration and maintenance, product and service together, delivering performance, security and longevity

Since we designed the scale to be efficiently serviced and then tailor our services to your process and business needs, we help you to realize and sustain accurate, dependable and accountable weighing results, with the productivity you require.

Service	Benefits
Installation & Setup	<ul style="list-style-type: none">• Proper installation for accurate, repeatable weighing results• Communications to peripherals and systems tested• Sequences set to enhance operator productivity• Operational and user maintenance procedures trained• Ensures fast and efficient process start-up
Equipment Qualification	<ul style="list-style-type: none">• Documents that performance meets process requirements• Provides procedures for periodic testing in production• Reduces the risk of non-compliance with regulations
Calibration	<ul style="list-style-type: none">• Tests for accuracy throughout weighing ranges• Accuracy checked at multiple positions on the scale platform• Concise and regulatory compliant calibration certificates• Application of industry and regulatory tolerance standards• Reduce product give-away and/or over-charges• Lower out-of-specification product liability
Preventative Maintenance	<ul style="list-style-type: none">• Check critical components to identify potential failure• Examines audit and error logs to avoid unexpected downtime• Test operation for weighing and application performance• Ensures reliable operation and avoids unexpected expenditures• Increases the longevity of the scale and your return on investment

Our global service organization delivers the following key benefits:

- Properly maintained equipment ensures productivity and optimizes process performance
- Simplified compliance with industry specific standards and regulations
- Clear and precise documentation to reduce the risk of non-compliance

www.mt.com

For more information

Mettler-Toledo AG
CH-8606 Greifensee
Switzerland
Tel. +41 44 944 22 11
Fax +41 44 944 30 60

Product range may vary depending on country
Subject to technical changes
© 01/2011 Mettler-Toledo AG
Printed in Switzerland
MarCom Industrial

MTSI 44099479