

Operating instructions

METTLER TOLEDO MultiRange Application software IND690-Count

METTLER TOLEDO

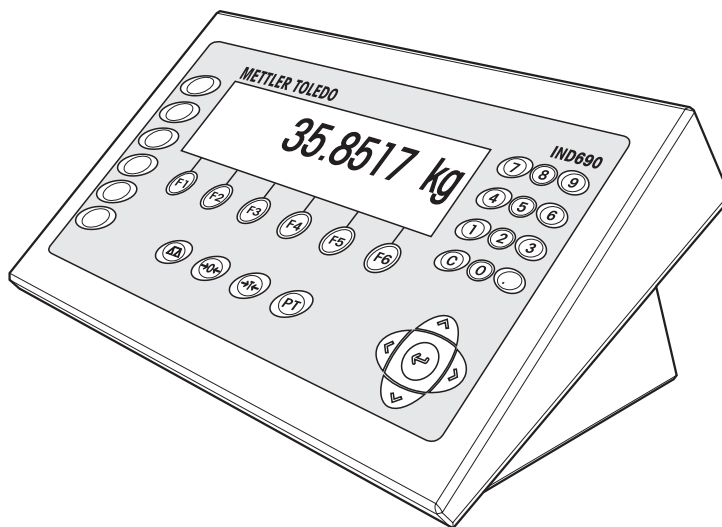
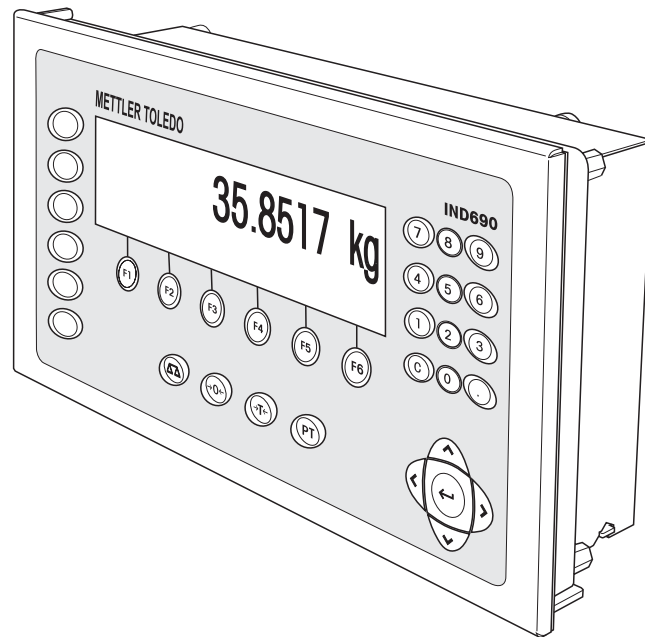

www.mt.com/support

ServiceXXL

Tailored Services

Congratulations on choosing the quality and precision of METTLER TOLEDO. Proper use according to these instructions and regular calibration and maintenance by our factory-trained service team ensure dependable and accurate operation, protecting your investment. Contact us about a ServiceXXL agreement tailored to your needs and budget.

We invite you to register your product at www.mt.com/productregistration so we can contact you about enhancements, updates and important notifications concerning your product.

Contents

	Page
1	Counting functions..... 4
1.1	Documentation 4
1.2	Introduction..... 4
1.3	COUNTING application 4
1.4	PIECE-FILLING application 8
1.5	NEUTRAL MEASUREMENT application..... 15
1.6	Monitoring reference weight 18
1.7	Automatic reference optimization 18
1.8	Statistical evaluation of reference pieces 19
1.9	Counting with the DeltaTrac 20
1.10	Working with several weighing platforms..... 21
1.11	PE balance as reference balance 22
1.12	Recall application-specific information 22
2	Settings in the master mode 23
2.1	Overview of the PAC master mode block..... 23
2.2	Settings in the master mode block PAC..... 24
3	Application blocks 34
4	What to do if ...? 40
5	Technical data 41
6	Appendix 42
6.1	Connection diagram and terminal assignment for 8-690 relay box..... 42
6.2	Connection suggestions for various vibration conveyors 43
7	Index 44

1 Counting functions

1.1 Documentation

The weighing terminal IND690-... comes supplied with a CD containing all the documentation on the weighing system IND690.

These operating instructions describe the operation and configuration of the application software IND690-Count.

The basic information for working with the weighing terminal IND690-... can be found in the operating instructions IND690-Base.

1.2 Introduction

The IND690-Count is equipped with three different counting applications which can be set in the master mode: COUNTING, PIECE-FILLING and NEUTRAL MEASUREMENT. For all applications a reference value is entered prior to counting.

1.3 COUNTING application

After a reference value (pieces or piece weight) is specified, the IND690-Count determines the related number of pieces for the COUNTING application from the measured weight value.

Prerequisite

The COUNTING application is selected in the master mode.

Function keys The function keys for the COUNTING application are assigned as follows:

REF 10	REF N	REF W	PLUS	SUM	← →
Copy standard reference quantity. Factory setting: 10 pieces	Enter variable reference quantity	Enter reference piece weight	Totalize pieces	Display and print total pieces	Switch back and forth between total pieces and pieces of current item

→ Select the function by pressing the function key.

Example

→ Press the REF N key.

Then enter the reference quantity manually with the keypad.

When the function keys are otherwise allocated

→ Press the cursor keys < or > repeatedly until the function key assignment shown above appears.

1.3.1 Specifying reference value

Standard reference quantity

1. Place reference pieces on or remove from the weighing platform in accordance with the standard reference quantity, e.g. 10 pieces (factory setting).
2. Press REF 10 key.
The display shows STD REF 10 PCS and then the current quantity in PCS, here 10 PCS.

Note

The standard reference quantity can be set in the master mode, see section 2.2.

Variable reference quantity

1. Place any number of reference pieces on the weighing platform or remove as many reference pieces from it as desired.
2. Press REF N key.
VAR REF _ PCS appears in display.
3. Enter the quantity in accordance with the reference pieces placed on the weighing platform or removed from it and confirm with ENTER.
As long as no stability is reached, REF DETERMINATION appears in display, then number of reference pieces in PCS.

Entering reference piece weight numerically

1. Press REF W key.
2. Enter the known piece weight of a reference piece in the displayed unit and confirm with ENTER.

Notes

- The weight unit for entering the reference piece weight can be selected with the cursor keys < or >.
- The entry can be corrected one character at a time with the CLEAR key.

Copying reference piece weight constants

1. Enter the number of the reference weight memory: 1 ... 999.
2. Press REF W key.
Display briefly shows piece designation and piece weight from respective memory and then current number of pieces with unit PCS.

Entering article number

If ARTICLE NUMBER ON is selected in the master mode, then the reference weight can be displayed by entering the article number.
If a barcode reader is also connected, then the reference weight can be read in with the barcode reader.

→ Press the CODE A key and enter the article number.

– or –

→ Read in the article number directly with the barcode reader.
Display briefly shows piece designation and piece weight from respective memory and then current number of pieces with unit PCS.

Notes

- If no reference values are stored for the article number, the message NEW ARTICLE appears. The reference weight and name of the article can be entered and stored as new constants.
- If REFERENCE WEIGHT UPDATE ON is selected in the master mode, then the reference weight can be changed after displaying the article.

Monitoring the reference weight

If the display indicates ADD ... PCS or REF WEIGHT TOO LOW, the minimum reference weight is dropped below, see section 1.6.

→ Lay additional reference pieces on the weighing platform and confirm with ENTER.

1.3.2 Delete reference value and end counting application

→ Press REF N or REF W key and delete the reference value with the CLEAR key. The display changes to the normal weight display.

1.3.3 Additive counting

During additive counting a container is filled with a certain content.

1. Place an empty container on the weighing platform and tare the weighing platform.
2. Specify a reference value, see section 1.3.1.
3. Lay pieces on the platform.
The current quantity is displayed in PCS.

1.3.4 Subtractive counting**Without returning**

Pieces are removed from the filled container until the desired quantity is reached. The removed pieces are not laid back on the weighing platform when doing so.

1. Place a filled container on the weighing platform and tare the weighing platform.
2. Specify a reference value, see section 1.3.1.
The removed quantity is displayed with a negative sign.
3. Remove pieces.
The current quantity is displayed in PCS.

With returning

Only the reference pieces are removed from the filled container and returned to the weighing platform. Then count all pieces in the container.

1. Place a filled container on the weighing platform and tare the weighing platform.
2. Specify a reference value, see section 1.3.1.
The removed quantity is displayed with a negative sign.
3. Return the removed reference pieces to the weighing platform.
4. Press TARE SPECIFICATION key, enter the known container weight and confirm with ENTER.
The quantity and total weight of the container content are displayed.

1.3.5 Totalizing

Items of the same piece goods can be totalized as follows:

1. Specify a reference value, see section 1.3.1.
2. Lay 1st item on the weighing platform and press the PLUS key.
The display shows the quantity of the current item.
3. Relieve weighing platform.
4. Lay additional items on the weighing platform consecutively and repeat steps 1 and 2.
The display shows the number of totalized items and the total quantity.
5. To switch back and forth between the total quantity of all items and the quantity of the current item, press the ← → key.
6. Press SUM key.
The total quantity of all items is displayed and printed.
7. To end totalizing, press the SUM, CLEAR key sequence.
The sum is cleared and the item counter is reset.

Notes

- IND690-Count totalizes the gross, net and tare values of the items internally. These sums can be read via the application blocks 315, 316 and 362.
- If CLEARING OF TOTAL ON is set in the master mode, a new reference value cannot be entered until the old sum is cleared. If the sum is not cleared yet, the message CLEARING OF TOTAL appears.

1.4 PIECE-FILLING application

After specification of a reference value, the IND690-Count automatically dispenses a specified quantity for the PIECE-FILLING application.

Prerequisite

The PIECE-FILLING application is selected in the master mode.

Function keys The function keys for the PIECE-FILLING application are assigned as follows:

REF 10	REF N	REF W	PLUS	SUM	LIMIT
Copy standard reference quantity. Factory setting: 10 pieces	Enter variable reference quantity	Enter reference piece weight	Totalize pieces	Display and print total pieces	Enter and print filling parameters

→ Select the function by pressing the function key.

Example

→ Press the REF N key.
Then enter the reference quantity manually with the keypad.

When the function keys are otherwise allocated

→ Press the cursor keys < or > repeatedly until the function key assignment shown above appears.



CAUTION

Danger of injury when pressing keys which start and stop the filling system or control the valves!

→ Before pressing these keys, make sure that no one is in the area of moving system parts.

1.4.1 Filling system

With feed valves or feed chutes controlled with coarse and fine feed, the filling sample is automatically infed up to the specified target quantity.

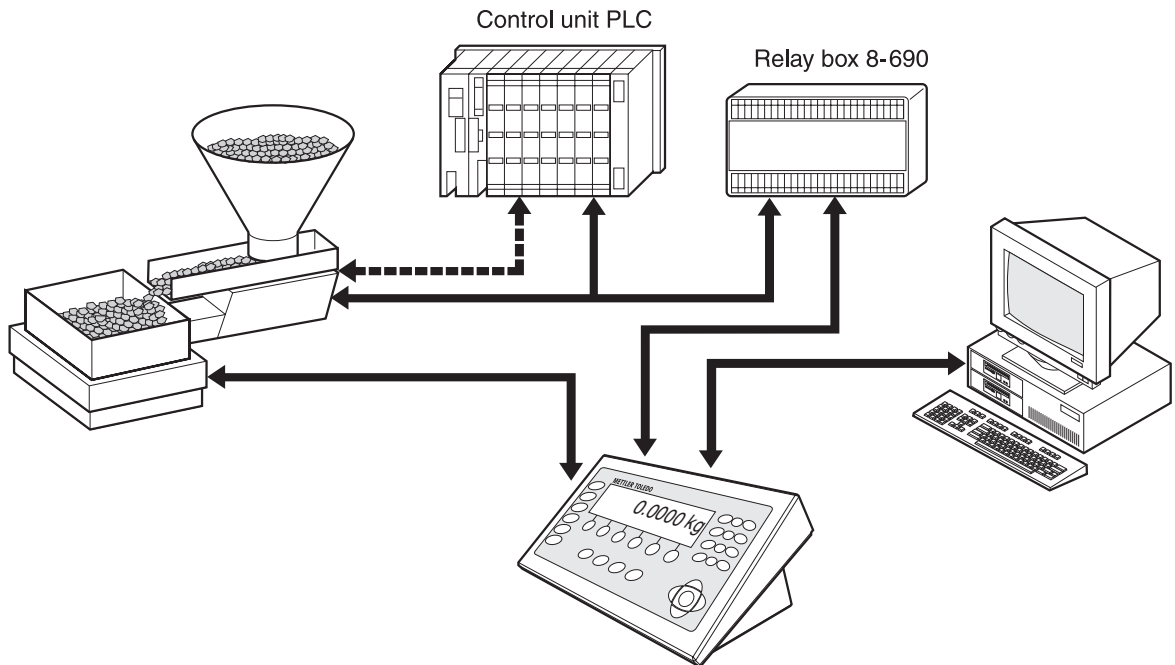

The control signals for the feed valves are transmitted to the 8-690 relay box via the RS485-690 interface. The 8-690 relay box controls the filling system either directly or via an additional external control unit (PLC). In the case of overloading or underloading of the weighing platform, all valves are closed immediately.

1.4.2 Filling process

Filling is carried out in 5 consecutive steps:

- **Automatic tare** – Automatic taring of the container and start of filling
- **Coarse feed** – Filling with coarse feed up to the coarse/fine feed switchover point (Limit 1)
- **Fine feed** – Filling with fine feed up to switch-off point the fine feed (Limit 2)
- **Refill correction** – Refill correction of fine feed beyond Limit 2
- **Refilling** – If the weight value does not lie within the tolerance of the target value at the end of filling, automatic or manual refilling up to the target value

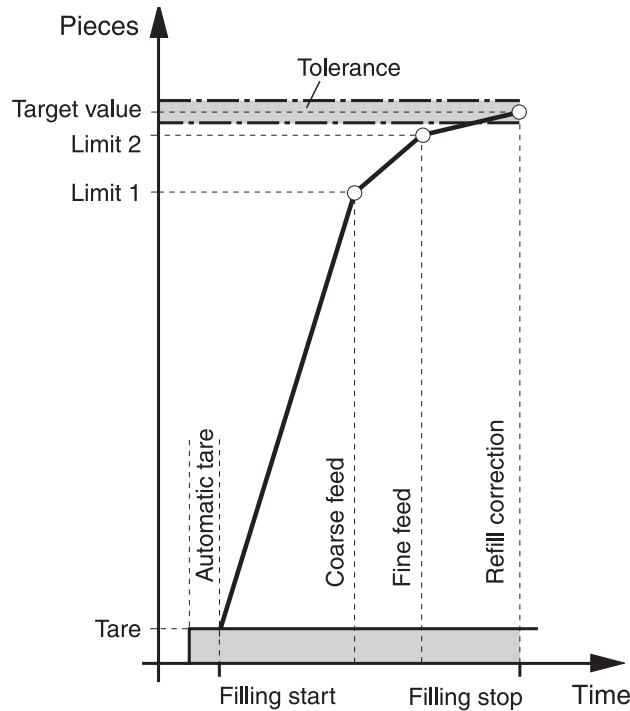

To optimize the filling process, Limit 2 is automatically adjusted with the same component during the next filling process, see REFILL CORRECTION block in section 2.2.1.

If the container is underfilled, automatic or manual refilling can be carried out depending on the settings in the master mode.

Learn mode

If no limits are entered or Limit 1 = Limit 2, the IND690-Count determines the two limits automatically in the learn mode:

The coarse feed is opened by up to half the target value (1) and the refill correction (2) determined. Then the fine feed is switched on (3) and the refill correction (4) determined. Following this, filling is carried out up to the target value (5), (6) and (7).

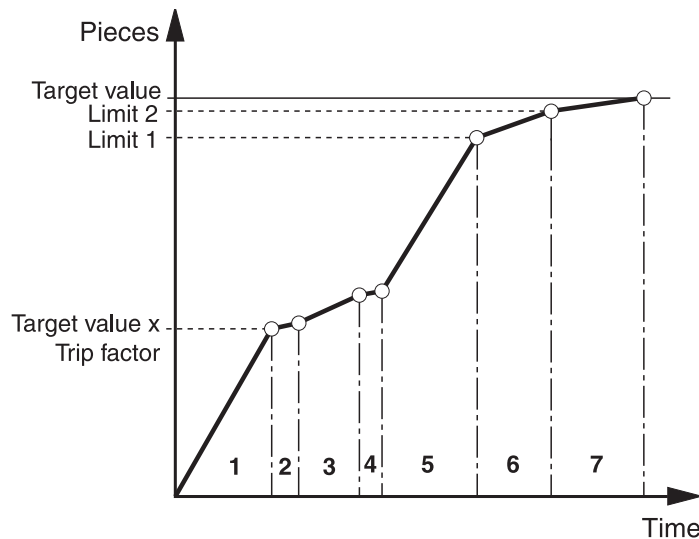

1.4.3 Specifying reference value and dispensing parameters

With fixed target values

Applying fixed target values

1. Enter number of fixed target values: 1 ... 999.
2. Press REF G key.
Display briefly shows piece designation and piece weight, as well as the dispensing parameters from respective memory and then current number of pieces with unit PCS.
The IND690-Count is in the READY FOR DISPENSING state.

Entering article number

If ARTICLE NUMBER ON is selected in the master mode, then the reference weight and dispensing parameters can be displayed by entering the article number.
If a barcode reader is also connected, then the reference weight and dispensing parameters can be read in with the barcode reader.

→ Press the CODE A key and enter the article number.

– or –

- Read in the article number directly with the barcode reader.
Display briefly shows piece designation and piece weight, as well as the dispensing parameters from respective memory and then current number of pieces with unit PCS.
The IND690-Count is in the READY FOR DISPENSING state.

Notes

- If no reference values are stored for the article number, the message NEW ARTICLE appears. The reference weight and name of the article can be entered and stored as new constants.
- If REFERENCE WEIGHT UPDATE ON is selected in the master mode, then the reference weight can be changed after displaying the article.

Manual

1. Specifying reference value

Standard reference quantity

1. Place reference pieces on or remove from the weighing platform in accordance with the standard reference quantity, e.g. 10 pieces (factory setting).
2. Press REF 10 key.
The display shows STD REF 10 PCS and then the current quantity in PCS, here 10 PCS.

Note

The standard reference quantity can be set in the master mode, see section 2.2.

**Variable
reference quantity**

1. Place any number of reference pieces on the weighing platform or remove as many reference pieces from it as desired.
2. Press REF N key.
VAR REF _ PCS appears in display.
3. Enter the quantity in accordance with the reference pieces placed on the weighing platform or removed from it and confirm with ENTER.
As long as no stability is reached, REF DETERMINATION appears in display, then number of reference pieces in PCS.

**Entering reference piece
weight numerically**

1. Press REF W key.
2. Enter the known piece weight of a reference piece in the displayed unit and confirm with ENTER.

Notes

- The weight unit for entering the reference piece weight can be selected with the FUNCTION CHANGE key.
- The entry can be corrected one character at a time with the CLEAR key.

**Monitoring the
reference weight**

If the display indicates ADD ... PCS or REF WEIGHT TOO LOW, the minimum reference weight is dropped below, see section 1.6.

→ Lay additional reference pieces on the weighing platform and confirm with ENTER.

2. Entering dispensing parameters

- Press the LIMIT key and enter the following values:
- Enter the target quantity and confirm with ENTER.
 - Enter limits LIM 1 and LIM 2 and confirm with ENTER.
Without specification the limits are determined automatically.
 - Enter tolerances TOL+ and TOL– and confirm with ENTER.
The display shows READY FOR DISPENSING.

1.4.4 Deleting reference value and end piece-filling application

- Press REF N or REF W key and delete the reference value with the CLEAR key.
The display changes to the normal weight display.

1.4.5 Piece-filling

After entering the filling parameters, the function keys switch over to the following assignment:

START	STOP	CONF	–	TOTAL	LIMIT
Start filling process	Stop filling process	Confirm manual refilling	–	Display and print total quantity	Enter filling parameters and print

The filling type is dependent on the settings in the master mode, see section 2.2.1. Either additive or subtractive weighing is possible.

Additive weighing

With additive weighing a container on the weighing platform is filled from the supply vessel.

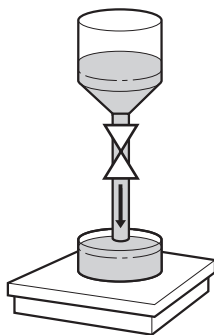

1. Place an empty container on the weighing platform and tare the weighing platform.
2. Press the (external) START key.
The display shows the number of pieces and the filling status (coarse feed ▼▼▼, fine feed ▼).
When the filling process is ended, the display shows whether the weight value lies within the tolerances (CORRECT) or outside (SURPLUS or DEFICIT).
The filling result is printed.
3. Relieve weighing platform.
The display shows READY FOR DISPENSING.

Subtractive weighing

With subtractive weighing a container is filled from the supply vessel on the weighing platform.

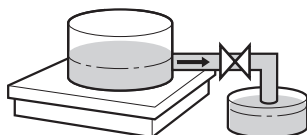

1. Place the filled supply vessel on the weighing platform and tare the weighing platform.
2. Press the (external) START key.
The display shows the number of pieces and the filling status (coarse feed ▼▼▼, fine feed ▼). When the filling process is ended, the display shows whether the weight value lies within the tolerances (CORRECT) or outside (SURPLUS or DEFICIT).
The filling result is printed.
3. Relieve weighing platform.
The display shows READY FOR DISPENSING.

Note

During subtractive weighing the quantity is displayed with a negative sign.

1.4.6 Manual recorection

Prerequisite

REFILLING OFF is set in the master mode, otherwise refilling takes place automatically in the case of underfilling.

1. If the display shows SURPLUS or DEFICIT, correct the quantity manually.
2. If the display shows CONFIRM, press the CONF or external START key.

1.4.7 Interrupting filling process

1. Press the (external) STOP key. The filling process is interrupted.
2. To continue the filling process, press the (external) START key.

1.4.8 Cancelling filling process

→ Press (external) STOP key twice. The filling process is cancelled.

1.4.9 Ending filling process

→ Press (external) STOP key in READY FOR DISPENSING state.
The display changes to the normal weight display.

1.4.10 Totalizing

The AUTO TOTALIZE master mode block (see section 2.2.1) specifies whether totalizing is automatic.

If ITEM COUNTER is used (see section 2.2), the filling system automatically stops when the stop value is reached.

1. Carry out 1st filling process, see section 1.4.5.
2. If AUTO TOTALIZE ON is set in the master mode, the quantity of the current item is added to the sum.
3. Relieve weighing platform.
4. Carry out additional filling processes, see steps 1 to 3.
5. To display and print the total, press the SUM key.
The total quantity is displayed and printed.
6. To carry out filling processes with other piece goods or end totalizing: press the SUM, CLEAR key sequence.

Note

IND690-Count totalizes the gross, net and tare values of the items internally. These sums can be read via the application blocks 315, 316 and 362.

1.5 NEUTRAL MEASUREMENT application

With the NEUTRAL MEASUREMENT application the IND690-Count derives other physical variables, e.g. length, area, volume, from a weight value following specification of a reference value. For example, the length of a cable can be determined from the related weight value.

The unit and format of the physical variable are set in the master mode, see section 2.2.2.

Prerequisite

The NEUTRAL MEASUREMENT application is selected in the master mode.

Function keys In the NEUTRAL MEASUREMENT application the function keys are assigned as follows:

REF 10	REF N	REF W	PLUS	SUM	← →
Copy standard reference variable. Factory setting: 10 units	Enter variable reference variable	Enter reference weight	Totalize variable values (e.g. length)	Display and print total value of the variable (e.g. length)	Switch back and forth between total value of variable (e.g. length) and value of current item

→ Select the function by pressing the function key.

Example

→ Press the REF N key.
Then enter the reference variable manually with the keypad.

When the function keys are otherwise allocated

→ Press the cursor keys < or > repeatedly until the function key assignment shown above appears.

1.5.1 Specify reference value

Standard reference variable

1. Place reference pieces on or remove from the weighing platform in accordance with the standard reference quantity, e.g. 10 pieces (factory setting).
2. Press REF 10 key.
The display shows STD REF 10 PCS and then the current variable with unit, e.g. 10 m.

Note

The standard reference variable can be entered in the master mode under STANDARD REF-PCS, see section 2.2.

Variable reference variable

1. Place reference pieces of any known variable (e.g. 1.25 m long cable) on or remove from the weighing platform.
2. Press REF N key.
3. Enter the variable in accordance with the reference piece (here 1.25) and confirm with ENTER.
The display shows VAR REF and then the current variable with unit (here 1.25 m).

Entering reference piece weight numerically

1. Press REF W key.
2. Enter the known piece weight of a reference piece (e.g. 1 m long cable) in the displayed weight unit and confirm with ENTER.

Notes

- The weight unit for entering the reference piece weight can be selected with the < or > cursor key.
- The entry can be corrected one character at a time with the CLEAR key.

Copying reference piece weight constants

1. Enter the number of the reference weight memory: 1 ... 999.
2. Press REF W key.
The display shows the piece weight from the respective memory.

Entering article number

If ARTICLE NUMBER ON is selected in the master mode, then the reference weight can be displayed by entering the article number.

If a barcode reader is also connected, then the reference weight can be read in with the barcode reader.

→ Press the CODE A key and enter the article number.

– or –

→ Read in the article number directly with the barcode reader.

Display briefly shows piece designation and piece weight from respective memory and then current variable with unit.

Notes

- If no reference values are stored for the article number, the message NEW ARTICLE appears. The reference weight and name of the article can be entered and stored as new constants.
- If REFERENCE WEIGHT UPDATE ON is selected in the master mode, then the reference weight can be changed after displaying the article.

Monitoring the reference weight

If the display indicates ADD ... or REF WEIGHT TOO LOW, the minimum reference weight is dropped below, see section 1.6.

→ Lay additional reference pieces on the weighing platform and confirm with ENTER.

1.5.2 Deleting reference value or end NEUTRAL MEASUREMENT application

→ Press the REF N or REF W key and delete the reference variable with the CLEAR key.

The display changes to the normal weight display.

1.5.3 Neutral measurement

With neutral measurement a container is filled with a certain content.

1. Place an empty container on the weighing platform and tare the weighing platform.
2. Specify a reference value, see section 1.4.3.
3. Lay the weighing sample on the weighing platform.
The variable value (e.g. length) is displayed with unit (max. 3 characters).

1.5.4 Totalizing

Items of the same material can be totalized as follows:

1. Specify a reference value, see section 1.4.3.
2. Place the 1st item on the weighing platform and press the PLUS key.
The display shows the value of the physical variable (e.g. length) with unit, e.g. 1.25 m.
3. Relieve weighing platform.
4. Lay additional items on the weighing platform consecutively and repeat steps 1 and 2.
The display shows the number of totalized items and the total value of the variable, e.g. 6.71 m.
5. To switch back and forth between the total value of all items and the value of the current item, press the ← → key.
6. Press key SUM.
The total value of the variable (e.g. length) is displayed and printed.
7. To end totalizing, press the SUM, CLEAR key sequence.
The sum is cleared and the item counter is reset.

Notes

- IND690-Count totalizes the gross, net and tare values of the items internally. These sums can be read via the application blocks 315, 316 and 362.
- If CLEARING OF TOTAL ON is set in the master mode, a new reference value cannot be entered until the old sum is cleared. If the sum is not cleared yet, the message CLEARING OF TOTAL appears.

1.6 Monitoring reference weight

The IND690-Count checks whether the total weight of the reference pieces is less than a minimum reference weight. If the minimum reference weight is dropped below, the display shows a message dependent on the settings in the master mode.

ADD MODE ON

If the minimum reference weight is dropped below and ADD MODE ON is set in the master mode, the display shows ADD ... PCS or ADD

→ Place additional reference pieces on the weighing platform and confirm with ENTER.

The display shows REF DETERMINATION and then the current quantity or variable.

– or –

→ To count with the original reference quantity, press the REF N key again.

The display shows the quantity or variable with an asterisk:

* ... PCS or * ...

ADD MODE OFF

If the minimum reference weight is dropped below and ADD MODE OFF is set in the master mode, the display shows the quantity or variable with an asterisk: * ... PCS or * ...

Note

If the reference weight placed on the platform is less than 10 % of the minimum reference weight, the display shows REF WEIGHT TOO LOW.

→ Place additional reference pieces on the weighing platform and determine the reference value again.

1.7 Automatic reference optimization

The larger the reference quantity or the reference variable is, the more exactly the IND690-Count determines the quantity or the physical variable (e.g. length) from it. If REF. OPTIMIZATION ON is set in the master mode, the counting accuracy can be improved. Here the following should be observed:

- The displayed and the actual reference quantity or reference variable must match.
- The new reference quantity or reference variable may be a maximum of twice as large as the stored quantity.
- The entire weight of the reference parts may not exceed the upper limit specified in the master mode; factory setting: 4 %.

→ Increase the displayed reference quantity or reference variable by placing additional reference pieces on the platform.

The display shows REF. OPTIMIZATION and then the new reference quantity or reference variable.

1.8 Statistical evaluation of reference pieces

The weight of apparently identical reference pieces is subject to a smaller or larger deviation on which the counting accuracy is dependent.

The IND690-Count determines the mean value, standard deviation, minimum and maximum, and the number of reference pieces for the piece weight of the reference pieces, see application block 392 ... 396 in section 3. Here the following should be observed:

- Use the weighing platform with the highest resolution.
 - The piece weights must be greater than 1 digit.
1. Place an empty container on the weighing platform.
 2. Press the REF W key, enter a piece weight of 0 and confirm with ENTER.
The container is automatically tared and the statistics function started.
 3. When the display shows LOAD SAMPLE 1, place the first reference piece on the weighing platform.
The piece weight is copied and tared away.
 4. When the display shows LOAD SAMPLE X, place additional reference pieces on the weighing platform.
If the piece weight deviates from the previous mean value by more than 50 %, the display shows WRONG SAMPLE.
The piece weight is copied and tared away in each case.
 5. To end the statistical evaluation: press the ENTER key.
The display shows the quantity or the variable (e.g. length) of the reference pieces and copies this value as the reference value for the next counting process.

Note

The statistical evaluation can be cancelled with the CLEAR key.

1.9 Counting with the DeltaTrac

The DeltaTrac is an analog display which simplifies reading off, see "Additional functions" section of the operating instructions for the IND690-Base weighing terminal. Instead of a target weight, a target quantity or the target value of a physical variable is specified for counting.

Limits The following limits apply for the DeltaTrac applications FILLING and CLASSIFYING:

- Minimum value: 10 PCS or 10
- Maximum value: 1'000'000 PCS or 1'000'000
- Minimum tolerance: 1 PCS or 1
- Maximum tolerance:
 - 10 % for the DeltaTrac application FILLING,
 - 50 % for the DeltaTrac application CLASSIFYING,
 - there are no limits for the DeltaTrac application CHECKWEIGHING.

Notes

- DeltaTrac target values cannot be entered until the reference value has been determined.
- The display shows ignored limits, e.g. MIN-DEL = ... PCS, when the target quantity entered was too small.
- When starting a new counting process, the target quantity or the target value is automatically deleted.

1.10 Working with several weighing platforms

When several weighing platforms are connected to the IND690-Count, the reference pieces can be weighed on a reference weighing platform with a higher resolution and the weighing sample counted on a different quantity weighing platform. In the process, the IND690-Count automatically switches back and forth between the two weighing platforms.

In the master mode a preferred reference weighing platform can be selected. The weighing platform with the highest resolution is considered the preferred reference weighing platform in the default configuration, see section 2.2.

1.10.1 Counting with (preferred) reference weighing platform and quantity weighing platform

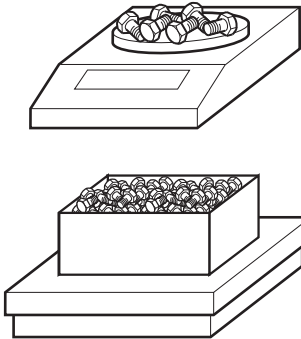

1. Place reference pieces on the (preferred) reference weighing platform with a higher resolution.
2. Press the REF 10 or REF N key.
The reference weight is automatically determined on the (preferred) reference weighing platform.
Then the IND690-Count automatically switches over to the quantity weighing platform last selected.
3. Place the weighing sample on the quantity weighing platform last selected for counting.

1.10.2 Counting only on reference weighing platform

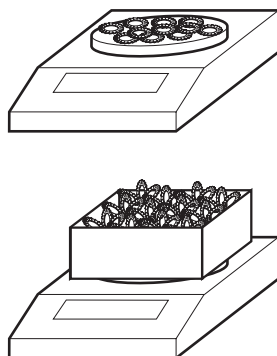

If small pieces in small quantities must be counted, it is advisable to carry out reference determination and weighing on the reference weighing platform.

1. Select the reference weighing platform, see operating instructions for the IND690-Base weighing terminal.
2. Place reference pieces on the (preferred) reference weighing platform with a higher resolution.
3. Press the REF 10 or REF N key.
The reference weight is automatically determined on the (preferred) reference weighing platform.
4. Count the weighing sample on the (preferred) reference weighing platform.

1.10.3 Counting only on quantity weighing platform

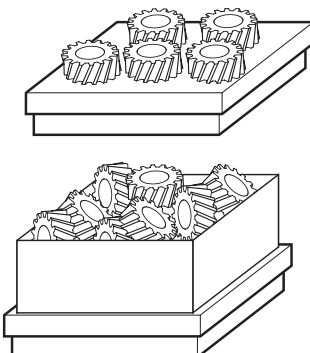

If large pieces must be counted, it is advisable to carry out reference determination and weighing on the quantity weighing platform.

1. Place reference pieces on the quantity weighing platform.
2. Enter the weighing platform number of the quantity weighing platform and press the REF 10 or REF N key.
The reference weight is determined on the quantity weighing platform.
3. Count the weighing sample on the quantity weighing platform.

1.11 PE balance as reference balance

Conditions

- Interface CL20mA-690 installed on IND690-Count in setting transmission and reception loop active.
- Following settings in master mode block CL20mA apply to affected interface CL20mA-690:
 - Communication 7 bits, parity even, 2 stop bits, 2400 baud
 - Dialog mode ON
 - PE send continuous ON
- PE balance connected with connection cable AWG Option and PE/CL Adapter 22 003 029.

Notes on operation

- PE balance cannot be selected as a quantity scale. It can only be operated as a reference scale.
- If a PE balance is connected, it is automatically the preferred reference balance, regardless of which preferred reference scale is set in master mode.
- Reference optimisation, statistic function and ADD mode are not possible with PE balance; lowest counting limit is 1 d.
- Only one PE balance can be connected.

1.12 Recall application-specific information

Information for counting can be recalled with the following key combinations:

INFO, REF 10	Standard reference quantity or standard reference variable
INFO, REF N	Variable reference quantity or variable reference variable
INFO, REF W	Current reference weight
INFO, No., REF W	Reference weight memory No. XXX
INFO, SUM	Current sum
INFO, LIMIT	Current filling parameters for the PIECE-FILLING application
INFO, No., LIMIT	Limit memory No. XXX for the PIECE-FILLING application

Note

If several pieces of information are recalled with one key, the display changes automatically after the set DISPLAY DURATION. You can also switch back and forth between these pieces of information with the CLEAR key.

2 Settings in the master mode

2.1 Overview of the PAC master mode block

In the PAC master mode block the following system settings can be carried out:

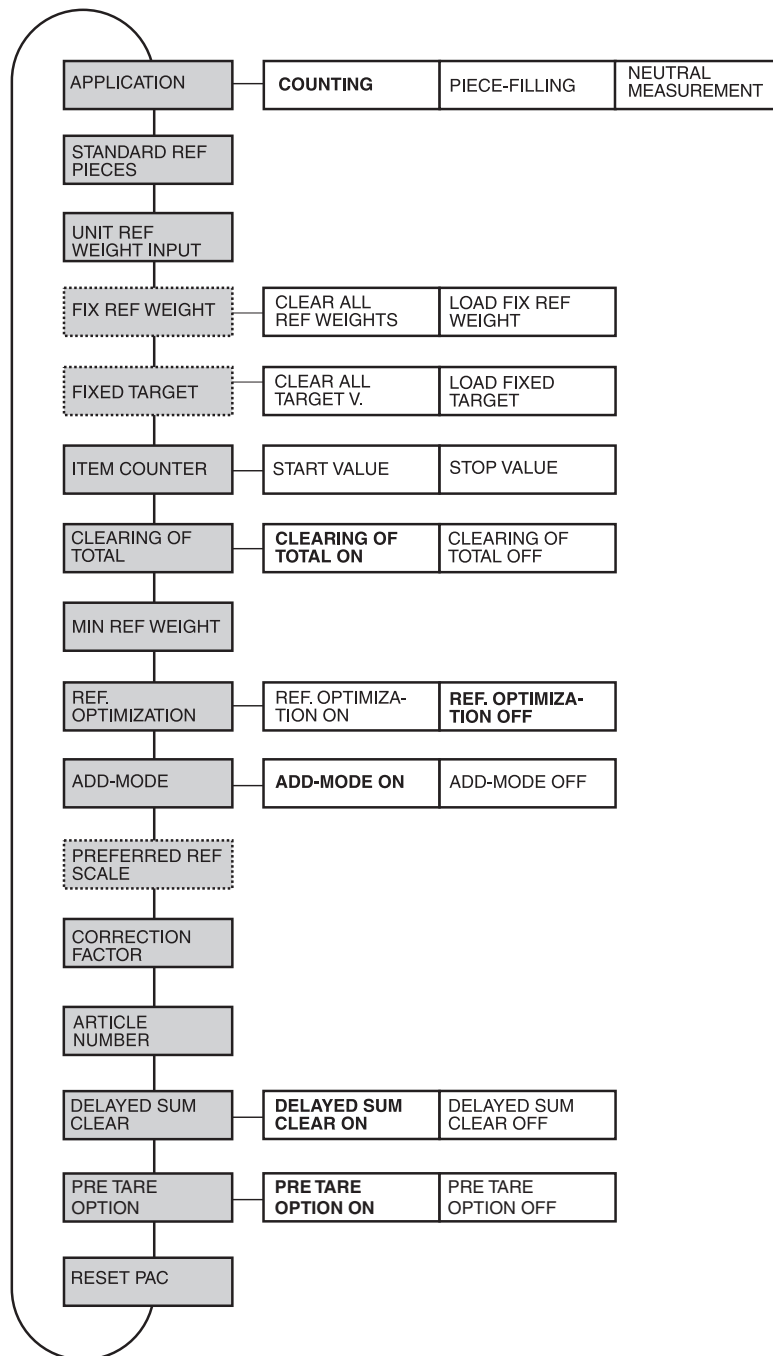

- Legend**
- Blocks on a **grey** background are described in detail in the following.
 - Factory settings are shown in **bold** print.
 - Blocks which only appear under certain conditions have a **dotted outline**.

2.2 Settings in the master mode block PAC

Note

You can make all master mode adjustments conveniently with the PC using the CountTool software. Ask your METTLER TOLEDO sales partner. See section 2.2.3 for examples.

APPLICATION	Select application
COUNTING	Normal counting (factory setting).
PIECE-FILLING	Automatic filling of a specified target quantity; for additional settings see section 2.2.1.
NEUTRAL MEASUREMENT	Derive other physical variables from the weight value, e. g. length, area, volume; for additional settings see section 2.2.2.

STANDARD REF PIECES	Enter standard reference quantity or standard reference variable
STD REF	Possible values: 1 ... 9999 (factory setting: 10), in the application NEUTRAL MEASUREMENT max. 8 characters including decimal point (e.g. 999.9999)
Comments	<ul style="list-style-type: none"> The STD REF is specified in PCS for the COUNTING and PIECE-FILLING applications. The data format and unit are specified in the master mode for the NEUTRAL MEASUREMENT application, see section 2.2.2.

UNIT REF WEIGHT INPUT	Select the preferred unit for the reference weight
UNIT	Possible units: mg, g, kg, lb, ozt, oz. Factory setting: g for 1st weight unit kg, oz for 1st weight unit lb.

FIX REF WEIGHT	Save fixed reference piece weights in the reference piece weight memories
	Only for the applications COUNTING and NEUTRAL MEASUREMENT.
LOAD FIX REF WEIGHT	The contents of the reference-piece weight memories (001 ... 999) are displayed clearly laid out on a display page for each memory number. The reference piece weights can be entered with the function keys and the numeric keypad. For the function key assignment, see the next page.
CLEAR ALL REF WEIGHTS	Clear all reference piece weight memories.

Parameters The following parameters are shown in the display for LOAD FIX REF WEIGHT (example):

REF017:	2 g
NAME:	M8 BOLT
ART #:	123456
TARA:	250 g

REF017: 2 g Reference piece weight for memory number 017, here 2 grams
 NAME: Article name, alphanumeric, max. 20 characters, here M8 BOLT
 ART #: Article number, alphanumeric, max. 20 characters, here 123456

FIXED TARGET	Save fixed target values for piece-filling in the target memories
	Only for the PIECE-FILLING application.
LOAD FIXED TARGET	The contents of the target memories (001 ... 999) are displayed clearly laid out on a display page for each memory number. The dispensing parameters can be entered with the function keys and the numeric keypad. For the function key assignment, see the next page.
CLEAR ALL TARGET V.	Clear all target memories.

Parameters The following parameters are shown in the display for LOAD FIXED TARGET (example):

REF017:	2 g	(M8 BOLT)
S :	2500 PIECES	A #: 123456
L1 :	2000 PIECES	T- : 5 PIECES
L2 :	2400 PIECES	T+ :10 PIECES

REF017: 2 g Reference piece weight for memory number 017, here 2 grams
 S Target pieces, here 2500 pieces
 (...) Article name, alphanumeric, max. 20 characters, here M8 BOLT
 A #: Article number, alphanumeric, max. 20 characters, here 123456
 L1 Switchover point for coarse/fine feed (Limit 1), here 2000 pieces
 If Limit 1 is to be automatically determined in learn mode:
 no entry
 L2 Switch-off point for fine feed (Limit 2), here 2400 pieces
 LIMIT 1 < LIMIT 2.
 If Limit 1 and Limit 2 are to be determined in learn mode:
 no entry
 TOL- Negative tolerance, here 5 pieces
 TOL+ Positive tolerance, here 10 pieces

Function keys The function keys are assigned as follows for LOAD FIX REF WEIGHT and LOAD FIXED TARGET:

↓↑	<	>	F▶	EDIT	↑
Select parameters	Display previous memory	Scroll through memory numbers: Increasing	Select assignment of function key F5	EDIT GO DEL	Return to higher level

EDIT Changes to input mode for marked parameters.

GO Opens desired memory.

DEL Deletes memory.

ITEM COUNTER	Enter item counter for all items which will be added with the PLUS key
START VALUE	Possible values: 1 ... 9999 (factory setting: 1)
STOP VALUE	Possible values: 1 ... 9999 (factory setting: 9999)

CLEARING OF TOTAL	Switch automatic clearing of the sums on or off when starting a new counting process
	Factory setting: CLEARING OF TOTAL ON

MIN REF WEIGHT	Set minimum reference weight
	Factory setting: second-smallest permissible value
MIN W X	Increase the minimum reference weight of the weighing platform X in the displayed unit by the factor 10, 20, 50 or 100.

REF. OPTIMIZATION	Switch automatic reference optimization on or off
	If REF. OPTIMIZATION ON is set, the counting accuracy can be increased by placing additional reference pieces on the scale. The new reference quantity or reference variable may be a maximum of twice as large as the quantity/variable last saved. Factory setting: REF. OPTIMIZATION OFF.
MAX. LIMIT	Enter the upper limit in % of the maximum load of the weighing platform up to which optimisation is to be carried out. Possible settings: 1 ... 100 % Factory setting: 4 %

ADD-MODE	Switch the add-mode on or off
	<p>If ADD-MODE ON is set, the weight of all reference pieces is compared to the minimum reference weight and the missing quantity is determined.</p> <ul style="list-style-type: none"> • ADD-MODE ON (factory setting): If the current reference weight is less than the minimum reference weight, the display shows ADD ... PCS or ADD ... and counting can not be commenced until the required reference pieces have been placed on the weighing platform. • ADD-MODE OFF: If the current reference weight is less than the minimum reference weight, the display shows * ... PCS or * ... and counting can be commenced immediately.
Comment	<p>If the current reference weight is less than 10 % of the minimum reference weight, the display shows REF WEIGHT TOO LOW.</p> <p>Example: Minimum reference weight 10 g. The message REF WEIGHT TOO LOW appears when the reference weight placed on the weighing platform weighs less than 1 g.</p>

PREFERRED REF SCALE	Select preferred reference weighing platform for determining reference value
	<p>Only possible when several weighing platforms are connected. Factory setting: weighing platform with highest resolution.</p>

CORRECTION FACTOR	Enter the correction factor for the quantity or the value of the physical variable (e. g. length)
	<p>The quantity or the value of the physical variable (e. g. length) is calculated from the current reference piece weight and the weight of all pieces, multiplied by the correction factor and the result displayed. Access is protected with a code. Possible factors: 0.10 ... 10.00 in steps of 0.01 (factory setting: 1.00)</p>
CODE	Specify the access code.
Comments	<ul style="list-style-type: none"> • With a correction factor < 1.00 a sufficient quantity or a sufficient value of the physical variable (e. g. length) is always achieved. • If a correction factor other than 1.00 is entered, the unit of the quantity is marked: "PCS" becomes "PC".

ARTICLE NUMBER	Activate or deactivate display of reference weight memory with article number
	<p>If ARTICLE NUMBER ON is selected, you can start counting by entering the article number.</p> <p>If a barcode reader is also connected, then the reference weight can be read in with the barcode reader.</p> <p>Factory setting: ARTICLE NUMBER OFF</p>
FIX REF WEIGHT UPDATE	<p>If FIX REF WEIGHT UPDATE ON is selected, a new reference weight can be entered in the weighing mode after displaying the read-only memory.</p> <p>Factory setting: FIX REF WEIGHT UPDATE OFF</p>
AUTO REPLACE	<p>If AUTO REPLACE ON is selected, the oldest memory entry is cleared to create space for the new article when the article memory is full.</p>
NEW ARTICLE PROMPT	<p>If NEW ARTICLE PROMPT OFF is selected, counting can only be started by entering stored article numbers.</p>

DELAYED SUM CLEAR	Clearing of the sums in the application blocks when a new counting process is started or after the SUM and CLEAR keys have been pressed
	<p>If DELAYED SUM CLEAR ON is set (factory setting), the sums in the application blocks are not cleared until a new counting process is started.</p> <p>If DELAYED SUM CLEAR OFF is set, the sums in the application blocks are cleared when the SUM and CLEAR keys are pressed.</p>

PRE TARE OPTION	Assigning of a fixed tare weight for the stored reference weight
	<p>If PRE TARE OPTION ON is set (factory settings) a tare read-only memory can be assigned to every reference weight read-only memory. When the reference weight read-only memory is called up, a tare is deducted automatically.</p>

RESET PAC	Reset functions to factory setting	
	Block	Factory setting
	APPLICATION	counting
	STANDARD REF PIECES	10
	UNIT REF WEIGHT INPUT	g for main unit kg; oz for main unit lb
	ITEM COUNTER	start value 1, stop value 9999
	CLEARING OF TOTAL	on
	MIN REF WEIGHT	second smallest, permissible value
	REF. OPTIMIZATION	off
	ADD-MODE	on
	PREFERRED REF SCALE	weighing platform with highest resolution
	CORRECTION FACTOR	1.00
	ARTICLE NUMBER	off
	FIX REF WEIGHT UPDATE	off
	DELAYED SUM CLEAR	on
	PRE TARE OPTION	on

2.2.1 PIECE-FILLING application

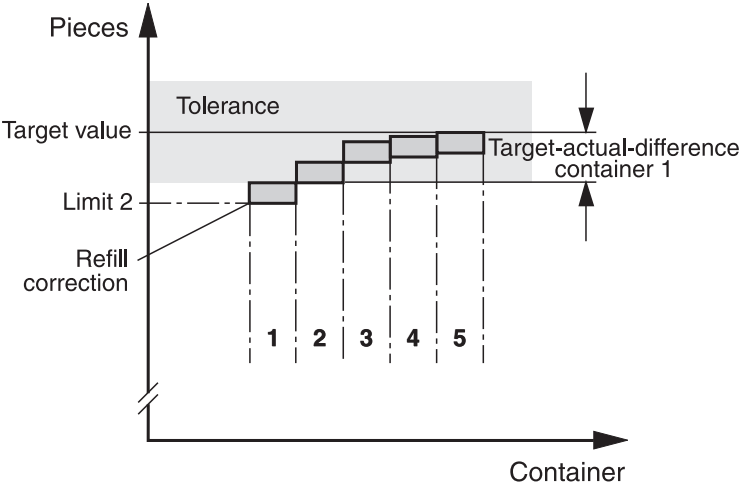
PIECE-FILLING	Automatic filling when specifying a target value
FILLING TYPE	Possible settings: <ul style="list-style-type: none"> • WEIGHING-IN • SUBTRACTIVE WEIGHING
AUTO TOTALIZE	Switch automatic totalizing after each filling process on or off
AUTOMATIC TARE	Switch automatic taring on or off during each filling process
REFILL CORRECTION	<p>Switch refill correction on or off</p> <p>The refill correction optimizes the switch-off point of the fine feed (limit 2). The difference between the target and actual value (target-actual difference) is determined for the 1st container and multiplied with a FACTOR. Limit 2 is automatically corrected by this value Δ when filling the next container: $\Delta = \text{FACTOR} \times \text{target-actual difference}$.</p> <p>Example: For a target-actual difference of 10 PCS and a FACTOR of 0.5, limit 2 is corrected by 5 PCS.</p> <p>Limit 2 is corrected until the quantity of a container matches the target value.</p>  <p>The more unstable the material flow is, the lower the factor should be. Possible entries for the FACTOR: 0.0 ... 0.9</p>
SAFETY FACTOR	<p>The safety factor specifies how long the fine feed is open in the learn mode. The larger the safety factor, the more accurately the fine feed run-on can be determined.</p> <p>Possible settings: SAFETY FACTOR = 1.0 ... 1.9 (factory setting: 1.5)</p>

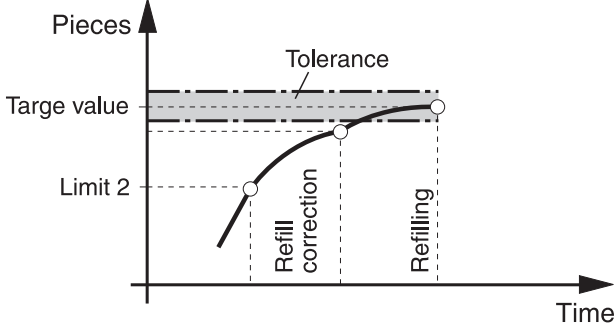
PIECE-FILLING	Automatic filling when specifying a target value
REFILLING	<p>Switch automatic refilling on or off If the quantity briefly overshoots, the fine feed is switched off too early and the current quantity lies below the target value. During refilling the fine feed is opened again in intervals until the target value is reached.</p>  <p>Possible entries:</p> <ul style="list-style-type: none"> • PULSE DURATION – The fine feed is opened during the pulse duration. Possible values: 1 ... 99 in intervals of 230 milliseconds • PULSE PAUSE – The fine feed is switched off during the pulse pause. Possible values: 0 ... 99 in intervals of 230 milliseconds
Comment	For the connection diagram and terminal assignment for the 8-690 relay box, see section 6.1.

2.2.2 NEUTRAL MEASUREMENT application

NEUTRAL MEASUREMENT	Derive other physical variables, e. g. length, area, volume, from the weight value
FORMAT	<p>Set the representation of the physical variable Possible formats: 0; 0.0; 0.00; 0.000</p>
TEXT	<p>Set the denomination of the physical variable Possible entries: enter a maximum of 10 characters and confirm with the ENTER key, e. g. "Contents".</p>
UNIT	<p>Enter the unit of the physical variable Possible entries: enter a maximum of 3 characters and confirm with the ENTER key, e. g. m, cm, mm, lit, ccm, etc.</p>

2.2.3 CountTool

CountTool is a free configuration and editing tool for IND690-Count which runs on every PC. It communicates with the IND690-Count via a serial interface or Ethernet/WLAN and enables convenient configuration and data management, monitoring and conversion from and to ACCESS databases.

Please ask METTLER TOLEDO Customer Service about CountTool.

Setting parameters

All the master mode settings can be made on a screen with CountTool in a clear and concise manner.

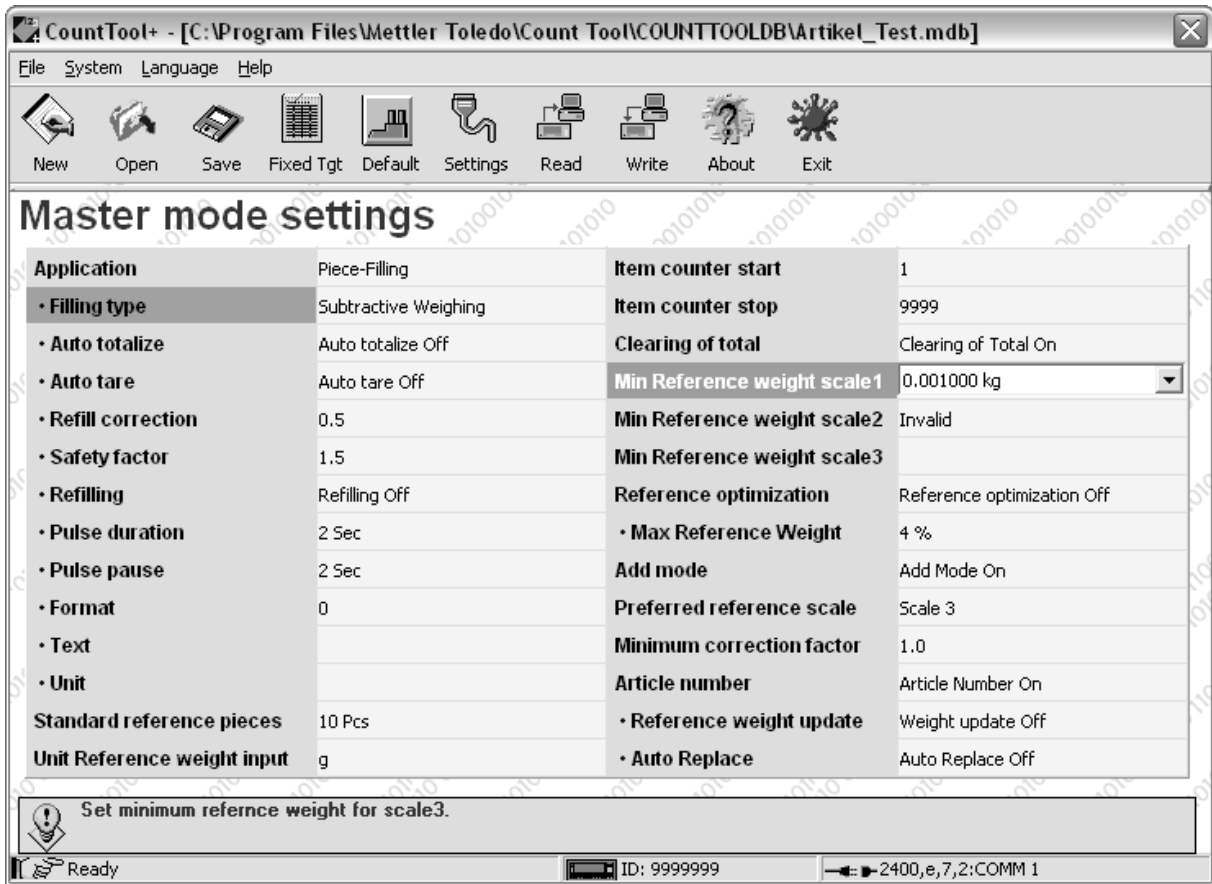

Editing fixed values

Fixed values can be edited easily with CountTool.

The screenshot shows the CountTool+ application window with the following menu and toolbar options:

- File System Language Help
- New Open Save Master Md Default Settings Read Write About Exit

The main window displays a table titled "Fixed Target Entries - Piece-Filling":

Index	Article Number	Name	Ref Weight	Target(Pcs)	Limit1(Pcs)	Lir
1	1244322344	Artikel_001	0.234 kg	469	340	460
2	7889785543	Artikel_002	0.445 kg	500	300	400
3	3345225343	Artikel_003	0.884 kg	1300	1000	1250
4	8789712332	Artikel_004	1.345 kg	20	14	19
5	9923123333	Artikel_005	0.231 kg	3000	2400	2900
6						
7						
8						
9						
10						
11						
12						

Below the table, a status bar contains the instruction: "Press F2 to Edit, F3 to Save, F4 to Delete and F5 to cancel." The bottom status bar shows "Ready", "ID: 9999999", and "2400,e,7,2:COMM 1".

3 Application blocks

In the following description, the application blocks are shown in the syntax for the MMR command set. When used with the SICS command set, please observe the SICS conventions, see Operating instructions for IND690-... weighing terminal.

No.	Content	Format
301	Pac version	Response: <code>A,B _ IND690-Count_V1.xx</code>
302	Program number	Response: <code>A,B _ IP63-0-0xxx_</code>
307_001 ... 307_999	Article numbers for read-only memories 332_001... 332_999	Response: <code>A,B _ Text_20</code> Write: <code>A,W 3,0,7 _ x,x,x Text_20</code> Comment: xxx = 001 ... 999 Only when ARTICLE NUMBER ON is selected in the master mode.
308_001 ... 308_999	Tare weights for read-only memories 332_001... 332_999	Response: <code>A,B _ Weight value</code> Write: <code>A,W 3,0,8 _ x,x,x _ Weight value _ Unit</code> Comment: xxx = 001 ... 999 Only when ARTICLE NUMBER ON is selected in the master mode.
310	Current quantity	Response: <code>A,B _ Number_10 _ Unit</code> Unit = PCS Comment: for COUNTING and PIECE-FILLING applications
311	Current piece weight/ current dispensing parameters	Response: COUNTING and NEUTRAL MEASUREMENT <code>A,B _ Text_20 _ _ Weight value _ Unit</code> PIECE FILLING <code>A,B _ Name (Text_20) _ _</code> <code>Piece weight (weight value) _ Unit _ _</code> <code>Target pieces (Number_10) _ Unit _ _</code> <code>Limit 1 (Number_10) _ Unit _ _</code> <code>Limit 2 (Number_10) _ Unit _ _</code> <code>Tolerance(-) (Number_10) _ Unit _ _</code> <code>Tolerance(+) (Number_10) _ Unit</code> Write: COUNTING and NEUTRAL MEASUREMENT <code>A,W 3,1,1 _ Text_20 \$,\$ Weight value _ Unit</code> PIECE FILLING <code>A,W 3,x,x _ Name (Text_20) \$,\$</code> <code>Piece weight (weight value) _ Unit \$,\$</code> <code>Target pieces (Number_10) _ Unit \$,\$</code> <code>Limit 1 (Number_10) _ Unit \$,\$</code> <code>Limit 2 (Number_10) _ Unit \$,\$</code> <code>Tolerance(-) (Number_10) _ Unit \$,\$</code> <code>Tolerance(+) (Number_10) _ Unit</code> Note: Start counting, as with REF W key

No.	Content	Format
312	Reference quantity or reference variable	Response: <input type="text" value="A, B"/> <input type="text" value="Number_10"/> <input type="text" value="Unit"/> Write: <input type="text" value="A, W 3, 1, 2"/> <input type="text" value="Number_10"/> <input type="text" value="Unit"/> Comment: Start counting, as with REF N key for the COUNTING and PIECE-FILLING applications, the reference quantity is displayed with unit = PCS for the NEUTRAL MEASUREMENT application the reference variable is displayed without a unit, and decimal places are also possible
313	Item counter	Response: <input type="text" value="A, B"/> <input type="text" value="Number_4"/>
314	Sum of quantity or sum of physical variable (e.g. length)	Response: <input type="text" value="A, B"/> <input type="text" value="Number_10"/> <input type="text" value="Unit"/> Comment: for the COUNTING and PIECE-FILLING applications the sum is displayed with unit = PCS for the NEUTRAL MEASUREMENT application the sum is displayed without a unit
315	Sum net weight	Response: <input type="text" value="A, B"/> <input type="text" value="Weight value"/> <input type="text" value="Unit"/>
316	Sum gross weight	Response: <input type="text" value="A, B"/> <input type="text" value="Weight value"/> <input type="text" value="Unit"/>
317	Standard reference quantity or standard reference variable	Response: <input type="text" value="A, B"/> <input type="text" value="Number_10"/> <input type="text" value="Unit"/> Write: <input type="text" value="A, W 3, 1, 7"/> <input type="text" value="Number_4"/> <input type="text" value="Unit"/> Comment: for the COUNTING and PIECE-FILLING applications the standard reference quantity is displayed with unit = PCS for the NEUTRAL MEASUREMENT application the standard reference variable is displayed without a unit, and decimal places are also possible
318_001 ... 318_006	Identification data Code A ... Code F	Response: <input type="text" value="A, B"/> <input type="text" value="Name (text_20)"/> <input type="text" value="Identification (text_20)"/> Write: <input type="text" value="A, W 3, x, x"/> <input type="text" value="Name (text_20)"/> <input type="text" value="\$"/> <input type="text" value="\$"/> <input type="text" value="Identification (text_20)"/> Comment: xx = 18_001 ... 18_006; corresponds to the application blocks 094 ... 099
318 ... 321	Identification data Code A ... Code D	Response: equal to 318_001 Write: equal to 318_001 Comment: xx = 18 ... 21; corresponds to the application blocks 094 ... 097
322_001 ... 322_004	Minimum reference weight weighing platform 1 ... 4	Response: <input type="text" value="A, B"/> <input type="text" value="Weight value"/> <input type="text" value="Unit"/> Write: <input type="text" value="A, W 3, 2, x"/> <input type="text" value="Weight value"/> <input type="text" value="Unit"/> Comment: x = 2_001 ... 2_004
322 ... 324	Minimum reference weight weighing platform 1 ... 3	Response: equal to 322_001 Write: equal to 322_001 Comment: corresponds to the application blocks 322_001 ... 322_003
325_001 ... 325_004	Counter limit weight weighing platform 1 ... 4	Response: <input type="text" value="A, B"/> <input type="text" value="Weight value"/> <input type="text" value="Unit"/>

No.	Content	Format
325 ... 327	Counter limit weight weighing platform 1 ... 3	Response: equal to 325_001 Comment: corresponds to the application blocks 325_001 ... 325_003
328	Start value item counter	Response: <input type="text" value="A, B _ Number_4"/> Write: <input type="text" value="A, W 3, 2, 8 _ Number_4"/>
329	Unit reference weight for entering the piece weight	Response: <input type="text" value="A, B _ Unit"/> Write: <input type="text" value="A, W 3, 2, 9 _ Unit"/>
330	Sum quantity without unit	Response: <input type="text" value="A, B _ Number_10"/>
331	Safety factor	Response: <input type="text" value="A, B _ 1, ., x"/> x = 0 ... 9 Write: <input type="text" value="A, W 3, 3, 1 _ 1, ., x"/> x = 0 ... 9
332_001 ... 332_999	COUNTING application: Reference piece weight memory 1 ... 999 PIECE-FILLING application: Target memory 1 ... 999	Response: COUNTING and NEUTRAL MEASUREMENT <input type="text" value="A, B _ Name (text_20) _ _"/> <input type="text" value="Piece weight (weight value) _ Unit"/> PIECE-FILLING <input type="text" value="A, B _ Name (text_20) _ _"/> <input type="text" value="Piece weight (weight value) _ Unit _ _"/> <input type="text" value="Target quantity (number_10) _ Unit _ _"/> <input type="text" value="Limit 1 (number_10) _ Unit _ _"/> <input type="text" value="Limit 2 (number_10) _ Unit _ _"/> <input type="text" value="Tolerance(-) (number_10) _ Unit _ _"/> <input type="text" value="Tolerance(+) (number_10) _ Unit"/> Write: COUNTING and NEUTRAL MEASUREMENT <input type="text" value="A, W 3, x, x _ Name (text_20) \$, \$"/> <input type="text" value="Piece weight (weight value) _ Unit"/> PIECE-FILLING <input type="text" value="A, W 3, x, x _ Name (text_20) \$, \$"/> <input type="text" value="Piece weight (weight value) _ Unit \$, \$"/> <input type="text" value="Target quantity (number_10) _ Unit \$, \$"/> <input type="text" value="Limit 1 (number_10) _ Unit \$, \$"/> <input type="text" value="Limit 2 (number_10) _ Unit \$, \$"/> <input type="text" value="Tolerance(-) (number_10) _ Unit \$, \$"/> <input type="text" value="Tolerance(+) (number_10) _ Unit"/> Comment: xx = 32_001 ... 32_999 Unit = PCS
332 ... 356	COUNTING: Reference piece weight memory 1 ... 25 PIECE-FILLING: Target memory 1 ... 25	Response: as for 332_001 ... 332_999 Write: as for 332_001 ... 332_999 Note: xx = 32 ... 56 The contents of the target memory 1 ... 25 are identical to the contents of the target memory 332_001 ... 332_025. Unit = PCS

No.	Content	Format
357	Format	Response: <input type="text" value="A,B"/> <input type="text" value="Number (right-justified)"/> Write: <input type="text" value="A,W 3,5,7"/> <input type="text" value="Number (right-justified)"/> Comment: only for the NEUTRAL MEASUREMENT application Data format number: 0; 0.0; 0.00; 0.000
358	Preferred reference weighing platform	Response: <input type="text" value="A,B"/> <input type="text" value="n"/> Write: <input type="text" value="A,W 3,5,8"/> <input type="text" value="n"/> Comment: n = 1 ... 4, integral
359	Best reference weighing platform	Response: <input type="text" value="A,B"/> <input type="text" value="n"/> Comment: n = 1 ... 4, integral
360	Stop value item counter	Response: <input type="text" value="A,B"/> <input type="text" value="Number_4"/> Write: <input type="text" value="A,W 3,6,0"/> <input type="text" value="Number_4"/>
361	Current quantity without unit	Response: <input type="text" value="A,B"/> <input type="text" value="Number_10"/>
362	Sum tare weight	Response: <input type="text" value="A,B"/> <input type="text" value="Weight value"/> <input type="text" value="Unit"/>
363 ... 387	Text memory 21 ... 45	Response: <input type="text" value="A,B"/> <input type="text" value="Text_20"/> Write: <input type="text" value="A,W 3,x,x"/> <input type="text" value="Text_20"/> Comment: xx = 63 ... 87 The contents of the text memory 21 ... 45 are identical to the contents of the target read-only memory 071_021 ... 071_045.
388	Correction factor	Response: <input type="text" value="A,B"/> <input type="text" value="Factor"/> Write: <input type="text" value="A,W 3,8,8"/> <input type="text" value="Factor"/> Comment: Factor: 0.10 ... 10.00; step size 0.01
389	Denomination of the physical variable	Response: <input type="text" value="A,B"/> <input type="text" value="Text_10"/> Write: <input type="text" value="A,W 3,8,9"/> <input type="text" value="Text_10"/> Comment: only for the NEUTRAL MEASUREMENT application
390	Factor for refilling correction	Response: <input type="text" value="A,B"/> <input type="text" value="Factor"/> Write: <input type="text" value="A,W 3,9,0"/> <input type="text" value="Factor"/> Comment: Factor: 0.0 ... 0.9; step size 0.1

No.	Content	Format																																								
391	Filling status for PIECE-FILLING application	Response: <input type="text" value="A"/> <input type="text" value="B"/> <input type="text" value="Code (number_3)"/> , e.g.: <table border="0"> <thead> <tr> <th>Code</th> <th>Meaning</th> </tr> </thead> <tbody> <tr><td>000</td><td>Switch-on or basic state</td></tr> <tr><td>010</td><td>Ready for dispensing (filling parameters loaded)</td></tr> <tr><td>011</td><td>Display SUM after pressing the SUM key</td></tr> <tr><td>015, 016</td><td>Taring process running (triggered with external key)</td></tr> <tr><td>021, 022</td><td>Fine feed off due to/after overloading or underloading</td></tr> <tr><td>030</td><td>Taring process running (with automatic tare)</td></tr> <tr><td>040</td><td>Coarse feed on</td></tr> <tr><td>041, 042</td><td>Coarse feed off with external STOP key</td></tr> <tr><td>045, 046</td><td>Coarse feed off with/after overloading or underloading</td></tr> <tr><td>050</td><td>Fine feed on</td></tr> <tr><td>051, 052</td><td>Fine feed off with external STOP key</td></tr> <tr><td>055, 056</td><td>Fine feed off due to overloading or underloading</td></tr> <tr><td>070</td><td>Filling ended: Wait for stability</td></tr> <tr><td>071, 072</td><td>Filling ended with external STOP key</td></tr> <tr><td>073, 074</td><td>Refilling: During the pulse pause fine feed on with external STOP key</td></tr> <tr><td>075</td><td>Refilling: During the pulse duration fine feed on</td></tr> <tr><td>076</td><td>Refilling: During the pulse pause fine feed off</td></tr> <tr><td>077, 078</td><td>Refilling: During the pulse duration Fine feed off with external STOP key</td></tr> <tr><td>083</td><td>Filling ended: Display OKAY</td></tr> </tbody> </table> See next page.	Code	Meaning	000	Switch-on or basic state	010	Ready for dispensing (filling parameters loaded)	011	Display SUM after pressing the SUM key	015, 016	Taring process running (triggered with external key)	021, 022	Fine feed off due to/after overloading or underloading	030	Taring process running (with automatic tare)	040	Coarse feed on	041, 042	Coarse feed off with external STOP key	045, 046	Coarse feed off with/after overloading or underloading	050	Fine feed on	051, 052	Fine feed off with external STOP key	055, 056	Fine feed off due to overloading or underloading	070	Filling ended: Wait for stability	071, 072	Filling ended with external STOP key	073, 074	Refilling: During the pulse pause fine feed on with external STOP key	075	Refilling: During the pulse duration fine feed on	076	Refilling: During the pulse pause fine feed off	077, 078	Refilling: During the pulse duration Fine feed off with external STOP key	083	Filling ended: Display OKAY
Code	Meaning																																									
000	Switch-on or basic state																																									
010	Ready for dispensing (filling parameters loaded)																																									
011	Display SUM after pressing the SUM key																																									
015, 016	Taring process running (triggered with external key)																																									
021, 022	Fine feed off due to/after overloading or underloading																																									
030	Taring process running (with automatic tare)																																									
040	Coarse feed on																																									
041, 042	Coarse feed off with external STOP key																																									
045, 046	Coarse feed off with/after overloading or underloading																																									
050	Fine feed on																																									
051, 052	Fine feed off with external STOP key																																									
055, 056	Fine feed off due to overloading or underloading																																									
070	Filling ended: Wait for stability																																									
071, 072	Filling ended with external STOP key																																									
073, 074	Refilling: During the pulse pause fine feed on with external STOP key																																									
075	Refilling: During the pulse duration fine feed on																																									
076	Refilling: During the pulse pause fine feed off																																									
077, 078	Refilling: During the pulse duration Fine feed off with external STOP key																																									
083	Filling ended: Display OKAY																																									
391	Filling status for the PIECE-FILLING application	Response: <input type="text" value="A"/> <input type="text" value="B"/> <input type="text" value="Code (number_3)"/> , e.g.: <table border="0"> <thead> <tr> <th>Code</th> <th>Meaning</th> </tr> </thead> <tbody> <tr><td>086</td><td>Filling ended: Display SURPLUS</td></tr> <tr><td>087</td><td>Output sum following sum overflow or after the stop value of the item counter is reached</td></tr> <tr><td>100</td><td>After end of filling: Total</td></tr> <tr><td>101</td><td>After end of filling: Wait for movement</td></tr> <tr><td>102</td><td>After end of filling: Wait for new start</td></tr> <tr><td>110</td><td>Filling ended: Display DEFICIT</td></tr> <tr><td>112, 113</td><td>Filling cancelled with STOP key</td></tr> <tr><td>114</td><td>After incorrect filling: Display CORRECT</td></tr> <tr><td>116</td><td>After incorrect filling: Display CONFIRM</td></tr> <tr><td>235, 236</td><td>Learn mode: Fine feed off due to/after overloading or underloading</td></tr> <tr><td>241</td><td>Learn mode: Coarse feed off, wait for stabilization</td></tr> <tr><td>242, 243</td><td>Learn mode: Coarse feed off with external STOP key</td></tr> <tr><td>245</td><td>Learn mode: Fine feed on</td></tr> <tr><td>246, 247</td><td>Learn mode: Fine feed off with external STOP key</td></tr> <tr><td>248</td><td>Learn mode: Fine feed off, wait for stabilization</td></tr> <tr><td>249, 250</td><td>Learn mode: Interruption with external STOP key</td></tr> </tbody> </table>	Code	Meaning	086	Filling ended: Display SURPLUS	087	Output sum following sum overflow or after the stop value of the item counter is reached	100	After end of filling: Total	101	After end of filling: Wait for movement	102	After end of filling: Wait for new start	110	Filling ended: Display DEFICIT	112, 113	Filling cancelled with STOP key	114	After incorrect filling: Display CORRECT	116	After incorrect filling: Display CONFIRM	235, 236	Learn mode: Fine feed off due to/after overloading or underloading	241	Learn mode: Coarse feed off, wait for stabilization	242, 243	Learn mode: Coarse feed off with external STOP key	245	Learn mode: Fine feed on	246, 247	Learn mode: Fine feed off with external STOP key	248	Learn mode: Fine feed off, wait for stabilization	249, 250	Learn mode: Interruption with external STOP key						
Code	Meaning																																									
086	Filling ended: Display SURPLUS																																									
087	Output sum following sum overflow or after the stop value of the item counter is reached																																									
100	After end of filling: Total																																									
101	After end of filling: Wait for movement																																									
102	After end of filling: Wait for new start																																									
110	Filling ended: Display DEFICIT																																									
112, 113	Filling cancelled with STOP key																																									
114	After incorrect filling: Display CORRECT																																									
116	After incorrect filling: Display CONFIRM																																									
235, 236	Learn mode: Fine feed off due to/after overloading or underloading																																									
241	Learn mode: Coarse feed off, wait for stabilization																																									
242, 243	Learn mode: Coarse feed off with external STOP key																																									
245	Learn mode: Fine feed on																																									
246, 247	Learn mode: Fine feed off with external STOP key																																									
248	Learn mode: Fine feed off, wait for stabilization																																									
249, 250	Learn mode: Interruption with external STOP key																																									
392	Mean value \bar{x} for piece weight of samples (statistics)	Response: <input type="text" value="A"/> <input type="text" value="B"/> <input type="text" value="Weight value"/> <input type="text" value="Unit"/>																																								

No.	Content	Format
393	Standard deviation s for piece weight of samples (statistics)	Response: <input type="text" value="A"/> <input type="text" value="B"/> <input type="text" value="Weight value"/> <input type="text" value="Unit"/>
394	Minimum min for piece weight of samples (statistics)	Response: <input type="text" value="A"/> <input type="text" value="B"/> <input type="text" value="Weight value"/> <input type="text" value="Unit"/>
395	Maximum max for piece weight of samples (statistics)	Response: <input type="text" value="A"/> <input type="text" value="B"/> <input type="text" value="Weight value"/> <input type="text" value="Unit"/>
396	Number n of samples (statistics)	Response: <input type="text" value="A"/> <input type="text" value="B"/> <input type="text" value="Number_4"/>
397	Piece weight of current sample (statistics)	Response: <input type="text" value="A"/> <input type="text" value="B"/> <input type="text" value="Weight value"/> <input type="text" value="Unit"/>
398	Barcode EAN 25	Response: <input type="text" value="A"/> <input type="text" value="B"/> <input type="text" value="2"/> <input type="text" value="5"/> <input type="text" value="Article"/> <input type="text" value="Check digit"/> <input type="text" value="Quantity"/> Comment: Article: 4-digit article no. from memory Code A Check digit: 1-digit no., calculated by IND690-Count Quantity: 5-digit
399	Barcode EAN 26, EAN 128 - 30	Response: <input type="text" value="A"/> <input type="text" value="B"/> <input type="text" value="EAN 26"/> <input type="text" value="EAN 128-30"/> EAN 26: <input type="text" value="2"/> <input type="text" value="6"/> <input type="text" value="Article"/> <input type="text" value="Check digit"/> <input type="text" value="Pieces"/> Article: 4-digit Article No. from memory Code A Check digit: 1-digit, calculated by IND690-Count for the weight Pieces: 5-digit EAN 128-30: <input type="text" value="0"/> <input type="text" value="1"/> <input type="text" value="9"/> <input type="text" value="Article"/> <input type="text" value="Check digit"/> <input type="text" value="3"/> <input type="text" value="0"/> <input type="text" value="Pieces"/> <input type="text" value="x"/> or <input type="text" value="0"/> <input type="text" value="1"/> <input type="text" value="9"/> <input type="text" value="Article"/> <input type="text" value="3"/> <input type="text" value="0"/> <input type="text" value="Pieces"/> <input type="text" value="x"/> Article: Article No. from memory Code A max. 12 or 13 digits Check digit: 1-digit, calculated by IND690-Count Pieces: x-digit pieces from Block 310 x: 0, 2, 4, 6, 8: Number of places for pieces 0: lowest possible even number of places

4 What to do if ...?

Error / Display	Possible causes	Remedy
REF. WEIGHT TOO LOW	<ul style="list-style-type: none"> Reference weight below counting limit weight, i.e. below 10 % of minimum reference weight 	<ul style="list-style-type: none"> → Increase reference weight with larger reference quantity → If present, use more precise weighing platform
ADD ... ITEMS	<ul style="list-style-type: none"> Reference weight is below minimum weight specific to weighing platform 	<ul style="list-style-type: none"> → Increase reference quantity by specified quantity and confirm with ENTER → Ignore warning by pressing keys for fixed or variable reference quantity
OVERFLOW PIECES	<ul style="list-style-type: none"> Capacity of quantity display exceeded 	<ul style="list-style-type: none"> → Relieve weighing platform and divide counting sample into sub-quantities
OVERFLOW SUM GROSS OVERFLOW SUM NET	<ul style="list-style-type: none"> Capacity of buffer for sum weight exceeded 	<ul style="list-style-type: none"> → Delete sum
OVERFLOW ITEMCOUNTER	<ul style="list-style-type: none"> Itemcounter has reached stop value 	<ul style="list-style-type: none"> → Delete itemcounter → Check start value and stop value of itemcounter if necessary
WRONG SCALE	<ul style="list-style-type: none"> Invalid scale number entered 	<ul style="list-style-type: none"> → Enter scale number for an installed weighing scale
WRONG SAMPLE	<ul style="list-style-type: none"> Sample too large or too small for statistics 	<ul style="list-style-type: none"> → Place right sample on weighing platform
INPUTS/OUTPUTS MISSING	<ul style="list-style-type: none"> No inputs/outputs available on IND690-Count 	<ul style="list-style-type: none"> → Configure inputs/outputs
WRONG CODE	<ul style="list-style-type: none"> Wrong password entered 	<ul style="list-style-type: none"> → Enter right password
Display shows running value without unit	<ul style="list-style-type: none"> NEUTRAL MEASUREMENT activated and no unit defined 	<ul style="list-style-type: none"> → Enter unit for NEUTRAL MEASUREMENT application

5 Technical data

Counting functions	
Quantity	Continuously running display, 7-place (up to 9 999 999 pieces)
Piece weight determination	Either from standard reference pieces or variable reference pieces (1 ... 9 999 pieces)
Piece weight entry	Entry of up to 8 places including decimal point in various weight units
Piece weight memory	<ul style="list-style-type: none"> • 999 memories for frequently used counting parts, protected against power failure • With 20-place alphanumeric article designation • With 20-place alphanumeric article number
Target memory	<ul style="list-style-type: none"> • 999 memories for frequently used target values, protected against power failure • With 20-place alphanumeric identification • With 20-place alphanumeric article number • Only in PIECE-FILLING application
Minimum reference monitoring	Dependent on the connected weighing platform
Multi-scale systems	Preferred reference scale freely selectable
Neutral measurement	For simple determination of weight-dependent variables, e.g. lengths, areas, volumes
Totalizing	<ul style="list-style-type: none"> • In weighing mode: gross sum, net sum • For piece counting: gross sum, net sum, piece sum
Sum memory	Up to 8 places including decimal point
Item counter	Up to 9 999, start and stop value freely selectable

6 Appendix

6.1 Connection diagram and terminal assignment for 8-690 relay box

For the PIECE-FILLING application the IND690-Count requires the RS485-690 serial interface and the 8-690 relay box:

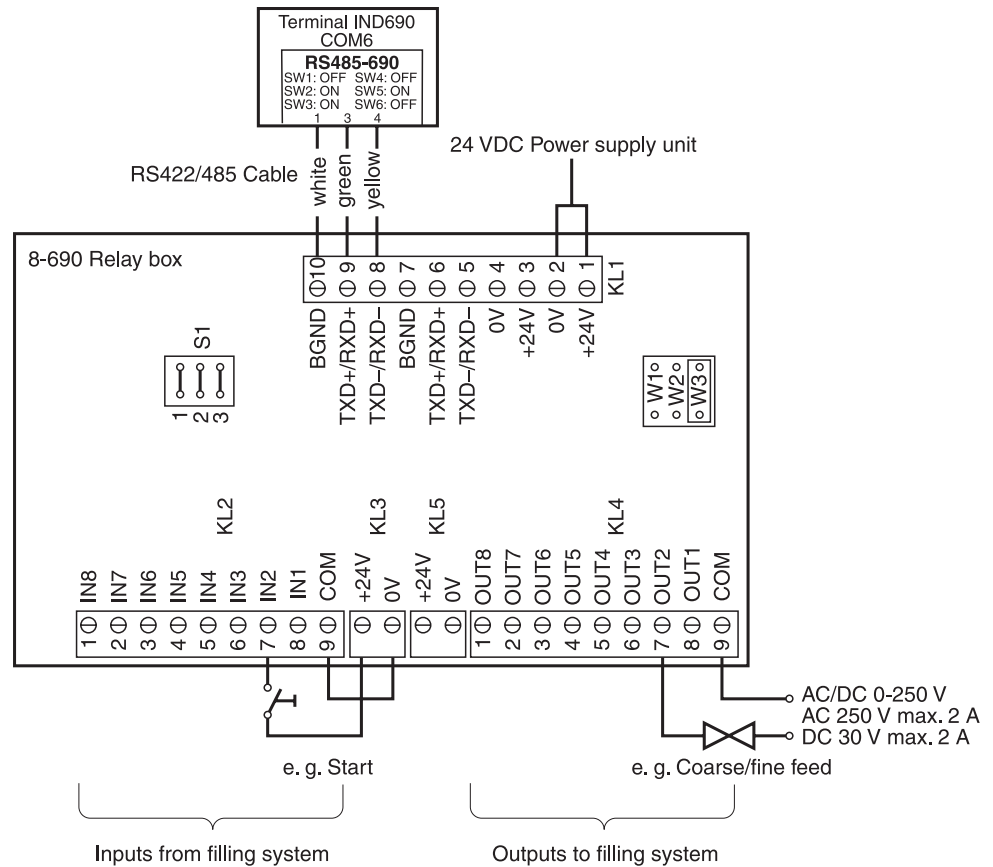

KL2	Assignment	Relay box: Inputs from filling system	KL4	Assignment	Relay box: Outputs to filling system
8	IN1	Not assigned	8	OUT1	On/off
7	IN2 *	Start (PLC)	7	OUT2	Coarse/fine feed
6	IN3	Stop (PLC)	6	OUT3	Not assigned
5	IN4 *	Confirm	5	OUT4	Underfilled
4	IN5	Tare	4	OUT5	Acceptable
3	IN6	Not assigned	3	OUT6	End of filling
2	IN7	Not assigned	2	OUT7	Overfilled
1	IN8	Not assigned	1	OUT8	Ready

* IN2 and IN4 can be connected and operated with a key.

Note

The 8-690 relay box can also be replaced with 4/I/O-690 interfaces and 4-690 relay boxes.

- | | | |
|----------------------------|---------------|---------------------------|
| 1. Relay box 4-690 on COM6 | IN1 ... IN4 | Terminal 2, IN0 ... IN3 |
| | OUT1 ... OUT4 | Terminal 3, OUT0 ... OUT3 |
| 2. Relay box 4-690 on COM5 | IN5 ... IN8 | Terminal 2, IN4 ... IN7 |
| | OUT5 ... OUT8 | Terminal 3, OUT4 ... OUT7 |

6.2 Connection suggestions for various vibration conveyors

Neutral connection

Control of a conveyor system with separate coarse feed and fine feed circuits:

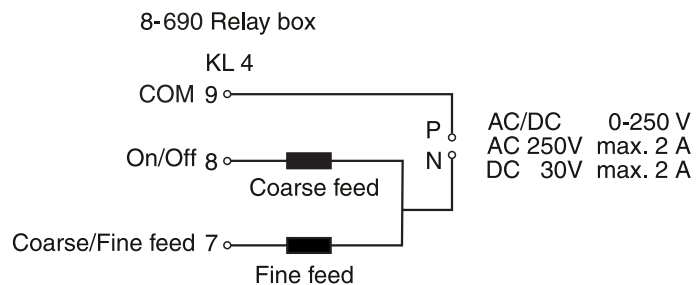
**External control unit (PLC)**

HSTD-10 control unit from Gericke:

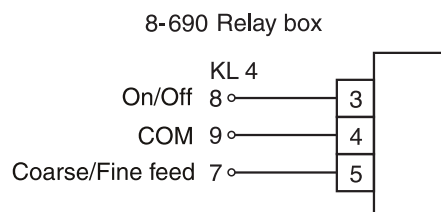

7 Index

A

Add mode 18, 27
Article number 5, 11, 16,
28, 34
Auto totalize 30
Automatic tare 9, 30

C

Coarse feed 9
Correction factor 27
Counting 4, 24
Counting functions 41

D

DeltaTrac 20

E

Error messages 40

F

Fine feed 9
Function keys 4, 8, 15

I

Item counter 26

L

Learn mode 10, 30

M

Min Ref Weight 26
Minimum reference
weight 18

N

Neutral measurement 15,
24

P

Piece-filling 8, 13, 24
Preferred reference weighing
platform 21, 27

R

Recall information 22
Redispensing 9
Redispensing correction 10,
30
Reference determination 5
Reference optimization 18,
26
Reference piece weight 4, 8
Reference weight 15, 18,
24
Reference weight
memory 24
Refilling 31
Reset Pac 29

S

Specify reference value 5,
11, 15
Statistics 19

T

Tare 34
Target memory 25
Technical data 41
Totalizing 7, 14, 17

W

What to do if ...? 40



22012816C

Subject to technical changes © Mettler-Toledo (Albstadt) GmbH 08/08 Printed in Germany 22012816C

Mettler-Toledo (Albstadt) GmbH

D-72458 Albstadt

Tel. ++49-7431-14 0, Fax ++49-7431-14 232

Internet: <http://www.mt.com>