

# TOC Analyzer

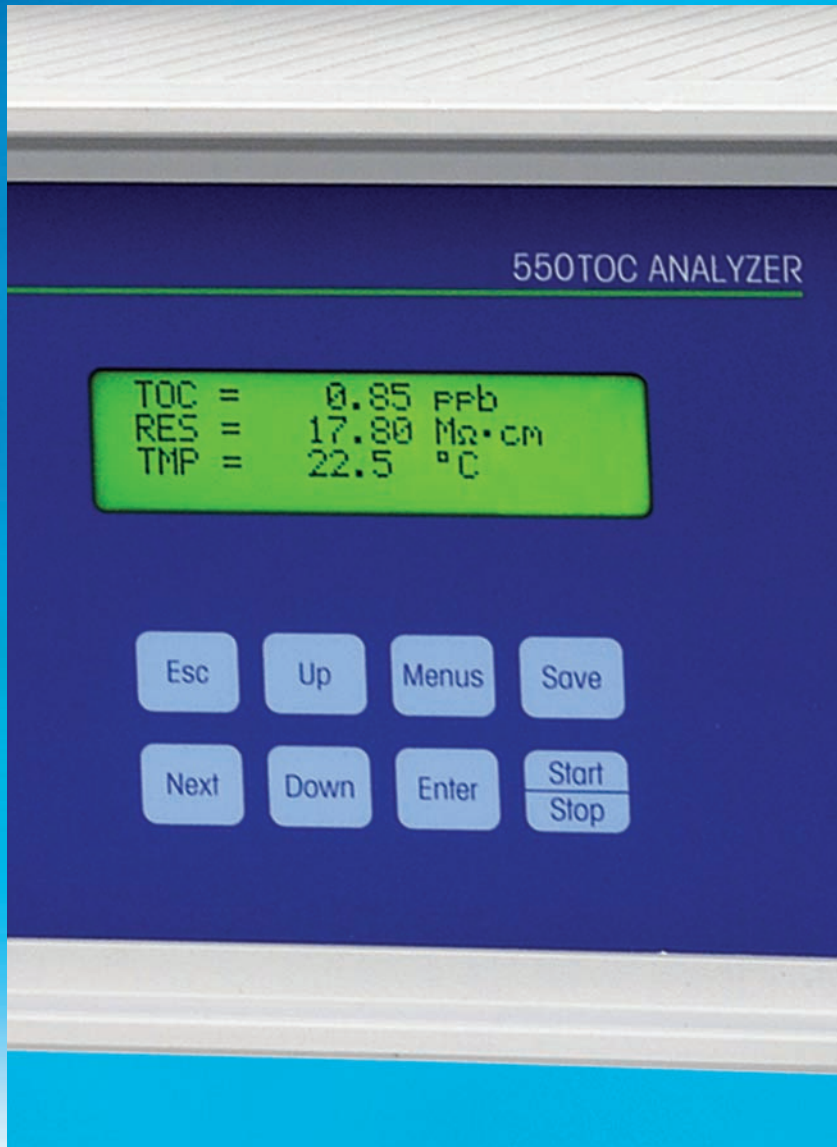

## THORNTON

Leading Pure Water Analytics

### 550TOC Analyzer

Continuous real-time TOC monitoring

Low maintenance design

No reagents or chemicals needed

No moving parts

Point-of-use or portable monitoring capability



**Versatile, Continuous monitoring**  
Total Organic Carbon Analyzer

METTLER TOLEDO

## Features

- Continuous analysis and rapid display updates
- Display TOC, resistivity or conductivity (compensated or uncompensated) and temperature simultaneously
- 4-20 mA analog output, user-selectable for TOC, resistivity/conductivity or temperature
- RS232 digital output for TOC, resistivity or conductivity (compensated or uncompensated) and temperature
- Two SPDT relay outputs for high/low setpoint alarms
- UV lamp run-time indication and expiration alarm
- User-defined password protection for setup and maintenance menus

## Benefits

- Wide dynamic operating range of 0.05 Mohm-cm to 18.2 Mohm-cm
- Real-time continuous monitoring, no time-consuming batch measurements
- Obtain real data as it happens and react with alarms when necessary
- Point-of-use or portable monitoring
- Low maintenance: no gases or reagents to handle, store or replace. No membranes or moving parts
- Easy access to UV lamp with diagnostics and lamp expiration alarm
- Small, flexible, versatile: use as an on-line monitor or throughout a system to profile TOC, resistivity, and temperature
- Meets USP <643> and EP 2.2.44 requirements for TOC and USP <645> for conductivity
- Meets ASTM D 5173 Standard Test Methods for on-line TOC monitoring

## Applications

**Pure and Ultrapure** water production requires monitoring of organic contamination throughout the treatment process. The 550TOC provides continuous, fast, and reliable monitoring of TOC levels from post-RO waters to point-of-use. With continuous on-line measurements, the 550TOC ensures that organic excursions will not be missed.

**Pharmaceutical-grade waters** must meet strict water quality requirements. This highly regulated industry mandates the monitoring of Total Organic Carbon levels for PW (Purified Water), WFI (Water for Injection) and HPW (Highly Purified Water). The instruments used in this application must also undergo periodic testing to verify their ability to accurately measure TOC. Testing requirements are mandated in the USP Chapter <643> and EP 2.2.44 guidelines. The 550TOC analyzer provides the performance needed to meet these requirements and USP <645> for conductivity, while offering added benefits such as continuous online measurement in a low-maintenance, easy-to-use package.

**Semiconductor manufacturing** processes have some of the most stringent specifications for organic contamination in pure and ultrapure water systems. Use the 550TOC throughout the plant to monitor the integrity of reverse osmosis membranes, the effectiveness of TOC destruct UV lamps, resin bed performance and shedding.

**Recycle and reclaim** applications take advantage of the fast analysis time. The 550TOC analyzer provides continuous monitoring, not batch cycles, with high and low set point alarms for TOC, resistivity or temperature to allow diversion from the fab or other secondary applications if proper water quality is not met.

**Power generation** makeup water treatment – from reverse osmosis to demineralizers, the 550TOC provides fast reliable monitoring of TOC contaminants in the water system. The 550TOC-HT Hi Temp version will monitor organics in fluids at elevated temperatures, to 90 °C.

**System profiling** is easy with the quick set up and portability of the 550TOC. Profile the water system for trouble shooting TOC excursions or to spot check TOC levels after various treatment processes throughout the plant. Continuous online measurements make fast data collection simple and easy.

## Principle of Operation

The Thornton 550TOC Analyzer measures Total Organic Carbon based on differential conductivity. The sample water enters the analyzer and passes through a pressure regulator, which controls sample pressure to downstream components. Here the sample splits into two flow paths, where a portion of the flow is directed to the by-pass line where resistivity/conductivity and temperature are measured. These values are represented on the LCD display. The remainder of the sample is directed through a second conductivity sensor, measuring the sample conductivity prior to oxidation. This conductivity measurement accounts for background ions and inorganic carbon (CO<sub>2</sub>) in the water stream. Next, the sample enters the oxidation chamber. As the sample moves through the oxidation chamber, it is subjected to high intensity ultraviolet radiation at 185 nanometers, effectively oxidizing the sample. After oxidation, the sample passes through a third conductivity sensor where the conductivity and temperature are measured again to determine the level of Total Organic Carbon (TOC). The measurement and sample flow are continuous; therefore, measurement update time is minimized, providing rapid response.

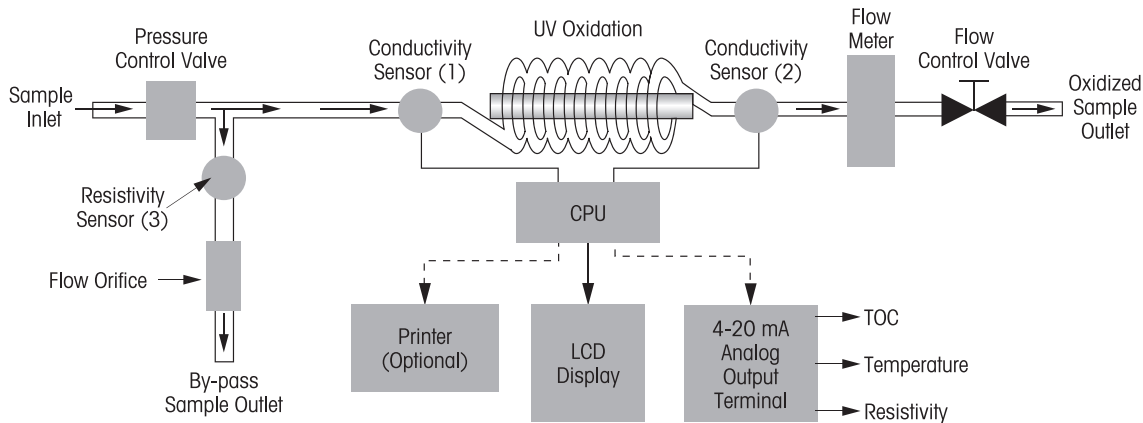

## 550TOC Analyzer Installation

The Thornton 550TOC Analyzer is designed to minimize installation and setup time. There are three tubing connections required; one for the sample inlet, one for the oxidized sample outlet and a third for the sample bypass flow. It is recommended that a valve be installed on the sample inlet as a shutoff valve to isolate the analyzer from the process line as needed (valve not supplied by Thornton).

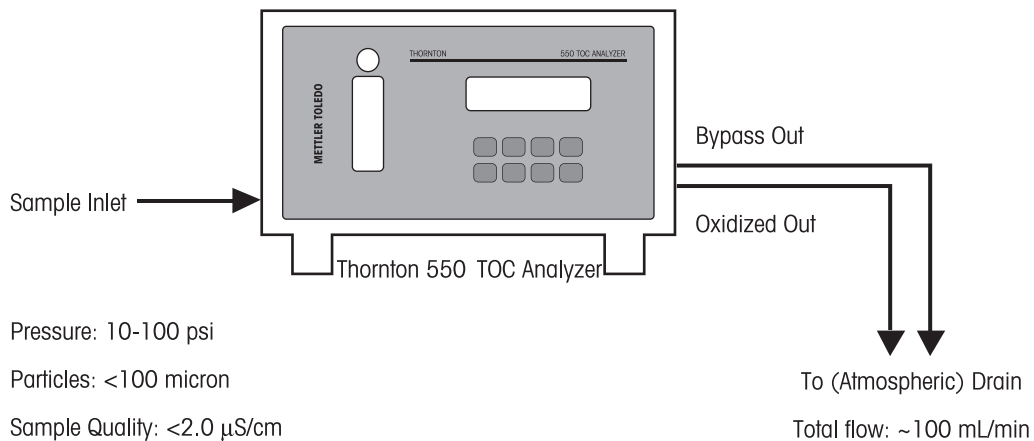

### 550TOC Performance

Description	550TOC-HT	
Measurement Range	0.1-1000 ppb	
Repeatability	± 0.1 ppb < 10 ppb TOC ± 1% > 10 ppb TOC	
Resolution	0.01 ppb	
Limit of Detection	0.1 ppb	
Linearity (Accuracy)*	1.00 ± 0.05	
Min. Water Quality**	> 0.5 MΩ-cm <2.0 μS/cm	
<b>Sample Water</b>	Resistivity/Conductivity	0.05-18.2 MΩ-cm (0.055-20 μS/cm)
	Temperature	5-90 °C
	Particle Size	< 100 μm
	Flow Rate	20 mL/min
	Pressure	10-100 psi at Inlet

\* Values expressed in terms of Slope, defined as TOC recovered vs. TOC injected based on tests performed using samples of known concentrations of organics.  
 \*\* Sample water quality requirements to meet stated TOC performance specifications shown.

Graphs show typical TOC recovery performance when injecting two known organics at various concentrations. Solid line represents Linearity (slope) = 1.

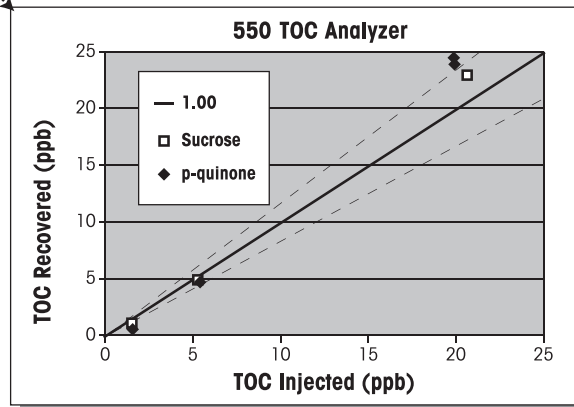
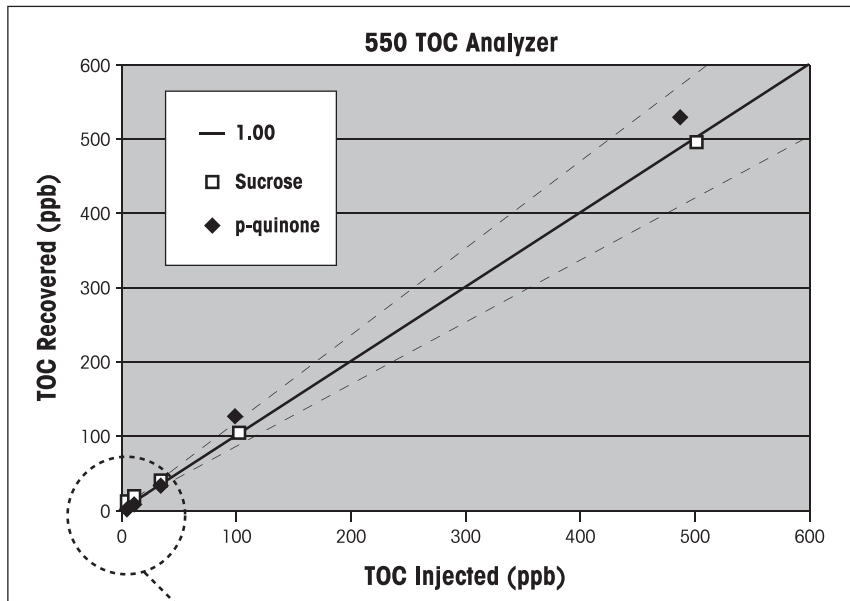

## Specifications

Ambient Temp / Humidity:	5-40 °C / 5-80% RH Non-condensing
Location:	Industrial Environment (Indoor)
Display:	LCD with back-light, displays TOC, resistivity, temperature, and operation/error indications
Analog Outputs:	One 4-20 mA DC, Output is selectable for TOC or resistivity or temperature
Alarm Outputs:	Two SPDT contacts for Hi-Alarm, Lo-Alarm and Error Rated 0.4A @ 120 VAC, 2.0A @ 30 VDC
Alarms Displayed:	UV lamp replacement Alarm; Error Alarm (both on LCD)
Voltage / Current:	100-240 VAC @ 50 / 60 Hz / 50W (max)
Size:	12.8" (327 mm) w x 6.6" (167 mm) h x 13.8" (350 mm) d
Weight:	17.6 lb. (8 kg)
Sample Connections:	0.25" (6 mm) tube fittings
Wetted Parts:	316 SS, PVDF, high quality quartz glass

## Optional

Printer:	Thermal, Serial dot
Print Out:	TOC, Resistivity, Temperature, Date and Time
Printer Interval:	1-99 seconds, 1-99 minutes, 1-99 hours (adjustable in increments of 1)
Power:	7 VDC (provided by analyzer)

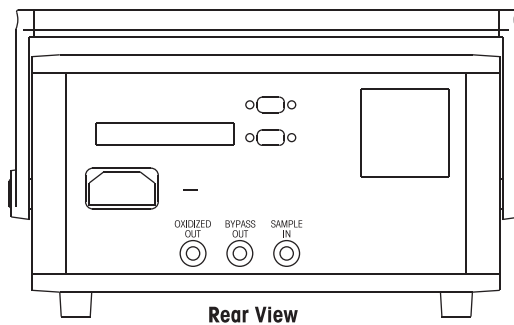
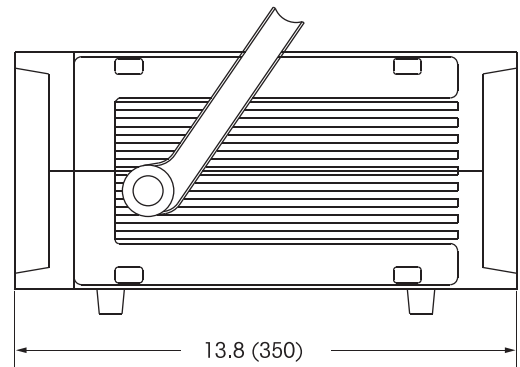
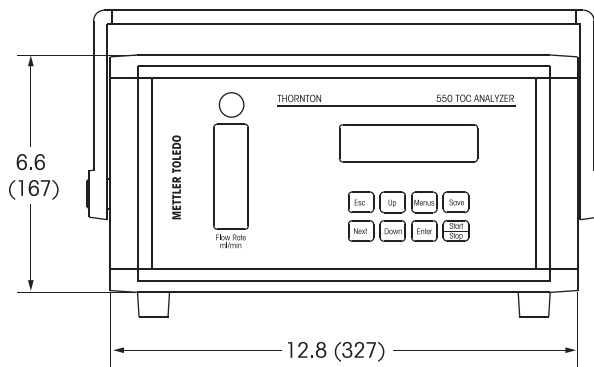

Dimensions: inches (mm).

## Ordering Information

Description	Part No.
550TOC-HT Analyzer 0.1-1000 ppb, (5-90 °C), 100-240 VAC, 50/60 Hz	135-003

## Accessories & Replacement Parts

Description	Part No.
Replacement UV lamp	58079510
Thermal printer, 7 VDC (Includes printer, serial interface cable, power cable and printer manual)	139-003
Resistor set for sensor board calibration	139-005
Validation Support Document Package (CD-ROM)	139-017

## Systems Suitability Standards

Description	Part No.
550TOC System Suitability Test Kit (Includes pump, AC adapter, tubing and carrying case)	139-015
System Suitability Standards Solution Set, including: 1 bottle of 500 ppb System Suitability Solution as 1,4-Benzoquinone, USP (R <sub>SS</sub> ) 1 bottle of 500 ppb Standard Solution as Sucrose, USP (R <sub>S</sub> ) 2 bottles of Reagent Water (R <sub>W</sub> )	139-016

All 550TOC standards solutions are packaged in 1000 mL bottles.

Please contact Thornton Technical Service for more information about the following 550TOC products and services:

- Factory Calibrations with Certificate of Accuracy
- Factory System Suitability Testing with SST Certificate
- Field Installation and Validation support services
- Field System Suitability Test Services with SST Certificate

[www.mt.com/thornton](http://www.mt.com/thornton)

Visit for more information

### Mettler-Toledo Thornton, Inc.

36 Middlesex Turnpike,  
Bedford, MA 01730 USA  
Tel. +1-781-301-8600  
Fax +1-781-301-8701  
Toll-Free: 1-800-510-PURE (US and Canada only)  
thornton.info@mt.com

Subject to technical changes.  
© Mettler-Toledo Thornton, Inc.  
ML0095 Rev.F 4/08



**CSA Certification**  
US and Canadian markets



**Quality certificate.**  
Development, production and testing to ISO 9001.



A certified ServiceXXL provider.



CE Compliant