

**METTLER TOLEDO**  
**IND425 / IND435 / IND445 / IND465 terminals**

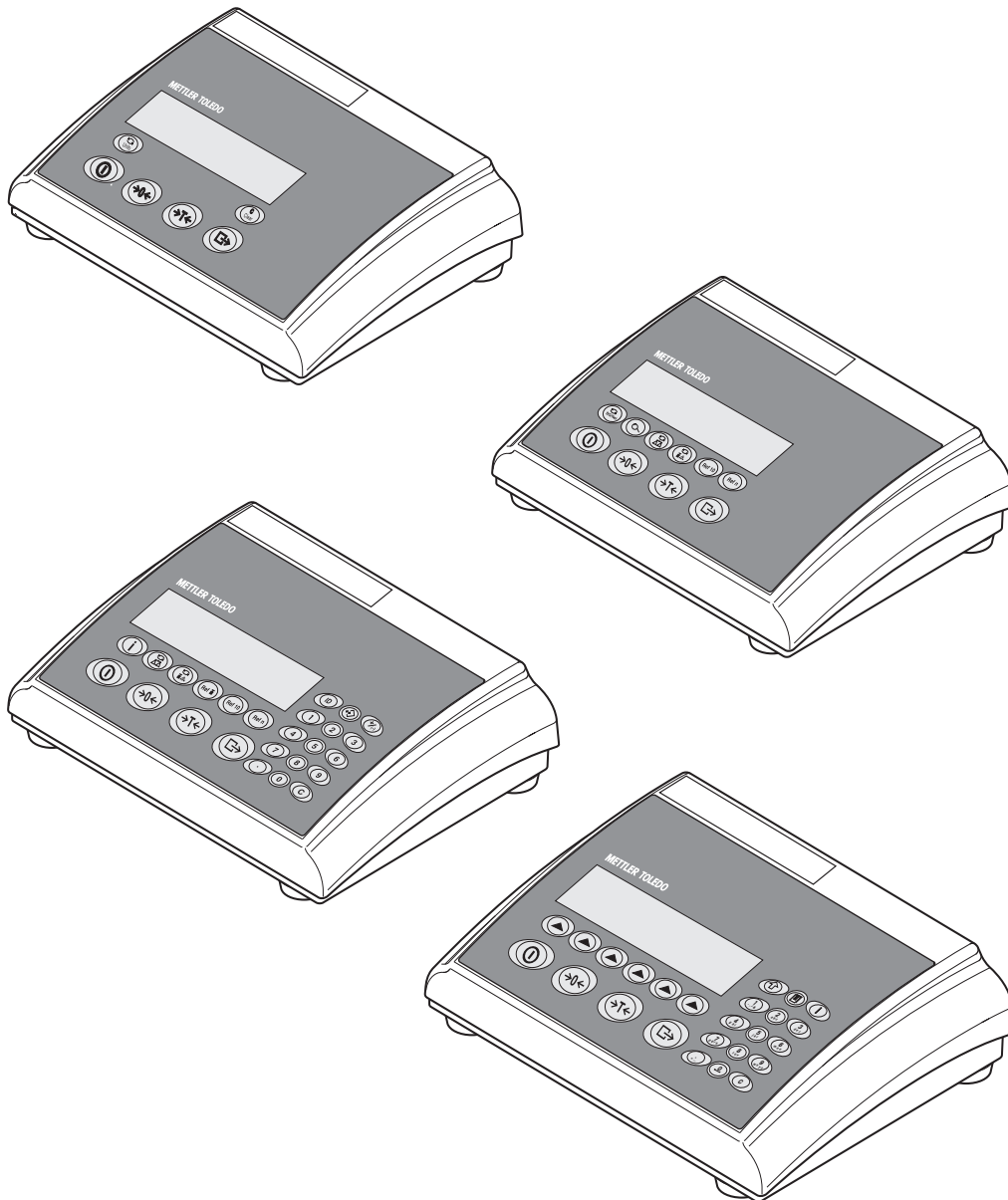

[www.mt.com/support](http://www.mt.com/support)



# Contents

<b>1</b>	<b>Important information .....</b>	<b>4</b>
1.1	Product range .....	4
1.2	Documentation .....	4
1.3	Safety and environment .....	4
<b>2</b>	<b>Attaching weighing platforms .....</b>	<b>5</b>
2.1	Instructions on weighing cells .....	5
2.1.1	Cells with or without SENSE lines .....	5
2.1.2	Attaching weighing platforms with several weighing cells .....	5
2.2	Preparing the connecting cable for the weighing platform .....	5
2.3	Attaching the weighing platform to the terminal .....	6
2.4	Attaching a second weighing platform to the analog option .....	7
<b>3</b>	<b>Configuring the terminal .....</b>	<b>8</b>
3.1	Calling up the menu and entering the password .....	8
3.2	Calling up the service level of certified scales .....	8
3.3	Summary of menu blocks of the service level .....	9
3.4	Admissibility for certification (SCALE → Metrology) .....	10
3.5	Selecting the scale to be configured (SCALE → Scale 1) .....	10
3.6	Calling up the value of the A/D converter (SCALE → Ramp) .....	10
3.7	Serial number of the terminal (SCALE → SNR) .....	10
3.8	Entering the configuration data (SCALE → Scale Build) .....	11
3.8.1	Defining the type of scale (SCALE → Scale Build → Scale Type) .....	11
3.8.2	Setting the basic unit (SCALE → Scale Build → Basic Unit) .....	11
3.8.3	Setting the scale capacity (SCALE → Scale Build → Scale Capacity) .....	12
3.8.4	Selecting the resolution (SCALE → Scale Build → Resolution) .....	12
3.9	Setting the Geo value (SCALE → Geo) .....	12
3.10	Linearization with calibration (SCALE → Lin-Cal) .....	13
3.11	Basic calibration (SCALE → Cal) .....	14
3.12	Activating the control mode (SCALE → Control) .....	14
3.13	Settings for the zero point (SCALE → Zero) .....	14
3.13.1	Setting the zero capturing range (SCALE → Zero → Zero Capture) .....	15
3.13.2	Moving the calibration zero point (SCALE → Zero → Set Zero) .....	15
3.14	Saving the settings and exiting the menu (End) .....	15
<b>4</b>	<b>Table of Geo values .....</b>	<b>16</b>
<b>5</b>	<b>Setting up a weighing system and technical data .....</b>	<b>17</b>
5.1	Selecting the weighing cell(s) .....	17
5.2	Measuring ranges of the IND4.. terminal .....	19
5.3	Technical data .....	20
<b>6</b>	<b>Event and error messages .....</b>	<b>21</b>

# 1 Important information

Please read this installation information carefully and observe all instructions! Please contact the Sales Office if there are items which are missing or have been wrongly delivered, or if you encounter any other problems with the terminal. These instructions are intended for those who have a basic but adequate knowledge of the design of weighing systems.

## 1.1 Product range

The **OptionPac** is a special equipment for the IND4... terminals. It may contain various options such as extra interfaces or battery operation. The OptionPac also has an optional analog interface so that a second weighing platform can be connected. If an OptionPac has been ordered, then this will be fitted with the required options and mounted on the base of the terminal. Other accessories available can be found in the enclosed operating instructions.

## 1.2 Documentation

These instructions only describe the installation of the terminal and its adjustment to the weighing platform to be used. Operating the terminal and adjusting it to operating and process conditions are described in the operating instructions delivered with the terminal.

## 1.3 Safety and environment

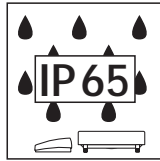

Do not use the terminal in a **hazardous area** (except those versions specially marked for this).

Although the IND4.. terminals have **IP65** protection, they may not be used in areas where there is **risk of corrosion**. The terminal must never be flooded or submerged in liquid!



Before connecting to the power supply, ensure that the local line voltage is the same as the voltage stated on the rear of the scale. If these differ, the terminal must not be connected (please contact your local Sales Office).

If the **power cable** is damaged, then the weighing system should not be operated. The cable must therefore be regularly checked.

Using the Spider terminal in **food processing**: Those parts in contact with foodstuffs have smooth surfaces and are easy to clean. The materials used in their construction do not crack and contain no harmful substances. A **protective** (optional) **cover** is recommended when using the terminal in food processing. This must be cleaned regularly. Damaged or dirty protective covers should be replaced immediately.

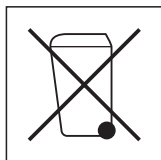

Please note all current environmental directives when **disposing of the terminal**. **Battery-powered** terminals: The battery contains heavy metals and therefore must not be disposed of as normal waste! Please observe local regulations when disposing of environmentally harmful materials.

## 2 Attaching weighing platforms

All analog weighing platforms can be attached to IND4.. terminals if they are conform to the required specifications (see chapter 5). Two different weighing platforms can be attached if the terminal also has an OptionPac with an analog option. Compact two-scale systems can therefore be constructed using just one terminal.

### 2.1 Instructions on weighing cells

#### 2.1.1 Cells with or without SENSE lines

In the case of cells without SENSE lines, the connections "+Ex" (Excitation) and "+Se" (Sense) or "-Ex" and "-Se" must be short-circuited at the connection or the terminal in the OptionPac.

##### Cells without SENSE lines

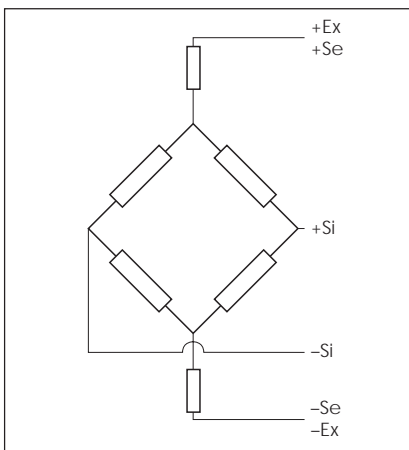

##### Cells with SENSE lines

(required for certifiable weighing systems)

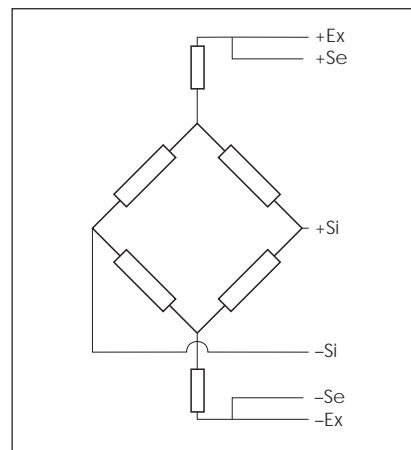

#### 2.1.2 Attaching weighing platforms with several weighing cells

Up to 4 weighing cells can be connected in parallel to a terminal. These weighing cells can be connected in the usual way using a junction box.

The sum of the rated capacities of the individual cells corresponds to the total capacity of the weighing system. When entering the weighing capacities in the menu-driven dialog (chapter 4), the values should be selected so that the individual cells are not overloaded!

### 2.2 Preparing the connecting cable for the weighing platform

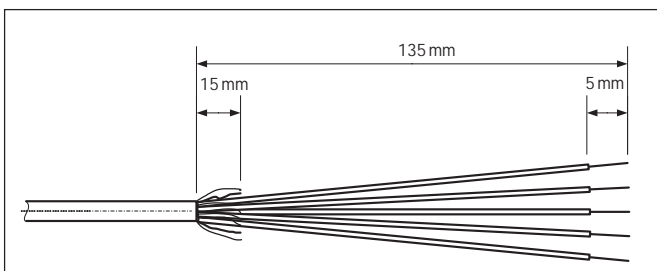

Remove the insulation as shown on the left.

**Note:** For connecting to the analog option, only 100 mm of cable insulation should be removed.

### 2.3 Attaching the weighing platform to the terminal

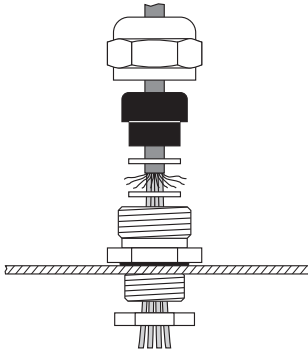

**Before assembling, the terminal must first be disconnected from the power supply!**

Undo the gland nut of the heavy gauge cable gland and remove this together with the black crimping ferrule and the two washers. Undo the rear cover plate of the terminal (6 Torx T20 screws) and fold down carefully (cable connections!).

Mount the nut, crimping ferrule and the washer with the larger hole on the connecting cable of the weighing platform. Flange the shield of the cable slightly and place the second washer over it. Insert the cable through the heavy gauge cable gland of the terminal.

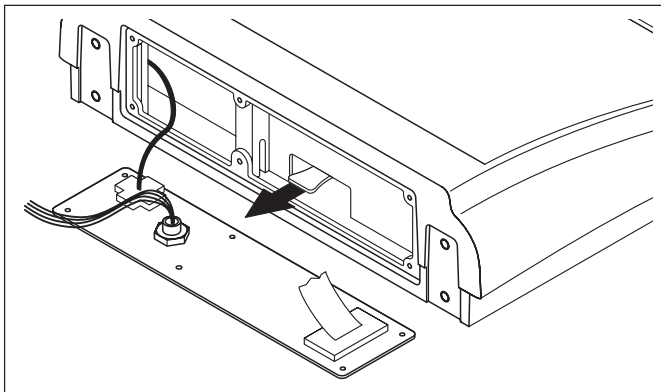

Remove the green plug from the terminal. The plug connector is fitted with a latch to simplify plugging in and out. The diagram opposite shows the position of the connector in the terminal.

Secure the individual strands of the connecting cable on the connector. The pin assignment is shown in the diagram opposite.

The connectors are marked as follows:  
Si = Signal, Ex = Excitation, Se = Sense.

The 7-pin connector also has a terminal for signal ground in the center. The signal ground can be led either to this signal ground terminal or else connected to the shield of the cable (see description and diagram above).

Attach the connector to the terminal. **Caution: When inserting the connector, ensure that it is centered exactly in the connector socket. If the connector is skew, then not all pins are in contact!**

Reassemble the rear cover plate of the terminal. Note that the connecting cable of the weighing platform is not crimped!

Tighten the nut of the heavy gauge cable gland. Ensure that the shield of the cable is held firmly between the two washers.

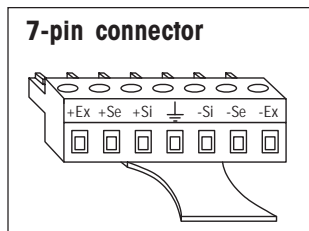

## 2.4 Connection of a second weighing platform to the analog option

The analog option, which allows the connection of a second weighing platform, is housed in the OptionPac. The connection of a second weighing platform to the analog option requires that a weighing platform already be connected to the terminal. The analog second weighing platform is connected directly to the OptionPac via a 9-pin Sub-D connector.

METTLER TOLEDO offers analog weighing platforms that are already equipped with a connector that is suitable for connection to the analog option, so that no installation work is required.

Pin	Assignment
1	+ Excitation (+8,2 VDC)
2	+ Sense
3	Shield
4	– Sense
5	– Excitation
6	not assigned
7	+ Signal
8	– Signal
9	not assigned

### Connection of analog weighing platforms without suitable connector

Connect analog weighing platforms that do not have a suitable connector to the analog option in accordance with the adjacent connection assignment. Also observe the connection assignment of the weighing platform.

**Important:** The analog second weighing platform is configured as a reference scale in the factory setting. "Bulk" (bulk scale) or "Auxiliary" (auxiliary scale) can furthermore be selected in the interface menu "COMMUNICATION -> Option -> Mode". The weighing platform can be deactivated with the "Bypass" setting.

Then calibrate the weighing platform ("SCALE 2").

## 3 Configuring the terminal

The configuration data of the weighing system must be known before the terminal can be configured (see chapter 5). The IND4.. terminal has a service level for entering configuration data as well as for calibrating and linearization of the weighing system. This level is protected by a password. The menus of the service level are used in exactly the same way as those for the operator and for the supervisor (see operating instructions).





### 3.1 Calling up the menu and entering the password

The service level of the menu is protected by a special password (key sequence).

CODE

Press and hold down the  key until the prompt to enter the password appears.

**Note: For certifiable scales, direct access is denied to the service level. In this case, carry out the procedure in chapter 3.2.**

**Immediately** enter the service password    .

SCALE

The first menu block ("SCALE") is shown once the password has been entered.

### 3.2 Calling up the service level of certified scales

Due to metrological regulations, direct access is blocked to the service level of certified or certifiable scales. Carry out the following procedure to call up the service level of such a scale:

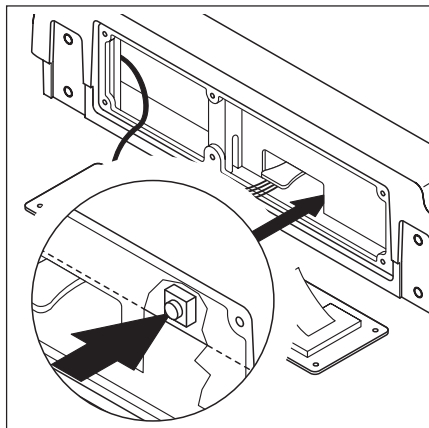

Switch off the terminal (do not isolate from the power supply!).

Undo the rear cover plate of the terminal (6 Torx T20 screws) and fold down carefully (cable connections!).

**Important:** The seal must be broken to remove the rear cover plate. Once the seal is broken, the scale must be recertified by an approved certification center and a new seal applied before it can be used again as a certified scale!

The **service switch** (push button) must first be pressed to call up the service level. This is recessed and located next to the connector for the weighing platform (see opposite figure). Use a suitable object or instrument to press down the switch (the blunt tip of a pencil is recommended). **Note:** Before pressing the service switch, the  switch of battery-operated terminals must first be switched on.

The terminal is switched on by pressing the switch, and the first block of the menu ("SCALE") is shown in the display. All menu blocks of the service level are now accessible.

Reassemble the rear cover plate of the terminal.



### 3.3 Summary of menu blocks of the service level

The complete menu is available including those menu blocks to which operators and supervisors have access. The following summary shows only those **menu blocks of the service level in the menu "SCALE"**. The rest of the menu is described in the operating instructions.

Display	Remarks
<pre> graph TD     SCALE[SCALE] --&gt; METROLO[METROLO]     METROLO --&gt; SCALE1[SCALE 1]     SCALE1 --&gt; SCALE2[SCALE 2]     SCALE2 --&gt; RAMP[RAMP]     RAMP --&gt; SNR[SNR]     SNR --&gt; SCAL_bLd[SCAL.bLd]     SCAL_bLd --&gt; GEO[GEO]     GEO --&gt; LIN_CAL[LIN - CAL]     LIN_CAL --&gt; CAL[CAL]     CAL --&gt; CONTROL[CONTROL]     CONTROL --&gt; ZERO[ZERO]     ZERO -.-&gt; SCALE           </pre>	<p><b>Service level in menu block "SCALE":</b></p> <p>Determining the admissibility for certification —&gt; chapter 3.4</p> <p>Selecting the scale to be configured (for two-scale system only, i.e. blocks only appear if an analog option is available) —&gt; chapter 3.5</p> <p>Display of deflection of A/D converter ("ramp") —&gt; chapter 3.6</p> <p>Calling up/changing the serial number —&gt; chapter 3.7</p> <p>Entering the configuration data —&gt; chapter 3.8</p> <p>Setting the Geo value —&gt; chapter 3.9</p> <p>Linearization with calibration —&gt; chapter 3.10</p> <p>Basic calibration —&gt; chapter 3.11</p> <p>Activating the control mode —&gt; chapter 3.12</p> <p>Settings for the zero point —&gt; chapter 3.13</p>

#### Navigating the menu:

In the following section, the arrows indicate how to operate the menu:

- Pressing the key ("YES")
- Pressing the key ("NO")
- Pressing the key jumps to the end of the menu ("End")
- Pressing the key jumps backwards through the menu

### 3.4 Admissibility for certification (SCALE → Metrology)

Display	Remarks
	<p>Setting the admissibility for certification:</p> <p>Scale not certifiable.</p> <p>Scale certifiable to OIML.</p> <p><b>Caution:</b> When a scale is declared certifiable, then certain settings are no longer available. Direct access to the menu for the service technician is also blocked (see chapter 3.2)!</p>

### 3.5 Selecting the scale to be configured (SCALE → Scale 1)

Display	Remarks
	<p>This option is only available for two-scale systems, i.e. the terminal is fitted with an analog option for connecting to a second weighing platform and the analog interface is activated (see chapter 2.4)!</p> <p>Scale 1 should be configured.</p> <p>Scale 2 (connected to the analog option) should be configured.</p> <p>Identical menu blocks are available in the service level for both scales. These are described in the following chapters.</p>

### 3.6 Calling up the value of the A/D converter (SCALE → Ramp)

Display	Remarks
	<p>Displaying the analog/digital converter deflection ("ramp") as a percentage.</p> <p>This value determines whether the weighing cell is operating correctly. Scales with identical and correctly functioning weighing cells have roughly the same ramp value. This value is dynamic and changes as the load itself changes.</p>

### 3.7 Serial number of the terminal (SCALE → SNR)

Display	Remarks
	<p>Displaying or changing the serial number of the terminal. Note: The number should be changed or re-entered only when necessary (e.g. after installing a new terminal board).</p> <p>For IND445 / 465 terminals, the serial number can be entered via the numeric keyboard. For IND425 / 435 terminals, press the <math>\rightarrow T \leftarrow</math> key. The first digit flashes and can now be changed using the <math>\rightarrow T \leftarrow</math> and <math>\rightarrow 0 \leftarrow</math> keys. Confirm the new digit with the <math>\rightarrow \leftarrow</math> key. The second digit now flashes and can be changed in the same way. This same procedure is used for all digits (total of 7 digits).</p>

### 3.8 Entering the configuration data (*SCALE* → *Scale Build*)

Display	Remarks
<pre> graph TD     SCAL_bLd[SCAL.bLd] --&gt; SCAL_tYP[SCAL.tYP]     SCAL_tYP --&gt; bAS_UNIt[bAS.UNIt]     bAS_UNIt --&gt; SCL_CAP[SCL.CAP]     SCL_CAP --&gt; RESOL[RESOL.]     RESOL --&gt; SCAL_bLd           </pre>	<p><b>Entering configuration data</b></p> <p>Defining the type of scale → chapter 3.8.1</p> <p>Specifying the basic units → chapter 3.8.2</p> <p>Specifying the capacity of the weighing system → chapter 3.8.3</p> <p>Selecting the resolution → chapter 3.8.4</p>

#### 3.8.1 Defining the type of scale (*SCALE* → *Scale Build* → *Scale Type*)

Display	Remarks
<pre> graph TD     SCAL_tYP[SCAL.tYP] --&gt; SINGLE_R[SINGLE.R]     SINGLE_R --&gt; 2MULT_IN[2MULT.IN]     2MULT_IN --&gt; 2MULT_RN[2MULT.RN]     2MULT_RN --&gt; 3MULT_IN[3MULT.IN]     3MULT_IN --&gt; 3MULT_RN[3MULT.RN]     3MULT_RN --&gt; SCAL_tYP           </pre>	<p>Defining the scale type</p> <p>"Single Range": for the single range scale.</p> <p>"Multi Intervall": scale with one coarse range and 1 movable fine range. Automatic switching between ranges in both directions.</p> <p>"MultiRange": scale with one coarse range and 1 fixed fine range. Automatic switching to the coarse range. Returning to the fine range on reaching zero.</p> <p>"Multi Intervall" scale with a coarse range and 2 movable fine ranges.</p> <p>"MultiRange" scale with one coarse range and 2 fixed fine ranges.</p>

#### 3.8.2 Setting the basic unit (*SCALE* → *Scale Build* → *Basic Unit*)

Display	Remarks
<pre> graph TD     bAS_UNIt[bAS.UNIt] --&gt; g[g]     g --&gt; kg[kg]     kg --&gt; oz[oz]     oz --&gt; lb[lb]     lb --&gt; t[t]     t --&gt; bAS_UNIt           </pre>	<p>Setting the basic unit for entries in the service level.</p> <p>Gram</p> <p>Kilogram</p> <p>Ounce</p> <p>Pound</p> <p>Metric ton</p>

### 3.8.3 Setting the scale capacity (SCALE → Scale Build → Scale Capacity)

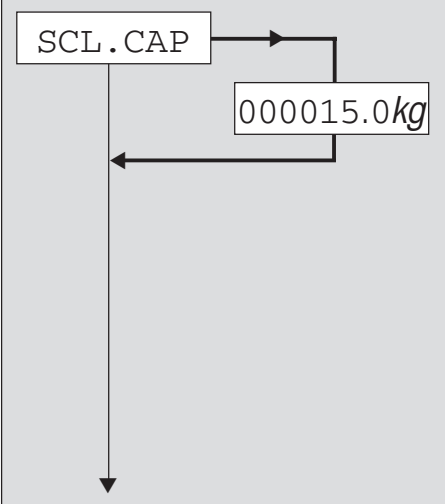
Display	Remarks
	<p>Entering the scale capacity (in the preset basic unit).</p> <p>For IND445 / 465 terminals, the capacity can be entered via the numeric keyboard.</p> <p>For IND425 / 435 terminals, press the <math>\rightarrow T \leftarrow</math> key. The first digit flashes and can now be changed using the <math>\rightarrow T \leftarrow</math> and <math>\rightarrow 0 \leftarrow</math> keys. Confirm the new digit with the <math>\leftarrow \rightarrow</math> key. The second digit now flashes and can be changed in the same way. This same procedure is used for all digits (total of 7 digits).</p> <p>For a <b>multirange scale</b> (see chapter 3.8.1), this block is separately available for each weighing range ("SCL.CAP 1" to "SCL.CAP 3", depending on the number of ranges). The additional blocks for capacity are each shown after the block for "Resolution". The upper limit is entered for each weighing range. Example when using a 30 kg dual-range scale: "SCL.CAP 1" = 15 kg, "SCL.CAP 2" = 30 kg. In this example, the ranges switch over from fine to coarse at 15 kg.</p>

### 3.8.4 Selecting the resolution (SCALE → Scale Build → Resolution)

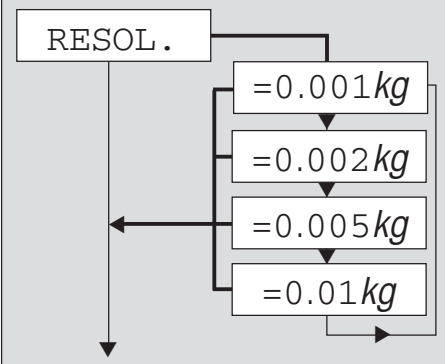
Display	Remarks
	<p>Selecting the resolution (in the preset basic unit).</p> <p>The resolutions available depend on the capacity of the scale system. The diagram opposite provides an example.</p> <p>For a multirange scale (see chapter 3.8.1), this block is separately available for each weighing range ("RESOL. 1" to "RESOL. 3", depending on the number of ranges). The additional blocks for resolution are each shown after the appropriate block for entering the capacity ("SCL.CAP 1" to "SCL.CAP 3").</p>

### 3.9 Setting the Geo value (SCALE → Geo)

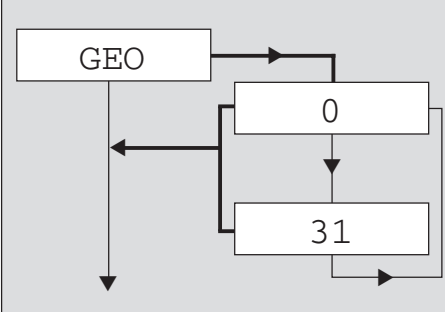
Display	Remarks
	<p>Setting the Geo value.</p> <p>With the Geo value, the scale system can be adjusted to local gravitational conditions. This value can be altered by pressing the <math>\rightarrow T \leftarrow</math> and <math>\rightarrow 0 \leftarrow</math> keys (range 0 – 31). The table for Geo values is given in chapter 4.</p>

### 3.10 Linearization with calibration (*SCALE* → *Lin-Cal*)

Display	Remarks
<pre> graph TD     LIN_CAL[LIN - CAL] --- V1[ ]     V1 --&gt; 3_POINT[3 POINT]     V1 --&gt; 5_POINT[5 POINT]     3_POINT --&gt; 5_POINT     3_POINT --&gt; Z0["- 0 -"]     5_POINT --&gt; Z0     Z0 --- DOTS1[...]     DOTS1 --- 15kg["15.000kg"]     15kg --&gt; 12kg["12.000kg"]     12kg --&gt; 4kg["4.000kg"]     4kg --&gt; 15kg     15kg --- DOTS2[...]     DOTS2 --- done[done]     done --&gt; V1     V1 --&gt; END[ ]   </pre>	<p>Linearizing the scale system with simultaneous calibration. Calibration is carried out purely theoretically to compensate for shifts in the full load when linearizing. The loads applied are checked (<math>\pm 5\%</math>) and thus a basic calibration must first be carried out (chapter 3.11).</p> <p>Apply preload, if applicable, then select the type of linearization/calibration and confirm with the  key:</p> <ul style="list-style-type: none"> <li>– 3-point linearization (standard for 0%, 50% and 100% of the full load).</li> <li>– 5-point linearization (standard for 0%, 25%, 50%, 75% and 100% of the full load).</li> </ul> <p>After confirming the type of linearization, the display flashes while the scale automatically determines the zero point. This zero point determination can be skipped by pressing the  key in which case the existing zero point is used as the reference point. This is especially useful for a large scale if test weights have already been applied and which must be removed in order to determine the zero point.</p> <p>The scale prompts for a weight (half load for 3-point linearization or quarter load for 5-point linearization). Change weight, if desired (values available depend on the capacity of the weighing system).</p> <p>By applying the weight and confirming with the  key, the first point is thus linearized. The scale then prompts for other weights (the number of weights depends on the type of linearization selected), which may be changed as required. At the last linearization point, the scale is also calibrated. The linearization/calibration can be exited at any time by pressing the  key.</p> <p>The scale indicates that the linearization/calibration procedure is completed once all points have been linearized.</p>

### 3.11 Basic calibration (SCALE → Cal)

Display	Remarks
<pre> graph TD     CAL --&gt; PRELOAD     PRELOAD --&gt; 6kg[6.000kg]     6kg --&gt; 5kg[5.000kg]     5kg --&gt; 6kg     6kg --&gt; 2kg[2.000kg]     2kg --&gt; 6kg     6kg --&gt; doneE[donE]     </pre>	<p>The basic calibration corresponds to the calibration function for the user (however, the user cannot set the preload).</p> <p>Apply the preload and confirm with the <b>↵</b> key. If a test weight is already on the scale, the preload measurement can be skipped by pressing the <b>↵</b> key. The existing zero point is then used as the reference point. This is especially useful for a large scale if test weights have already been applied and which must be removed in order to determine the preload.</p> <p>The scale prompts for a calibration weight corresponding to the nominal capacity of the weighing system.</p> <p>Change calibration weight, if desired (values available depend on the capacity of the weighing system).</p> <p>Apply the selected weight and confirm with the <b>↵</b> key. (The calibration can be exited at any time by pressing the <b>⏏</b> key).</p> <p>Calibration is completed.</p>

### 3.12 Activating the control mode (SCALE → Control)

Display	Remarks
<pre> graph TD     CONTROL --&gt; 7.246     7.246 --&gt; CONTROL     </pre>	<p>Activating the control mode.</p> <p>The control mode displays the current weighing result at high resolution (but without weighing unit). This enables the scale, for example, to be checked after calibration and/or linearization.</p>

### 3.13 Settings for the zero point (SCALE → Zero)

Display	Remarks
<pre> graph TD     ZERO --&gt; ZCAPt[Z - CAPt]     ZCAPt --&gt; SEtZERO[SEt.ZERO]     SEtZERO --&gt; AZM[AZM]     AZM --&gt; ZERO     </pre>	<p><b>Settings for the zero point</b></p> <p>Setting the zero capturing range → chapter 3.13.1</p> <p>Moving the calibration zero point → chapter 3.13.2</p> <p>This menu block also includes the block for automatic zero point correction. It is also available to the user and is thus not described here (see operating instructions).</p>

### 3.13.1 Setting the zero capturing range (*SCALE* → *Zero* → *Zero Capture*)

Display	Remarks
<pre> graph TD     ZCAP[Z - CAPt] --&gt; Z18["- 2 18"]     ZCAP --&gt; Z2["- 2 2"]     Z18 --&gt; Arrow1[↓]     Z2 --&gt; Arrow2[↓]     Z2 --&gt; Z18   </pre>	<p>Setting the zero capturing range (when switching on and via the <math>\rightarrow 0 \leftarrow</math> key).</p> <p>Zero capturing range <math>-2\%</math> to <math>+18\%</math></p> <p>Zero capturing range <math>-2\%</math> to <math>+2\%</math> (mainly for certifiable scales)</p> <p>The zero capturing range is set at the expense of the nominal capacity of the scale. If the capacity of the scale should be fully used, then the zero capturing range can be reduced to <math>-2\%</math> to <math>+2\%</math>.</p>

### 3.13.2 Moving the calibration zero point (*SCALE* → *Zero* → *Set Zero*)

Display	Remarks
<pre> graph TD     SetZero[Set . ZERO] --&gt; Arrow1[↓]     SetZero --&gt; SURE[SURE?]     SURE --&gt; Arrow2[↓]     SURE --&gt; SetZero   </pre>	<p>Moving the calibration zero point is required: when an auxiliary preload is used or the scale cannot be calibrated with the current preload (e.g. roller track) because the values are outside the zero capturing range (in this case, the scale cannot be started). The appropriate preload must be applied to the scale in order to carry out a "Set Zero". The zero point for calibration by the user is moved to the new value, as is the zero capturing range.</p> <p>Carry out or cancel moving of the calibration zero point.</p> <p>If, after exiting the menu, the display indicates underload or overload, the terminal should be switched off and on again.</p>

### 3.14 Saving the settings and exiting the menu (*End*)

Display	Remarks
<pre> graph TD     End[End] --&gt; Arrow1[↓]     End --&gt; SAVE[SAVE]     SAVE --&gt; Arrow2[↓]     SAVE --&gt; End     End --&gt; Zero[0.00kg]   </pre>	<p>This menu block is entered directly from any point in the menu by pressing the <math>\text{D}</math> key!</p> <p>Save modified settings by pressing the <math>\text{E} \rightarrow</math> key or discard them by pressing the <math>\text{T} \leftarrow</math> key.</p> <p>The scale returns to weighing mode.</p>

## 4 Table of Geo values

Northern or southern geographical latitude in degrees and minutes	Height above sea level in meters										
	0	325	650	975	1300	1625	1950	2275	2600	2925	3250
	325	650	975	1300	1625	1950	2275	2600	2925	3250	3575
	Height above sea level in feet										
0	1060	2130	3200	4260	5330	6400	7460	8530	9600	10660	
1060	2130	3200	4260	5330	6400	7460	8530	9600	10660	11730	
0° 0' - 5° 46'	5	4	4	3	3	2	2	1	1	0	0
5° 46' - 9° 52'	5	5	4	4	3	3	2	2	1	1	0
9° 52' - 12° 44'	6	5	5	4	4	3	3	2	2	1	1
12° 44' - 15° 6'	6	6	5	5	4	4	3	3	2	2	1
15° 6' - 17° 10'	7	6	6	5	5	4	4	3	3	2	2
17° 10' - 19° 2'	7	7	6	6	5	5	4	4	3	3	2
19° 2' - 20° 45'	8	7	7	6	6	5	5	4	4	3	3
20° 45' - 22° 22'	8	8	7	7	6	6	5	5	4	4	3
22° 22' - 23° 54'	9	8	8	7	7	6	6	5	5	4	4
23° 54' - 25° 21'	9	9	8	8	7	7	6	6	5	5	4
25° 21' - 26° 45'	10	9	9	8	8	7	7	6	6	5	5
26° 45' - 28° 6'	10	10	9	9	8	8	7	7	6	6	5
28° 6' - 29° 25'	11	10	10	9	9	8	8	7	7	6	6
29° 25' - 30° 41'	11	11	10	10	9	9	8	8	7	7	6
30° 41' - 31° 56'	12	11	11	10	10	9	9	8	8	7	7
31° 56' - 33° 9'	12	12	11	11	10	10	9	9	8	8	7
33° 9' - 34° 21'	13	12	12	11	11	10	10	9	9	8	8
34° 21' - 35° 31'	13	13	12	12	11	11	10	10	9	9	8
35° 31' - 36° 41'	14	13	13	12	12	11	11	10	10	9	9
36° 41' - 37° 50'	14	14	13	13	12	12	11	11	10	10	9
37° 50' - 38° 58'	15	14	14	13	13	12	12	11	11	10	10
38° 58' - 40° 5'	15	15	14	14	13	13	12	12	11	11	10
40° 5' - 41° 12'	16	15	15	14	14	13	13	12	12	11	11
41° 12' - 42° 19'	16	16	15	15	14	14	13	13	12	12	11
42° 19' - 43° 26'	17	16	16	15	15	14	14	13	13	12	12
43° 26' - 44° 32'	17	17	16	16	15	15	14	14	13	13	12
44° 32' - 45° 38'	18	17	17	16	16	15	15	14	14	13	13
45° 38' - 46° 45'	18	18	17	17	16	16	15	15	14	14	13
46° 45' - 47° 51'	19	18	18	17	17	16	16	15	15	14	14
47° 51' - 48° 58'	19	19	18	18	17	17	16	16	15	15	14
48° 58' - 50° 6'	20	19	19	18	18	17	17	16	16	15	15
50° 6' - 51° 13'	20	20	19	19	18	18	17	17	16	16	15
51° 13' - 52° 22'	21	20	20	19	19	18	18	17	17	16	16
52° 22' - 53° 31'	21	21	20	20	19	19	18	18	17	17	16
53° 31' - 54° 41'	22	21	21	20	20	19	19	18	18	17	17
54° 41' - 55° 52'	22	22	21	21	20	20	19	19	18	18	17
55° 52' - 57° 4'	23	22	22	21	21	20	20	19	19	18	18
57° 4' - 58° 17'	23	23	22	22	21	21	20	20	19	19	18
58° 17' - 59° 32'	24	23	23	22	22	21	21	20	20	19	19
59° 32' - 60° 49'	24	24	23	23	22	22	21	21	20	20	19
60° 49' - 62° 9'	25	24	24	23	23	22	22	21	21	20	20
62° 9' - 63° 30'	25	25	24	24	23	23	22	22	21	21	20
63° 30' - 64° 55'	26	25	25	24	24	23	23	22	22	21	21
64° 55' - 66° 24'	26	26	25	25	24	24	23	23	22	22	21
66° 24' - 67° 57'	27	26	26	25	25	24	24	23	23	22	22
67° 57' - 69° 35'	27	27	26	26	25	25	24	24	23	23	22
69° 35' - 71° 21'	28	27	27	26	26	25	25	24	24	23	23
71° 21' - 73° 16'	28	28	27	27	26	26	25	25	24	24	23
73° 16' - 75° 24'	29	28	28	27	27	26	26	25	25	24	24
75° 24' - 77° 52'	29	29	28	28	27	27	26	26	25	25	24
77° 52' - 80° 56'	30	29	29	28	28	27	27	26	26	25	25
80° 56' - 85° 45'	30	30	29	29	28	28	27	27	26	26	25
85° 45' - 90° 00'	31	30	30	29	29	28	28	27	27	26	26



## 5 Setting up a weighing system and technical data

Before setting up a weighing system with the IND4.. terminal, its basic data must first be determined. These data are to be entered into the service level of the menu (chapter 3). The typical procedure for setting up a scale system is shown below as follows.

### 5.1 Selecting the weighing cell(s)

The following data must be known in order to determine the capacity of the weighing cell:

- **Scale capacity:** This generally corresponds to the heaviest load that is to be weighed with the weighing system.
- **Preload:** This is the total weight of all parts applied to the weighing cell. This includes the upper part of the weighing platform, the weighing pan and all other components such as a roller track, a fixed weighing container, etc.
- **Total zero setting range:** This consists of the switch-on zero setting range (+18/-2% or  $\pm 2\%$ , selected in the menu) and the zero setting range (2%) that the user has available with the  $\rightarrow 0 \leftarrow$  key. The total zero setting range is thus either 20% or 4% of the weighing capacity.

The sum of the weighing capacity, preload and total zero setting range thus gives the total capacity of the weighing cell required. An additional safety margin should also be included in order to prevent weighing cells from being overloaded.

$$\text{Total capacity of weighing cell(s)} = \text{scale capacity} + \text{preload} + \text{total zero setting range} + \text{safety margin}$$

For **systems with several weighing cells**, the total theoretical capacity is divided by the number of cells (max. 4) in order to determine the capacity of the individual cell. A sufficient safety margin is especially important if the scale is heavily loaded in the cornerload range so that the load is no longer evenly distributed over all cells.

For **systems with lever mechanisms**, the total theoretical capacity is divided by the transmission ratio of the lever system in order to determine the capacity of the cell.

When selecting the weighing cell(s), other parameters are also to be taken into account. These include:

- the smallest display step desired
- requirements for admissibility for certification
- number and type of weighing ranges

The terminal supplies a **voltage** of 8.2 V to the weighing cell(s). The **maximum weighing signal** is determined by multiplying the power supply voltage by the sensitivity of the weighing cell:

Sensitivity of the cell	2 mV/V	3 mV/V
Power supply voltage	8.2 V	8.2 V
Max. weighing signal <sup>1)</sup>	16.4 mV	24.6 mV <sup>1)</sup>
Min. weighing signal per display step (for certifiable scales)	0.5 $\mu$ V/e	0.5 $\mu$ V/e

<sup>1)</sup> Only 20 mV measurable by the A/D converter, so that scale capacity is only max. 81% of the cell capacity.

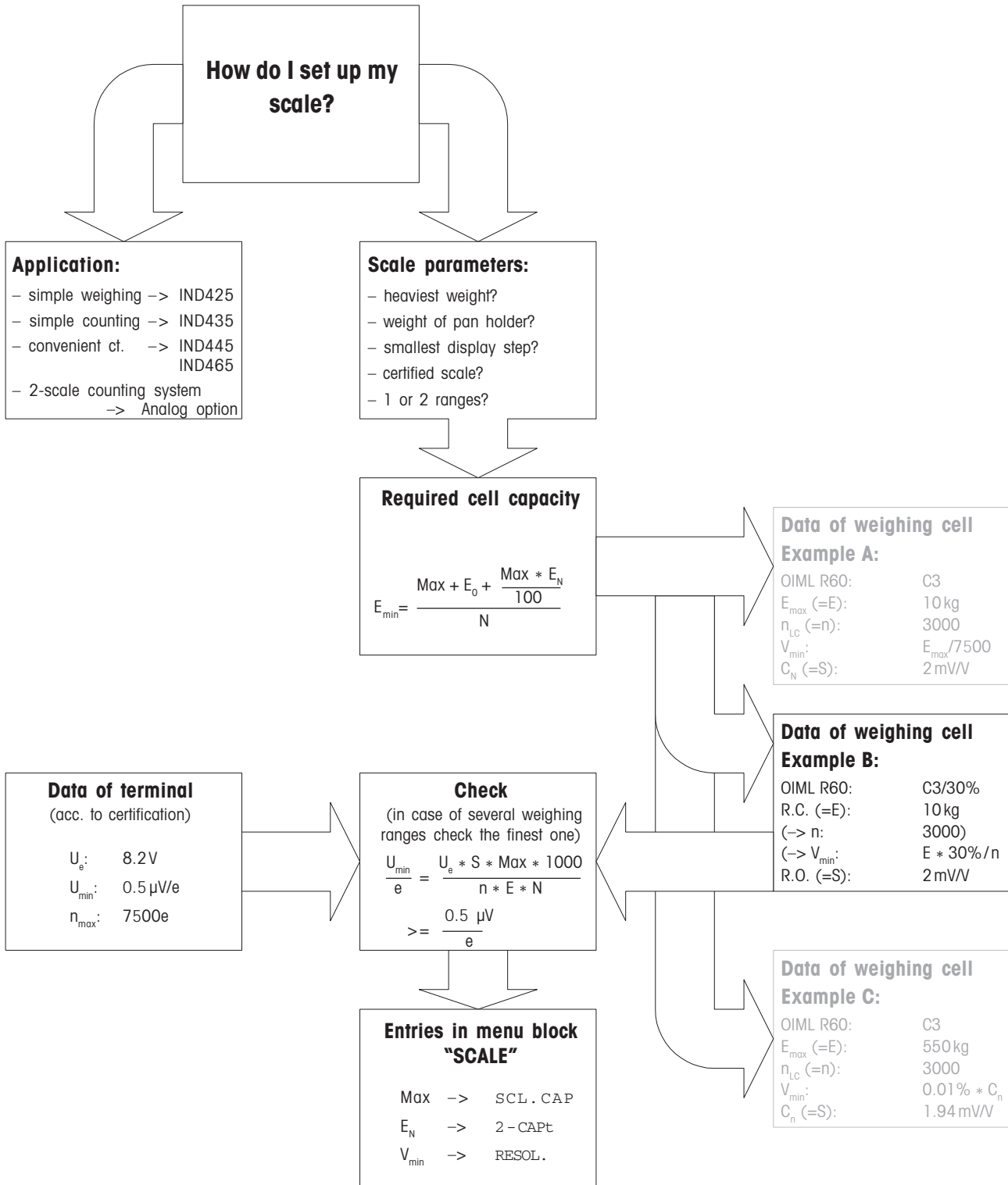

**Key:**

- |                 |   |                         |   |
|-----------------|---|-------------------------|---|
| Max [kg]:       | weighing range  | $U_e$ [V]:              | power supply from terminal                |
| N:              | no. of weighing cells   | S [mV/V]:               | cell output signal                        |
| $E_0$ [kg]:     | preload (weight of pan holder, container, etc.)                                       | n [e]:                  | resolution                                |
| $E_N$ [%]:      | zero setting range (2%) + zero capturing range<br>(+18/-2% or $\pm 2\%$ ) = 20% or 4% | E [kg]:                 | load capacity of selected weighing cell   |
| $E_{min}$ [kg]: | required load capacity per weighing cell  | $U_{min}$ [ $\mu$ V/e]: | minimum voltage per verification interval |
|                 |   | $n_{max}$ [e]:          | maximum resolution                        |
|                 |   | $V_{min}$ [g]:          | display step                              |

## 5.2 Measuring ranges of the IND4.. terminal

When setting up a weighing system, consider the measuring ranges of the IND4.. terminal according to the summary given below.

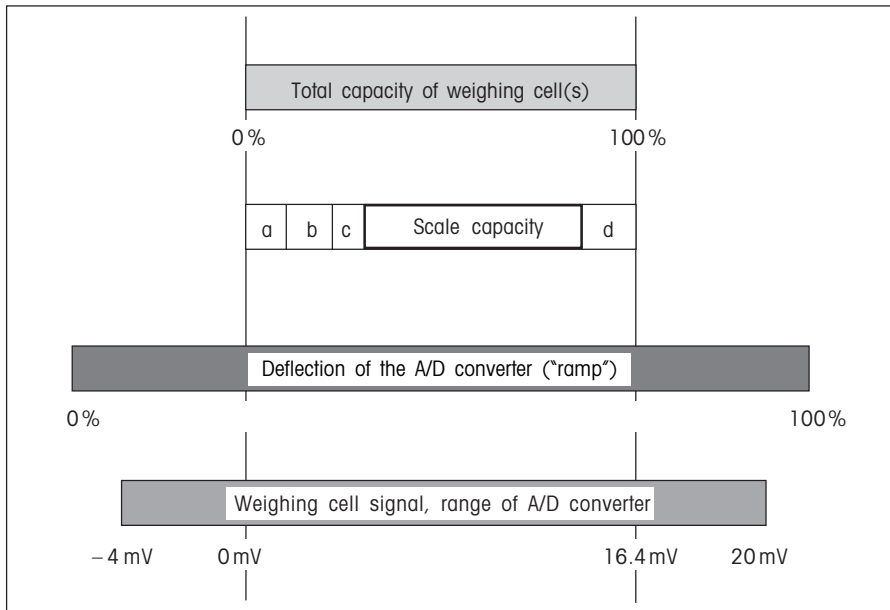

- a:** Total preload applied to weighing cell when calibrating (upper part of platform, weighing pan, roller track, etc.)
- b:** Switch-on zero capturing range: +18/-2% or  $\pm 2\%$  of weighing capacity (menu option)
- c:** Zero setting range with  $\rightarrow 0 \leftarrow$  key:  $\pm 2\%$  of weighing capacity (fixed)
- d:** Safety margin

### 5.3 Technical data

Only those specifications needed for using this installation information are shown below. The other technical data are given in the operating instructions.

Data for the terminal	
Resolution	300 000 points for non-certifiable applications 7 500 points for certifiable applications
Weighing ranges	Up to 3 weighing ranges defined in the menu, incl. movable or fixed fine ranges. For certifiable/certified applications, the minimum voltage per verification scale interval (0.5 µV/e) must be maintained or the resolution must not exceed 7 500e.
Calibration	Basic calibration and calibration during linearization
Linearization	3-point or 5-point with simultaneous calibration
Zero setting range (↔0↔ key)	2% of max. defined useful load, cannot be altered
Autozero range	2% of max. defined useful load, cannot be altered
Switch-on zero setting range	-2% ... 18% or -2% ... 2% of max. defined useful load (menu option)
Linearity	0.01% of the max. defined useful load
Units	g, kg, lb, oz, t
Display steps	1, 2, 5 x 10 <sup>n</sup> (menu option)
Cell power supply	8.2V
Scope of delivery	Terminal with power cable and local connector Installation information for Spider terminal and operating instructions for Spider scale Options: OptionPac with integrated analog option and other options
Requirements for the weighing cell	
Nominal load	0.1 ... 999 999.9 (g, kg, lb, oz, t)
Admissible impedance	80 Ohm ... 1000 Ohm Measure between Si+ and Si- or Ex+ and Ex- while weighing cell is disconnected
Differential signal	-1 mV ... 25 mV (see example below)

#### Example for calculating the differential signal:

Data of the weighing cell: sensitivity of 2 mV/V and cell capacity of 100 kg

Calculating the **differential signal for nom. load** (60 kg):  $2 \text{ mV/V} \cdot 8.2 \text{ V} \cdot 60 \text{ kg}/100 \text{ kg} = 9.84 \text{ mV}$

Calculating the **differential signal for half load** (30 kg):  $2 \text{ mV/V} \cdot 8.2 \text{ V} \cdot 30 \text{ kg}/100 \text{ kg} = 4.92 \text{ mV}$

#### Requirements for certifiable scales

- Certifiable weighing cell with SENSE lines (6 wires), sensitivity of the cell of 2 mV/V or 3 mV/V.
- The scale must be configured in the service level of the menu as certifiable (see chapter 3).
- Approved markings from the manufacturer (if the complete scale is not supplied by METTLER TOLEDO).

## 6 Event and error messages

**Overload:** Reduce the load on the scale or reduce the preload.

**Underload:** Place the weighing pan on the scale and ensure it can move freely.

**Result not stable:** Always appears when not stable (when zeroing, taring, etc.). If the scale still does not become stable after a long time, check the environmental conditions. If necessary, change the setting of the vibration adapter or use the dynamic weighing function.

**Function not allowed:** The requested function cannot be executed because it is not allowed at the time of the request.

**Zeroing not possible:** Make sure that zeroing is being performed in the allowed range and not with overload or underload. Note: The message also appears if it is attempted to tare certified scales with minus values (this is not allowed).

**Reference weight too low:** The weight on the pan is too low to use as a valid reference for piece counting. Place a larger number of reference pieces on the weighing pan.

**No valid value from reference scale:** Only occurs when piece counting on a 2-scale system. Check cable connecting the scales and check interface settings.

**Not calibrated/adjusted:** Disconnect the power supply plug and reconnect it (or if the scale is battery-operated, switch it off and then on again). If the message appears again, calibrate/adjust the scale.

**Reference piece weight too low:** When determining the reference, the resulting weight of a single piece is below the allowable limit. Piece counting is not possible for such pieces.

**Unstable weight value when determining reference:** When determining the reference for piece counting, the weight value did not become stable and the scale cannot determine the reference piece weight. Check the environmental conditions. If necessary, change the setting of the vibration adapter.

**Input error for target value or tolerances:** The value entered is invalid, enter another value.

**Setting the reference piece weight is not allowed:** Do not define a reference piece weight while a weight totaling is in process.

**Switching over the weighing unit is not allowed (totaling):** Do not switch over the weighing unit while a weight totaling is in process.

**Printout not yet complete:** Repeat the desired action after the current printout is complete.

**Changing the weighing unit not allowed (dynamic weighing):** Do not change the weighing unit while you are dynamic weighing.

**EAROM checksum error:** Disconnect the power supply plug and reconnect it (or if the scale is battery-operated, switch the scale off and then on again). If the message re-appears, press the key continuously. The display shows "Flush" and then the scale is restarted. After start-up, the scale shows "Error 6" (missing calibration data). All scale data must be re-entered and the scale recalibrated.



**22011473B**

Subject to technical changes © Mettler-Toledo (Albstadt) GmbH 05/08 Printed in Germany 22011473B

**Mettler-Toledo (Albstadt) GmbH**

D-72458 Albstadt

Tel. ++49-7431-14 0, Fax ++49-7431-14 232

Internet: <http://www.mt.com>