

Pipette Calibration Balance

XPE26PC

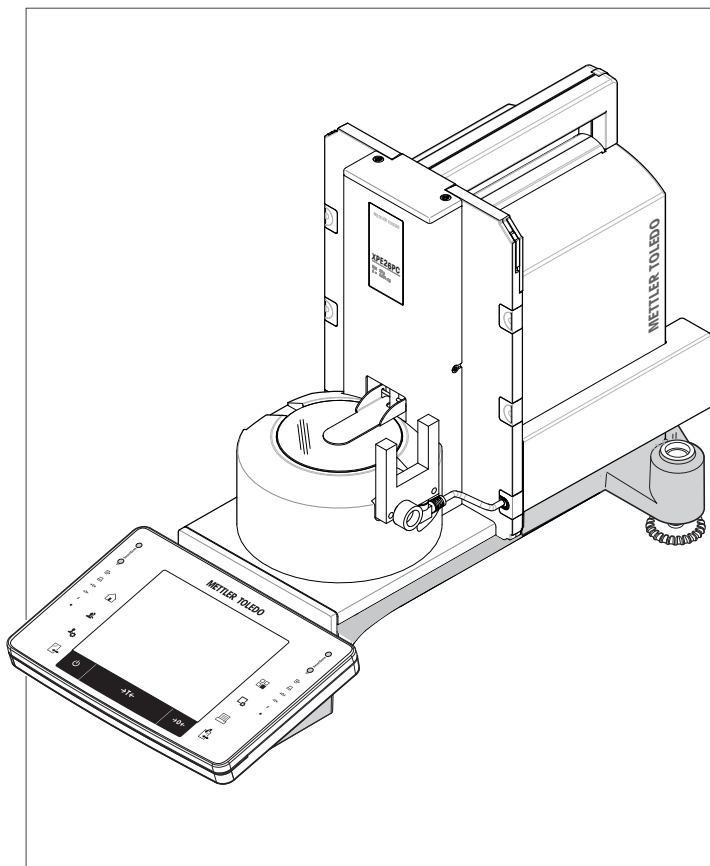

METTLER TOLEDO

Overview Balance

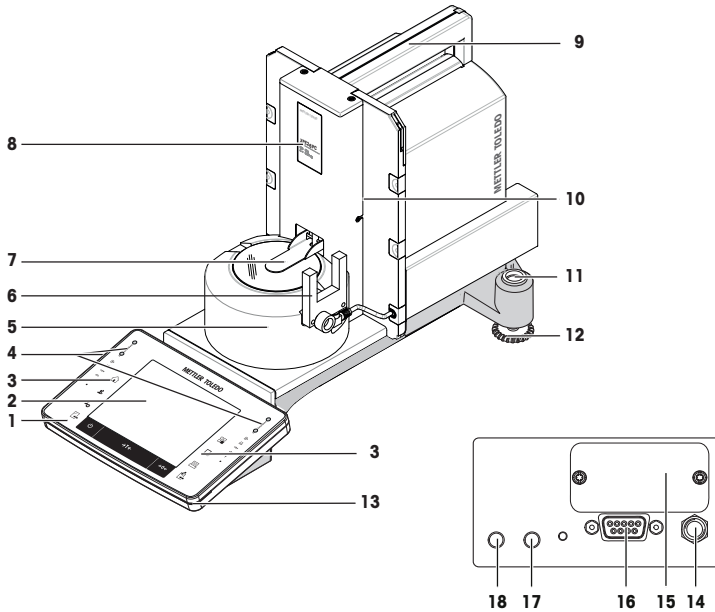

Legend





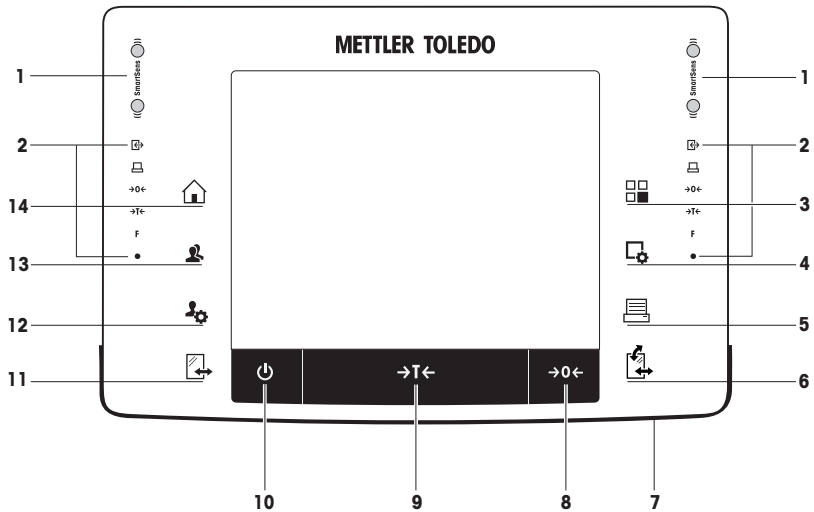

| | | | |
|----|---|----|---|
| 1 | Terminal | 2 | Display "Touch screen" |
| 3 | Operating keys | 4 | SmartSens sensors |
| 5 | Draft shield | 6 | Light barrier |
| 7 | Automated trap door | 8 | Type designation |
| 9 | Handle for transport | 10 | Weighing platform |
| 11 | Level indicator/Level sensor | 12 | Foot screw |
| 13 | StatusLight | 14 | Socket for AC adapter |
| 15 | Slot for second interface (optional) | 16 | RS232C serial interface |
| 17 | Aux 2 (connection e.g. for light barrier) | 18 | Aux 1 (connection e.g. for light barrier) |

Ovweview Terminal



Key assignments and terminal connection.

| | Designation | Explanation |
|---|--------------------|---|
| 1 | SmartSens | Two hands-free sensors. Both of these hands-free sensors can be assigned a specific function (e.g. zeroing, printing or display resolution adjustment). See settings for SmartSens and ErgoSens in the respective applications. |
| 2 | Status bar | The green icons in the status bar indicate the functions assigned to the SmartSens left or SmartSens right . The F symbol represents a function key. SmartSens is deactivated when no green symbol is illuminated. The yellow LED at the bottom of the status bar lights up briefly when a key is selected or a menu function is initiated. |
| 3 | Select application | This key is used to select a required application. |
| 4 | Configuration | For displaying menus for the configuration of a current application. The application can be adjusted to a specific task via numerous settings. |
| 5 | Print | This key is used to transfer data via the interface, e.g. to a printer. Other devices, e.g. a PC can also be connected. The data to be transferred can be freely defined. |

| | | | |
|----|---|----------------------------|--|
| 6 |  | Open/Close | <p>For opening and closing the glass draft shield doors. For convenient right and left-handed operation, one of these keys is provided on both sides of the terminal.</p> <p>Important The key can have different functions if a powder module or autosampler is installed.</p> <ul style="list-style-type: none"> • If powder module and front door are defined as mounted, the key operates the front door. • If powder module is defined as mounted and front door is defined as unmounted, the key operates the side doors. • If autosampler and front door are defined as mounted, the key operates the front door. • If autosampler is defined as mounted and front door is defined as unmounted, the key turns the autosampler clockwise by 1 magazine = 5 positions.  <p>Refer to your Powder Module Operating Instructions or Autosampler Operating Instructions for further information.</p> |
| 7 | | StatusLight | Indicates the current balance status. The status light shows that the balance is ready to use. |
| 8 | →0← | Zeroing | This key is used for setting a new zero point manually (only required if the balance is used for normal weighings). |
| 9 | →T← | Tare | This key is used to tare the balance manually (only necessary for normal weighings). When the balance has been tared, the Net symbol is displayed to indicate that all displayed weights are net. |
| 10 |  | On/Off | <p>For switching the balance on and off (standby mode).</p> <p>Important It is recommended not to disconnect the balance from the power supply unless it is not going to be used for an extended period.</p> |
| 11 |  | Open/Close | <p>For opening and closing the glass draft shield doors. For convenient right and left-handed operation, one of these keys is provided on both sides of the terminal.</p> <p>Important The key can have different functions if an autosampler is installed.</p> <ul style="list-style-type: none"> • If the autosampler is defined as mounted, the key turns the autosampler counterclockwise by 1 magazine = 5 positions. |
| 12 |  | Settings for user profiles | For defining basic settings for each user profile. These settings apply to all user applications. |
| 13 |  | User profile | This key is used to display a specific user profile. Different settings can be saved in a user profile. This allows the balance to be adjusted to a specific user or weighing task. |
| 14 |  | Home | This key is used to return to the user profile Home from any menu level in any application. |

1 Safety Information

- Read and understand the instructions in this manual before you use the balance.
- Keep this manual for future reference.
- Include this manual if you pass on the balance to other parties.

If the balance is not used according to the instructions in this manual or if it is modified, the safety of the user may be impaired and Mettler-Toledo GmbH assumes no liability.

1.1 Definition of signal words and warning symbols

Safety notes are marked with signal words and warning symbols. These show safety issues and warnings. Ignoring the safety notes may lead to personal injury, damage to the instrument, malfunctions and false results.

Signal words

| | |
|----------------|---|
| WARNING | for a hazardous situation with medium risk, possibly resulting in death or severe injury if not avoided. |
| CAUTION | for a hazardous situation with low risk, resulting in minor or moderate injury if not avoided. |
| NOTICE | for a hazardous situation with low risk, resulting in damage to the instrument, other material damage, malfunctions and erroneous results, or loss of data. |
| Note | (no symbol) for useful information about the product. |

Warning symbols



General hazard



Electrical shock

1.2 Product specific safety notes

Your balance represents state-of-the-art technology and complies with all recognized safety rules, however, certain hazards may arise in extraneous circumstances. Do not open the housing of the balance; it does not contain any parts that can be maintained, repaired or replaced by the user. If you experience problems with your balance, contact your authorized METTLER TOLEDO dealer or service representative.

The balance has been tested for the experiments and intended purposes documented in the appropriate manual. However, this does not absolve you from the responsibility of performing your own tests of the products supplied by us regarding their suitability for the methods and purposes you intend to use them for.

Intended use

This balance is designed to be used in analytical laboratories by qualified staff. Your balance is used for weighing. Use the balance exclusively for this purpose.

Any other type of use and operation beyond the limits of technical specifications without written consent from Mettler-Toledo GmbH, is considered as not intended.

Site requirements

The balance has been developed for indoor operation in a well-ventilated area. Avoid the following environmental influences:

- Conditions outside of the ambient conditions specified in the technical data
- Powerful vibrations
- Direct sunlight
- Corrosive gas atmosphere
- Explosive atmosphere of gases, steam, fog, dust and flammable dust
- Powerful electric or magnetic fields

Staff qualification

Incorrect use of the balance or the chemicals used in the analysis can lead to death or injury. The following experience is needed for operating the balance.

- Knowledge and experience in working with toxic and caustic substances.
- Knowledge and experience in working with standard laboratory equipment.
- Knowledge and experience in working in accordance with general lab safety rules.

Responsibilities of the balance owner

The balance owner is the person that uses the balance for commercial use or places the balance at the disposal of his staff. The balance owner is responsible for product safety and the safety of staff, user(s) and third party.

The operator has the following responsibilities:

- Know the rules for safety at the workplace that are in effect and enforce them.
- Ensure that only qualified staff uses the balance.
- Define the responsibilities for installation, operation, cleaning, troubleshooting and maintenance and ensure that the tasks are done.
- Train the staff in regular intervals and inform them about dangers.
- Provide the necessary protective gear for the staff.

Shut down of the balance in emergency situations

- Pull the plug from the electrical outlet.

Protective clothing

Wear protective clothing in the laboratory when working with hazardous or toxic substances.



Use appropriate gloves when handling chemicals or hazardous substances and check their integrity before use.

Safety notes



WARNING

Danger of death or serious injury due to electric shock!

Contact with parts that contain a live current can lead to injury and death. If the balance cannot be shut down in an emergency situations, people can be injured or the balance can be damaged.

- 1 Only use the supplied three-core power cable with equipment grounding conductor to connect your balance.
- 2 Check that the voltage printed on it is the same as your local power supply voltage.
 - ⇒ If this is not the case, under no circumstances connect the AC adapter to the power supply, but contact a METTLER TOLEDO representative.
- 3 Only connect the balance to a three-pin power socket with earthing contact.
- 4 Only standardized extension cable with equipment grounding conductor must be used for operation of the balance.
- 5 Do not disconnection the equipment grounding conductor.
- 6 Check the cables and the plug for damage and replace damaged cables and plugs.
- 7 Make sure that the cables are arranged so that they cannot be damaged or interfere with the operation.
- 8 Keep all electrical cables and connections away from liquids.
- 9 Make sure that the power plug is accessible at all times.



NOTICE

Environment

Only use indoors in dry locations.



NOTICE

Danger of damaging the touch screen with pointed or sharp objects!

Do not use pointed or sharp objects to navigate on the touch screen. This may damage the surface of the touch screen.

- Operate the touch screen with your fingers.



NOTICE

Danger of damage to the balance!

Never open the balance. The balance contains no user-serviceable parts.

- In the event of problems, please contact a METTLER TOLEDO representative.



NOTICE

Danger of damage to the balance due to incorrect parts!

Using incorrect parts with the balance can damage the balance or cause the balance to malfunction.

- Only use parts supplied with the balance, listed accessories and spare parts from Mettler-Toledo GmbH.

Finding more information



Refers to an external document.

FCC Rules

This device complies with Industry Canada licence-exempt RSS standard(s) and part 15 of the FCC Rules. Operation is subject to the following two conditions: (1) this device may not cause interference, and (2) this device must accept any interference, including interference that may cause undesired operation of the device.

Changes or modifications not expressly approved by the party responsible for compliance could void the user's authority to operate the equipment.

This equipment has been tested and found to comply with the limits for a Class A digital device, pursuant to part 15 of the FCC Rules. These limits are designed to provide reasonable protection against harmful interference when the equipment is operated in a commercial environment. This equipment generates, uses, and can radiate radio frequency energy and, if not installed and used in accordance with the instruction manual, may cause harmful interference to radio communications. Operation of this equipment in a residential area is likely to cause harmful interference in which case the user will be required to correct the interference at his own expense.

2 Design and Function

2.1 User interface

2.1.1 Display



NOTICE

Danger of damaging the touch screen with pointed or sharp objects!

Do not use pointed or sharp objects to navigate on the touch screen. This may damage the surface of the touch screen.

- Operate the touch screen with your fingers.

The illuminated, color display of the terminal is a touch screen, i.e. a touch-sensitive screen. It can be used for displaying data, entering settings and selecting functions by tapping the screen.

Important

Depending on country-specific requirements, non-calibrated decimal places are highlighted on approved balances.

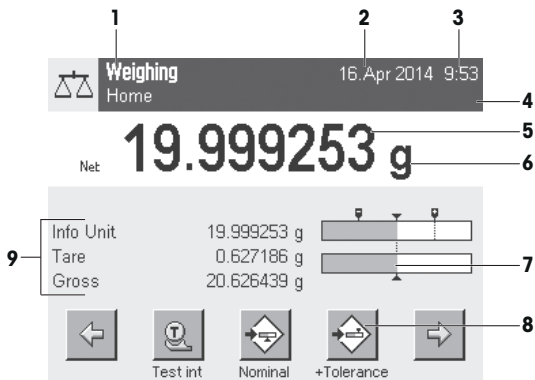

| | Designation | Explanation |
|---|----------------------|--|
| 1 | Application name | Select application. The application menu can be selected by tapping this zone. This menu can also be displayed by pressing [F5]. |
| | Current user profile | Displays the current user profile. |
| 2 | Date | The date can be changed by tapping this zone. |
| 3 | Time | The time can be changed by tapping this zone. |
| 4 | Status icons | These status icons indicate special balance statuses (e.g. service due, adjustment required, battery replacement, out of level). If you tap the icon, the function is explained. |
| 5 | Weight value | Tapping the weight displays a window showing the result in a large format. This is useful for reading a weight from a certain distance. |
| 6 | Weighing unit | The required weighing unit can be changed by tapping the weighing unit, e.g. from mg to g . |
| 7 | SmartTrac | SmartTrac is a graphic weighing-in aid, which shows at a glance an already used and still available weighing range. |
| 8 | Function keys | This area is reserved for Function Keys enabling direct access to frequently required functions and application settings. If more than 5 function keys are activated, these can be selected with the arrow keys. |
| 9 | Information fields | This area is used for displaying additional information (information fields) relating to an active application. Tapping the information field enables Information fields and Function Keys to be displayed directly via menu selection. The leveling assistant can also be started. |

Large display

By pressing the function key **[Display]**, the weighing result can be displayed larger and still allow the use of the terminal function keys.



Screen saver

If the balance is not used for 15 minutes, the display is automatically dimmed and the pixels are inverted about every 15 seconds. When the balance is used again (e.g. load weight, press key), the display returns to a normal state.

2.1.2 Input dialog boxes

The keyboard dialog box is used to enter characters such as letters, numbers and special characters.

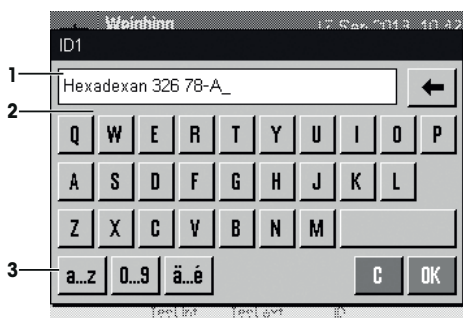

| | Designation | Explanation |
|---|-------------|---|
| 1 | Data field | Displays (entered) alphanumeric and numeric characters. |
| 2 | Keyboard | Data input area |
| 3 | Selection | Select various keyboard layouts. |

1 Enter the designation.

2 Confirm with [OK].

| | Function |
|--|---|
| | Delete last character Tap once to place the cursor at the end of the data field. |

2.1.3 Firmware

The firmware controls all balance functions. It enables the balance to be adjusted to a specific working environment.

The firmware is divided as follows:

- System settings
- User profiles
- User-specific settings

- Applications
- Application-specific settings

Note

A displayed menu can be left at any time by repressing the same menu key.

2.1.3.1 System settings

System settings (e.g. settings for peripheral devices) are independent of the user profiles and applications and apply to the entire weighing system. System settings can be displayed by pressing [**☰**] or [**☰**] and then the [**System**] button.

Navigation: [**☰**] > **System**

or

Navigation: [**☰**] > **System**

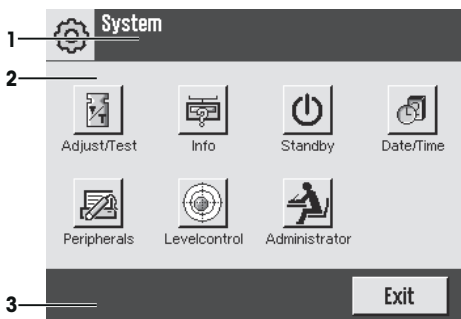

| | Designation | Explanation |
|---|---------------|---|
| 1 | Title bar | The title bar displays elements for user orientation and information. |
| 2 | Contents area | The contents area is the main work area for menus and applications. The contents depend on the specific application or initiated action. |
| 3 | Action bar | The action bar contains action buttons for performing specific actions required in the active dialog box and are available (e.g. [Exit], [STD], [C], [OK]). |

- 1 Settings can be changed by tapping the respective button.
- 2 To leave the settings, tap [**Exit**].

2.1.3.2 User profiles

User profiles are used to adjust the balance to suit specific applications and personal work techniques or specific weighing tasks. A user profile is a collection of user defined settings that can be selected at the press of a button. The last active user profile is automatically loaded when the balance is switched on.

Navigation: [F2]

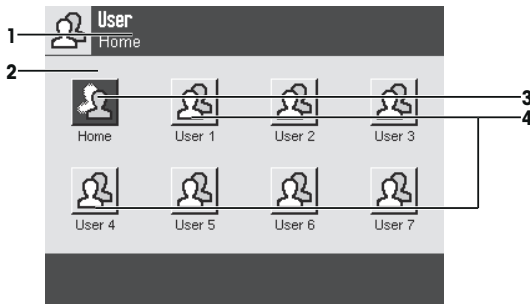

| | Designation | Explanation |
|---|---------------|---|
| 1 | Title bar | The title bar displays elements for user orientation and information. |
| 2 | Contents area | The contents area is the main work area for menus and applications. The contents depend on the specific application or initiated action. |
| 3 | Home | The Home profile is a starting point that can be returned to at any time by pressing the [Home] key. It contains factory settings for all users. These settings can be changed as required. It is recommended not to change the Home profile factory settings, but make adjustments in further user profiles. |
| 4 | User profiles | Settings in further user profiles can be changed as required. All settings made in an active user profile are saved under this profile. This includes both application and user-specific settings. The system settings are not changed. |

– A user profile can be changed by tapping the respective button.

2.1.3.3 User-specific settings

These settings can be used to adjust the balance to suit the tasks and work techniques of individual users. The settings can be defined separately for each user profile and for the **Home** profile. When a user profile is selected, the corresponding user-specific settings are automatically loaded.

Navigation: [F4]

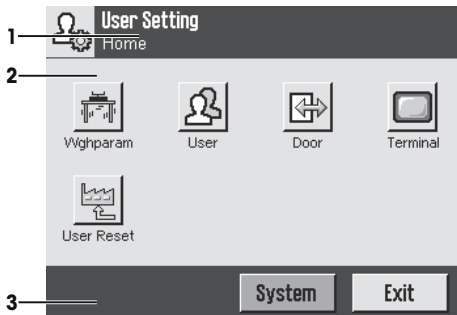

Applications

Applications are firmware modules for performing specific weighing tasks. The balance is delivered with various applications pre-installed. After switching on the balance, the last active user profile and last used application are loaded. The applications are available under the [F4] key. Instructions for working with standard applications are provided in the respective sections.

Navigation: [☰]

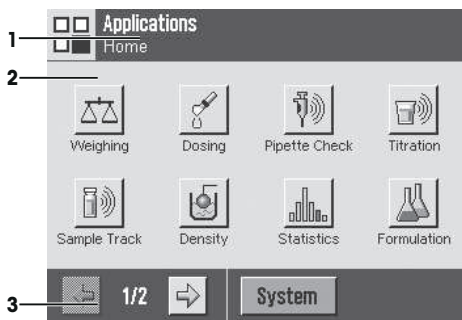

Application-specific settings

These settings can be used to adjust the applications to suit individual user requirements. The available setting options depend on the selected application. Pressing [L4] opens the multipage menu with settings for a currently active application. Information on the individual setting options is provided in the section relating to the respective application. Settings can be defined separately for each user profile and for the **Home** profile. When a user profile is selected, the corresponding application-specific settings are automatically loaded.

Navigation: [L4]

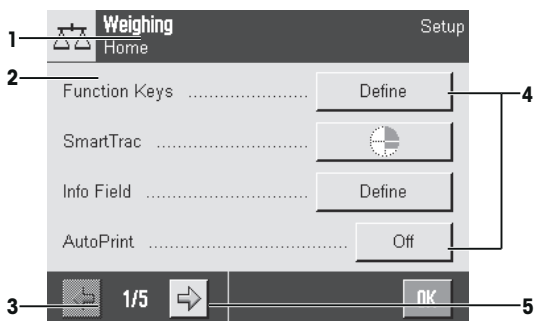

| | Designation | Explanation |
|---|---------------|---|
| 1 | Title bar | The title bar displays elements for user orientation and information. |
| 2 | Contents area | The contents area is the main work area for menus and applications. The contents depend on the specific application or initiated action. |
| 3 | Action bar | The action bar contains action buttons for performing specific actions required in the active dialog box and are available (e.g. [Exit], [STD], [C], [OK]). |
| 4 | Button | Edit/Select settings (e.g. [Define], [On], [Off]). The contents depend on the application. |
| 5 | Arrow | The arrow buttons are used to page forward or back. |

- 1 Settings can be changed by tapping the respective button.
- 2 Confirm with [OK].
- 3 To leave the settings, select [Exit].
- 4 To change the system settings, tap [System].

2.1.4 Security system



NOTICE

Remember IDs and passwords!

Protected menu areas cannot be accessed without ID or password.

- Note IDs and passwords and keep them in a safe place.

The balance has a comprehensive security system with which individual access rights can be defined at administrator and user level. Settings that may be changed can be defined for each individual user profile. Access to protected menu areas requires the entry of identification (ID) and a password. On delivery of the balance, only the **[Administrator]** settings in the system settings are protected.

When an ID and password protected menu area is selected, an alphanumeric keyboard is initially displayed for entry of the ID.

- 1 Enter your ID.
 - Case sensitive, tap the **[a...z]** and **[A...Z]** button to switch between upper and lower case.
 - To enter numbers, tap the **[0...9]** button.
 - Incorrect entries can be deleted character by character with the arrow key **←**.

Note

Entry can be interrupted at any time by tapping **[C]**.

- 2 After entering the full ID, tap **[OK]**.
 - ⇒ A further dialog box is displayed for entering the password.
- 3 Enter the password (for security reasons, this is displayed with asterisks instead of plain text) and confirm with **[OK]**.
 - ⇒ If the ID and password are correct, the selected menu area is displayed or the required action initiated. If these are incorrect, an error message is displayed with a request to enter them again.

3 Installation and Putting into Operation

Finding more information

► www.mt.com/pipcal

3.1 Unpacking

Open the balance packaging. Check the balance for transport damage. Immediately inform a METTLER TOLEDO representative in the event of complaints or missing accessories.

Important

Retain all parts of the packaging. This packaging offers the best possible protection for transporting the balance.

- 1 Open the outer packaging box.
- 2 Remove it from the packaging the Unpacking and packing instructions.
- 3 Lift the cardboard box (1) out of the packaging.
- 4 Remove the operating instructions (2).
- 5 Remove the AC adapter and the power supply cable.

The box also contains all accessories required for the balance.



- Use the lifting strap to lift the balance out of the packaging box.

- 1 Remove the lifting strap (3).
- 2 Remove the top packaging (4).

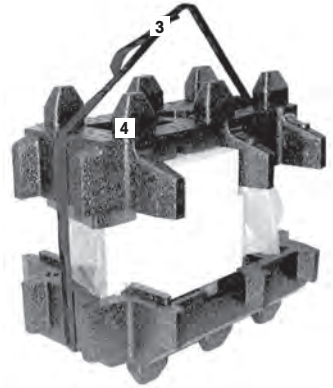

- 3 Pull the inner padding (5) straight upward.



- 4 Carefully remove the terminal (6) from the bottom packaging (7).
- 5 Remove the protective cover.

Note

Since the terminal is connected to the balance with a cable, only withdraw the balance slightly from the packaging in order to remove the protective cover.



- 6 Place the terminal (6) at the front of the balance.
- 7 Hold the balance by the guide or handle (8). Hold the terminal firmly with the other hand. Pull out both components together from the bottom packaging (7).
- 8 Place the balance with the terminal at the site of use.
- 9 Remove the cover from the balance.



3.2 Scope of delivery



NOTICE

Danger of damage to the balance due to incorrect parts!

Using incorrect parts with the balance can damage the balance or cause the balance to malfunction.

- Only use parts supplied with the balance, listed accessories and spare parts from Mettler-Toledo GmbH.

The standard scope of delivery contains the following items:

- Balance with terminal
 - RS232C interface
 - Slot for second interface (optional)
 - Feedthroughs for below-the-balance weighing and for antitheft device
- Protective cover for the terminal
- AC adapter with country-specific power cable
- Terminal support
- Draft shield
- Glass cover
- Centering ring
- Water container
- Automated trap door
- Hanger
- Pipetting container
- Drip tray
- Light barrier with connecting cable
- Knurled screw
- Cable holder
- Suction pump incl. AC adapter
- Cleaning brush
- Calibration kit (plastic case with 2 weighing pans for external adjustment/test weights, cover with adapter for large weight, tweezers)
- Production certificate
- CE declaration of conformity
- Operating instructions or User Manual; printed or on CD-ROM, depending on country of use

3.3 Selecting the location

An optimal location will ensure accurate and reliable operation of the balance. The surface must be able to safely take the weight of the balance when fully loaded. The following local conditions must be observed:

Important

If the balance is not horizontal at the outset, it must be leveled during commissioning.

- The balance must only be used indoors and up to a maximum altitude of 4,000 m above sea level.
- Before switching on the balance, wait until all parts are at room temperature (+5 to 40 °C). The humidity must be between 10% and 80% non-condensing.
- The power plug must be accessible at all times.
- Firm, horizontal and vibration-free location.
- Avoid direct sunlight.
- No excessive temperature fluctuations.
- No strong drafts.

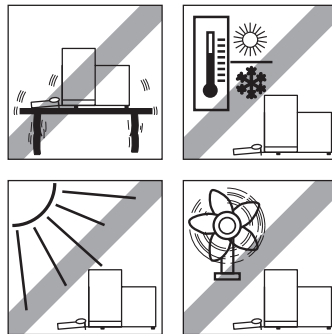

Further information can be found in Weighing the Right Way.

3.4 Assembling the balance

- 1 Insert the drip tray in the opening provided in the bottom plate.



- 2 Turn the holding plate 90° to the left or right into the open position.

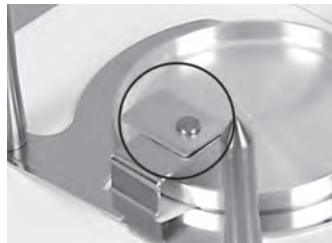

- 3 Insert the hanger.



- 4 Turn the holding plate 90° to the left or right into the closed position.
⇒ The holding plate prevents the hanger from becoming unhooked.

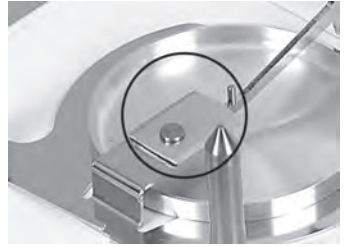

- 5 Place the pipetting container on the hanger.



- 6 Place the draft shield on the column of the balance and press it firmly down onto the positioning pin.

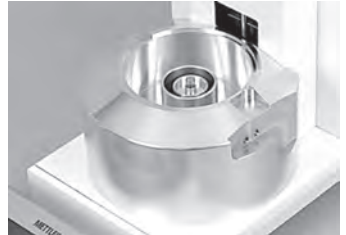

- 7 Insert the water container into the draft shield.



- 8 Place the centering ring into position.



- 9 Place the glass cover into position.



- 10 Hang the automated trap door on the rods.



Install the light barrier

- 1 Lay the cover plate of the light barrier cable against the side wall of the balance.
- 2 Push it toward the front into the openings provided in the balance housing.

Note

The light barrier can optionally be installed on the left or right side of the balance.

- 3 Insert the connecting cable of the light barrier into the back of the cover plate and plug into the "Aux 1" or "Aux 2" connector on the back of the balance.
- 4 The selected connector must subsequently be specially configured for the light barrier. **See** [Setting for the light barrier ▶ Page 24].
- 5 Place the light barrier on the draft shield and fasten it with the knurled screw.

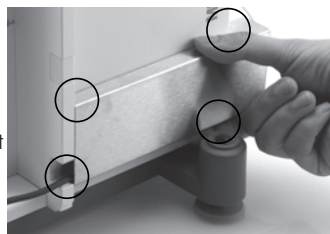

- 6 Insert the cable holder into the balance housing.



3.5 Installation of the terminal

- 1 Insert the terminal support.
- 2 Place the cable in the guide of the terminal support.
- 3 Insert the terminal support into the opening in the front draft shield glass.
⇒ The terminal support must engage with a click.

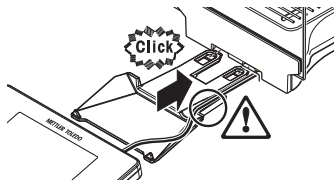

- 1 Mount the terminal.
- 2 Place the terminal in the center of the support.
- 3 Push the terminal against the balance until it folds down easily at the front of the terminal support.
- 4 Insert the cable into the balance.

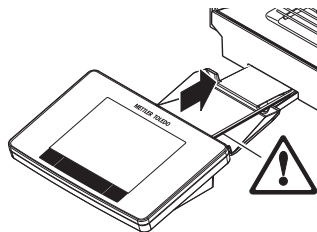

NOTICE

Danger of damage to the terminal!

- The balance and terminal are not connected by the terminal support!
- Always hold the balance and terminal firmly during transport.

Note

You can also place the terminal free of the terminal support anywhere around the balance where the length of the cable allows.

3.6 Connecting the balance



⚠ WARNING

Danger of death or serious injury due to electric shock!

Contact with parts that contain a live current can lead to injury and death. If the balance cannot be shut down in an emergency situations, people can be injured or the balance can be damaged.

- 1 Only use the supplied three-core power cable with equipment grounding conductor to connect your balance.
- 2 Check that the voltage printed on it is the same as your local power supply voltage.
 - ⇒ If this is not the case, under no circumstances connect the AC adapter to the power supply, but contact a METTLER TOLEDO representative.
- 3 Only connect the balance to a three-pin power socket with earthing contact.
- 4 Only standardized extension cable with equipment grounding conductor must be used for operation of the balance.
- 5 Do not disconnection the equipment grounding conductor.
- 6 Check the cables and the plug for damage and replace damaged cables and plugs.
- 7 Make sure that the cables are arranged so that they cannot be damaged or interfere with the operation.
- 8 Keep all electrical cables and connections away from liquids.
- 9 Make sure that the power plug is accessible at all times.



NOTICE

Danger of damage to the AC adapter due to overheating!

If the AC adapter is covered or in a container, it is not sufficiently cooled and overheats.

- 1 Do not cover the AC adapter.
- 2 Do not put the AC adapter in a container.

The balance is supplied with an AC/DC adapter and a country-specific power cable. The AC/DC adapter is suitable for use with the following voltage range:

100 – 240 V AC, 50/60 Hz.

- Balance and terminal are at the final location.
- 1 Connect the AC adapter (1) to the connection socket (2) at the rear of the balance.
 - 2 Connect the AC adapter (1) to a grounded electrical outlet.
- ⇒ The balance performs a self-test after connection to the power supply and is then ready to use.

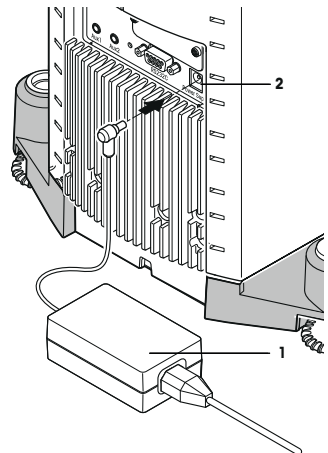

3.7 Setting up the balance

Switching on the balance

- Balance is connected to the power supply.
- Terminal and balance are interconnected.
- To switch on, press [⏻].
 - ⇒ Display appears.
- ⇒ Balance is ready to use.



Leveling the balance

The balance has a built-in level sensor which permanently monitors correct horizontal alignment.

If the balance is not exactly level, a warning text is generated after switching on the balance with the request to level the balance.

If the level sensor detects incorrect leveling, the status light at the terminal shows red. A warning text is displayed and an audible warning generated. A status icon also appears in the top right corner of the display.



- 1 To start the leveling assistant, tap [LevelGuide] in the warning message.
 - ⇒ Window with level indicator is displayed in real-time.
- 2 Observe the level indicator on the screen.
 - ⇒ The air bubble in the level indicator shows red with incorrect alignment.
 - ⇒ The leveling assistant indicates with red arrows the direction in which the two foot screws at the rear of the balance must be turned.
- 3 Turn the foot screw until the air bubble is located in the inner circle of the level indicator.
 - ⇒ The air bubble in the level indicator shows green with correct alignment.
 - ⇒ The status light at the terminal shows green.
- 4 Tap [OK].
 - ⇒ A message recommending adjustment of the balance is displayed.
- 5 Tap [Adjust.int] to adjust the balance.

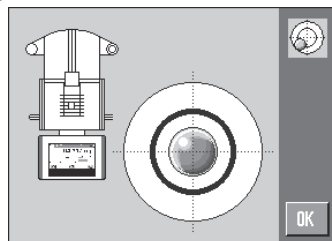
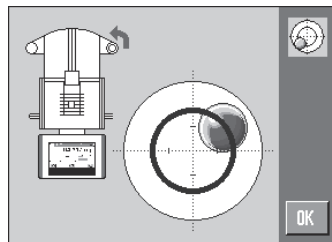

3.7.1 Performing a simple weighing

After commissioning of the new balance, the first weighing can be performed.

To perform a simple weighing, only the keys in the lower part of the terminal are required. The balance has separate keys for zeroing [→0←] and taring [→T←].

Zeroing

- Press [→0←].
- ⇒ Zeroing

After zeroing, all weights also the tare weight apply to this new zero point and the following apply: tare weight = 0, net weight = gross weight = 0.

Taring

Important

A negative weight is not permitted. An error message is generated. When the stability detector icon extinguishes (small ring left of the weight display), the indication is stable. The weight is displayed.

- If a weighing container is used, the balance must first be set to zero.
- 1 Place the container on the balance.
 - 2 Press [→T←].
 - ⇒ The balance is tared.
- ⇒ The weight of the container is set as the new tare weight and the previous tare (if available) is overwritten.
- ⇒ The **Net** display signals that all indicated weights are net weights.



3.8 Suitable applications for pipette calibration

The XPE26PC offers all the applications of the XPE balances. However, of those applications, only the following applications are suitable for calibrating pipettes.

Note

For greater clarity, you can switch off the applications you don't need. **See Navigation:** [F6] > [System] > [Administrator] > **Rights Home** > **Application Selection**

- Weighing
- Statistics
- Percent weighing (in exceptional cases)

You will find information about these applications in the respective chapter. Read the respective chapter and familiarize yourself with the settings and how to work with the applications.

Selecting the application

Navigation: [F6] > [Weighing]

- 1 Press [F6].
 - 2 Tap the [Weighing] icon in the selection window.
 - ⇒ The selected application is active.
- ⇒ The balance is ready for weighing.

3.8.1 Setting for the light barrier

The light barrier of your XPE26PC automatically opens and closes the automated trap door of the draft shield when you pass the pipette through the light barrier. This saves you having to close the trap door manually with the [↵] key. From the point of view of the XPE26PC, the light barrier is an "ErgoSens" and must therefore be configured as follows.

Note

If you are working with the METTLER TOLEDO Calibry PC software, a different setting must be used. **See** Settings for the automated trap door function.

Navigation: [F6] > [Weighing] > [↵] > **Smart & ErgoSens**

- 1 Press [↵].
 - ⇒ A window with application-dependent settings is appears.
- 2 Tap **Smart & ErgoSens** > [Define].
 - ⇒ A selection window is appears.
- 3 Switch both SmartSens off.
 - or
 - Assign to them any function except door opening.
- 4 Beside the ErgoSens to which the light barrier is connected (**Aux 1** or **Aux 2**), tap the associated button.
 - ⇒ A selection window is appears.

5 Activate [**Door**] and confirm with [**OK**].

⇒ The light barrier is now active.

3.9 Calibrating Pipettes

▪ It is assumed that the balance is switched on and that you have already made the settings according to chapter [Suitable applications for pipette calibration ▶ Page 24] and [Setting for the light barrier ▶ Page 24].

1 Switch the balance on [**⏻**].

2 Wait at least **2 hours** before you start work.

⇒ This allows the balance to adapt to the ambient conditions.

3.9.1 Fill water container

The draft shield with glass cover and the water container serve as an evaporation trap. Inside the evaporation trap, there is a virtually saturated atmosphere that prevents evaporation of water from the pipetting container and consequent distortion of the measurement results.

1 Remove the automated trap door and the glass cover.

2 Check the level of liquid in the water container.

The container should be at least half full.

3 If the water level is too low, add distilled water.

NOTICE

Do not overfill the container!

4 Replace the glass cover and mount the automated trap door.

Important

Wait at least 2 hours before the next calibration, so that the temperature and humidity in the measuring chamber are correct.



3.9.2 Perform the calibration

- 1 Press the [**→0←**] key to set the balance to zero.
For pipettes with variable volume:
- 2 On the pipette, set the volume for the first measurement operation (e.g. 10% of the nominal volume).
Comply with any additional instructions for preparing the pipette (e.g. according to ISO 8655).
- 3 With the pipette, suck the set volume out of the water bath.
- 4 Pass the tip of the pipette through the light barrier to open the automated trap door.
- 5 Empty the pipette into the pipetting container.
Comply with all rules for correct pipetting (e.g. ISO 8655).
- 6 Pass the pipette back through the light barrier to close the automated trap door.
 - ⇒ When the measurement result becomes stable (the circle of the stability detector left of the results disappears) you can read the result.
 - ⇒ If a PC is connected, you can transmit the result to the host computer by pressing the [] key or the [**Transfer Key**] function key.
See Output data formatting (transfer key).
 - ⇒ If you are working with the METTLER TOLEDO Calibry software, the result is automatically transmitted to the host computer.
See XPE26PC and Calibry.
- 7 Before you perform the next pipetting, press the [**→0←**] key again to reset the display to zero.



4 Maintenance

4.1 Cleaning

Periodically clean the weighing chamber, the housing, and the terminal of your balance using the brush supplied with it. The maintenance interval depends on your standard operating procedure (SOP).

Please observe the following notes



WARNING

Danger of death or serious injury due to electric shock!

Contact with parts that contain a live current can lead to injury and death. If the balance cannot be shut down in an emergency situations, people can be injured or the balance can be damaged.

- 1 Disconnect the balance from the power supply prior to cleaning and maintenance.
- 2 Only use METTLER TOLEDO power cable, if these need to be replaced.
- 3 Make sure that no liquid enters into the balance, terminal or AC adapter.
- 4 Do not open the balance, terminal or AC adapter.
These contain no user-serviceable parts.



NOTICE

Danger of damage to the balance due to inappropriate cleaning methods!

The balance is made from high quality, resistant materials and can be damaged by certain cleaning agents, solvents or abrasives. If liquids enter the housing they can damage the balance.

- 1 Use only water and a mild detergent to clean the balance or terminal.
- 2 Wipe off any spills immediately.
- 3 Make sure that no liquid enters the interior of the balance.

Cleaning

Your balance is made from high quality, resistant materials and can therefore be cleaned with a commercially available, mild cleaning agent.

Important

Contact a METTLER TOLEDO representative to find about the service options available – regular maintenance by an authorized service engineer will ensure consistent weighing accuracy over the long term and extend the service life of the balance.

4.1.1 Cleaning after overflow

If you overflow the pipetting container, or if water runs out next to the filling hole, a water film forms between the glass tube and the centering ring. This water film has a suction effect that can cause the liquid not to go into the pipetting container but instead to be sucked outside. Because of this, the measurement result may never become stable. Therefore, if such a water film forms, it must be removed immediately.

- 1 Close and remove the automated trap door.
- 2 Remove the glass cover.
- 3 Remove the centering ring and dry it.
- 4 Use an absorbent cloth to remove the water from the top part of the pipetting container.
- 5 If the water film was formed because the pipetting container is full, the container must be emptied.

See [Emptying the pipetting container ▶ Page 27].



4.1.2 Emptying the pipetting container

If the pipetting container is full, the container must be emptied with the suction pump that was delivered with the balance.



NOTICE

Danger of damage the pump!

- Do not run the pump for too long after it is empty; it may damage the pump!
- Switch off the suction pump.

- 1 Open or remove the automated trap door.
 - 2 Connect the suction pump to the power supply via the AC adapter.
 - 3 Connect the suction tube (with the probe) to the input side ("IN") of the pump.
 - 4 Connect the second pipe to the output side ("OUT") of the pump and place the free end of the pipe in a suitable drainage container.
 - 5 Carefully introduce the suction probe into the pipetting container.
 - 6 Switch the pump on by pressing the button and drain the pipetting container.
- ⇒ This should only take a few seconds.



4.2 Disposal

In conformance with the European Directive 2012/19/EU on Waste Electrical and Electronic Equipment (WEEE) this device may not be disposed of in domestic waste. This also applies to countries outside the EU, per their specific requirements.

Please dispose of this product in accordance with local regulations at the collecting point specified for electrical and electronic equipment. If you have any questions, please contact the responsible authority or the distributor from which you purchased this device. Should this device be passed on to other parties (for private or professional use), the content of this regulation must also be related.

Thank you for your contribution to environmental protection.



5 Technical Data

5.1 General data



WARNING

Danger of death or serious injury due to electric shock!

Contact with parts that contain a live current can lead to injury and death.

- 1 Only use an approved AC adapter with a current-limited SELV output.
- 2 Ensure correct polarity 

Power supply

| | |
|-----------------------|--|
| AC adapter: | Primary: 100 – 240 V AC, -15%/+10%, 50/60 Hz Secondary: 12 V DC \pm 3%, 2.5 A (with electronic overload protection) |
| Cable for AC adapter: | 3-core, with country-specific plug |
| Balance power supply: | 12 V DC \pm 3%, 2.25 A, maximum ripple: 80 mVpp |

Protection and standards

| | |
|-------------------------------|---------------------------------------|
| Overvoltage category: | II |
| Degree of pollution: | 2 |
| Protection: | Protected against dust and water |
| Standards for safety and EMC: | See Declaration of Conformity |
| Range of application: | For use only in closed interior rooms |

Environmental conditions

| | |
|------------------------------|--|
| Height above mean sea level: | Up to 4000 m |
| Ambient temperature: | 5–40 °C |
| Relative air humidity: | Max. 80% up to 31 °C, linearly decreasing to 50% at 40 °C, noncondensing |

Warm-up time:

At least **180** minutes after connecting the balance to the power supply; when switched on from standby-mode, the balance is ready for operation immediately

Materials

Housing:

Die-cast aluminum, plastic, chrome steel and glass

Terminal:

Die-cast zinc, chromed and plastics

GWP®

Good Weighing Practice™

GWP® is the global weighing standard, ensuring consistent accuracy of weighing processes, applicable to all equipment from any manufacturer. It helps to:

- Choose the appropriate balance or scale
- Calibrate and operate your weighing equipment with security
- Comply with quality and compliance standards in laboratory and manufacturing

 www.mt.com/GWP

www.mt.com/pipcal

For more information

Mettler-Toledo GmbH

Im Langacher 44
8606 Greifensee, Switzerland
www.mt.com/contact

Subject to technical changes.
© Mettler-Toledo GmbH 11/2016
30134982D en



30134982