



Australian Government

National Measurement
Institute

Bradfield Road, West Lindfield NSW 2070

Certificate of Approval

NMI 13/1/22

Issued by the Chief Metrologist under Regulation 60
of the
National Measurement Regulations 1999

This is to certify that an approval for use for trade has been granted in respect of the instruments herein described.

Mettler Toledo Cargoscan Model CSN210.2 *Massflow*™ Dimensional Measuring Instrument

submitted by Mettler-Toledo Limited
 220 Turner Street
 Port Melbourne VIC 3207

NOTE: This Certificate relates to the suitability of the pattern of the instrument for use for trade only in respect of its metrological characteristics. This Certificate does not constitute or imply any guarantee of compliance by the manufacturer or any other person with any requirements regarding safety.

This approval has been granted with reference to document NMI R 129, *Multi-dimensional Measuring Instruments*, dated July 2004.

This approval becomes subject to review on 1/05/17, and then every 5 years thereafter.

DOCUMENT HISTORY

Rev	Reason/Details	Date
0	Pattern and variant 1 approved – certificate issued	13/04/12

CONDITIONS OF APPROVAL

General

Instruments purporting to comply with this approval shall be marked with approval number 'NMI 13/1/22' and only by persons authorised by the submittor.

It is the submittor's responsibility to ensure that all instruments marked with this approval number are constructed as described in the documentation lodged with the National Measurement Institute (NMI) and with the relevant Certificate of Approval and Technical Schedule. Failure to comply with this Condition may attract penalties under Section 19B of the National Measurement Act and may result in cancellation or withdrawal of the approval, in accordance with document NMI P 106.

Auxiliary devices used with this instrument shall comply with the requirements of General Supplementary Certificates No S1/0/A or No S1/0B.

Special

Instruments are only approved for use for determination of the dimensions and volume of the smallest rectangular box that could contain an object, for the purposes of determining freight or postal charges.

The dimensions determined may also be used for the calculation (by peripheral equipment) of a volume and/or 'dimensional weight' (*) value of the object, also for the purposes of determining freight or postal charges.

(*) A 'dimensional weight' value is a calculated value deemed to be a weight value obtained by applying a conversion factor to the object's volume.

Signed by a person authorised by the Chief Metrologist to exercise his powers under Regulation 60 of the *National Measurement Regulations 1999*.



TECHNICAL SCHEDULE No 13/1/22

1. Description of Pattern

approved on 13/04/12

A Mettler Toledo Cargoscan model CSN210.2 *Massflow*™ dimensional measuring instrument (Figure 1) which is approved for use for the determination of the linear dimensions of certain objects while they are in motion. Instruments may be fitted with output sockets (output interfacing capability) for the connection of auxiliary and/or peripheral devices.

1.1 Details

The pattern is approved for use for the determination of the linear dimensions of objects having maximum dimensions (i.e. length × width × height) of 250 × 120 × 92 cm and minimum dimensions 10 × 10 × 10 cm, with a scale interval of measurement (d) of 5 mm and a belt speed (V_{max}) of up to 78 m/min.

The pattern converts the detected characteristics into the linear dimensions of the smallest rectangular box (parallelepiped – #) that would fully contain the object.

The pattern is approved for use in measuring the linear dimensions of opaque objects only; the dimensions determined may also be used for the calculation of volume and/or 'dimensional weight' value (*) of the item (refer to the Special Conditions of Approval).

Note: This instrument is NOT suitable for:

- Transparent objects and objects packed in thick, transparent wrapping material, e.g. 'bubble wrap'; or
 - Objects with a mirror-like surface, e.g. chrome or other high gloss finish, however, the instrument can measure objects covered in shiny sealing tape or glossy plastic wrapping, e.g. 'cling wrap'.
- (#) A rectangular box (parallelepiped) is a polyhedron having six faces that are parallel in pairs; each face is a parallelogram and adjacent edges are perpendicular.
- (*) A '**dimensional weight**' value is a calculated value deemed to be a weight value obtained by applying a conversion factor to the object's volume as calculated from the measured dimensions.

1.2 Dimensioning Unit

The pattern includes a Cargoscan model CSN210 dimensioning unit mounted on a supporting frame above a belt-conveyor type load receptor (Figure 1 shows a typical conveyor arrangement). The dimensioning unit (Figure 1) uses a laser rangefinder and optical scanner system with a rotating mirror used to deflect the light beam across the width of the measurement area. The optical scanner measures the reflected light, and with data from the pulse generator (see cl. **1.3 Pulse Generator**), this is analysed by the CPUs in the dimensioning unit to determine the linear dimensions of the object.

Measurement results are output to the CS2200LX indicator or an optional Mettler Toledo model CNC440 workstation. The system operates using Cargoscan version 1.0.1.x software.

1.3 Pulse Generator

The pulse generator pulses are used during the data analysis to measure the speed of the conveyor to determine length of the object. The pulse generator is attached to the underside of the conveyor and is fitted with a wheel that touches the conveyor. When the conveyor belt moves, the wheel rotates and pulses are generated that are counted by the CPU.

1.4 Indicator Unit

A Mettler Toledo model CS2200LX indicator (Figure 3) provides a 4 line alphanumeric LCD display for indication of measurement results. The indicator is also used to operate and configure the instrument and displays any error messages that occur during a measurement operation.

Indicator (traffic signal) lamps (if fitted) signal when the system is operating, a measurement is in progress or an error has been detected.

1.5 Workstation

An optional Mettler Toledo workstation (Figure 4) operating OctoCSM software may also be used to initiate measurement operations and display results, as well as collecting additional information about the object being measured via barcode scanners or keyboard data entry.

1.6 Indications

The pattern is fitted with a model CS2200LX indicator however measurement data from the CSN210.2 is also made available to other systems for indication and/or printing. The instrument may be fitted with Alibi Memory Storage that stores all measurements in a non-volatile memory inside the instrument for later recall. Note that printing is NOT mandatory, however any ticket printed must comply with the extract below.

Displayed information must be made available for verification and must comply with the requirements set out in document NMI R129, *Multidimensional Measuring Instruments*, in particular as per the extract below.

7.9.1 Any printed ticket or displayed indication shall include sufficient information to identify the transaction, for example:

- (a) dimensions: length (*L*), width (*W*) and height (*H*);
- (b) volume (vol);
- (c) weight (*Wt*) if the instrument includes a weighing instrument;
- (d) dimensional weight (Dim *Wt* ... kg or *DW* ... kg);
- (e) dimensional tare (*DT* ... kg);
- (f) conversion factor (*F*);
- (g) quantity for charging, for example dimensions, vol or *DW* ... kg;
- (h) price rate and price; and
- (i) date, transaction number or other identification of the object.

Note 1: Icons may be used to identify indications.

Note 2: When the customer is not present during the measurement process the above information need not be displayed or printed out at the time but shall be available on request.

Note 3: The price interval and the price rate shall comply with the national regulations applicable for trade.

7.9.2 A printed ticket shall also contain the following printed or pre-printed information:

- (a) that the dimensions and/or volume shown are those of the smallest rectangular box that fully encloses the object; and
- (b) that the dimensional weight is a calculated value deemed to be a weight value obtained by applying a conversion factor to the object's volume or dimensions.

1.7 Descriptive Markings and Notices

- (a) Instruments carry the following markings (in the vicinity of the indicating device):

Manufacturer's mark, or name written in full	Mettler Toledo Cargoscan A/S
Importer's mark, or name written in full	Mettler-Toledo Limited
Model designation
Serial number of the instrument
Year of manufacture
Pattern approval mark	NMI 13/1/22
Maximum dimensions for each axis	<i>Max</i> cm
Minimum dimensions for each axis	<i>Min</i> cm
Scale interval	<i>d</i> = cm
Maximum belt speed	<i>Max</i> m/min
Minimum belt speed	<i>Max</i> m/min

- (b) Instruments carry one or more notices stating REFLECTIVE OR TRANSPARENT ITEMS CANNOT BE MEASURED, and ITEMS MUST BE PLACED WITH LARGEST AND MOST STABLE SURFACE DOWN, or similar wording.

1.8 Verification Provision

Provision is made for the application of a verification mark.

1.9 Sealing Provision

Provision is made for sealing the calibration adjustments in software using an audit trail which records adjustments.

Provision is also made for sealing the CSN210.2 dimensioning unit by means of sealing labels applied over edges of the enclosure (Figures 1b and 2a).

In addition, the pulse generator is sealed as shown in Figure 2b, in accordance with the manufacturer's instructions.

2. Description of Variant 1

approved on 13/04/12

A Mettler Toledo Cargoscan model CSN210.3 *Massflow*™ dimensional measuring instrument having the features and specifications of the pattern except for having maximum width dimension 180 cm.

TEST PROCEDURE No 13/1/22

Instruments shall be tested in accordance with any relevant tests specified in the National Instrument Test Procedures.

Note: Refer to clause **1.6 Indications** – Displayed information must be made available for verification and must comply with the requirements set out in document NMI R 129, *Multi-dimensional Measuring Instruments*, dated July 2004.

Maximum Permissible Errors

The maximum permissible errors are specified in Schedule 1 of the *National Trade Measurement Regulations 2009*.

The maximum permissible error at verification is:

± 1.0 cm for lengths from the minimum length to any value up to and including the maximum length capacity of the instrument.

Instruments shall be tested as follows:

- (a) Test objects shall be used of known lengths such that each axis (i.e. length \times width \times height) is tested for at least five dimensions between and including the minimum and maximum lengths specified on the instrument nameplate. Each test object shall be rigid and with well-defined edges to simulate the edges of a rectangular box. The lengths shall be known to an uncertainty equal to or better than $\pm 1/5$ of the maximum permissible error, which is equal to the scale interval (*d*).
- (b) Carry out at least three test runs for each length, varying position and orientation across the receptor. Each measurement shall be within the maximum permissible error.
- (c) Check that instruments are marked and carry one or more notices in accordance with clause **1.7 Descriptive Markings and Notices**.

FIGURE 13/1/22 – 1



(a) Mettler Toledo Cargoscan Model CSN210.2 *Massflow*™ Installation

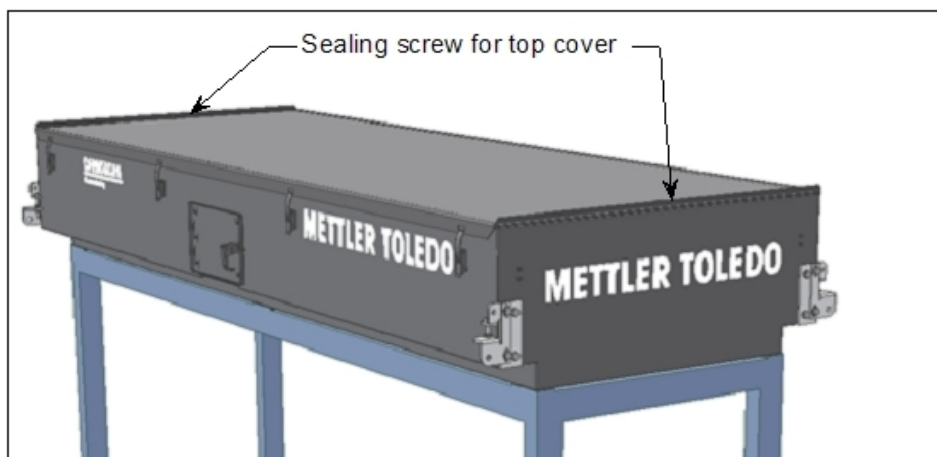

(b) Cargoscan Model CSN210 Dimensioning Unit Including Typical Sealing

Mettler Toledo Cargoscan Model CSN210.2 *Massflow*™
Dimensional Measuring Instrument

FIGURE 13/1/22 – 2

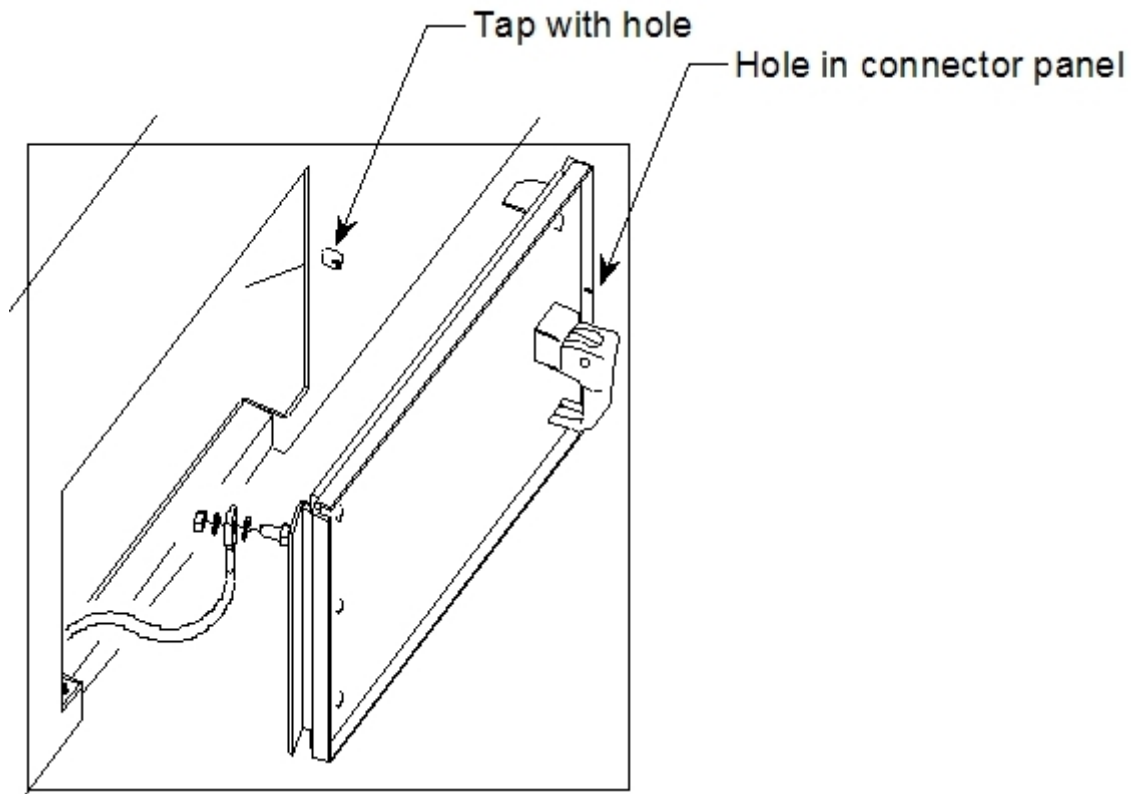

(a) Typical Sealing of CSN210 Dimensioning Unit Connector Panel Cover

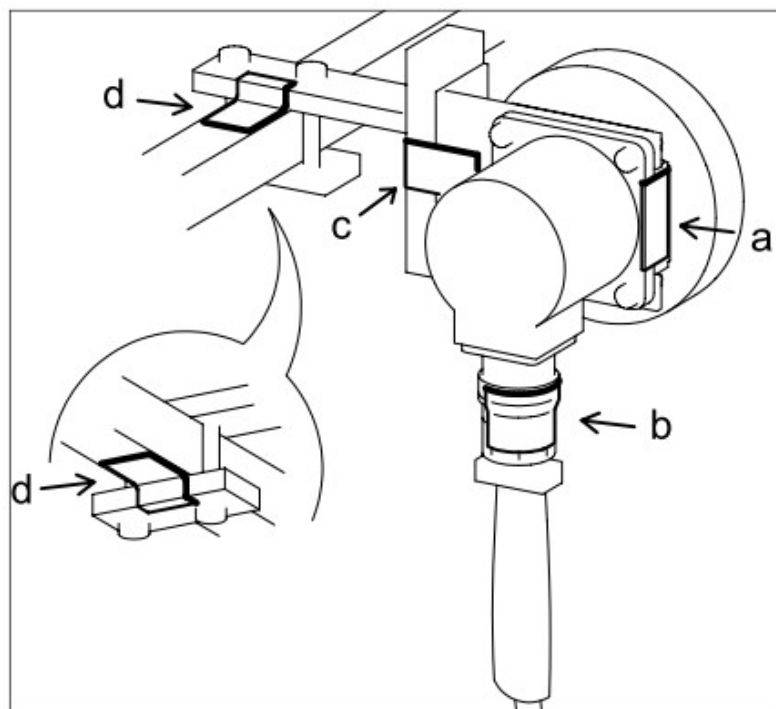

(b) Typical Sealing of Pulse Generator

Toledo Cargoscan Model CSN210.2 *Massflow*™ Dimensional Measuring
Instrument Including Typical Sealing

FIGURE 13/1/22 – 3



(a) Typical Display of a METTLER TOLEDO Model CS2200LX Indicator

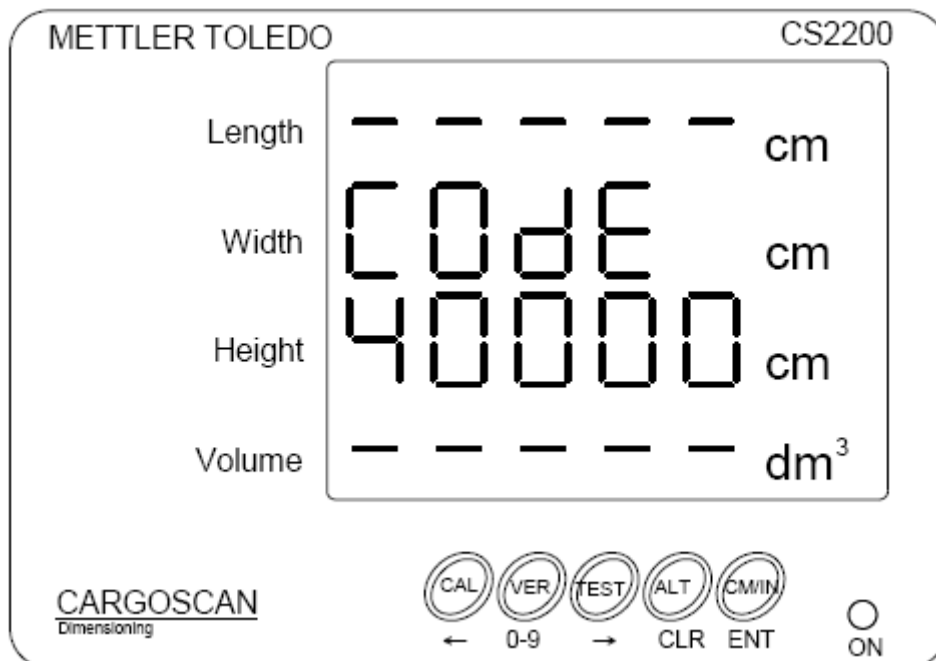

(b) Typical Error Code Display

FIGURE 13/1/22 – 4



Optional Mettler Toledo Workstation

~ End of Document ~