

ICS4_6x-series

English Quick Guide **ICS4_6x-series** Explosion-protected weighing solutions

Deutsch Kurzanleitung **ICS4_6x-Serie** Explosionsgeschützte Wägelösungen

Français Guide rapide **Série ICS4_6x** Solutions de pesage protégée contre les explosions

Español Guía rápida **Serie ICS4_6x** Soluciones de pesada a prueba de explosión

Italiano Guida rapida **Serie ICS4_6x** Soluzioni di pesata con protezione anti-deflagrante

Nederlands Snelgids **ICS4_6x-serie** Explosie veilige weegoplossingen

Português Guia rápido **Série ICS4_6x** Sistemas de pesagem protegida contra explosão

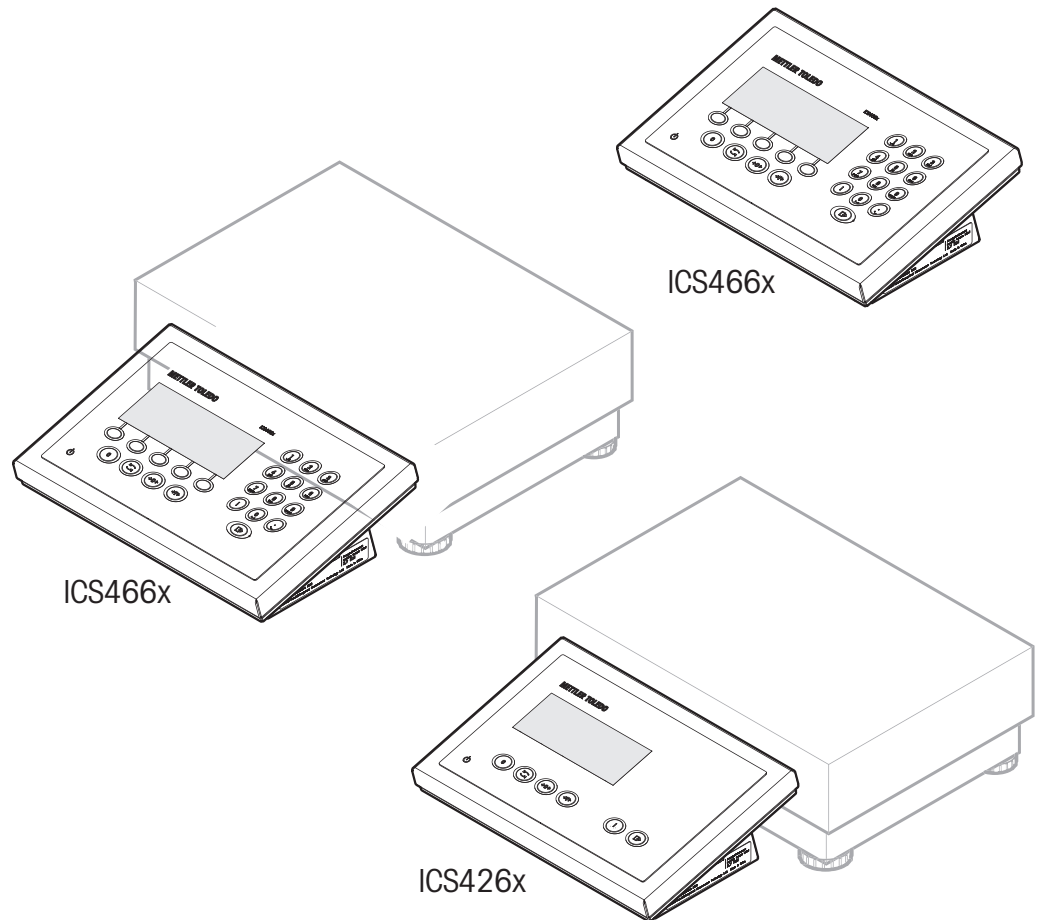

METTLER TOLEDO

METTLER TOLEDO Service

Congratulations on choosing the quality and precision of METTLER TOLEDO. Proper use of your new equipment according to this Manual and regular calibration and maintenance by our factory-trained service team ensures dependable and accurate operation, protecting your investment. Contact us about a service agreement tailored to your needs and budget. Further information is available at www.mt.com/service

There are several important ways to ensure you maximize the performance of your investment:

- 1 **Register your product:** We invite you to register your product at www.mt.com/productregistration so we can contact you about enhancements, updates and important notifications concerning your product.
- 2 **Contact METTLER TOLEDO for service:** The value of a measurement is proportional to its accuracy – an out of specification scale can diminish quality, reduce profits and increase liability. Timely service from METTLER TOLEDO will ensure accuracy and optimize uptime and equipment life.
 - ⇒ **Installation, Configuration, Integration and Training:** Our service representatives are factory-trained weighing equipment experts. We make certain that your weighing equipment is ready for production in a cost effective and timely fashion and that personnel are trained for success.
 - ⇒ **Initial Calibration Documentation:** The installation environment and application requirements are unique for every industrial scale so performance must be tested and certified. Our calibration services and certificates document accuracy to ensure production quality and provide a quality system record of performance.
 - ⇒ **Periodic Calibration Maintenance:** A Calibration Service Agreement provides on-going confidence in your weighing process and documentation of compliance with requirements. We offer a variety of service plans that are scheduled to meet your needs and designed to fit your budget.

Table of Contents

1	Safety instructions	3
1.1	Intended use	3
1.2	Misuse	3
1.3	Safety notes for operation in hazardous areas	3
2	Introduction	4
2.1	Weighing terminals of the ICS4_6x-series	4
2.2	About this document	4
2.3	Further documents	4
3	Installation	5
3.1	Installation, configuration service and repair	5
3.2	Leveling	5
4	Operation	6
4.1	Display	6
4.2	Keyboard	8
4.3	Switching on/off	9
4.4	Zeroing	9
4.5	Straight weighing	9
4.6	Taring	10
4.7	Printing or transferring data	10
4.8	Switching weight unit	10
4.9	Counting (ICS466x only)	11
4.10	Over/Under Checkweighing (ICS466x only)	12
4.11	Totalizing (ICS466x only)	13
5	Maintenance	14
5.1	Cleaning	14
5.2	Disposal	14
6	Technical data	15

1 Safety instructions

1.1 Intended use

Weighing terminals of the ICS4_6x-series are part of a modular explosion-protected weighing system consisting of a METTLER TOLEDO weighing terminal as indicator and at least one weighing platform.

Weighing terminals of the ICS4_6x-series are approved for operation in hazardous areas of Category 2 / Division 1.

- Use the weighing terminal only for weighing in accordance with this Quick guide and the corresponding User manual.
- The weighing terminal is intended for indoor use only.
- Any other type of use is considered as not intended.

Legal metrology

- For use in legal metrology, only use approved weighing systems.
- When using in legal metrology, the operating company is responsible for observing all national weights & measurements requirements.
- Please contact the METTLER TOLEDO Service organization for questions related to the use in legal for trade applications.

1.2 Misuse

- Do not use the weighing terminal other than for weighing operations.
- Do not modify the weighing terminal.
- Do not use the weighing terminal beyond the limits of the technical specifications.

1.3 Safety notes for operation in hazardous areas

Weighing terminals of the ICS4_6x-series are approved for operation in Category 2 / Division 1 hazardous areas.

The operating company is responsible for the safe operation of the explosion-protected weighing system.



DANGER

Explosion hazard

- 1 Strictly observe the instructions of the operating company.
- 2 Comply with all national regulations for operation in hazardous areas, as well as the instructions and information in this Quick guide.

2 Introduction

2.1 Weighing terminals of the ICS4_6x-series

This Quick guide focuses on the following weighing terminals:

Type	Numeric keypad	Soft keys	Environment	Terminal and platform combination
ICS426x	–	–	Category 2 / Division 1	with PBK9-/PFK-9 series with option Category 2 / Division 1
ICS466x	x	x		optional, e.g., with PBK9-/PFK-9 series with option Category 2 / Division 1 or PBA430x

Scale interfaces

Weighing terminals of the ICS4_6x-series are available with various scale interfaces. The built-in scale interface is indicated directly after the terminal type.

ICS4_6xa	...d
Scale interface	analog (ICS466x only)	IDNet / SICSpro

2.2 About this document



This document contains all information for the **operator** of the weighing terminals of the ICS4_6x-series.

- Read this document carefully before use.
- Keep this document for future reference.
- Pass this document on to any future owner or user of the product.

2.3 Further documents

In addition to this printed document you can download the following documents from <http://www.mt.com>:

- Operator manuals
- Technical manuals
- Installation manuals
- Data sheets
- Videos
- Brochures
- Type approval documents
- For terminal and platform combinations: User manuals of the connected weighing platforms

Type approval documents

ICS4_6x	Category 2	BVS 13 ATEX E042X IECEX BVS 13.0050X
	Division 1	FM16US00098

3 Installation

3.1 Installation, configuration service and repair

- For installation, configuration, service and repair of an explosion-protected weighing system call the METTLER TOLEDO Service.

3.2 Leveling

ICS4_6x weighing terminals are available as terminal and platform combination.

Only weighing platforms that have been leveled precisely horizontally provide accurate weighing results. Weights and Measures approved weighing platforms have a level bubble to simplify levelling.

- Turn the adjustable feet of the weighing platform until the level bubble's air bubble is inside the inner circle.

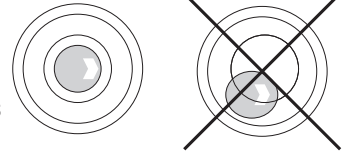

4 Operation

4.1 Display

4.1.1 Default layout

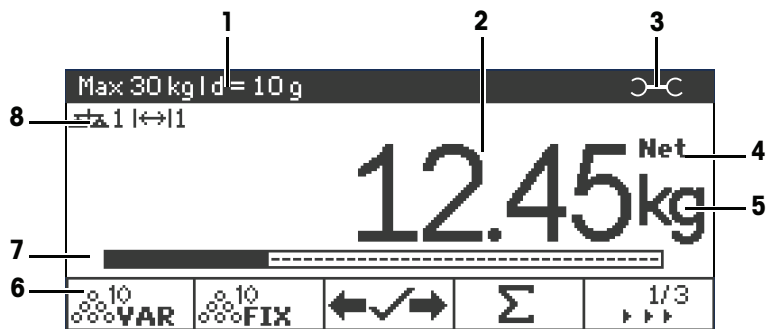

- 1 Metrological data line
- 2 Weight value
- 3 Spanner icon: service needed
- 4 Net/Gross
- 5 Unit
- 6 Soft keys (factory setting, page 1, ICS466x only)
- 7 Auxiliary data line: The contents is defined in the menu, see User manual.
- 8 Symbols and info line

Metrological data line

i The metrological data is stored in the weighing platform. The weighing terminal only serves as indicator.

In the metrological data line, the following information is displayed:

Symbol	Information
	Accuracy classes
W1 , W2 , W3	Weighing range information
Max , cap	Maximum capacity
Min	Minimum capacity
e =	Approved resolution
d =	Display resolution
Approved scale	Approved weighing device
-10 °C ... +40 °C	Temperature range





4.1.2 Weight value

The weight value can be marked with the following symbols:

Symbol	Information
*	Calculated weight value
—	Sign for negative weight values
○	Stability monitor for unstable weight values
1.234₃ kg	Non-approved last digit with $e > d$







4.1.3 Symbols and info line

In the symbols and info line the following information can be displayed. For more symbols, refer to the User manual.

Symbol	Information	Availability
	Scale number	Not for ICS426x
	Weighing range	For multi range or multi interval scales only
	Weight below minimum weight	
	Automatic taring	
	Automatic clearing of the tare weight	
>0<	Center of zero indication	Depending on local Weights and Measures regulations
Σ	Totalization	Not for ICS426x
Fact	Fact needs to be done	Displayed only if the function is supported by the weighing platform, e.g., PBK9-/PFK9-series







4.2 Keyboard

4.2.1 Function keys

Key	Name	Key	Name
	Power		Tare
	Clear		Info
	Switch		Transfer
	Zero		

4.2.2 Main soft keys (ICS466x only)

To meet your specific application requirements, ICS466x weighing terminals offer soft keys which can be configured in the menu. For more soft keys, refer to the User manual.

ICS4_6x	Menu setting	Function
	Ref n var	Determine the average piece weight, freely adjustable
	Ref n fix	Determine the average piece weight, fixed reference sizes
	Weight/count	Switch between weight display and display of pieces
	Totalizing	Start totalizing
	Over/Under Checkweighing	Enter Over/Under Checkweighing parameters
	Save article	Save the current article parameters in the database
	Recall article	Recall parameters from the database

4.3 Switching on/off

Switching on

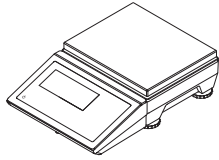

Switching off

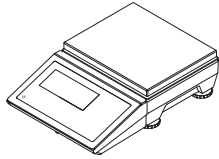

Press and hold  until **OFF** is displayed.

4.4 Zeroing

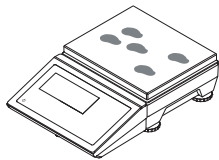

Zeroing corrects the influence of slight changes on the load plate or minor deviations from the zero point.

4.5 Straight weighing

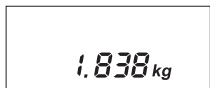
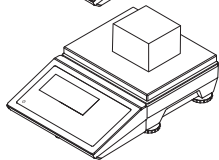
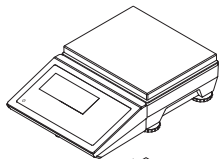

4.6 Taring

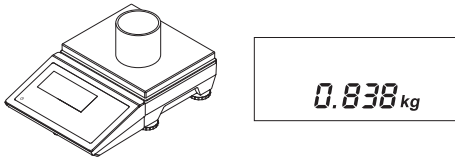

When the scale is tared, the NET symbol is displayed.

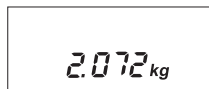
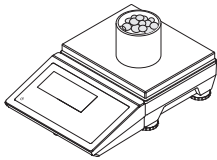

When the tare is cleared, the gross weight is displayed.

4.7 Printing or transferring data

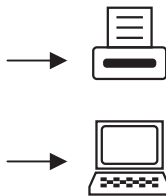
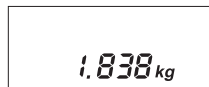
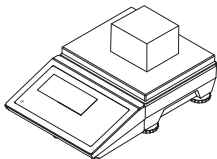

- The printer or computer has to be located in the safe area.
- The data have to be transferred to the safe area via the ACM200 interface converter.

4.8 Switching weight unit

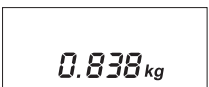
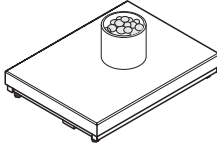

4.9 Counting (ICS466x only)

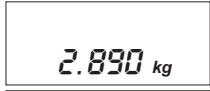
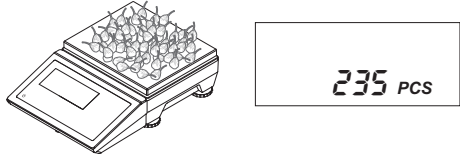
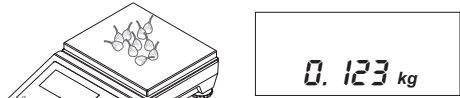
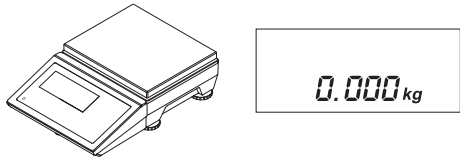

Clearing counting

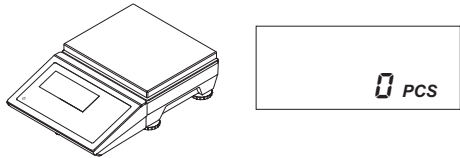

Use the number of reference parts indicated on the soft key, in this example: 10 pieces.

Switch between the display of the number of pieces and of the weight.

Press the **C** key to clear the counting parameters. The weight is displayed.

4.10 Over/Under Checkweighing (ICS466x only)

Setting target values

	<table border="1"> <tr><td>Tol. type:</td><td>Absolute</td></tr> <tr><td>Low:</td><td>0.00 kg</td></tr> <tr><td>High:</td><td>0.00 kg</td></tr> </table>	Tol. type:	Absolute	Low:	0.00 kg	High:	0.00 kg
Tol. type:	Absolute						
Low:	0.00 kg						
High:	0.00 kg						
	<table border="1"> <tr><td>Tol. type:</td><td>Absolute</td></tr> <tr><td>Low:</td><td>0.00 kg</td></tr> <tr><td>High:</td><td>0.00 kg</td></tr> </table>	Tol. type:	Absolute	Low:	0.00 kg	High:	0.00 kg
Tol. type:	Absolute						
Low:	0.00 kg						
High:	0.00 kg						
	<table border="1"> <tr><td>Tol. type:</td><td>Absolute</td></tr> <tr><td>Low:</td><td>9.5 kg</td></tr> <tr><td>High:</td><td>0.00 kg</td></tr> </table>	Tol. type:	Absolute	Low:	9.5 kg	High:	0.00 kg
Tol. type:	Absolute						
Low:	9.5 kg						
High:	0.00 kg						
	<table border="1"> <tr><td>Tol. type:</td><td>Absolute</td></tr> <tr><td>Low:</td><td>9.5 kg</td></tr> <tr><td>High:</td><td>0.00 kg</td></tr> </table>	Tol. type:	Absolute	Low:	9.5 kg	High:	0.00 kg
Tol. type:	Absolute						
Low:	9.5 kg						
High:	0.00 kg						
	<table border="1"> <tr><td>Tol. type:</td><td>Absolute</td></tr> <tr><td>Low:</td><td>9.5 kg</td></tr> <tr><td>High:</td><td>10.4 kg</td></tr> </table>	Tol. type:	Absolute	Low:	9.5 kg	High:	10.4 kg
Tol. type:	Absolute						
Low:	9.5 kg						
High:	10.4 kg						
	<table border="1"> <tr><td colspan="2">New target set!</td></tr> </table>	New target set!					
New target set!							
<table border="1"> <tr><td>LW: 9.50kg</td><td>HI: 10.40kg</td></tr> </table>		LW: 9.50kg	HI: 10.40kg				
LW: 9.50kg	HI: 10.40kg						

For other tolerance types, refer to the User manual.

You can either weigh the target weight or enter it numerically.

Over/Under Checkweighing display

	Weight within the tolerances
	Weight above the tolerances
	Weight below the tolerances

Leaving Over/Under Checkweighing

- esc** Leave Over/Under Checkweighing, but keep the target values.
- C** Leave Over/Under Checkweighing and clear target values.

4.11 Totalizing (ICS466x only)

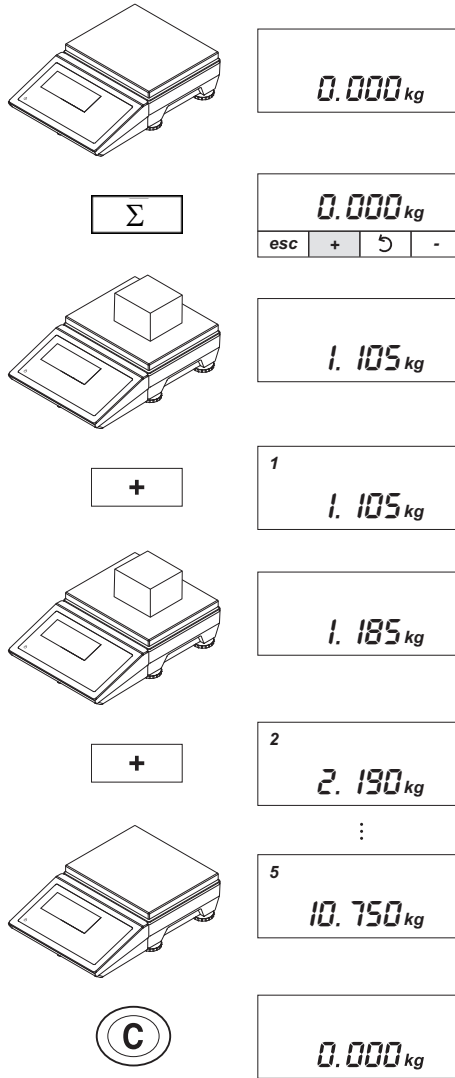

The totalizing soft keys are displayed.

1st item totalized.

Unload the scale and place the 2nd item.

2nd item totalized.

5 items totalized and last item removed.

Total cleared.

5 Maintenance

Maintenance of the weighing terminal is limited to regular cleaning.

5.1 Cleaning



WARNING

Explosion hazard

- 1 Strictly observe the instructions of the operating company.
- 2 Avoid electrostatic charging by wearing suitable working clothes when operating in hazardous areas.

Notes on cleaning

- Only use a clean damp cloth and gently wipe the keypad.
- Use water or mild, non-abrasive cleaning agents.
- Do not spray cleaner directly on the weighing terminal.
- Do not use any acids, alkalis or strong solvents.
- Do not clean the weighing terminal using high-pressure or high-temperature water.
- Observe all existing regulations on cleaning intervals and permissible cleaning agents.
- Do not use compressed air or vacuum.
- Remove dust layers.

5.2 Disposal

In accordance with the requirements of European Directive 2002/96 EC on Waste Electrical and Electronic Equipment (WEEE), this device may not be disposed of with domestic refuse. This also applies for countries outside the EU in accordance with their respective national regulations.

- Please dispose of this product in accordance with local regulations for the separate collection of waste electrical and electronic equipment.



Should you have any questions, please contact the corresponding authorities or the dealer from whom this device was purchased.

If this device is passed on (for example for further private or commercial/industrial use), this regulation is also to be passed on.

Many thanks for your contribution to the protection of the environment.

6 Technical data

Weighing terminals		ICS426x	ICS466x
Housing		Stainless steel	
Display		Monochrome LCD graphical display Backlighting	Monochrome LCD graphical display Colored backlighting
Keyboard		Tactile touch membrane keypad (PET), scratch-resistant labeling	
Net weight		2.8 kg / 6.1 lb	
Protection type		IP65	
Mains connection		via APS768x	
Ambient conditions	Application	indoor use only	
	Temperature range Class III	-10 °C ... 40 °C / 14 °F ... 104 °F	
	Humidity	Max. rel. humidity 85 %, for temperatures up to 40 °C / 104 °F	
Ignition protection type	EN/IECEX	II 2G Ex ib IIC T4 Gb, -10 °C ... + 40 °C II 2D Ex ib IIIC T60°C Db IP65	
	cFM _{US}	IS Class I, II, III; Division 1 Group A, B, C, D, E, F, G; T4; Ta = 40 °C Aex ib IIC T4; IP65; Type 4	
W & M approvals		OIML Class II, III, IIII NTEP Class II, III	
Interfaces		1 interface RS232-IS and 1 scale interface integrated 1 additional optional communication interface	1 interface RS232-IS and 1 scale interface integrated 1 additional optional communication interface 1 additional optional scale interface
Applications		Straight weighing Average weighing Clever print	Straight weighing Average weighing Clever print Over/Under Checkweighing Counting Totalizing Database Prompting Alibi Memory

Analog scale interface (ICS466x only)	
Impedance	80 ... 3,000 Ohms
Excitation	3.3 V
Sensitivity	up to 3 mV/V
Max. resolution	10,000 e (OIML) 300,000 d (non approvable)
Min. verification interval	0.26 μ V/e

Dimensional drawing ICS4_6x-series

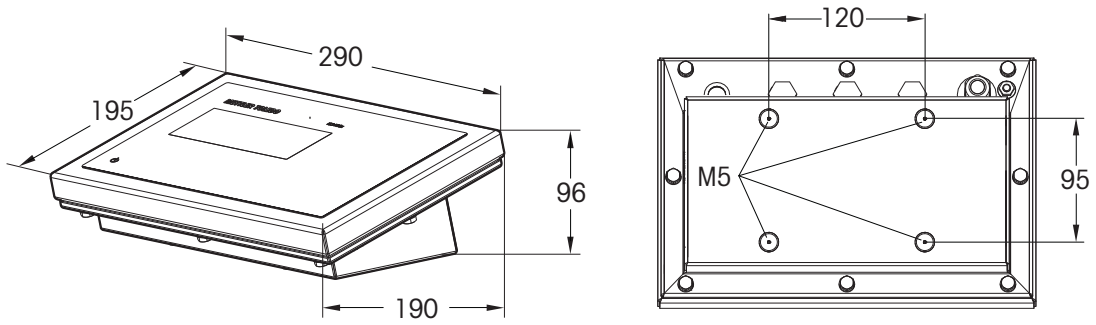

METTLER TOLEDO Service

Herzlichen Glückwunsch zu Ihrer Wahl der Qualität und Präzision von METTLER TOLEDO. Der ordnungsgemäße Gebrauch Ihres neuen Geräts gemäß dieses Handbuchs sowie die regelmäßige Kalibrierung und Wartung durch unser im Werk geschultes Serviceteam gewährleisten den zuverlässigen und genauen Betrieb und schützen somit Ihre Investition. Setzen Sie sich mit uns in Verbindung, wenn Sie an einem Service-Vertrag interessiert sind, der genau auf Ihre Anforderungen und Ihr Budget zugeschnitten ist. Weitere Informationen erhalten Sie unter

www.mt.com/service

Zur Optimierung des Nutzens, den Sie aus Ihrer Investition ziehen, sind mehrere wichtige Schritte erforderlich:

- 1 **Registrierung des Produkts:** Wir laden Sie dazu ein, Ihr Produkt unter www.mt.com/productregistration zu registrieren, damit wir Sie über Verbesserungen, Updates und wichtige Mitteilungen bezüglich Ihres Produkts informieren können.
- 2 **Kontaktaufnahme mit METTLER TOLEDO zwecks Service:** Der Wert einer Messung steht im direkten Verhältnis zu ihrer Genauigkeit – eine nicht den Spezifikationen entsprechende Waage kann zu Qualitätsminderungen, geringeren Gewinnen und einem höheren Haftbarkeitsrisiko führen. Fristgerechte Serviceleistungen von METTLER TOLEDO stellen die Genauigkeit sicher, reduzieren Ausfallzeiten und verlängern die Gerätelebensdauer.
 - ⇒ **Installation, Konfiguration, Integration und Schulung:** Unsere Servicevertreter sind vom Werk geschulte Experten für Wägeausrüstungen. Wir stellen sicher, dass Ihre Wägegeräte auf kostengünstige und termingerechte Weise für den Einsatz in der Produktionsumgebung bereit gemacht werden und dass das Bedienungspersonal so geschult wird, dass ein Erfolg gewährleistet ist.
 - ⇒ **Erstkalibrierungsdokumentation:** Die Installationsumgebung und Anwendungsanforderungen sind für jede Industriewaage anders; deshalb muss die Leistung geprüft und zertifiziert werden. Unsere Kalibrierungsservices und Zertifikate dokumentieren die Genauigkeit, um die Qualität der Produktion sicherzustellen und für erstklassige Aufzeichnungen der Leistung zu sorgen.
 - ⇒ **Periodische Kalibrierungswartung:** Ein Kalibrierungsservicevertrag bildet die Grundlage für Ihr Vertrauen in Ihr Wägeverfahren und stellt gleichzeitig eine Dokumentation der Einhaltung von Anforderungen bereit. Wir bieten eine Vielzahl von Serviceprogrammen an, die auf Ihre Bedürfnisse und Ihr Budget maßgeschneidert werden können.

Inhaltsverzeichnis

1	Sicherheitshinweise	3
1.1	Vorgesehene Nutzung	3
1.2	Missbräuchliche Verwendung	3
1.3	Sicherheitshinweise für den Betrieb in explosionsgefährdeten Bereichen	3
2	Einführung	4
2.1	Wägeterminals der ICS4_6x-Serie	4
2.2	Zu diesem Dokument	4
2.3	Weitere Dokumente	4
3	Installation	5
3.1	Installation, Konfiguration, Service und Reparatur	5
3.2	Nivellieren	5
4	Betrieb	6
4.1	Anzeige	6
4.2	Tastatur	8
4.3	Ein-/Ausschalten	9
4.4	Nullstellen	9
4.5	Direktes Wiegen	9
4.6	Tarieren	10
4.7	Daten drucken oder übertragen	10
4.8	Gewichtseinheit wechseln	10
4.9	Zählen (nur ICS466x)	11
4.10	Plus/Minus-Kontrollwägen (nur ICS466x)	12
4.11	Aufsummieren (nur ICS466x)	13
5	Wartung	14
5.1	Reinigung	14
5.2	Entsorgung	14
6	Technische Daten	15

1 Sicherheitshinweise

1.1 Vorgesehene Nutzung

Wägeterminals der ICS4_6x-Serie sind Teil eines modularen, explosionsgeschützten Wägesystems, bestehend aus einem METTLER TOLEDO Wägeterminal als Anzeige und mindestens einer Wägebrücke.

Wägeterminals der ICS4_6x-Serie sind zugelassen für den Betrieb in explosionsgefährdeten Bereichen der Kategorie 2 / Division 1.

- Dieses Wägeterminal darf nur für Wägungen in Übereinstimmung mit dieser Kurzanleitung und der entsprechenden Bedienungsanleitung verwendet werden.
- Das Wägeterminal ist nur zur Verwendung im Innenbereich bestimmt.
- Jede andere Art der Verwendung gilt als nicht bestimmungsgemäß.

Eichpflichtiger Verkehr

- Für eine Verwendung im eichpflichtigen Verkehr nur geeichte Wägesysteme verwenden.
- Bei einer Verwendung im eichpflichtigen Verkehr ist der Betreiber für die Einhaltung aller nationalen Vorschriften in Bezug auf Maße und Gewichte zuständig.
- Wenden Sie sich bei Fragen bezüglich des Einsatzes in eichpflichtigen Anwendungen an die METTLER TOLEDO Serviceorganisation.

1.2 Missbräuchliche Verwendung

- Das Wägeterminal ausschließlich für Wägevorgänge verwenden.
- Keine Änderungen am Wägeterminal vornehmen.
- Das Wägeterminal nicht für den Betrieb außerhalb der in den technischen Daten vorgegebenen Grenzen verwenden.

1.3 Sicherheitshinweise für den Betrieb in explosionsgefährdeten Bereichen

Wägeterminals der ICS4_6x-Serie sind zugelassen für den Betrieb in explosionsgefährdeten Bereichen der Kategorie 2 / Division 1.

Der Betreiber ist für den sicheren Betrieb des explosionsgeschützten Wägesystems verantwortlich.



GEFAHR

Explosionsgefahr

- 1 Die Anweisungen des Betreibers sind strikt zu befolgen.
- 2 Alle nationalen Vorschriften zum Betrieb in explosionsgefährdeten Bereichen sowie die Anleitungen und Informationen in dieser Kurzanleitung sind einzuhalten.

2 Einführung

2.1 Wägeterminals der ICS4_6x-Serie

In dieser Kurzanleitung wird der Schwerpunkt auf die folgenden Wägeterminals gelegt:

Typ	Numerische Tastatur	Belegbare Funktions-tasten	Umgebung	Komplettwaage
ICS426x	–	–	Kategorie 2 / Division 1	mit PBK9-/PFK-9-Serie mit Option Kategorie 2 / Division 1
ICS466x	x	x		optional, z. B. mit PBK9-/PFK-9-Serie mit Option Kategorie 2 / Division 1 oder PBA430x

Waagenschnittstellen

Wägeterminals der ICS4_6x-Serie sind mit verschiedenen Waagenschnittstellen verfügbar. Die Art der eingebauten Waagenschnittstelle ist direkt hinter dem Terminaltyp angegeben.

ICS4_6xa	...d
Waagenschnittstelle	analog (nur ICS466x)	IDNet / SICSprö

2.2 Zu diesem Dokument



Dieses Dokument enthält alle Informationen für den **Bediener** von Wägeterminals der ICS4_6x-Serie.

- Dieses Dokument vor der Verwendung sorgfältig durchlesen.
- Dieses Dokument für künftige Referenzzwecke aufbewahren.
- Dieses Dokument an künftige Eigentümer oder Benutzer des Produkts weitergeben.

2.3 Weitere Dokumente

Außer dieser Bedienungsanleitung in Druckform können Sie über <http://www.mt.com> die folgenden Dokumente herunterladen:

- Bedienerhandbücher
- Technische Handbücher
- Installationsanleitungen
- Datenblätter
- Videos
- Broschüren
- Dokumente zur Bauartzulassung
- Für Komplettwaagen: Bedienungsanleitungen der angeschlossenen Wägebrücken

Dokumente zur Bauartzulassung

ICS4_6x	Kategorie 2	BVS 13 ATEX E042X IECEX BVS 13.0050X
	Division 1	FM16US00098

3 Installation

3.1 Installation, Konfiguration, Service und Reparatur

- Wenden Sie sich für Installation, Konfiguration, Service und Reparatur eines explosionsgeschützten Wägesystems an den METTLER TOLEDO Service.

3.2 Nivellieren

ICS4_6x-Wägeterminals sind als Komplettwaage verfügbar.

Nur exakt horizontal ausgerichtete Wägebrücken liefern genaue Wägere-sultate. Eichfähige Wägebrücken verfügen über eine Libelle, um das Nivel-lieren zu vereinfachen.

- Die Stellfüße der Wägebrücke drehen, bis die Luftblase der Libelle im inneren Kreis liegt.

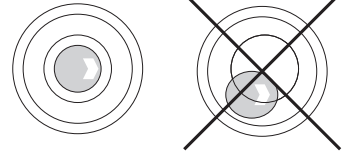

4 Betrieb

4.1 Anzeige

4.1.1 Standardlayout

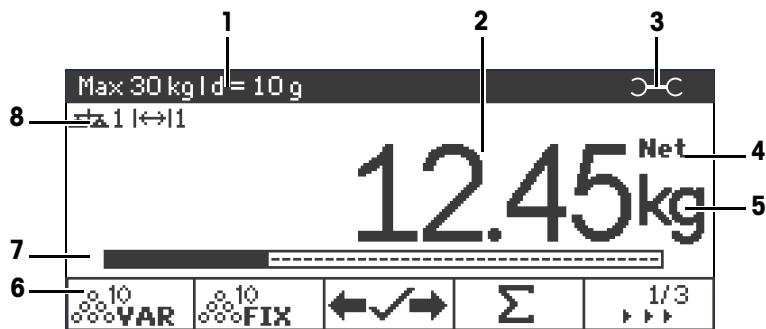

- 1 Zeile für Metrologiedaten
- 2 Gewichtswert
- 3 Schraubenschlüsselsymbol: Servicearbeiten erforderlich
- 4 Netto/Brutto
- 5 Einheit
- 6 Belegbare Funktionstasten (Werkseinstellung, Seite 1, nur ICS466x)
- 7 Zusatzdaten-Zeile: Der Inhalt wird im Menü definiert, siehe die Bedienungsanleitung.
- 8 Symbol- und Info-Zeile

Metrologiedaten-Zeile

i Die Metrologiedaten werden in der Wägebrücke gespeichert. Das Wägeterminal dient nur als Anzeigerät.

In der Zeile für Metrologiedaten werden die folgenden Informationen angezeigt:

Symbol	Information
	Genauigkeitsklassen
W1 , W2 , W3	Information zum Wägebereich
Max , cap	Maximale Kapazität
Min	Minimale Kapazität
e =	Geeichte Auflösung
d =	Auflösung der Anzeige
Approved scale	Geeichtes Wäegerät
-10 °C ... +40 °C	Temperaturbereich





4.1.2 Gewichtswert

Der Gewichtswert kann mit folgenden Symbolen markiert sein:

Symbol	Information
*	Berechneter Gewichtswert
—	Vorzeichen für negative Gewichtswerte
○	Stillstandskontrolle für unstabile Gewichtswerte
1.234₃ kg	Nicht geeichte letzte Ziffer, falls $e > d$







4.1.3 Symbol- und Info-Zeile

In der Symbol- und Info-Zeile können folgende Informationen angezeigt werden. Für weitere Symbole siehe die Bedienungsanleitung.

Symbol	Information	Verfügbarkeit
	Waagennummer	Nicht für ICS426x
	Wägebereich	Nur für Mehrbereichs- oder Mehrteilungs- waagen
	Gewicht unter Mindestgewicht	
	Automatisches Trieren	
	Automatische Taralöschung	
>0<	Nullanzeige	Von den lokalen Eichbestimmungen abhängig
Σ	Aufsummieren	Nicht für ICS426x
Fact	FACT muss ausgeführt werden	Wird nur angezeigt, wenn die Funktion von der Wägebrücke unterstützt wird, z. B. PBK9-/PFK9-Serie







4.2 Tastatur

4.2.1 Funktionstasten

Taste	Name	Taste	Name
	Strom		Tara
	Löschen		Info
	Umschalten		Transfer
	Null		

4.2.2 Belegbare Hauptfunktionstasten (nur ICS466x)

Um Ihre speziellen Applikationsanforderungen zu erfüllen, bieten die Wägeterminals ICS466x belegbare Funktionstasten, die im Menü konfiguriert werden können. Für weitere belegbare Funktionstasten siehe die Bedienungsanleitung.

ICS4_6x	Menüeinstellung	Funktion
	Ref N var	Das durchschnittliche Stückgewicht bestimmen, frei einstellbar
	Ref N fix	Das durchschnittliche Stückgewicht bestimmen, feste Referenzgrößen
	Gewicht/Zählen	Zwischen Anzeige des Gewichts und Anzeige der Stücke umschalten
	Aufsummieren	Aufsummieren starten
	Plus/Minus-Kontrollwägen	Parameter für Plus/Minus-Kontrollwägen eingeben
	Artikel speichern	Die aktuellen Artikelparameter in der Datenbank speichern
	Artikel aufrufen	Parameter aus der Datenbank aufrufen

4.3 Ein-/Ausschalten

Einschalten

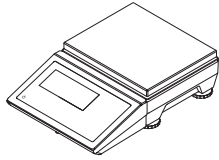

Ausschalten

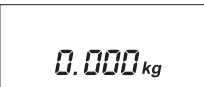
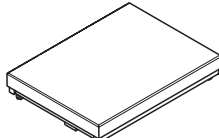

 drücken und halten, bis **AUS** angezeigt wird.

4.4 Nullstellen

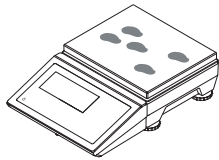

Nullstellen korrigiert den Einfluss leichter Verschmutzungen auf der Lastplatte bzw. kleine Abweichungen vom Nullpunkt.

4.5 Direktes Wiegen

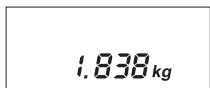
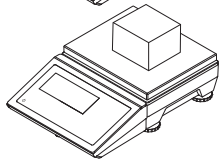
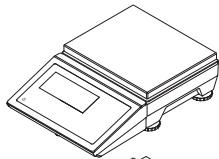

4.6 Trieren

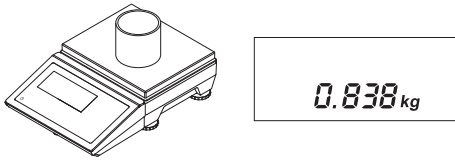

Beim Trieren der Waage wird das Symbol NET angezeigt.

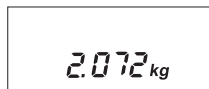
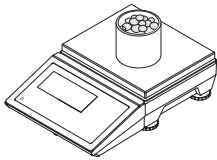

Wenn das Taragewicht gelöscht wird, zeigt die Waage das Bruttogewicht an.

4.7 Daten drucken oder übertragen

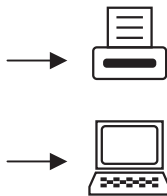
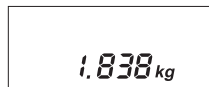
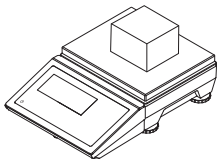

- Der Drucker oder Computer muss im sicheren Bereich aufgestellt sein.
- Die Daten müssen über den Schnittstellenwandler ACM200 in den sicheren Bereich übertragen werden.

4.8 Gewichtseinheit wechseln

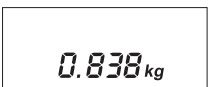
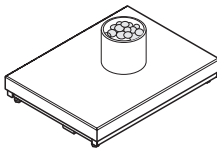

4.9 Zählen (nur ICS466x)

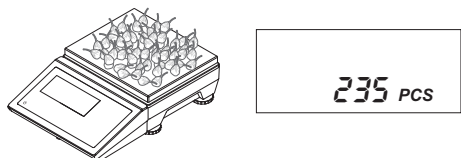
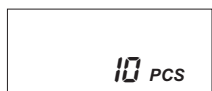
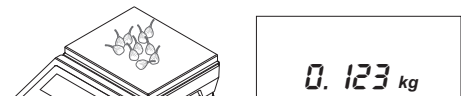
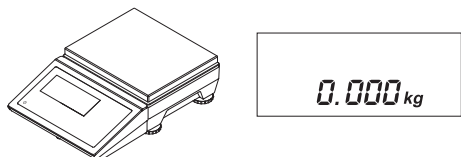

Zählen löschen

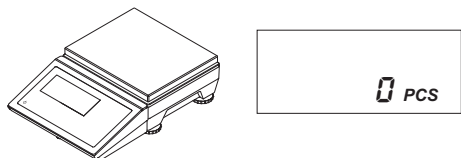







Die auf der belegbaren Funktionstaste angezeigte Anzahl an Referenzteilen verwenden, in diesem Beispiel: 10 Stücke.

Zwischen der Anzeige der Anzahl an Teilen und der Anzeige des Gewichts umschalten.

Taste **C** zum Löschen der Zählparameter drücken. Das Gewicht wird angezeigt.

4.10 Plus/Minus-Kontrollwägen (nur ICS466x)

Zielwerte einstellen



	Tol.-Typ: Absolut Niedrig: 0.00 kg Hoch: 0.00 kg
	Tol.-Typ: Absolut Niedrig: 0.00 kg Hoch: 0.00 kg
	Tol.-Typ: Absolut Niedrig: 9.5 kg Hoch: 0.00 kg
	Tol.-Typ: Absolut Niedrig: 9.5 kg Hoch: 0.00 kg
	Tol.-Typ: Absolut Niedrig: 9.5 kg Hoch: 10.4 kg
	Neues Ziel wurde gesetzt!

LW: 9.50kg
HI: 10.40kg

Für weitere Toleranztypen siehe die Bedienungsanleitung.

Sie können das Zielgewicht entweder wiegen oder es numerisch eingeben.

Anzeige für Plus/Minus-Kontrollwägen

 <p>LW: 9.50kg HI: 10.40kg</p>	Gewicht innerhalb der Toleranzen
 <p>LW: 9.50kg HI: 10.40kg</p>	Gewicht über den Toleranzen
 <p>LW: 9.50kg HI: 10.40kg</p>	Gewicht unter den Toleranzen

Plus/Minus-Kontrollwägen verlassen

- ESC** Plus/Minus-Kontrollwägen verlassen, aber Zielwerte beibehalten.
- C** Plus/Minus-Kontrollwägen verlassen und Zielwerte löschen.

4.11 Aufsummieren (nur ICS466x)

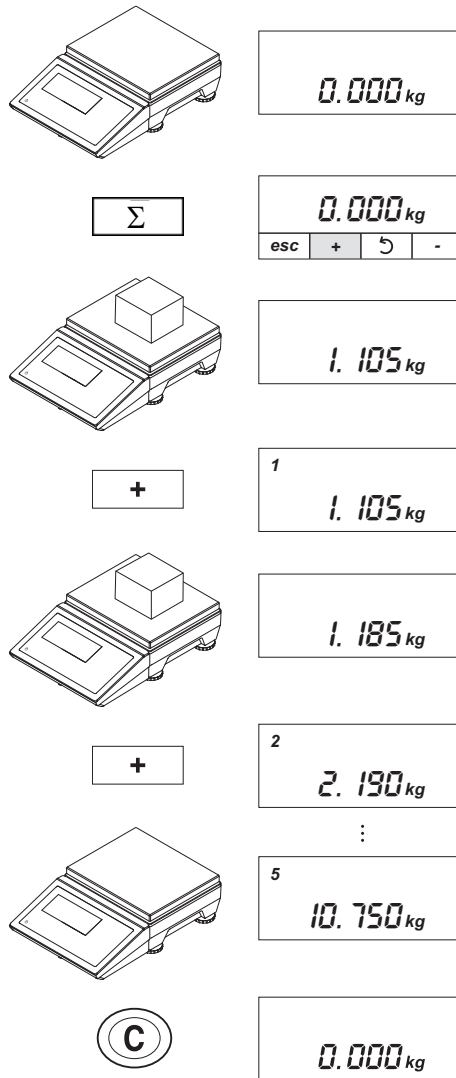

Die belegbaren Funktionstasten für das Aufsummieren werden angezeigt.

Erster Artikel aufsummiert.

Waage entlasten und den zweiten Artikel auflegen.

Zweiter Artikel aufsummiert.

5 Artikel aufsummiert und den letzten Artikel entfernt.

Summe gelöscht.

5 Wartung

Die Wartung des Wägeterminals beschränkt sich auf die regelmäßige Reinigung.

5.1 Reinigung



WARNUNG

Explosionsgefahr

- 1 Die Anweisungen des Betreibers sind strikt zu befolgen.
- 2 Bei der Bedienung im explosionsgefährdeten Bereich geeignete Arbeitskleidung tragen, um elektrostatische Aufladung zu verhindern.

Hinweise zur Reinigung

- Die Tastatur mit einem sauberen feuchten Lappen vorsichtig reinigen.
- Wasser oder milde, abriebbeständige Reinigungsmittel verwenden.
- Reinigungsmittel nicht direkt auf das Wägeterminal sprühen.
- Keine Säuren, Laugen oder starke Lösungsmittel verwenden.
- Das Wägeterminal nicht mit Hochdruck- oder Hochtemperaturwasser reinigen.
- Alle bestehenden Vorschriften bezüglich Reinigungsintervallen und zulässigen Reinigungsmitteln beachten.
- Keine Druckluft oder Staubsauger verwenden.
- Staubablagerungen entfernen.

5.2 Entsorgung

In Übereinstimmung mit den Anforderungen der Europäischen Richtlinie 2002/96 EG über Elektro- und Elektronik-Altgeräte (WEEE) darf dieses Gerät nicht mit dem Hausmüll entsorgt werden. Dies gilt auch für Länder außerhalb der EU entsprechend den geltenden nationalen Bestimmungen.

- Entsorgen Sie dieses Produkt gemäß den örtlichen Bestimmungen für die getrennte Sammlung von Elektro- und Elektronikgeräten.



Bei Fragen wenden Sie sich an die zuständigen Behörden oder an den Händler, bei dem Sie dieses Gerät erworben haben.

Bei Weitergabe dieses Geräts (z. B. für künftige private oder kommerzielle/industrielle Verwendung) muss diese Vorschrift ebenfalls weitergegeben werden.

Wir danken Ihnen für Ihren Beitrag zum Umweltschutz.

6 Technische Daten

Wägeterminals		ICS426x	ICS466x
Gehäuse		Edelstahl	
Anzeige		Monochrome LCD-Grafikanzeige Hinterleuchtung	Monochrome LCD-Grafikanzeige Farbige Hinterleuchtung
Tastatur		Berührungsempfindliche Membrantastatur (PET), kratzfeste Beschriftung	
Nettogewicht		2,8 kg / 6,1 lb	
Schutzgrad		IP65	
Netzanschluss		über APS768x	
Umgebungsbedingungen	Verwendung	Nur zur Verwendung im Innenbereich	
	Temperaturbereich Klasse III	-10 °C ... 40 °C / 14 °F ... 104 °F	
	Feuchtigkeit	Max. rel. Feuchtigkeit 85 % für Temperaturen bis zu 40 °C / 104 °F	
Zündschutzart	EN/IECEX	II 2G Ex ib IIC T4 Gb, -10 °C ... +40 °C II 2D Ex ib IIIC T60°C Db IP65	
	cFM _{US}	IS Klasse I, II, III; Division 1 Gruppe A, B, C, D, E, F, G; T4; Ta = 40 °C Aex ib IIC T4; IP65; Typ 4	
Eichzulassungen		OIML Klasse II, III, IIII NTEP Klasse II, III	
Schnittstellen		1 RS232-IS-Schnittstelle und 1 Waagenschnittstelle integriert 1 zusätzliche optionale Kommunikationsschnittstelle	1 RS232-IS-Schnittstelle und 1 Waagenschnittstelle integriert 1 zusätzliche optionale Kommunikationsschnittstelle 1 zusätzliche optionale Waagenschnittstelle
Applikationen		Direktes Wiegen Dynamisches Wiegen Intelligenter Ausdruck	Direktes Wiegen Dynamisches Wiegen Intelligenter Ausdruck Plus/Minus-Kontrollwägen Zählen Aufsummieren Datenbank Auffordern Alibi-Speicher

Analoge Waagenschnittstelle (nur ICS466x)	
Impedanz	80 ... 3.000 Ohm
Ansteuerung	3,3 V
Empfindlichkeit	bis zu 3 mV/V
Max. Auflösung	10.000 e (OIML) 300.000 d (nicht eichfähig)
Min. Eichintervall	0,26 μ V/e

Maßzeichnung ICS4_6x-Serie

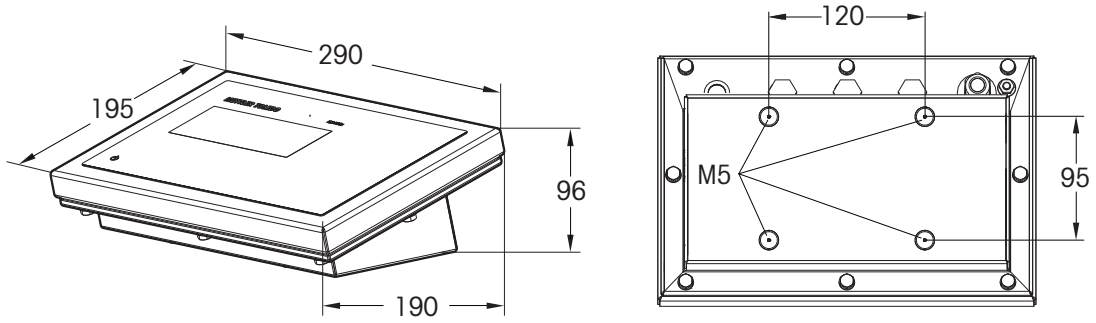

METTLER TOLEDO Service

Nous vous remercions d'avoir sélectionné la qualité et la précision de METTLER TOLEDO. Si vous respectez les instructions stipulées dans ce manuel pour votre nouvel équipement et confiez régulièrement l'étalonnage et la maintenance à notre équipe de service formée à l'usine, vous obtiendrez non seulement une exploitation fiable et précise, mais vous protégerez votre investissement. Consultez-nous pour discuter d'un contrat de service adapté à vos besoins et votre budget. Vous trouverez de plus amples informations à l'adresse suivante:

www.mt.com/service

Il existe plusieurs méthodes garantissant l'optimisation de la performance de votre investissement:

- 1 **Enregistrez votre produit:** Nous vous invitons à enregistrer votre produit à l'adresse www.mt.com/productregistration afin de nous permettre de vous avertir des améliorations, mises à jour et avis importants relatifs à votre produit.
- 2 **Contactez METTLER TOLEDO pour le service:** La valeur d'une mesure est proportionnelle à sa précision. Une balance hors spécification peut affecter la qualité, réduire les revenus et accroître les responsabilités. Le service ponctuel de METTLER TOLEDO garantit la précision et optimise la durée d'exploitation ainsi que la vie utile de l'équipement.
 - ⇒ **Installation, Configuration, Intégration et Formation:** Nos représentants techniques sont des spécialistes des équipements de pesage, formés à l'usine. Nous veillons à ce que l'équipement de pesage soit prêt à la production de manière rentable et ponctuelle et que le personnel soit formé pour optimiser la réussite.
 - ⇒ **Documentation d'étalonnage initial:** Les conditions relatives à l'application et l'environnement de l'installation sont différentes pour toutes les balances industrielles de sorte que la performance doit être testée et certifiée. Nos services d'étalonnage et les certificats documentent la précision afin de garantir la qualité de la production et fournir un enregistrement du système de qualité sur la performance.
 - ⇒ **Maintenance périodique de l'étalonnage:** Un Accord de service d'étalonnage favorise la confiance continue dans votre processus de pesage et fournit la documentation de conformité aux normes. Nous offrons toute une gamme de programmes de service qui sont préparés pour satisfaire vos besoins et conçus pour correspondre à votre budget.

Table des matières

1	Consignes de sécurité	3
1.1	Destination conforme	3
1.2	Usage abusif	3
1.3	Consignes de sécurité pour le fonctionnement dans des zones dangereuses.....	3
2	Introduction	4
2.1	Terminaux de pesage de la série ICS4_6x	4
2.2	A propos de ce document	4
2.3	Documents connexes	4
3	Installation	5
3.1	Installation, configuration, service après-vente et réparation.....	5
3.2	Mise à niveau.....	5
4	Fonctionnement	6
4.1	Afficheur	6
4.2	Clavier.....	8
4.3	Mise en service et hors service	9
4.4	Réglage du zéro	9
4.5	Pesage direct	9
4.6	Tarage.....	10
4.7	Impression ou transfert de données.....	10
4.8	Commutation de l'unité de poids	10
4.9	Comptage (ICS466x uniquement)	11
4.10	Pesée de contrôle Plus/Moins (ICS466x uniquement)	12
4.11	Totalisation (ICS466x uniquement).....	13
5	Maintenance	14
5.1	Nettoyage	14
5.2	Mise au rebut	14
6	Caractéristiques techniques	15

1 Consignes de sécurité

1.1 Destination conforme

Les terminaux de pesage de la série ICS4_6x font partie d'un système de pesage modulaire protégé contre les explosions constitué d'un terminal de pesage METTLER TOLEDO comme afficheur et d'au moins une plate-forme de pesage.

Les terminaux de pesage de la série ICS4_6x sont homologués pour le fonctionnement dans les zones dangereuses de Catégorie 2 / Division 1.

- Utilisez le terminal de pesage uniquement pour le pesage conformément à ce Guide rapide et au Manuel de l'utilisateur.
- Le terminal de pesage est destiné à un usage intérieur uniquement.
- Tout autre type d'utilisation est considéré comme non conforme.

Métrologie légale

- Pour l'utilisation en métrologie légale, utilisez uniquement des systèmes de pesage homologués.
- Lors de l'utilisation en métrologie légale, l'entreprise d'exploitation est responsable du respect de toutes les exigences nationales de poids & mesures.
- Veuillez contacter le service après-vente METTLER TOLEDO pour les questions relatives aux applications légales pour le commerce.

1.2 Usage abusif

- N'utilisez pas le terminal de pesage pour autre chose que peser des marchandises.
- Ne modifiez pas le terminal de pesage.
- N'utilisez pas le terminal de pesage au-delà des limites des spécifications techniques.

1.3 Consignes de sécurité pour le fonctionnement dans des zones dangereuses

Les terminaux de pesage de la série ICS4_6x sont homologués pour le fonctionnement dans les zones dangereuses de Catégorie 2 / Division 1.

La société d'exploitation est responsable du fonctionnement sûr du système de pesage protégé contre les explosions.



DANGER

Danger d'explosion

- 1 Observez strictement les instructions de la société d'exploitation.
- 2 Respectez toutes les réglementations nationales d'exploitation dans des zones dangereuses, ainsi que les instructions et informations dans ce Guide rapide.

2 Introduction

2.1 Terminaux de pesage de la série ICS4_6x

Ce Guide rapide se concentre sur les terminaux de pesage suivants:

Type	Pavé numérique	Touches de fonction	Environnement	Combinaison de terminal et plate-forme
ICS426x	–	–	Catégorie 2 / Division 1	avec série PBK9-/PFK-9 avec option Catégorie 2 / Division 1
ICS466x	x	x		en option, p. ex. avec série PBK9-/PFK-9 avec option Catégorie 2 / Division 1 ou PBA430x

Interfaces de balances

Les terminaux de pesage de la série ICS4_6x sont disponibles avec diverses interfaces de balance. L'interface de balance intégrée est indiquée directement après le type de terminal.

ICS4_6xa	...d
Interface de balance	analogique (ICS466x unique- ment)	IDNet / SICSpro

2.2 A propos de ce document



Ce document contient toutes les informations pour l'**opérateur** des terminaux de pesage de la série ICS4_6x.

- Lisez ce document attentivement avant l'utilisation.
- Conservez ce document pour consultation future.
- Transmettez ce document à tout propriétaire ou utilisateur ultérieur du produit.

2.3 Documents connexes

En plus de ce document imprimé, vous pouvez télécharger les documents suivants de <http://www.mt.com>:

- Manuels de l'opérateur
- Manuels techniques
- Manuels d'installation
- Fiches techniques
- Vidéos
- Brochures
- Documents d'approbation de type
- Combinaisons de terminal et plate-forme: Manuels de l'utilisateur des plates-formes de pesage connectées

Documents d'approbation de type

ICS4_6x	Catégorie 2	BVS 13 ATEX E042X IECEx BVS 13.0050X
	Division 1	FM16US00098

3 Installation

3.1 Installation, configuration, service après-vente et réparation

- Pour l'installation, la configuration, le service après-vente et la réparation d'un système de pesage protégé contre l'explosion, appelez le service après-vente METTLER TOLEDO.

3.2 Mise à niveau

Les terminaux de pesage ICS4_6x sont disponibles comme combinaison de terminal et plate-forme.

Seules les plates-formes de pesage qui ont été mises à niveau avec précision à l'horizontale fournissent des résultats de pesée précis. Les plates-formes de pesage homologuées par les Poids et Mesures ont un niveau à bulle d'air pour simplifier la mise à niveau.

- Tournez les pieds réglables de la plate-forme de pesage jusqu'à ce que la bulle d'air du niveau à bulle d'air soit positionnée dans le cercle intérieur.

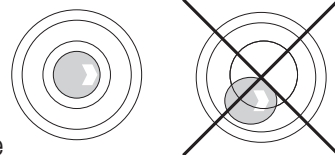

4 Fonctionnement

4.1 Afficheur

4.1.1 Affichage par défaut

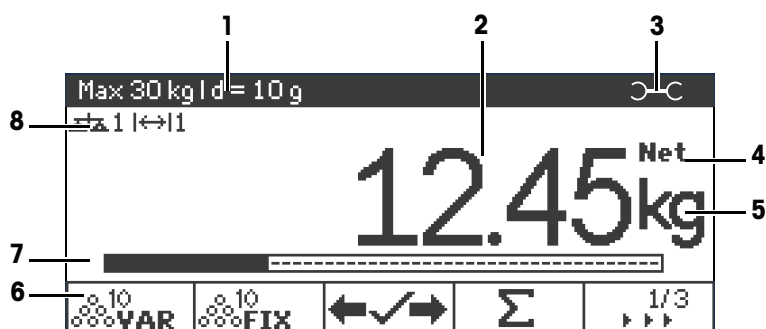

- 1 Ligne de données métrologiques
- 2 Valeur de poids
- 3 Icône de clé: maintenance requise
- 4 Net/Brut
- 5 Unité
- 6 Touches de fonction (réglage d'usine, page 1, ICS466x uniquement)
- 7 Ligne de données auxiliaires: Le contenu est défini dans le menu, voir Manuel de l'utilisateur.
- 8 Ligne de symboles et d'information

Ligne de données métrologiques

i Les données métrologiques sont stockées dans la plate-forme de pesage. Le terminal de pesage sert uniquement d'indicateur.

Dans la ligne de données métrologiques, les informations suivantes sont affichées:

Symbole	Information
	Classes de précision
W1 , W2 , W3	Information de plage de poids
Max , cap	Capacité maximale
Min	Capacité minimale
e =	Résolution homologuée
d =	Résolution d'affichage
Approved scale	Dispositif de pesage homologué
-10 °C ... +40 °C	Plage de température





4.1.2 Valeur de poids

La valeur de poids peut être marquée avec les symboles suivants:

Symbole	Information
*	Valeur de poids calculée
—	Signe pour valeurs de poids négatives
○	Surveillance de stabilité pour valeurs de poids instables
1.234₃ kg	Dernier chiffre non homologué avec $e > d$







4.1.3 Ligne de symboles et d'information

Les informations suivantes peuvent être affichées dans la ligne de symboles et d'information. Pour plus de symboles, voir le Manuel de l'utilisateur.

Symbole	Information	Disponibilité
	N° de la balance	Pas pour ICS426x
<->	Plage de pesée	Pour balances multi range ou multi intervalles uniquement
	Poids inférieur au poids minimum	
	Tarage automatique	
	Effacement automatique de la tare	
>0<	Indication du centre de zéro	Dépend des réglementations locales de Poids et Mesures
Σ	Totalisation	Pas pour ICS426x
Fact	FACT doit être effectué	Affiché uniquement si la fonction est supportée ar la plate-forme de pesage, p. ex., série PBK9-/PFK9







4.2 Clavier

4.2.1 Touches de fonction

Touche	Nom	Touche	Nom
	Puissance		Tare
	Effacer		Info
	Commuter		Transfert
	Zéro		

4.2.2 Touches de fonction principales (ICS466x uniquement)

Pour répondre à vos besoins d'application spécifiques, les terminaux de pesage ICS466x proposent des touches de fonction qui peuvent être configurées dans le menu. Pour plus de touches de fonction, voir le Manuel de l'utilisateur.

ICS4_6x	Réglage du menu	Fonction
	Réf N var	Déterminer le poids moyen à la pièce, librement réglable
	Réf N fix	Déterminer le poids moyen à la pièce, tailles de référence fixe
	Poids/compte	Commuter entre l'affichage de poids et l'affichage de pièces
	Totalisation	Démarrage de la totalisation
	Pesée de contrôle Plus/Moins	Entrer les paramètres de pesée de contrôle Plus/Moins
	Sauvegarder article	Sauvegarder les paramètres de l'article actuel dans la base de données
	Rappeler article	Rappeler les paramètres de la base de données

4.3 Mise en service et hors service

Mise en service

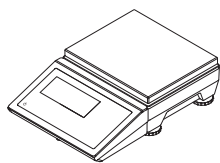

Mise hors service

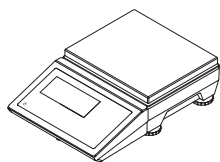

Enfoncez et maintenez enfoncé  jusqu'à ce que **-ARRET-** soit affiché.

4.4 Réglage du zéro

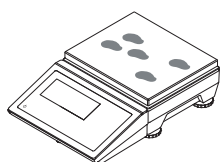

Le réglage du zéro corrige l'influence de légers changements du plateau de charge ou de déviations mineures du zéro.

4.5 Pesage direct

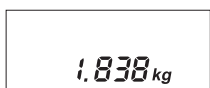
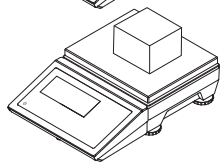
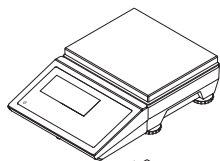

4.6 Tarage

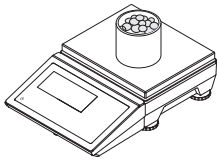
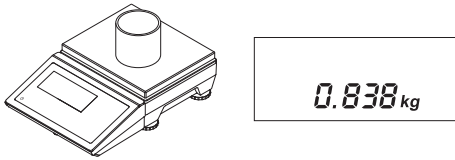

Lorsque la balance est tarée, le symbole NET est affiché.

Lorsque la tare est effacée, le poids brut est affiché.

4.7 Impression ou transfert de données

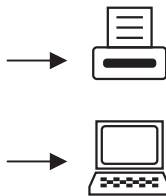
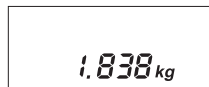
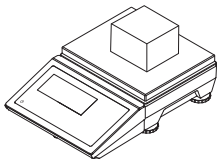

- L'imprimante ou l'ordinateur doivent être situés dans la zone sûre.
- Les données doivent être transférées dans la zone sûre via le convertisseur d'interface ACM200.

4.8 Commutation de l'unité de poids

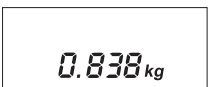
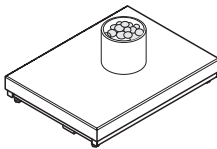

4.9 Comptage (ICS466x uniquement)

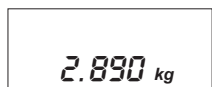
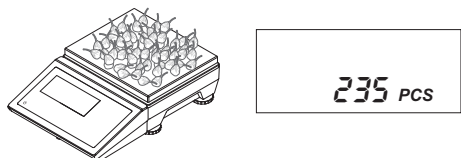
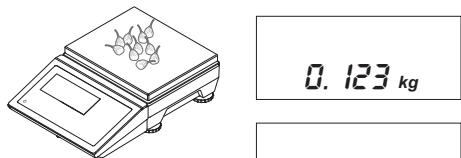
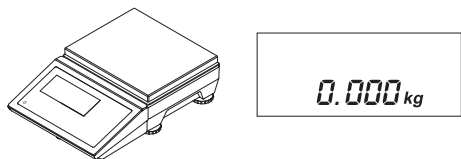

Utilisez le nombre de pièces de référence indiqué sur la touche de fonction, dans cet exemple: 10 pièces.

Commutez entre l'affichage du nombre de pièces et du poids.

Effacement comptage

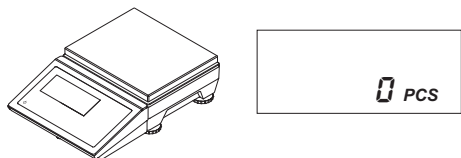

Appuyez sur la touche **C** pour effacer les paramètres de comptage. Le poids est affiché.

4.10 Pesée de contrôle Plus/Moins (ICS466x uniquement)

Définition des valeurs cibles

	<table border="1"> <tr><td>Type tol:</td><td>Absolue</td></tr> <tr><td>Bas:</td><td>0.00 kg</td></tr> <tr><td>Elevée:</td><td>0.00 kg</td></tr> </table>	Type tol:	Absolue	Bas:	0.00 kg	Elevée:	0.00 kg
Type tol:	Absolue						
Bas:	0.00 kg						
Elevée:	0.00 kg						
	<table border="1"> <tr><td>Type tol:</td><td>Absolue</td></tr> <tr><td>Bas:</td><td>0.00 kg</td></tr> <tr><td>Elevée:</td><td>0.00 kg</td></tr> </table>	Type tol:	Absolue	Bas:	0.00 kg	Elevée:	0.00 kg
Type tol:	Absolue						
Bas:	0.00 kg						
Elevée:	0.00 kg						
	<table border="1"> <tr><td>Type tol:</td><td>Absolue</td></tr> <tr><td>Bas:</td><td>9.5 kg</td></tr> <tr><td>Elevée:</td><td>0.00 kg</td></tr> </table>	Type tol:	Absolue	Bas:	9.5 kg	Elevée:	0.00 kg
Type tol:	Absolue						
Bas:	9.5 kg						
Elevée:	0.00 kg						
	<table border="1"> <tr><td>Type tol:</td><td>Absolue</td></tr> <tr><td>Bas:</td><td>9.5 kg</td></tr> <tr><td>Elevée:</td><td>0.00 kg</td></tr> </table>	Type tol:	Absolue	Bas:	9.5 kg	Elevée:	0.00 kg
Type tol:	Absolue						
Bas:	9.5 kg						
Elevée:	0.00 kg						
	<table border="1"> <tr><td>Type tol:</td><td>Absolue</td></tr> <tr><td>Bas:</td><td>9.5 kg</td></tr> <tr><td>Elevée:</td><td>10.4 kg</td></tr> </table>	Type tol:	Absolue	Bas:	9.5 kg	Elevée:	10.4 kg
Type tol:	Absolue						
Bas:	9.5 kg						
Elevée:	10.4 kg						
	<table border="1"> <tr><td colspan="2" style="text-align: center;">Nouvelle cible définie!</td></tr> </table>	Nouvelle cible définie!					
Nouvelle cible définie!							

Pour d'autres types de tolérance, voir le Manuel de l'utilisateur.

Vous pouvez soit peser le poids à atteindre ou l'entrer numériquement.



Affichage de pesée de contrôle Plus/Moins



Poids dans les tolérances



Poids au-dessus des tolérances



Poids en dessous des tolérances

Quitter la pesée de contrôle Plus/Moins

- esc** Quitter la pesée de contrôle Plus/Moins, mais garder les valeurs cibles.
- C** Quitter la pesée de contrôle Plus/Moins et effacer les valeurs cibles.

4.11 Totalisation (ICS466x uniquement)

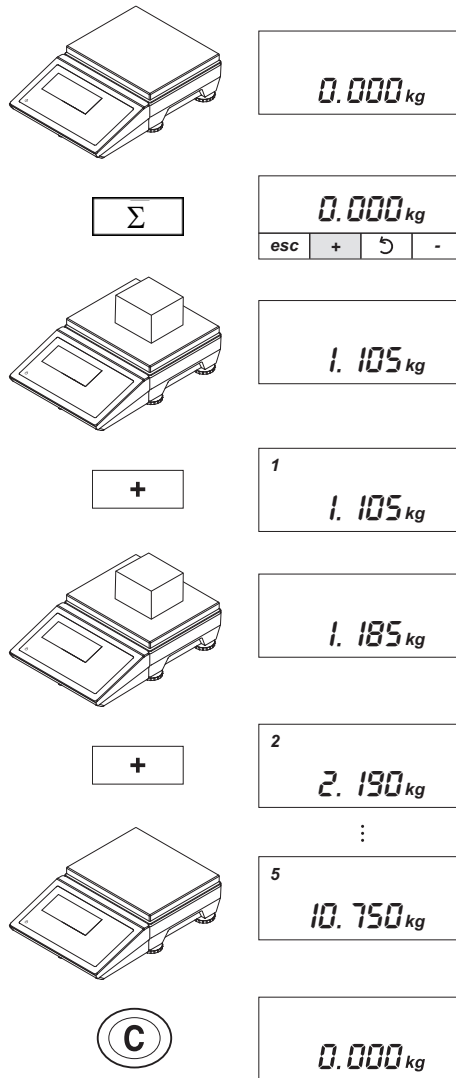

Les touches de fonction de totalisation sont affichées.

1^{er} élément totalisé.

Décharger la balance et placer le 2^e élément.

2^e élément totalisé.

5 éléments totalisés et le dernier élément retiré.

Total effacé.

5 Maintenance

La maintenance du terminal de pesage se limite à un nettoyage régulier.

5.1 Nettoyage



AVERTISSEMENT

Danger d'explosion

- 1 Observez strictement les instructions de la société d'exploitation.
- 2 Evitez les décharges électrostatiques en portant des vêtements de travail appropriés lorsque vous travaillez dans des zones dangereuses.

Notes sur le nettoyage

- Utilisez uniquement un chiffon propre humidifié et essuyez doucement le clavier.
- Utilisez de l'eau ou des produits de nettoyage doux, non abrasifs.
- Ne pulvérisez pas le produit de nettoyage directement sur le terminal de pesage.
- N'utilisez pas d'acides, d'alcalis ni de solvants forts.
- Ne nettoyez pas le terminal de pesage à l'aide d'eau sous haute pression ou à température élevée.
- Respectez toutes les réglementations existantes concernant les intervalles de nettoyage et les détergents autorisés.
- N'utilisez pas d'air comprimé ni de dépression.
- Enlevez les couches de poussière.

5.2 Mise au rebut

En conformité avec les exigences de la directive européenne 2002/96/CE sur les déchets d'équipements électriques et électroniques (DEEE), cet appareil ne peut pas être éliminé avec les ordures domestiques. Ceci s'applique également aux pays extérieurs à l'UE selon leurs exigences nationales spécifiques.

- Veuillez éliminer cet appareil en conformité avec la réglementation locale via les points de collecte séparés pour les équipements électriques et électroniques.



Si vous avez des questions, veuillez contacter les autorités responsables ou le distributeur chez qui vous avez acheté cet appareil.

En cas de transmission de cet appareil (par exemple pour une autre utilisation privée ou commerciale/industrielle), cette réglementation doit également être transmise.

Nous vous remercions pour votre contribution à la protection de l'environnement.

6 Caractéristiques techniques

Terminaux de pesage		ICS426x	ICS466x
Boîtier		Acier inoxydable	
Afficheur		Afficheur graphique LCD mono-chrome Rétroéclairage	Afficheur graphique LCD mono-chrome Rétroéclairage en couleur
Clavier		Clavier à membrane à point de poussée (PET), étiquetage résistant aux rayures	
Poids net		2,8 kg / 6,1 lb	
Degré de protection		IP65	
Connexion secteur		via APS768x	
Conditions ambiantes	Application	A utiliser en intérieur uniquement	
	Plage de température classe III	-10 °C ... 40 °C / 14 °F ... 104 °F	
	Humidité	Max. 85 % d'humidité rel. pour des température jusqu'à 40 °C / 104 °F	
Type de protection antidéflagrante	EN/IECEX	II 2G Ex ib IIC T4 Gb, -10 °C ... +40 °C II 2D Ex ib IIIC T60°C Db IP65	
	cFM _{US}	IS Classe I, II, III; Division 1 Groupe A, B, C, D, E, F, G; T4; Ta = 40 °C Aex ib IIC T4; IP65; Type 4	
Homologations P & M		OIML classes II, III, IIII NTEP classes II, III	
Interfaces		1 interface RS232-IS et 1 interface de balance intégrées 1 interface de communication supplémentaire en option	1 interface RS232-IS et 1 interface de balance intégrées 1 interface de communication supplémentaire en option 1 interface de balance supplémentaire en option
Applications		Pesage direct Détermination du poids moyen Impression intelligente	Pesage direct Détermination du poids moyen Impression intelligente Pesée de contrôle Plus/Moins Comptage Totalisation Base de données Interrogation Mémoire alibi

Interface de balance analogique (ICS466x uniquement)	
Impédance	80 ... 3.000 ohms
Excitation	3,3 V
Sensibilité	jusqu'à 3 mV/V
Résolution max.	10.000 e (OIML) 300.000 d (non homologable)
Intervalle de vérification min.	0,26 μ V/e

Plan coté série ICS4_6x

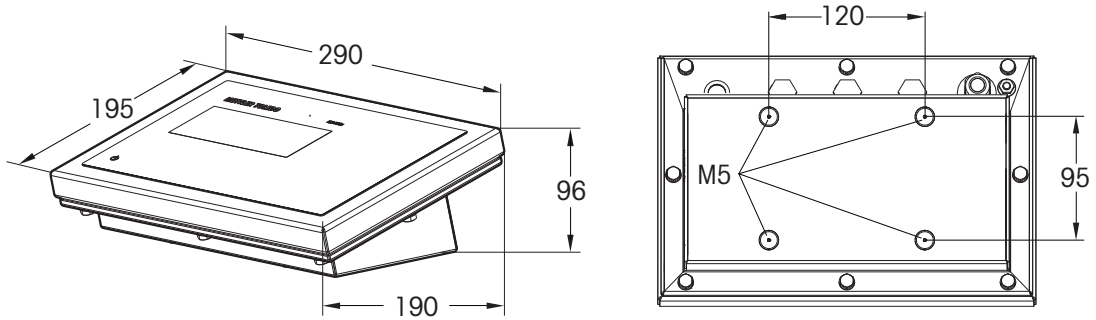

METTLER TOLEDO Service

Enhorabuena por elegir la calidad y precisión de METTLER TOLEDO. El uso adecuado de su nuevo equipo siguiendo este manual, y la calibración y mantenimiento regulares por parte del equipo de servicio formado en fábrica garantizan un funcionamiento fiable y preciso, protegiendo su inversión. Póngase en contacto con nosotros acerca del acuerdo de servicio ajustado a sus necesidades y presupuesto. Hay más información disponible en

www.mt.com/service

Existen varias maneras importantes de garantizar que usted maximizará el rendimiento de su inversión:

- 1 **Registre su producto:** Le invitamos a registrar su producto en www.mt.com/productregistration para que podamos ponernos en contacto con usted si hubiera mejoras, actualizaciones y notificaciones importantes relacionadas con su producto.
- 2 **Póngase en contacto con METTLER TOLEDO para obtener servicio:** Póngase en contacto con METTLER TOLEDO para obtener servicio: El valor de una medida es proporcional a su precisión: una báscula fuera de las especificaciones puede disminuir la calidad, reducir las ganancias y aumentar la responsabilidad. El servicio oportuno por parte de METTLER TOLEDO garantizará precisión y optimizará el tiempo de funcionamiento y la vida útil del equipo.
 - ⇒ **Instalación, configuración, integración y formación:** Nuestros representantes de servicio reciben una capacitación en fábrica y son expertos en equipos de pesaje. Nos aseguramos de que el equipo de pesaje esté listo para la producción de manera rentable y oportuna y de que el personal esté formado para obtener resultados exitosos.
 - ⇒ **Documentación de calibración inicial:** Los requisitos de aplicación y del entorno de instalación son únicos para cada báscula industrial. Su rendimiento se debe comprobar y certificar. Nuestros servicios y certificados de calibración documentan la precisión para garantizar la calidad en la producción y para proporcionar un registro de rendimiento del sistema de calidad.
 - ⇒ **Mantenimiento periódico de calibración:** El acuerdo de servicio de calibración proporciona confianza en el proceso de pesaje y documentación de cumplimiento de los requisitos. Ofrecemos diversos planes de servicio que se programan para satisfacer sus necesidades y están diseñados para ajustarse a su presupuesto.

Índice de contenidos

1	Instrucciones de seguridad	3
1.1	Uso previsto	3
1.2	Mal uso	3
1.3	Precauciones de seguridad para el uso en zonas peligrosas	3
2	Introducción	4
2.1	Terminales de pesada de las series ICS4_6x	4
2.2	Sobre este documento	4
2.3	Otros documentos.....	4
3	Instalación	5
3.1	Instalación, configuración, servicio y reparación	5
3.2	Nivelación.....	5
4	Manejo	6
4.1	Indicador	6
4.2	Teclado	8
4.3	Activar/Desactivar	9
4.4	Puesta a cero	9
4.5	Pesada lineal	9
4.6	Tarar	10
4.7	Imprimir o transferir datos.....	10
4.8	Conmutar unidad de medida.....	10
4.9	Recuento (solamente ICS466x).....	11
4.10	Encima/Debajo del control de peso (solamente ICS466x)	12
4.11	Totalidad (solamente ICS466x).....	13
5	Mantenimiento	14
5.1	Limpieza.....	14
5.2	Eliminación.....	14
6	Datos técnicos	15

1 Instrucciones de seguridad

1.1 Uso previsto

Los terminales de pesada de las series ICS4_6x son parte de un sistema de pesada modular a prueba de explosión que consiste en un terminal de pesada METTLER TOLEDO como indicador y al menos una plataforma de pesada.

Los terminales de pesada de las series ICS4_6x están aprobados para su operación en zonas peligrosas de la Categoría 2 / División 1.

- Utilizar el terminal de pesada solamente para pesar de acuerdo con esta Guía breve y el Manual de usuario correspondiente.
- El terminal de pesada se ha previsto sólo para uso en interiores.
- Cualquier otro tipo de uso se considera como no previsto.

Metrología legal

- Para el uso en metrología legal, utilizar únicamente sistemas de pesada aprobados.
- Al utilizar la metrología en forma legal, la empresa operadora es responsable de observar todos los pesos nacionales y los requisitos de las mediciones.
- Por favor, póngase en contacto con la organización de servicio METTLER TOLEDO para preguntas relacionadas con el uso legal para aplicaciones comerciales.

1.2 Mal uso

- No utilizar el terminal de pesada para otros fines que no sean operaciones de pesada.
- No modificar el terminal de pesada.
- No utilizar el terminal de pesada más allá de los límites de las especificaciones técnicas.

1.3 Precauciones de seguridad para el uso en zonas peligrosas

Los terminales de pesada de las series ICS4_6x están aprobados para su operación en zonas peligrosas de la Categoría 2 / División 1.

La empresa operadora es responsable del funcionamiento seguro del sistema de pesada protegido contra explosiones.



PELIGRO

Riesgo de explosión

- 1 Observar estrictamente las instrucciones de la empresa operadora.
- 2 Cumplir con todos los reglamentos nacionales para el uso en zonas peligrosas, así como las instrucciones y la información en esta Guía breve.

2 Introducción

2.1 Terminales de pesada de las series ICS4_6x

Esta Guía breve se centra en los siguientes terminales de pesada:

Tipo	Teclado numérico	Teclas programables	Entorno	Combinación de terminal y plataforma
ICS426x	–	–	Categoría 2 / División 1	con series PBK9/PFK-9 con opción de la Categoría 2 / División 1
ICS466x	x	x		opcional, p.ej. con series PBK9/PFK-9 con opción de la Categoría 2 / División 1 ó PBA430x

Interfaces de balanza

Los terminales de pesada de las series ICS4_6x están disponibles con varios interfaces de balanza. El interface de balanza incorporado se indica directamente después del tipo de terminal.

ICS4_6xa	...d
Interface de balanza	analógica (solamente ICS466x)	IDNet / SICSpro

2.2 Sobre este documento



Este documento contiene toda la información para el **operador** de los terminales de pesada de las series ICS4_6x.

- Leer atentamente este documento antes de proceder al manejo.
- Guardar este documento para futura referencia.
- Entregar este documento a cualquier futuro propietario o usuario del producto.

2.3 Otros documentos

En complemento a este documento impreso puede descargar los siguientes documentos de <http://www.mt.com>:

- Manuales del operador
- Manuales técnicos
- Manuales de instalación
- Hojas de datos
- Vídeos
- Folletos
- Documentos de aprobación del tipo
- Para combinaciones de terminal y plataforma: Manuales de usuario de las plataformas de pesada conectadas

Documentos de aprobación del tipo

ICS4_6x	Categoría 2	BVS 13 ATEX E042X IECEX BVS 13.0050X
	Division 1	FM16US00098

3 Instalación

3.1 Instalación, configuración, servicio y reparación

- Para la instalación, configuración, mantenimiento y reparación del sistema de pesada a prueba de explosión llamar al servicio METTLER TOLEDO.

3.2 Nivelación

Los terminales de pesada ICS4_6x están disponibles como combinación de terminal y plataforma.

Solamente las plataformas de pesada que han sido niveladas exactamente horizontal proporcionan resultados exactos en las pesadas. Los pesos y medidas de plataformas de pesada aprobadas tienen un nivel de burbuja para simplificar el nivelado.

- Girar los pies de nivelación de la plataforma de pesada, hasta que la burbuja de aire del nivel de burbuja esté dentro del círculo interior.

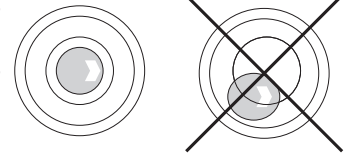

4 Manejo

4.1 Indicador

4.1.1 Composición estándar

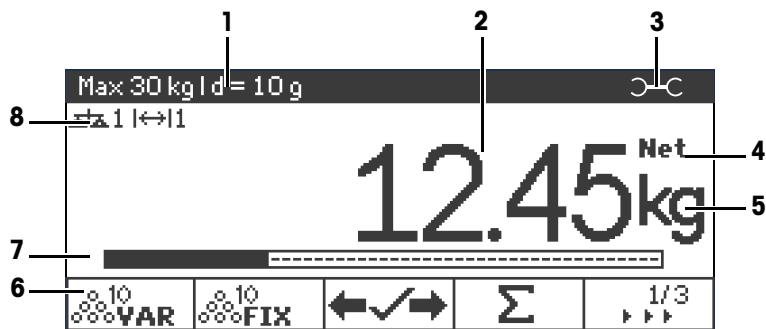

- 1 Línea de datos metrológicos
- 2 Valor de pesada
- 3 Icono llave de tuercas: servicio necesario
- 4 Neto/Bruto
- 5 Unidad
- 6 Teclas programables (ajuste de fábrica, página 1, solamente ICS466x)
- 7 Línea auxiliar de datos: El contenido se define en el menú, ver Manual de usuario.
- 8 Símbolos y línea info

Línea de datos metrológicos

i Los datos metrológicos se almacenan en la plataforma de pesada. El terminal de pesada sirve sólo como indicador.

En la línea de datos metrológicos se indica la siguiente información:

Símbolo	Información
	Clases de precisión
W1 , W2 , W3	Información del campo de pesada
Max , cap	Capacidad máxima
Min	Capacidad mínima
e =	Resolución aprobada
d =	Resolución del display
Approved scale	Dispositivo de pesada aprobado
-10 °C ... +40 °C	Rango de temperatura

4.1.2 Valor de pesada

El valor de pesada puede ser marcado con los siguientes símbolos:

Símbolo	Información
*	Valor de pesada calculado
—	Signo para valores negativos de pesada
○	Control de estabilización para valores inestables de pesada
1.234₃ kg	Último dígito no aprobado con e > d







4.1.3 Línea símbolos y info

En la línea símbolos y info debe indicarse la siguiente información. Para más símbolos, consultar el Manual de usuario.

Símbolo	Información	Disponibilidad
	Número de balanza	No para ICS426x
<->	Gama de pesada	Sólo para balanzas multi rango o multi intervalo
	Peso por debajo del peso mínimo	
	Tarado automático	
	Borrado automático del peso de tara	
>0<	Indicación del centro de cero	En función de las directrices de pesos y medidas locales
Σ	Totalización	No para ICS426x
Fact	FACT necesita ser realizado	Aparece solamente si la función se apoya en la plataforma de pesada, p.ej. las series PBK9/PFK9







4.2 Teclado

4.2.1 Teclas de función

Tecla	Nombre	Tecla	Nombre
	Alimentación		Tara
	Borrar		Info
	Conmutar		Transferir
	Cero		

4.2.2 Teclas programables principales (solamente ICS466x)

Para cumplir con sus requisitos de aplicación específicos, los terminales de pesada ICS466x ofrecen teclas programables que se pueden configurar en el menú. Para más teclas programables, consultar el Manual de usuario.

ICS4_6x	Menú ajuste	Función
	Ref N var	Determinar el peso unitario medio, libremente ajustable
	Ref N fija	Determinar el peso unitario medio, tamaños fijos de referencia
	Peso/Recuento	Conmutar entre display de peso y display de piezas
	Totalidad	Iniciar la totalidad
	Encima/Debajo del control de peso	Entrar parámetros por Encima/Debajo del control de peso
	Guardar artículo	Guardar los parámetros del artículo actual en la base de datos
	Recordar artículo	Recordar parámetros de la base de datos

4.3 Activar/Desactivar

Conexión

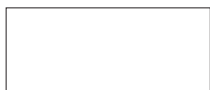
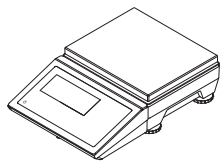

Desconexión

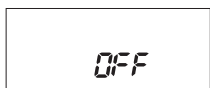
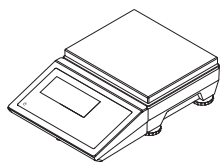

Pulsar prolongado  hasta que aparece **OFF**.

4.4 Puesta a cero

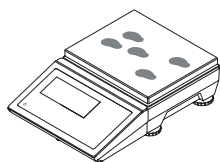

La función puesta a cero corrige la influencia de ligeros ensuciamientos sobre el plato de carga o de pequeñas discrepancias de la puesta a cero.

4.5 Pesada lineal

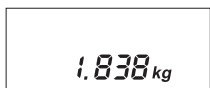
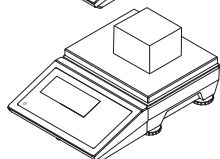
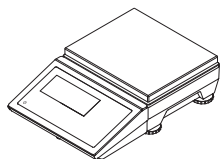

4.6 Tarar

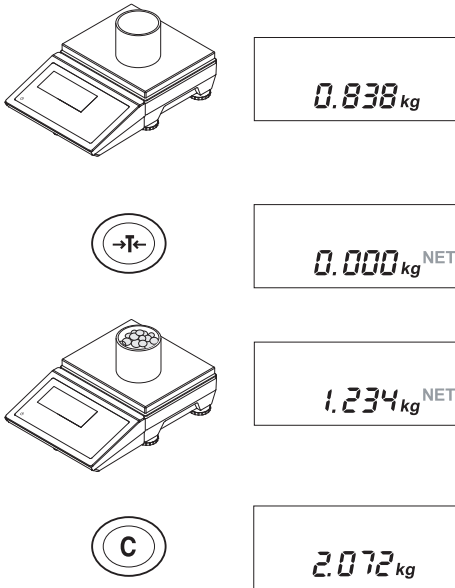

Una vez que la balanza está tarada, aparece el símbolo NET.

Cuando la tara es borrada, aparece el peso bruto.

4.7 Imprimir o transferir datos

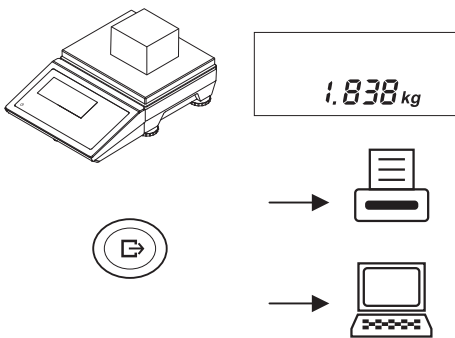

- La impresora o el ordenador tiene que estar situado en el sector de seguridad.
- Los datos tienen que ser transferidos al sector de seguridad a través del convertidor de interface ACM200.

4.8 Conmutar unidad de medida

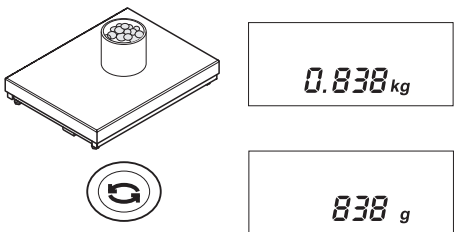

4.9 Recuento (solamente ICS466x)

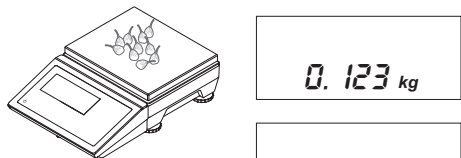
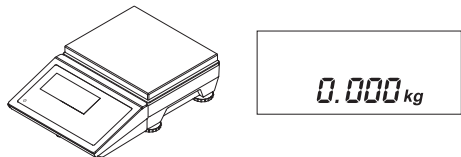

 **VAR**

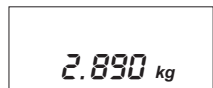
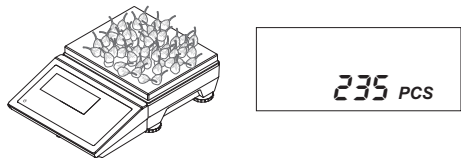

Borrar recuento

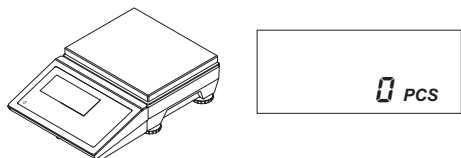

Emplear el número de piezas de referencia indicado en la tecla programable, en este ejemplo: 10 piezas.

Conmutar entre el display del número de piezas y el peso.

Pulsar la tecla **C** para borrar los parámetros de recuento. En el display aparece el peso.

4.10 Encima/Debajo del control de peso (solamente ICS466x)

Configurar valores teóricos

	<table border="1"> <tr><td>Tol. type:</td><td>Absoluto</td></tr> <tr><td>Baja:</td><td>0.00 kg</td></tr> <tr><td>Alta:</td><td>0.00 kg</td></tr> </table>	Tol. type:	Absoluto	Baja:	0.00 kg	Alta:	0.00 kg
Tol. type:	Absoluto						
Baja:	0.00 kg						
Alta:	0.00 kg						
	<table border="1"> <tr><td>Tol. type:</td><td>Absoluto</td></tr> <tr><td>Baja:</td><td>0.00 kg</td></tr> <tr><td>Alta:</td><td>0.00 kg</td></tr> </table>	Tol. type:	Absoluto	Baja:	0.00 kg	Alta:	0.00 kg
Tol. type:	Absoluto						
Baja:	0.00 kg						
Alta:	0.00 kg						
	<table border="1"> <tr><td>Tol. type:</td><td>Absoluto</td></tr> <tr><td>Baja:</td><td>9.5 kg</td></tr> <tr><td>Alta:</td><td>0.00 kg</td></tr> </table>	Tol. type:	Absoluto	Baja:	9.5 kg	Alta:	0.00 kg
Tol. type:	Absoluto						
Baja:	9.5 kg						
Alta:	0.00 kg						
	<table border="1"> <tr><td>Tol. type:</td><td>Absoluto</td></tr> <tr><td>Baja:</td><td>9.5 kg</td></tr> <tr><td>Alta:</td><td>0.00 kg</td></tr> </table>	Tol. type:	Absoluto	Baja:	9.5 kg	Alta:	0.00 kg
Tol. type:	Absoluto						
Baja:	9.5 kg						
Alta:	0.00 kg						
	<table border="1"> <tr><td>Tol. type:</td><td>Absoluto</td></tr> <tr><td>Baja:</td><td>9.50 kg</td></tr> <tr><td>Alta:</td><td>10.4 kg</td></tr> </table>	Tol. type:	Absoluto	Baja:	9.50 kg	Alta:	10.4 kg
Tol. type:	Absoluto						
Baja:	9.50 kg						
Alta:	10.4 kg						
	<table border="1"> <tr><td colspan="2">¡Nuevo val. final asign.!</td></tr> </table>	¡Nuevo val. final asign.!					
¡Nuevo val. final asign.!							
<table border="1" style="width: 100%;"> <tr><td style="text-align: center;">LW: 9.50kg</td><td style="text-align: center;">HI: 10.40kg</td></tr> </table>		LW: 9.50kg	HI: 10.40kg				
LW: 9.50kg	HI: 10.40kg						

Para otros tipos de tolerancia, consultar el Manual de usuario.

Usted puede pesar el peso teórico o introducirlo numéricamente.

Display Encima/Debajo del control de peso



Peso dentro de las tolerancias

Peso por encima de las tolerancias

Peso por debajo de las tolerancias

Terminar Encima/Debajo del control de peso

- ESC** Salir de Encima/Debajo del control de peso, pero mantener los valores teóricos.
- C** Salir de Encima/Debajo del control de peso y borrar los valores teóricos.

4.11 Totalidad (solamente ICS466x)

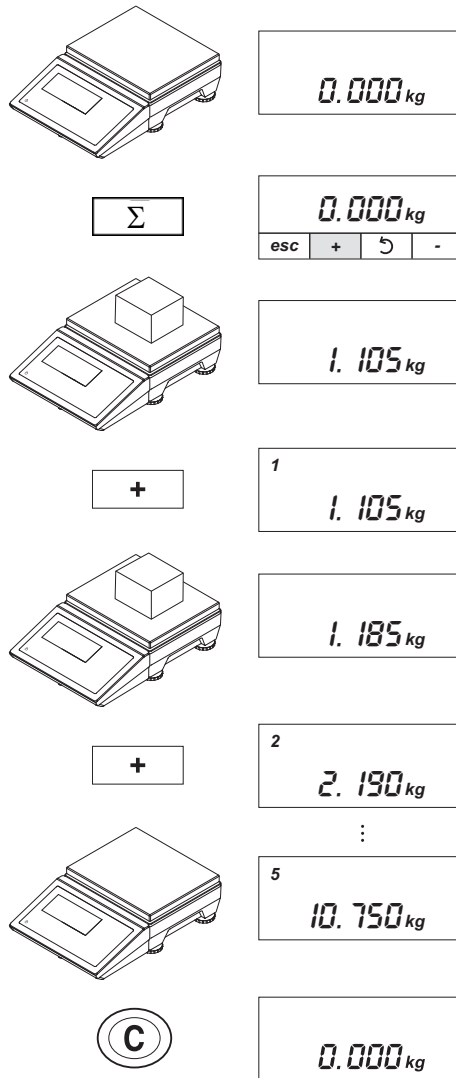

Se muestra la totalidad de las teclas programables.

1^{er} artículo totalizado.

Descargar la balanza y colocar el 2^o artículo.

2^o artículo totalizado.

5 artículos totalizados y el último artículo tachado.

Total borrado.

5 Mantenimiento

El mantenimiento del terminal de pesada se limita a la limpieza regular.

5.1 Limpieza



ADVERTENCIA

Riesgo de explosión

- 1 Observar estrictamente las instrucciones de la empresa operadora.
- 2 Evitar la carga electrostática llevando puesta ropa de trabajo adecuada durante el manejo en sectores peligrosos.

Notas sobre la limpieza

- Utilizar únicamente un paño húmedo limpio y limpiar con cuidado el teclado.
- Utilizar agua o agentes de limpieza suaves y no abrasivos.
- No pulverizar limpiador directamente en el terminal de pesada.
- No utilizar ácidos, lejías o solventes fuertes.
- No limpiar el terminal de pesada utilizando agua a alta presión y alta temperatura.
- Observar todas las prescripciones vigentes sobre los intervalos de limpieza y los agentes de limpieza admitidos.
- No utilizar aire comprimido ni vacío.
- Eliminar las capas polvorientas.

5.2 Eliminación

De conformidad con las exigencias de la directiva europea 2002/96 CE sobre residuos de dispositivos eléctricos y electrónicos (RAEE), este dispositivo no debe eliminarse como basura doméstica. Esto también se aplica a los países fuera de la UE, de conformidad con sus respectivas disposiciones nacionales.

- Rogamos desechar este producto de conformidad con sus disposiciones locales sobre la recogida selectiva de equipos eléctricos y electrónicos de desecho.



Si tiene alguna pregunta, por favor póngase en contacto con las autoridades correspondientes o con el distribuidor donde compró este dispositivo.

Si se transfiere este dispositivo a terceros (por ejemplo para otro uso privado o comercial/industrial), esta disposición debe también ser transferida.

Muchas gracias por su contribución a la protección del medio ambiente.

6 Datos técnicos

Terminales de pesada		ICS426x	ICS466x
Carcasa		Acero inoxidable	
Display		Display gráfico LCD monocromo Retroiluminación	Display gráfico LCD monocromo Retroiluminación de color
Teclado		Teclado laminar con punto de presión (PET), etiquetado resistente al rasgado	
Peso neto		2,8 kg / 6,1 lb	
Clase de protección		IP65	
Conexión a la red		a través de APS768x	
Condiciones ambientales	Aplicación	sólo uso en interiores	
	Margen de temperatura Clase III	-10 °C ... 40 °C / 14 °F ... 104 °F	
	Humedad del aire	Máx. humedad rel. del aire 85 %, para temperaturas hasta 40 °C / 104 °F	
Clase de protección de ignición	EN/IECEX	II 2G Ex ib IIC T4 Gb, -10 °C ... +40 °C II 2D Ex ib IIIC T60°C Db IP65	
	cFM _{US}	IS Clase I, II, III; División 1; Grupo A, B, C, D, E, F, G; T4; Ta = 40 °C AEx ib IIC T4; IP65; Tipo 4	
Aprobación P & M		OIML Clase II, III, IIII NTEP Clase II, III	
Interfaces		1 interface RS232 y 1 interface de balanza integrado 1 interface de comunicación opcional adicional	1 interface RS232 y 1 interface de balanza integrado 1 interface de comunicación opcional adicional 1 interface de balanza opcional adicional
Aplicaciones		Pesada lineal Pesada promedio Impresión inteligente	Pesada lineal Pesada promedio Impresión inteligente Encima/Debajo del control de peso Recuento Totalidad Base de datos Presentar mensaje Memoria Alibi

Interface de balanza analógica (solamente ICS466x)	
Impedancia	80 ... 3.000 ohmios
Excitación	3,3 V
Sensibilidad	hasta 3 mV/V
Máx. resolución	10.000 e (OIML) 300.000 d (no aprobable)
Mín. intervalo de contrastado	0,26 μ V/e

Plano de medidas de las series ICS4_6x

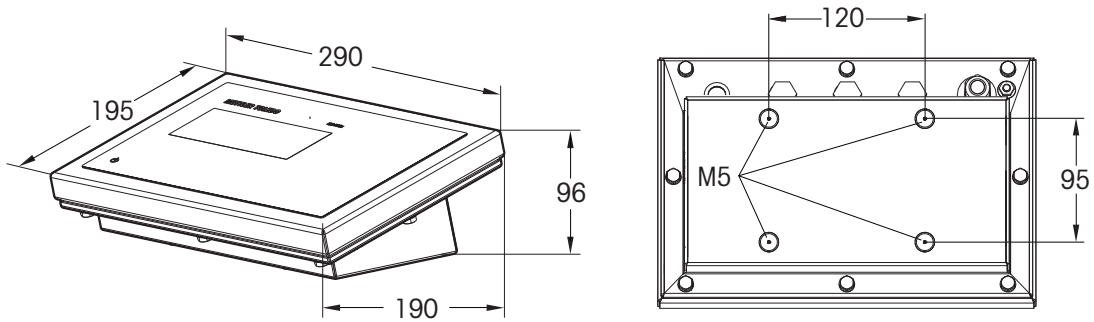

METTLER TOLEDO Service

Grazie per aver scelto la qualità e la precisione di METTLER TOLEDO. Utilizzando questo nuovo dispositivo in modo appropriato, nel rispetto delle istruzioni del manuale e della regolazione e della manutenzione regolare offerti dal nostro team di assistenza addestrato in fabbrica, il funzionamento rimarrà affidabile e preciso, proteggendo l'investimento. Non esiti a contattarci per un contratto di servizio personalizzato per le sue esigenze e il suo budget. Ulteriori informazioni sono reperibili sul sito Web

www.mt.com/service

I metodi che consentono di massimizzare le prestazioni dell'investimento sono svariati:

- 1 **Registri il prodotto:** la invitiamo a registrare il prodotto sul sito www.mt.com/productregistration e sarà contattato in caso di miglioramenti, aggiornamenti e notifiche importanti.
- 2 **Per assistenza contatti METTLER TOLEDO:** il valore della misurazione è proporzionale alla sua precisione – una bilancia non regolata può diminuire la qualità, ridurre i profitti e aumentare la responsabilità Assistenza tempestiva da parte di METTLER TOLEDO garantisce precisione, ottimizzano il funzionamento e la durata del dispositivo.
 - ⇒ **Installazione, configurazione, integrazione e addestramento:** I nostri addetti all'assistenza sono esperti addestrati in fabbrica sui dispositivi di pesatura. Ci accertiamo che il dispositivo di pesatura sia pronto per la produzione, tempestivamente e in modo conveniente e che il personale sia opportunamente addestrato.
 - ⇒ **Documentazione della regolazione iniziale:** I requisiti ambientali e applicativi di installazione sono unici per ogni bilancia industriale e le prestazioni devono essere testate e certificate. I nostri servizi di calibrazione e l'accuratezza dei documenti certificati garantiscono la qualità di produzione e un sistema di qualità con record delle prestazioni.
 - ⇒ **Manutenzione periodica di regolazione:** Il contratto del Servizio di regolazione offre una garanzia costante nel processo di pesatura e la documentazione di conformità ai requisiti. Offriamo una serie di piani di assistenza programmati per soddisfare le esigenze e determinati in base al budget.

Sommario

1	Istruzioni di sicurezza	3
1.1	Usò previsto	3
1.2	Utilizzo improprio.....	3
1.3	Osservazioni sulla sicurezza in caso di utilizzo in aree pericolose	3
2	Introduzione	4
2.1	Terminali di pesata della serie ICS4_6x	4
2.2	Informazioni sul presente documento	4
2.3	Altri documenti	4
3	Installazione	5
3.1	Installazione, configurazione, manutenzione e riparazione	5
3.2	Messa in bolla.....	5
4	Funzionamento	6
4.1	Unità di indicazione	6
4.2	Tastiera	8
4.3	Accensione / spegnimento	9
4.4	Azzeramento	9
4.5	Pesata lineare	9
4.6	Detrazione della tara	10
4.7	Stampa o trasferimento dati	10
4.8	Commutazione unità di peso.....	10
4.9	Conteggio (solo ICS466x)	11
4.10	Pesata di controllo più/meno (solo ICS466x).....	12
4.11	Totalizzazione (solo ICS466x)	13
5	Manutenzione	14
5.1	Pulizia.....	14
5.2	Smaltimento.....	14
6	Caratteristiche tecniche	15

1 Istruzioni di sicurezza

1.1 Uso previsto

I terminali di pesata della serie ICS4_6x fanno parte di un sistema di pesata modulare con protezione anti-deflagrante consistente di un terminale di pesata METTLER TOLEDO come unità di indicazione e almeno una piattaforma di pesata.

I terminali di pesata della serie ICS4_6x sono approvati per il funzionamento in aree pericolose della Categoria 2 / Divisione 1.

- Utilizzare il terminale di pesata unicamente per operazioni di pesata in accordo con la presente Guida Rapida e con le Istruzioni d'uso corrispondenti.
- Il terminale di pesata è previsto unicamente per l'uso in ambienti al chiuso.
- Qualsiasi altro tipo di utilizzo è da considerarsi non conforme.

Metrologia legale

- Per l'uso in metrologia, legale utilizzare esclusivamente sistemi di pesata approvati.
- Quando i terminali di pesata vengono utilizzati in metrologia legale, l'esercente è responsabile del rispetto di tutti i requisiti nazionali in vigore in materia di pesi e misure.
- Per domande sull'uso in applicazioni legali per il commercio, vogliate contattare il Servizio Assistenza Tecnica METTLER TOLEDO.

1.2 Utilizzo improprio

- Non utilizzare il terminale di pesata per operazioni diverse dalla pesata.
- Non modificare il terminale di pesata.
- Non utilizzare il terminale di pesata oltre i limiti indicati nelle specifiche tecniche.

1.3 Osservazioni sulla sicurezza in caso di utilizzo in aree pericolose

I terminali di pesata della serie ICS4_6x sono approvati per il funzionamento in aree pericolose della Categoria 1 / Divisione 1.

L'esercente ha la responsabilità di garantire un funzionamento sicuro del sistema di pesata protetto contro le esplosioni.



PERICOLO

Rischio di esplosione

- 1 Attenersi scrupolosamente alle istruzioni dell'esercente.
- 2 Rispettare le norme nazionali per il funzionamento in aree pericolose, così come le istruzioni e le informazioni contenute nella presente Guida rapida.

2 Introduzione

2.1 Terminali di pesata della serie ICS4_6x

La presente Guida Rapida riguarda i terminali di pesata elencati sotto:

Modello	Tastiera numerica	Tasti funzione	Ambiente	Combinazione di terminale e piattaforma
ICS426x	–	–	Categoria 2 / Divisione 1	con serie PBK9-/PFK-9 con option Categoria 2 / Divisione 1
ICS466x	x	x		opzionale, ad esempio, con serie PBK9-/PFK-9 con option Categoria 2 / Divisione 1 o PBA430x

Interfacce bilancia

I terminali di pesata della serie ICS4_6x sono disponibili con varie interfacce bilancia. Il tipo di interfaccia bilancia incorporata è indicato direttamente dopo il modello del terminale.

ICS4_6xa	...d
Interfaccia bilancia	analogica (solo ICS466x)	IDNet / SICSpr

2.2 Informazioni sul presente documento



Questo documento contiene tutte le informazioni per **l'operatore** dei terminali di pesata della serie ICS4_6x.

- Leggere attentamente questo documento prima dell'uso.
- Conservare questo documento per future consultazioni.
- Consegnare questo documento agli eventuali futuri proprietari o utilizzatori dello strumento.

2.3 Altri documenti

Oltre a questo documento in formato cartaceo, è possibile scaricare i seguenti documenti da www.mt.com:

- Manuali per l'utente
- Manuali tecnici
- Manuali per l'installatore
- Fogli dati
- Video
- Opuscoli
- Documenti di approvazione modello
- Combinazioni di terminale e piattaforma: Istruzioni d'uso delle piattaforme di pesata collegate

Documenti di approvazione modello

ICS4_6x	Categoria 2	BVS 13 ATEX E042X IECEX BVS 13.0050X
	Division 1	FM16US00098

3 Installazione

3.1 Installazione, configurazione, manutenzione e riparazione

- Per interventi di installazione, configurazione, manutenzione e riparazione di un sistema di pesata con protezione antideflagrante contattare il Servizio Assistenza Tecnica METTLER TOLEDO.

3.2 Messa in bolla

I terminali di pesata ICS4_6x sono disponibili come combinazione di terminale e piattaforma.

Solo le piattaforme di pesata che sono state messe in bolla con precisione forniscono risultati di pesata accurati. Le piattaforme di pesata approvate dall'Ufficio Pesi e Misure sono munite di una livella a bolla per semplificare la messa in bolla.

- Ruotare i piedini regolabili della piattaforma di pesata fino a che la bolla d'aria della livella si posiziona nel cerchio interno.

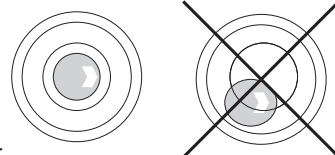

4 Funzionamento

4.1 Unità di indicazione

4.1.1 Layout di default

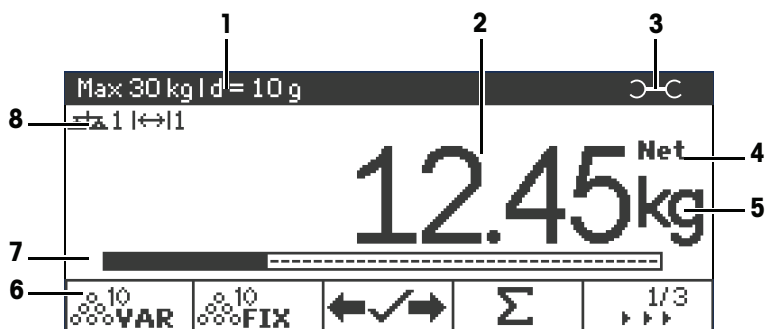

- 1 Riga dati metrologici
- 2 Valore di peso
- 3 Icona chiave inglese: necessario intervento di manutenzione
- 4 Netto/lordo
- 5 Unità
- 6 Tasti funzione (preimpostazione di fabbrica, pagina 1, solo ICS466x)
- 7 Barra dati ausiliari: Il contenuto è definito nel menu, consultare le Istruzioni d'Uso.
- 8 Barra simboli e info

Riga dati metrologici



i I dati metrologici vengono memorizzati nella piattaforma di pesata. Il terminale di pesata serve soltanto come indicatore.

Nella barra dei dati metrologici vengono visualizzate le seguenti informazioni:

Simbolo	Informazioni
	Classi di precisione
W1 , W2 , W3	Informazioni sul campo di pesata
Max , cap	Portata massima
Min	Portata minima
e =	Risoluzione approvata
d =	Risoluzione di indicazione
Approved scale	Strumento di pesata omologato
-10 °C ... +40 °C	Intervallo di temperatura





4.1.2 Valore di peso

Il valore di peso può essere contrassegnato con i seguenti simboli:

Simbolo	Informazioni
	Valore di peso calcolato
	Per valori di peso negativi
	Monitor di stabilità per valori di peso instabili
1.234₃ kg	Ultima cifra non approvata con e > d

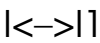





4.1.3 Barra simboli e info

Nella barra dei simboli e delle info possono essere visualizzate le seguenti informazioni. Per più simboli, consultare le Istruzioni d'Uso.

Simbolo	Informazioni	Disponibilità
	Numero bilancia	Non per ICS426x
	Intervallo di pesata	Solo per bilance multirange o bilance a campi multipli
	Peso inferiore al peso minimo	
	Detrazione automatica tara	
	Cancellazione automatica del peso di tara	
>0<	Indicazione centro di zero	A seconda delle prescrizioni dell'Ufficio Pesì e Misure locale
Σ	Totalizzazione	Non per ICS426x
Fact	È necessario effettuare un Fact	Questo messaggio viene visualizzato solo se la funzione è supportata dalla piattaforma di pesata, ad esempio, serie PBK9-/PFK9







4.2 Tastiera

4.2.1 Tasti funzione

Tasto	Nome	Tasto	Nome
	On/Off		Tara
	Cancela		Info
	Commutazione		Trasferisce
	Zero		

4.2.2 Tasti funzione principali (solo ICS466x)

Per soddisfare requisiti di applicazioni specifiche, i terminali di pesata ICS466x hanno tasti funzione configurabili nel menu. Per più tasti funzione, consultare le Istruzioni d'Uso.

ICS4_6x	Opzione di menu	Funzione
	Ref n var	Determinazione peso medio pezzi, regolabile liberamente
	Ref n fix	Determinazione del peso medio, quantità di riferimento fisse
	Peso/conteggio	Commutazione tra indicazione del peso e indicazione dei pezzi
	Totalizzazione	Avvio totalizzazione
	Pesata di controllo più/meno	Immissione parametri Pesata di controllo più/meno
	Salva articolo	Salvataggio dei parametri dell'articolo corrente nel database
	Richiama articolo	Richiamo di parametri dal database

4.3 Accensione / spegnimento

Accensione

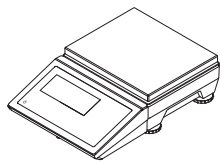

Spegnimento

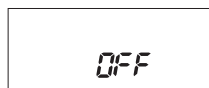
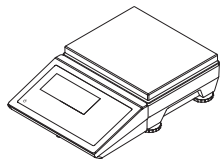

Tenere premuto  fino a che viene visualizzato **OFF**.

4.4 Azzeramento

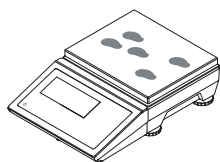

La funzione di azzeramento corregge l'influenza di piccole variazioni sul piatto di carico o piccole deviazioni dal punto zero.

4.5 Pesata lineare

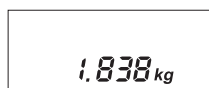
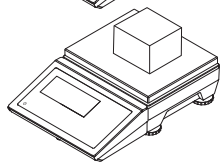
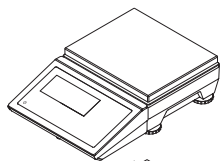

4.6 Detrazione della tara

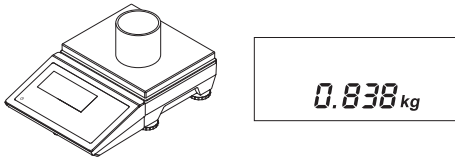

Quando la bilancia è tarata, nell'indicatore compare il simbolo NET.

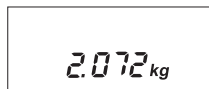
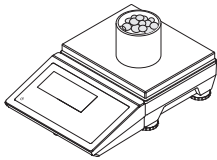

Quando la tara viene cancellata, l'indicatore visualizza il peso lordo.

4.7 Stampa o trasferimento dati

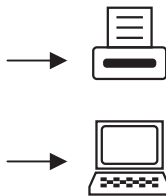
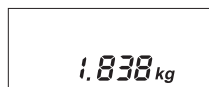
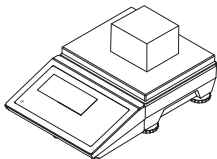

- La stampante o il computer devono essere posizionati nell'area sicura.
- I dati devono essere trasferiti all'area sicura tramite il convertitore d'interfaccia ACM200.

4.8 Commutazione unità di peso

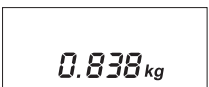
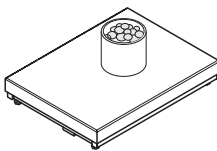

4.9 Conteggio (solo ICS466x)

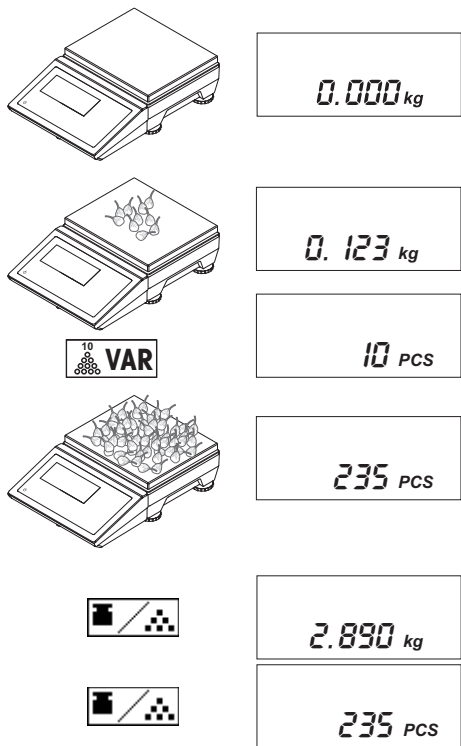

Cancellazione parametri di conteggio

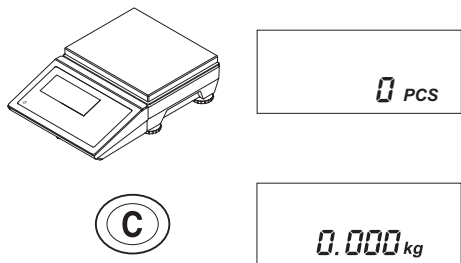







Usare il numero di parti di riferimento indicato sul tasto funzione, in questo esempio: 10 pezzi.

Commutare tra indicazione del numero di pezzi e del peso.

Premere il tasto **C** per cancellare i parametri di conteggio. L'unità di indicazione visualizza il peso.

4.10 Pesata di controllo più/meno (solo ICS466x)

Impostazione valori bersaglio

	<table border="1"> <tr><td>Tipo tol:</td><td>Assoluta</td></tr> <tr><td>Basso:</td><td>0.00 kg</td></tr> <tr><td>Alto:</td><td>0.00 kg</td></tr> </table>	Tipo tol:	Assoluta	Basso:	0.00 kg	Alto:	0.00 kg
Tipo tol:	Assoluta						
Basso:	0.00 kg						
Alto:	0.00 kg						
	<table border="1"> <tr><td>Tipo tol:</td><td>Assoluta</td></tr> <tr><td>Basso:</td><td>0.00 kg</td></tr> <tr><td>Alto:</td><td>0.00 kg</td></tr> </table>	Tipo tol:	Assoluta	Basso:	0.00 kg	Alto:	0.00 kg
Tipo tol:	Assoluta						
Basso:	0.00 kg						
Alto:	0.00 kg						
	<table border="1"> <tr><td>Tipo tol:</td><td>Assoluta</td></tr> <tr><td>Basso:</td><td>9.5 kg</td></tr> <tr><td>Alto:</td><td>0.00 kg</td></tr> </table>	Tipo tol:	Assoluta	Basso:	9.5 kg	Alto:	0.00 kg
Tipo tol:	Assoluta						
Basso:	9.5 kg						
Alto:	0.00 kg						
	<table border="1"> <tr><td>Tipo tol:</td><td>Assoluta</td></tr> <tr><td>Basso:</td><td>9.5 kg</td></tr> <tr><td>Alto:</td><td>0.00 kg</td></tr> </table>	Tipo tol:	Assoluta	Basso:	9.5 kg	Alto:	0.00 kg
Tipo tol:	Assoluta						
Basso:	9.5 kg						
Alto:	0.00 kg						
	<table border="1"> <tr><td>Tipo tol:</td><td>Assoluta</td></tr> <tr><td>Basso:</td><td>9.5 kg</td></tr> <tr><td>Alto:</td><td>10.4 kg</td></tr> </table>	Tipo tol:	Assoluta	Basso:	9.5 kg	Alto:	10.4 kg
Tipo tol:	Assoluta						
Basso:	9.5 kg						
Alto:	10.4 kg						
	<table border="1"> <tr><td colspan="2">Nuovo val. teorico impostato</td></tr> </table>	Nuovo val. teorico impostato					
Nuovo val. teorico impostato							

LW: 9.50kg
HI: 10.40kg

Per altri tipi di tolleranza, consultare le Istruzioni d'Uso.

Potete pesare il peso bersaglio oppure introdurlo numericamente.

Indicatore di pesata di controllo più/meno

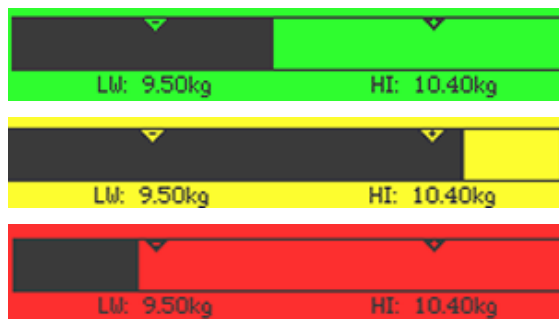

Peso entro i limiti di tolleranza

Peso al disopra dei limiti di tolleranza

Peso al disotto dei limiti di tolleranza

Uscita dalla modalità Pesata di controllo più/meno

- Esc** Uscita dalla funzione Pesata di controllo più/meno, conservando i valori bersaglio.
- C** Uscita dalla funzione Pesata di controllo più/meno e cancellazione dei valori bersaglio.

4.11 Totalizzazione (solo ICS466x)

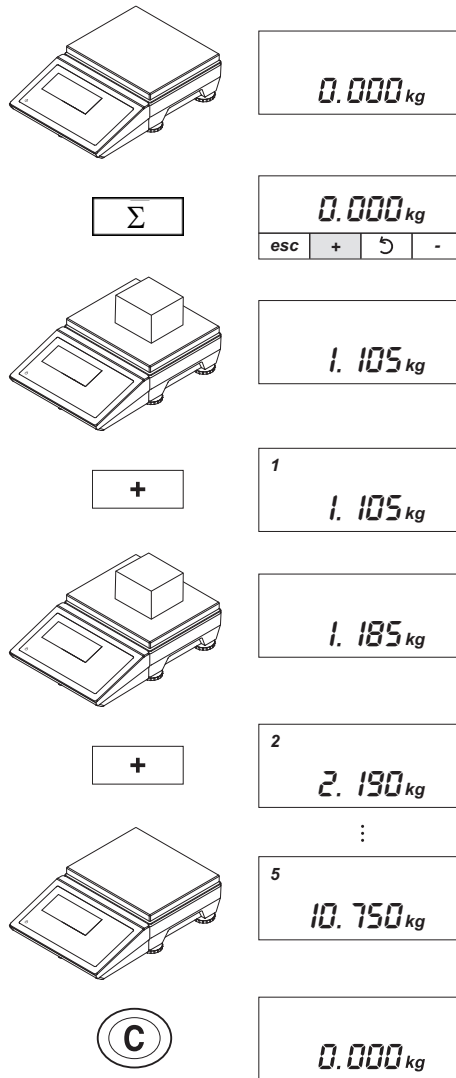

Vengono visualizzati i tasti funzione per la totalizzazione.

1° articolo totalizzato.

Scaricare la bilancia e collocare il 2° articolo.

2° articolo totalizzato.

5 articoli totalizzati e ultimo articolo rimosso.

Totale cancellato.

5 Manutenzione

La manutenzione del terminale di pesata è limitata alla pulizia regolare.

5.1 Pulizia



AVVERTENZA

Rischio di esplosione

- 1 Attenersi scrupolosamente alle istruzioni dell'esercente.
- 2 Evitare scariche elettrostatiche indossando abbigliamento da lavoro idoneo quando si lavora in aree pericolose.

Osservazioni relative alla pulizia

- Utilizzare esclusivamente un panno pulito umido e strofinare delicatamente la tastiera.
- Utilizzare acqua o agenti detergenti delicati, non abrasivi.
- Non spruzzare il detergente direttamente sul terminale di pesata.
- Non utilizzare acidi, prodotti alcalini né solventi forti.
- Non pulire il terminale di pesata con dispositivi di pulitura ad alta pressione né acqua a temperature elevate.
- Attenersi alle istruzioni circa gli intervalli di pulizia e utilizzare esclusivamente gli agenti detergenti ammessi.
- Non utilizzare aria compressa né vuoto.
- Rimuovere la polvere.

5.2 Smaltimento

In conformità con i requisiti imposti dalla Direttiva Europea 2002/96/CE in materia di smaltimento di rifiuti di apparecchiature elettriche ed elettroniche (RAEE), questa apparecchiatura non può essere smaltita come i normali rifiuti domestici. Questo vale anche per i Paesi al di fuori dell'UE in accordo con le rispettive norme nazionali.

- Si raccomanda di smaltire questo prodotto in accordo con le disposizioni locali riguardo i punti di raccolta differenziata per apparecchiature elettriche ed elettroniche.

Per qualsiasi domanda o dubbio, vogliate contattare le autorità competenti o il fornitore dal quale lo strumento è stato acquistato.

In caso di vendita di questo strumento (ad esempio per l'ulteriore utilizzo da parte di un privato o per uso commerciale/industriale), la presente norma continua a valere.

Vi ringraziamo per il vostro contributo alla salvaguardia dell'ambiente.



6 Caratteristiche tecniche

Terminali di pesata		ICS426x	ICS466x
Chassis		Acciaio inossidabile	
Unità di indicazione		Indicatore grafico LCD monocromatico Retroilluminazione	Indicatore grafico LCD monocromatico Retroilluminazione a colori
Tastiera		Tastiera a membrana a sfioramento (PET), etichettatura resistente ai graffi	
Peso netto		2,8 kg / 6,1 lb	
Tipo di protezione		IP65	
Collegamento alla rete di alimentazione		Tramite APS768x	
Condizioni ambiente	Applicazione	Solo per uso in ambienti al chiuso	
	Intervallo di temperatura Classe III	-10 °C ... 40 °C / 14 °F ... 104 °F	
	Umidità	Umidità massima relativa 85 % per temperature fino a 40 °C / 104 °F	
Tipo di protezione antideflagrante	EN/IECEx	II 2G Ex ib IIC T4 Gb, -10 °C ... + 40 °C II 2D Ex ib IIIC T60°C Db IP65	
	cFM _{US}	IS Classe I, II, III; Divisione 1 Gruppo A, B, C, D, E, F, G; T4; Ta = 40 °C Aex ib IIC T4; IP65; Tipo 4	
Approvazioni Ufficio Pesì e Misure		OIML Classe II, III, IIII NTEP Classe II, III	
Interfacce		1 interfaccia RS232-IS e 1 interfaccia bilancia integrata 1 interfaccia di comunicazione opzionale addizionale	1 interfaccia RS232-IS e 1 interfaccia bilancia integrata 1 interfaccia di comunicazione opzionale addizionale 1 interfaccia bilancia opzionale addizionale
Applicazioni		Pesata lineare Pesata media Stampa intelligente	Pesata lineare Pesata media Stampa intelligente Pesata di controllo più/meno Conteggio Totalizzazione Database Procedure guidate Memoria alibi

Interfaccia bilancia analogica (solo ICS466x)	
Impedenza	80 ... 3.000 Ohm
Tensione di eccitazione	3,3 V
Sensibilità	fino a 3 mV/V
Risoluzione massima	10.000 e (OIML) 300.000 d (non approvabile)
Intervallo di verifica minimo	0,26 μ V/e

Disegno quotato serie ICS4_6x

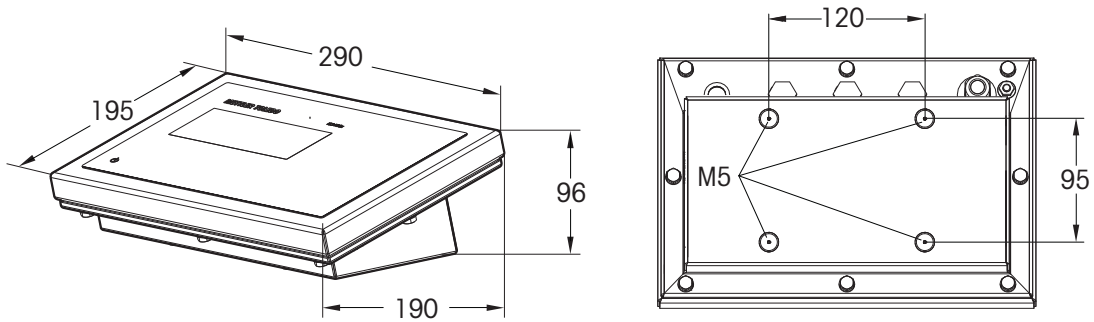

METTLER TOLEDO Service

Hartelijk gefeliciteerd dat u hebt gekozen voor de kwaliteit en precisie van METTLER TOLEDO. Zorgvuldig gebruik van uw nieuwe apparatuur conform deze handleiding en regelmatige kalibratie en onderhoud door onze professionele klantenservice verzekeren een langdurig betrouwbare werking en waardebehoud van uw meetapparatuur. Neem contact met ons op voor een service-overeenkomst afgestemd op uw behoeften en budget. Zie voor meer informatie

www.mt.com/service

Er zijn een aantal manieren om het meeste te halen uit uw investering:

- 1 **Registreer uw product:** Registreer uw nieuwe product onder www.mt.com/productregistration zodat wij u kunnen informeren over verbeteringen, updates en andere belangrijke mededelingen betreffende uw product.
- 2 **Neem contact op met METTLER TOLEDO voor service:** de waarde van een meting is evenredig aan de nauwkeurigheid ervan – een weegschaal die weegt buiten zijn specificaties kan kwaliteit en winstgevendheid verminderen en aansprakelijkheidsrisico's vergroten. Tijdige service door METTLER TOLEDO garandeert de nauwkeurigheid en optimaliseert de beschikbaarheid en levensduur van de apparatuur.
 - ⇒ **Installatie, configuratie, integratie en training:** Onze servicemonteurs zijn professioneel getrainde experts op het gebied van weegapparatuur. Wij zorgen ervoor dat uw weegapparatuur gebruiksklaar is, vlot en tegen lage kosten, en dat uw personeel succesvol is geïnstrueerd.
 - ⇒ **Initiële kalibratiedocumentatie:** De installatie-omgeving en randvoorwaarden van de toepassing zijn uniek voor elke industriële weegschaal, daarom moeten de prestaties worden getest en gecertificeerd. Onze kalibratiediensten en -certificaten documenteren de nauwkeurigheid voor een juiste productiekwaliteit in het kader van een kwaliteitssysteem.
 - ⇒ **Periodieke kalibratie:** Een kalibratieservice-overeenkomst verschaft blijvende zekerheid dat uw weegproces en documentatie in overeenstemming zijn met de eisen. Wij bieden diverse serviceschema's, afgestemd op uw behoeften en budget.

Inhoudsopgave

1	Veiligheidsinstructies	3
1.1	Bedoeld gebruik.....	3
1.2	Niet-bedoeld gebruik.....	3
1.3	Veiligheidsaanwijzingen voor gebruik in explosiegevaarlijke gebieden.....	3
2	Inleiding	4
2.1	Weegterminals van de ICS4_6x-serie.....	4
2.2	Over dit document.....	4
2.3	Overige documenten.....	4
3	Installatie	5
3.1	Installatie, configuratie, service en reparaties.....	5
3.2	Waterpas afstellen.....	5
4	Gebruik	6
4.1	Display.....	6
4.2	Toetsenbord.....	8
4.3	In-/uitschakelen.....	9
4.4	Nullen.....	9
4.5	Normaal wegen.....	9
4.6	Tarreren.....	10
4.7	Gegevens afdrukken of overdragen.....	10
4.8	Wisselen van gewichtseenheid.....	10
4.9	Tellen (uitsluitend ICS466x).....	11
4.10	Over/onder controlewegen (uitsluitend ICS466x).....	12
4.11	Totaliseren (uitsluitend ICS466x).....	13
5	Onderhoud	14
5.1	Reinigen.....	14
5.2	Afvoeren.....	14
6	Technische gegevens	15



1 Veiligheidsinstructies

1.1 Bedoeld gebruik

Weegterminals van de ICS4_6x-serie maken deel uit van een modulaair weegstelsel bestaande uit een METTLER TOLEDO weegterminal als display en ten minste één weegplatform.

De weegterminals van de ICS4_6x-serie zijn goedgekeurd voor gebruik in explosiegevaarlijke gebieden conform Categorie 2 / Divisie 1.

- Gebruik de weegterminal uitsluitend voor weegwerkzaamheden in overeenstemming met deze Verkorte handleiding en de overeenkomstige Bedieningshandleiding.
- De weegterminal is uitsluitend bedoeld voor gebruik binnenshuis.
- Elk ander gebruik wordt beschouwd als niet-bedoeld gebruik.

Wettelijke metrologie

- Gebruik uitsluitend goedgekeurde weegsystemen voor gebruik dat valt onder wettelijke metrologie.
- Bij gebruik voor wettelijke metrologie is de gebruiker verantwoordelijk voor naleving van alle nationale weeg- en meetvoorschriften.
- Neem contact op met de METTLER TOLEDO service-organisatie bij vragen over het gebruik voor wettelijke handelstoepassingen.

1.2 Niet-bedoeld gebruik

- Gebruik de weegterminal niet voor andere werkzaamheden dan wegen.
- Breng geen wijzigingen aan aan de weegterminal.
- Gebruik de weegterminal niet buiten de grenzen van de technische specificaties.

1.3 Veiligheidsaanwijzingen voor gebruik in explosiegevaarlijke gebieden

De weegterminals van de ICS4_6x-serie zijn goedgekeurd voor gebruik in explosiegevaarlijke gebieden conform Categorie 2 / Divisie 1.

De gebruiker is verantwoordelijk voor een veilig gebruik van het explosieveilige weegstelsel.



GEVAAR

Explosiegevaar

- 1 Neem de instructies van de gebruiker in acht.
- 2 Neem alle nationale wet- en regelgeving voor gebruik in explosiegevaarlijke gebieden in acht, naast de instructies en informatie in deze Verkorte handleiding.

2 Inleiding

2.1 Weegterminals van de ICS4_6x-serie

Deze Verkorte handleiding betreft de hieronder vermelde weegterminals:

Type	Numeriek toetsenbord	Softtoetsen	Omgeving	Terminal- en platformcombinatie
ICS426x	–	–	Categorie 2 / Divisie 1	met PBK9-/PFK-9 serie met optie Categorie 2 / Divisie 1
ICS466x	x	x		optioneel, bv. met PBK9-/PFK-9 serie met optie Categorie 2 / Divisie 1 of PBA430x

Weegschaalinterfaces

Weegterminals van de ICS4_6x-serie zijn beschikbaar met met diverse weegschaalinterfaces. De ingebouwde weegschaalinterface wordt direct na het terminaltype vermeld.

ICS4_6xa	...d
Weegschaalinterface	analoog (uitsluitend ICS466x)	IDNet / SICSpr

2.2 Over dit document



Dit document bevat alle informatie voor de **bediener** van de weegterminals van de ICS4_6x-serie.

- Lees dit document zorgvuldig door voor gebruik.
- Bewaar dit document voor toekomstig gebruik.
- Geef dit document door aan de eventuele toekomstige eigenaar of gebruiker van het product.

2.3 Overige documenten

Naast dit gedrukte document kunt u onderstaande documenten downloaden van <http://www.mt.com>:

- Operator handleidingen
- Technische handleidingen
- Installatiehandleidingen
- Databladeren
- Video's
- Brochures
- Typegoedkeuringsdocumenten
- Voor terminal- en platformcombinaties: Bedieningshandleidingen van de aangesloten weegplatformen

Typegoedkeuringsdocumenten

ICS4_6x	Categorie 2	BVS 13 ATEX E042X IECEX BVS 13.0050X
	Divisie 1	FM16US00098

3 Installatie

3.1 Installatie, configuratie, service en reparaties

- Neem voor installatie, configuratie, service en reparatie van explosieveilige weegsystemen contact op met de METTLER TOLEDO service.

3.2 Waterpas afstellen

ICS4_6x weegterminals zijn verkrijgbaar als terminal- en platformcombinatie.

Uitsluitend een nauwkeurig waterpas afgesteld weegplatform geeft nauwkeurige weegresultaten. Weegplatformen goedgekeurd conform de weegen meetrichtlijnen zijn voorzien van een waterpas om deze eenvoudig te kunnen afstellen.

- Verdraai de stelpoten van het weegplatform tot de luchtbel van de waterpas zich in de binnenste cirkel bevindt.

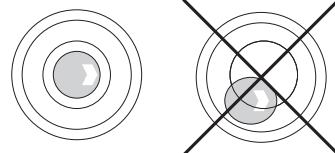

4 Gebruik

4.1 Display

4.1.1 Standaard layout

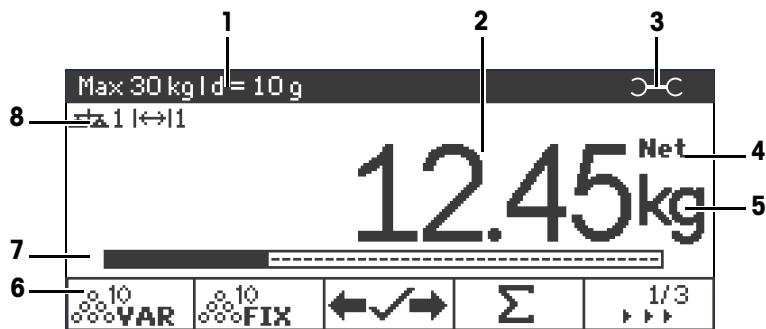

- 1 Metrologiegegevensregel
- 2 Gewichtswaarde
- 3 Gereedschappictogram: service vereist
- 4 Netto/Bruto
- 5 Unit
- 6 Softtoetsen (standaardinstelling, pagina 1; uitsluitend ICS466x)
- 7 Extra gegevensregel: De inhoud wordt gedefinieerd in het menu, zie de Bedieningshandleiding.
- 8 Pictogram- en inforegel

Metrologiegegevensregel



i De metrologiegegevens zijn opgeslagen op het weegplatform. De weegterminal geeft deze slechts weer.

Op de metrologiegegevensregel wordt onderstaande informatie weergegeven:

Pictogram	Information
	Nauwkeurigheidsklassen
W1 , W2 , W3	Weegbereikinformatie
Max , cap	Maximumcapaciteit
Min	Minimumcapaciteit
e =	Goedgekeurde resolutie
d =	Displayresolutie
Approved scale	Goedgekeurd weegapparaat
-10 °C ... +40 °C	Temperatuurbereik





4.1.2 Gewichtswaarde

De gewichtswaarde kan zijn gemarkeerd met onderstaande pictogrammen:

Pictogram	Information
	Berekende gewichtswaarde
	Minteken voor negatieve gewichtswaarden
	Stabiliteitsmonitor voor onstabiele gewichtswaarden
1.234₃ kg	Niet-goedgekeurd laatste cijfer met $e > d$

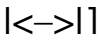





4.1.3 Pictogram- en inforegel

Op de pictogram- en inforegel kan onderstaande informatie worden weergegeven. Zie voor meer pictogrammen de Bedieningshandleiding.

Pictogram	Information	Beschikbaarheid
	Weegschaalnummer	Niet voor ICS426x
	Weegbereik	Uitsluitend voor weegschalen met meerdere bereiken of intervallen
	Gewicht onder minimumgewicht	
	Automatisch tarreren	
	Automatisch wissen van het tarragewicht	
>0<	Nulindicatie	Afhankelijk van de lokale weeg- en meetrichtlijnen
Σ	Totaliseren	Niet voor ICS426x
Fact	Kalibratie vereist	Uitsluitend weergegeven als de functie wordt ondersteund door het weegplatform, bv. de PBK9-/PFK9-serie







4.2 Toetsenbord

4.2.1 Functietoetsen

Toets	Naam	Toets	Naam
	Voeding		Tarra
	Wissen		Info
	Wisselen		Overdragen
	Zero		

4.2.2 Belangrijkste sofftoetsen (uitsluitend ICS466x)

Om tegemoet te komen aan de specifieke eisen van uw toepassing zijn ICS466x weegterminals voorzien van sofftoetsen, die kunnen worden geconfigureerd in het menu. Zie voor meer sofftoetsen de Bedieningshandleiding.

ICS4_6x	Menu-instelling	Functie
	Ref n var	Gemiddeld stuksgewicht bepalen, vrij aanpasbaar
	Ref n fix	Gemiddeld stuksgewicht bepalen, vaste referentiewaarden
	Gewicht/aantal	Wisselen tussen gewichts- en stuksweergave
	Totaliseren	Totaliseren starten
	Over/onder controlewegen	Parameters invoeren voor over/onder controlewegen
	Artikel opslaan	Huidige artikelparameters opslaan in de databank
	Artikel opvragen	Parameters opvragen uit de databank

4.3 In-/uitschakelen

Inschakelen

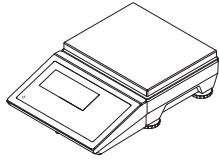

Uitschakelen

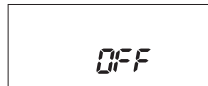
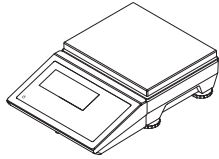

Houd  ingedrukt tot **OFF** wordt weergegeven.

4.4 Nullen

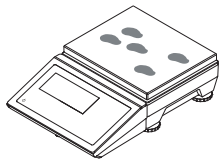

Nullen corrigeert de invloed van kleine veranderingen op het weegplateau of kleine afwijkingen van het nulpunt.

4.5 Normaal wegen

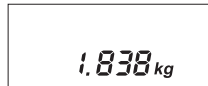
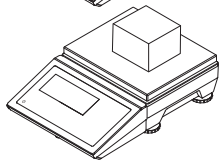
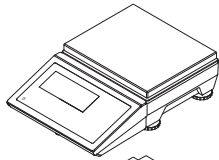

4.6 Tarreren

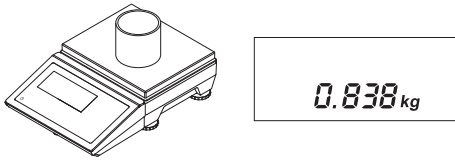

Wanneer de weegschaal is getarreerd, wordt de aanduiding NET weergegeven.

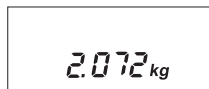
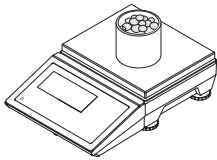

Wanneer de tarra wordt gewist, wordt het bruto gewicht weergegeven.

4.7 Gegevens afdrukken of overdragen

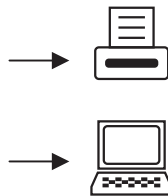
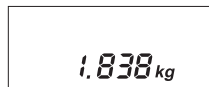
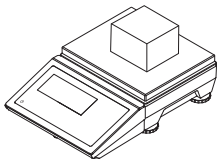

- De printer of computer moet zich in het veilige gebied bevinden.
- De gegevens moeten naar het veilige gebied worden overgedragen via de ACM200 interfaceconverteer.

4.8 Wisselen van gewichtseenheid

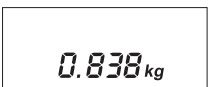
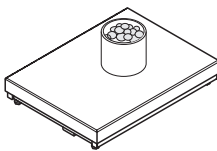

4.9 Tellen (uitsluitend ICS466x)

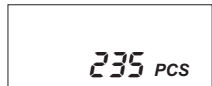
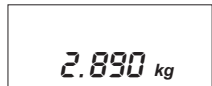
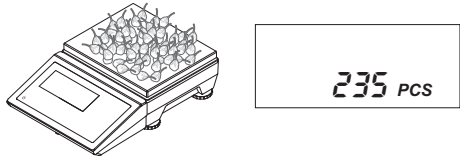
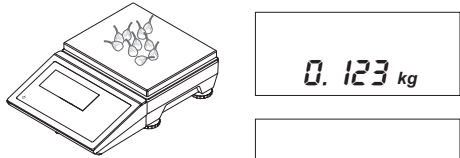
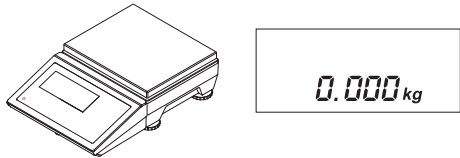

Tellen wissen

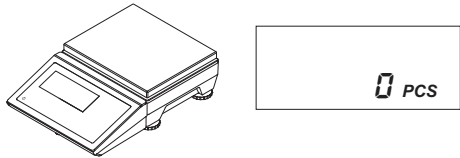







Gebruik het aantal referentieproducten zoals vermeld op de sofftoets, in dit voorbeeld: 10 stuks.

Wissel tussen weergave van het aantal stuks en het gewicht.

Druk op de **C**-toets om de telparameters te wissen. Het gewicht wordt weergegeven.

4.10 Over/onder controlewegen (uitsluitend ICS466x)

Instellen doelwaarden

	Tol. type: Absolute Low: 0.00 kg High: 0.00 kg
	Tol. type: Absolute Low: 0.00 kg High: 0.00 kg
	Tol. type: Absolute Low: 9.5 kg High: 0.00 kg
	Tol. type: Absolute Low: 9.5 kg High: 0.00 kg
	Tol. type: Absolute Low: 9.5 kg High: 10.4 kg
	New target set!



Lw: 9.50kg

HI: 10.40kg

Zie voor andere tolerantietype de Bedieningshandleiding.

U kunt het doelgewicht wegen of handmatig invoeren.

Display voor over/onder controlewegen

	Gewicht binnen tolerantie
	Gewicht boven tolerantie
	Gewicht onder tolerantie

Over/onder controlewegen verlaten

- ESC** Verlaat over/onder controlewegen, maar behoud de doelwaarden.
- C** Verlaat over/onder controlewegen en wis de doelwaarden.

4.11 Totaliseren (uitsluitend ICS466x)

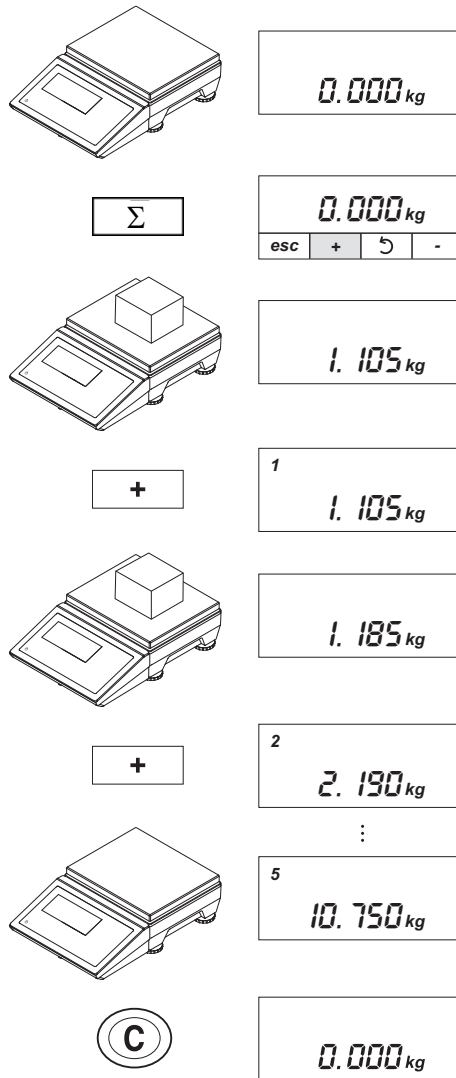

De softtoetsen voor totaliseren worden weergegeven.

1^{ste} product getotaliseerd.

Maak de weegschaal leeg en plaats het 2^{de} product.

2^{de} product getotaliseerd.

5 producten getotaliseerd en het laatste product verwijderd.

Totaal gewist

5 Onderhoud

Onderhoud van de weegterminal is beperkt tot regelmatig reinigen.

5.1 Reinigen



WAARSCHUWING

Explosiegevaar

- 1 Neem de instructies van de gebruiker in acht.
- 2 Voorkom elektrostatische oplading door het dragen van geschikte werkkleding bij bediening in explosiegevaarlijke gebieden.

Aanwijzingen voor reiniging

- Gebruik uitsluitend een schone, vochtige doek en veeg voorzichtig over het toetsenbord.
- Gebruik water of zachte, niet-schurende reinigingsmiddelen.
- Spuit geen reinigingsmiddel direct op de weegterminal.
- Gebruik geen zuren, logen of sterke oplosmiddelen.
- Reinig de weegterminal niet met hoge druk of heet water.
- Neem alle voorschriften in acht betreffende reinigingsintervallen en toegestane reinigingsmiddelen.
- Gebruik geen perslucht of vacuüm.
- Verwijder stofafzettingen.

5.2 Afvoeren

Conform de eisen van de Europese richtlijn 2002/96/EG betreffende afgedankte elektrische en elektronische apparatuur (AEEA) mag dit apparaat niet worden afgevoerd met het huishoudelijk afval. Dit geldt tevens voor landen buiten de EU conform de daar geldende voorschriften.

- Voer dit product in overeenstemming met de lokale voorschriften af naar een inzamelpunt voor elektrische en elektronische apparatuur.



Neem contact op met de verantwoordelijke instantie of met de verkoper waar u dit apparaat hebt gekocht wanneer u vragen hebt.

Wanneer dit apparaat wordt doorgegeven (voor privé- of commercieel/industriële gebruik) moet deze aanwijzing eveneens worden doorgegeven.

Hartelijk dank voor uw bijdrage aan de bescherming van het milieu.

6 Technische gegevens

Weegterminals		ICS426x	ICS466x
Behuizing		Roestvrij staal	
Display		Monochroom grafisch LCD Achtergrondverlichting	Monochroom grafisch LCD Gekleurde achtergrondverlichting
Toetsenbord		Aanrakingsgevoelig membraantoetsenbord (PET), krasbestendige opschriften	
Netto gewicht		2,8 kg / 6,1 lb	
Beschermingsklasse		IP65	
Netvoeding		via APS768x	
Omgevingsvoorwaarden	Toepassing	uitsluitend voor gebruik binnenshuis	
	Temperatuurbereik Klasse III	-10 °C ... 40 °C / 14 °F ... 104 °F	
	Luchtvochtigheid	Max. rel. luchtvochtigheid 85 % voor temperaturen tot 40 °C / 104 °F	
Type ontstekingsbescherming	EN/IECEx	II 2G Ex ib IIC T4 Gb, -10 °C ... +40 °C II 2D Ex ib IIIC T60°C Db IP65	
	cFM _{US}	IS Klasse I, II, III; Divisie 1 Groep A, B, C, D, E, F, G; T4; Ta = 40 °C AEx ib IIC T4; IP65; Type 4	
Metrologiekeurmerken		OIML Klasse II, III, IIII NTEP Klasse II, III	
Interfaces		1 interface RS232-IS en 1 weegschaalinterface geïntegreerd 1 optionele tweede communicatie-interface	1 interface RS232-IS en 1 weegschaalinterface geïntegreerd 1 optionele tweede communicatie-interface 1 optionele tweede weegschaalinterface
Toepassingen		Normaal wegen Gemiddeld wegen Slim afdrukken	Normaal wegen Gemiddeld wegen Slim afdrukken Over/onder controlewegen Tellen Totaliseren Databank Promptstand Alibi-geheugen

Analoge weegschaalinterface (uitsluitend ICS466x)	
Impedantie	80 ... 3.000 Ohm
Bekrachtiging	3,3 V
Gevoeligheid	tot 3 mV/V
Max. resolutie	10.000 e (OIML) 300.000 d (niet keurbaar)
Min. keuringsinterval	0,26 μ V/e

Maattekening ICS4_6x-serie

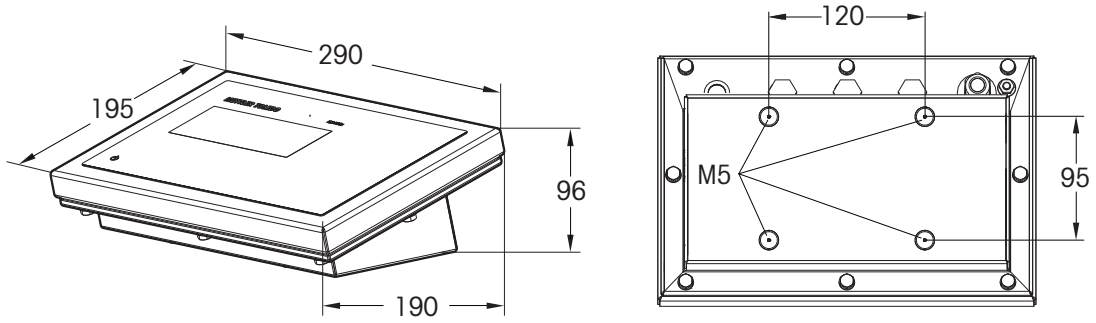

METTLER TOLEDO Service

Parabéns por escolher a qualidade e precisão da METTLER TOLEDO. O uso adequado de seu novo equipamento de acordo com este manual e a calibração e manutenção regulares feitas por nossa equipe treinada na fábrica garante uma operação confiável e precisa, protegendo o seu investimento. Entre em contato para discutirmos um contrato de serviço adequado às suas necessidades e ao seu orçamento. Mais informações estão disponíveis em

www.mt.com/service

Há vários meios importantes para garantir que o desempenho de seu investimento seja o ideal:

- 1 **Registre seu produto:** Convidamos você a registrar seu produto em www.mt.com/productregistration para que possamos informá-lo sobre melhorias, atualizações e notificações importantes sobre o seu produto.
- 2 **Se precisar de serviço, fale com a METTLER TOLEDO:** O valor de uma medição é proporcional à sua exatidão – uma balança fora da especificação pode reduzir a qualidade, diminuir os lucros e aumentar a responsabilidade. A manutenção da METTLER TOLEDO em tempo hábil garante a exatidão e otimiza o tempo de operação e a vida do equipamento.
 - ⇒ **Instalação, configuração, integração e treinamento:** Nossos representantes de serviços treinados na fábrica são especialistas em equipamentos de pesagem. Asseguramos que seu equipamento de pesagem está pronto para produzir de maneira rentável e no momento adequado e que o pessoal é treinado para o sucesso.
 - ⇒ **Documentação de calibração inicial:** O ambiente de instalação e os requisitos da aplicação são peculiares para cada balança industrial, por isso o desempenho deve ser testado e certificado. Nossos serviços de calibração e certificados documentam a exatidão para garantir a qualidade da produção e fornecer um registro de desempenho para o sistema de qualidade.
 - ⇒ **Manutenção da calibração periódica:** Um Contrato de Serviço de Calibração confere confiabilidade contínua ao seu processo de pesagem e uma documentação de conformidade aos requisitos. Oferecemos uma variedade de planos de serviço programados para atender às suas necessidades e idealizados para se adequarem a seu orçamento.

Índice remissivo

1	Instruções de segurança	3
1.1	Utilização prevista.....	3
1.2	Uso indevido	3
1.3	Observações de segurança para operação em áreas de risco	3
2	Introdução	4
2.1	Terminais de pesagem da série ICS4_6x	4
2.2	Sobre este documento	4
2.3	Outros documentos.....	4
3	Instalação	5
3.1	Instalação, configuração, manutenção e reparo	5
3.2	Nivelamento.....	5
4	Operação	6
4.1	Mostrador	6
4.2	Teclado	8
4.3	Ligar/desligar	9
4.4	Zerar valores	9
4.5	Pesagem direta	9
4.6	Uso das taras.....	10
4.7	Impressão ou transferência de dados.....	10
4.8	Mudança de unidade de peso	10
4.9	Contagem (apenas ICS466x).....	11
4.10	Sobre/Sob Pesagem de verificação (apenas ICS466x).....	12
4.11	Totalização (apenas ICS466x).....	13
5	Manutenção	14
5.1	Limpeza	14
5.2	Descarte	14
6	Ficha técnica	15

1 Instruções de segurança

1.1 Utilização prevista

Os terminais de pesagem da série ICS4_6x fazem parte de um sistema modular de pesagem protegido contra explosão que consiste em um terminal de pesagem METTLER TOLEDO como indicador e, no mínimo, uma plataforma de pesagem.

Os terminais de pesagem da série ICS4_6x são aprovados para operar em áreas de risco da Categoria 2 / Divisão 1.

- Use o terminal de pesagem apenas para pesar, de acordo com este Guia rápido e o Manual de usuário correspondente.
- O terminal de pesagem só deve ser usado em ambientes fechados.
- Qualquer outra forma de uso é considerada como não apropriada.

Metrologia legal

- Para uso em metrologia legal, use apenas os sistemas de pesagem aprovados.
- Ao usar em metrologia legal, a empresa operadora é responsável por observar todas as exigências nacionais de pesos e medidas.
- Por favor, contate a organização de serviço da METTLER TOLEDO para questões relacionadas ao uso em aplicações legais para o comércio.

1.2 Uso indevido

- Use o terminal de pesagem apenas para operações de pesagem.
- Não altere o terminal de pesagem.
- Não use o terminal de pesagem fora dos limites das especificações técnicas.

1.3 Observações de segurança para operação em áreas de risco

Os terminais de pesagem da série ICS4_6x são aprovados para operar em áreas de risco da Categoria 2 / Divisão 1.

A empresa operadora é responsável pela operação segura do sistema de pesagem protegido contra explosões.



PERIGO

Risco de explosão

- 1 Observe rigorosamente as instruções da empresa operadora.
- 2 Atue em conformidade com todas as normas nacionais para operação em áreas de risco, bem como com as instruções e informações deste Guia rápido.

2 Introdução

2.1 Terminais de pesagem da série ICS4_6x

Este Guia rápido se concentra nos seguintes terminais de pesagem:

Tipo	Teclado numérico	Teclas de função	Meio ambiente	Combinação de terminal e plataforma
ICS426x	–	–	Categoria 2 / Divisão 1	com série PBK9-/PFK-9 com opção de Categoria 2 / Divisão 1
ICS466x	x	x		opcional, por ex., com série PBK9-/PFK-9 com opção de Categoria 2 / Divisão 1 ou PBA430x

Interfaces de balança

Os terminais de pesagem da série ICS4_6x estão disponíveis com diversas interfaces de balança. A interface de balança integrada é indicada diretamente após o tipo de terminal.

ICS4_6xa	...d
Interface da balança	analógica (apenas ICS466x)	IDNet / SICSpro

2.2 Sobre este documento



Este documento contém todas as informações para o **operador** dos terminais de pesagem da série ICS4_6x.

- Leia este documento com atenção antes de usar.
- Guarde este documento para futuras consultas.
- Repasse este documento para possíveis proprietários ou usuários futuros do produto.

2.3 Outros documentos

Além deste documento impresso, você pode fazer o download dos seguintes documentos em <http://www.mt.com>:

- Manuais do operador
- Manuais técnicos
- Manuais de instalação
- Fichas de dados
- Vídeos
- Folhetos
- Documentos do tipo de aprovação
- Para combinações de terminal e plataforma: Manuais do usuário das plataformas de pesagem conectadas

Documentos do tipo de aprovação

ICS4_6x	Categoria 2	BVS 13 ATEX E042X IECEX BVS 13.0050X
	Divisão 1	FM16US00098

3 Instalação

3.1 Instalação, configuração, manutenção e reparo

- Para a instalação, configuração, manutenção e reparo de um sistema de pesagem protegido contra explosão, ligue para o serviço da METTLER TOLEDO.

3.2 Nivelamento

Os terminais de pesagem ICS4_6x estão disponíveis como combinação de terminal e plataforma.

Apenas as plataformas de pesagem horizontalmente niveladas com precisão fornecem resultados de pesagem precisos. As plataformas aprovadas de Pesos e Medidas possuem uma bolha de nível para simplificar o nivelamento.

- Gire o pé ajustável da plataforma de pesagem até que a bolha de ar do nível esteja dentro do círculo interno.

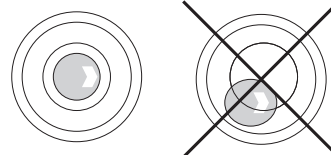

4 Operação

4.1 Mostrador

4.1.1 Esquema padrão

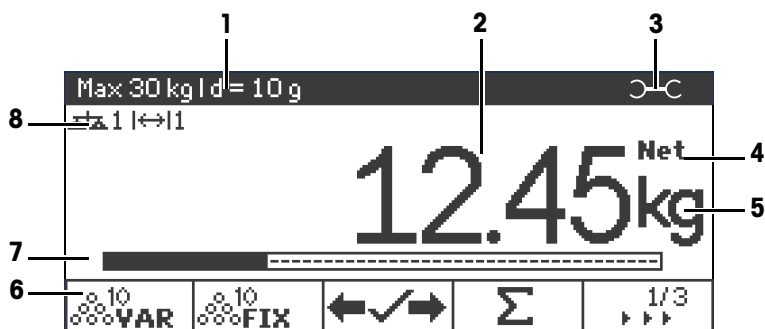

- 1 Linha de dados metrológicos
- 2 Valor de peso
- 3 Ícone de chave: serviço necessário
- 4 Líquido/Bruto
- 5 Unidade
- 6 Teclas de função (configuração de fábrica, página 1, apenas ICS466x)
- 7 Linha de dados auxiliar: O conteúdo é definido no menu, consulte o Manual de usuário.
- 8 Linha de símbolos e informações

Linha de dados metrológicos



i Os dados metrológicos são armazenados na plataforma de pesagem. O terminal de pesagem serve apenas como indicador.

Na linha de dados metrológicos, as seguintes informações são exibidas:

Símbolo	Informações
	Classes de precisão
W1 , W2 , W3	Informações da faixa de pesagem
Max , cap	Capacidade máxima
Min	Capacidade mínima
e =	Resolução aprovada
d =	Resolução do mostrador
Approved scale	Dispositivo de pesagem aprovado
-10 °C ... +40 °C	Intervalo de temperatura





4.1.2 Valor de peso

O valor de peso pode ser marcado com os seguintes símbolos:

Símbolo	Informações
	Valor de peso calculado
	Sinal para valores negativos de peso
	Monitor de estabilidade para valores instáveis de peso
1.234₃ kg	Último dígito não aprovado com e > d







4.1.3 Símbolos e linha de informações

As seguintes informações podem ser exibidas na linha de símbolos e informações: Para ver mais símbolos, consulte o Manual do usuário.

Símbolo	Informações	Disponibilidade
	Número da balança	Não disponível para ICS426x
<->	Faixa de pesagem	Apenas para balanças com diversas faixas ou intervalos
	Peso abaixo do peso mínimo	
	Tara automática	
	Limpeza automática do peso da tara	
>0<	Indicação de centro de zero	Dependência dos regulamentos locais de Pesos e Medidas
Σ	Totalização	Não disponível para ICS426x
Fact	FACT precisa estar concluído	Exibido apenas se a função for compatível com a plataforma de pesagem, por ex., a série PBK9-/PFK9







4.2 Teclado

4.2.1 Teclas de função

Tecla	Nome	Tecla	Nome
	Ligar		Tara
	Limpar		Informações
	Comutação		Transferência
	Zero		

4.2.2 Principais teclas de função (apenas ICS466x)

Para atender às suas exigências específicas de aplicação, os terminais de pesagem ICS466x oferecem teclas de função que podem ser configuradas no menu. Para ver mais teclas de função, consulte o Manual do usuário.

ICS4_6x	Configuração do menu	Função
	Ref n var	Determine o peso médio da peça, livremente ajustável
	Ref n fix	Determine o peso médio da peça, tamanhos de referência fixos
	Peso/contagem	Altere entre a exibição de peso e a exibição de peças
	Totalizando	Iniciar totalização
	Sobre/Sob Pesagem de verificação	Insira os parâmetros do modo Sobre/Sob Pesagem de verificação
	Salvar artigo	Salvar os parâmetros de artigo atuais no banco de dados
	Chamar artigo novamente	Chamar parâmetros do banco de dados novamente

4.3 Ligar/desligar

Ligando

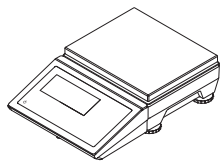

Desligando

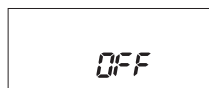
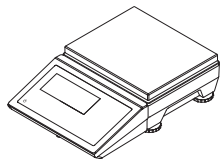

Mantenha a tecla  pressionada até que **OFF** seja exibido.

4.4 Zerar valores

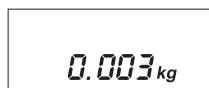
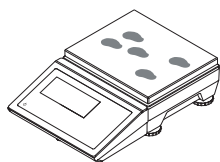

A zeragem de valores corrige a influência de alterações leves na placa de carga ou de desvios menores do ponto zero.

4.5 Pesagem direta

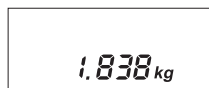
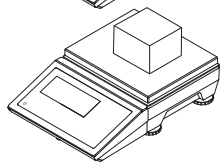
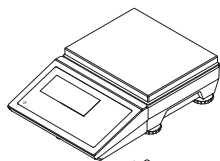

4.6 Uso das taras

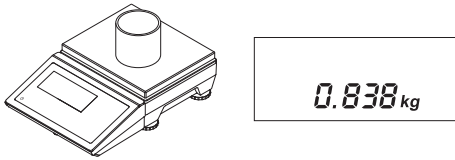

Quando a balança está com a tara definida, o símbolo NET é exibido.

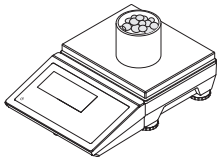

Quando a tara é apagada, o peso bruto é exibido.

4.7 Impressão ou transferência de dados

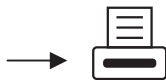
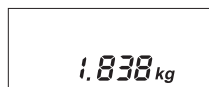
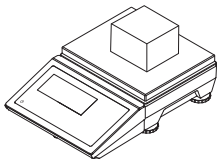

- A impressora ou computador precisam estar na área segura.
- Os dados precisam ser transferidos para a área segura por meio do conversor de interface ACM200.

4.8 Mudança de unidade de peso

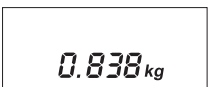
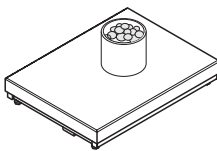

4.9 Contagem (apenas ICS466x)

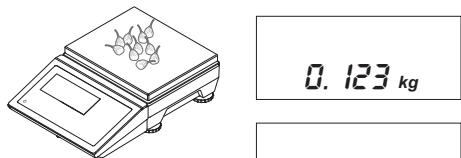
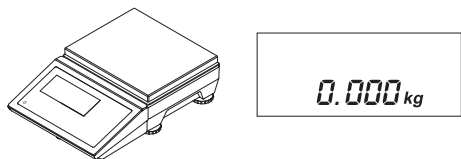

10
VAR
10 PCS

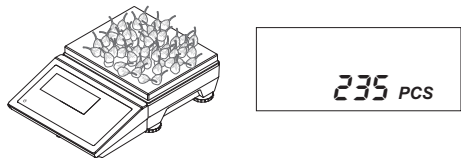

2.890 kg



235 PCS

Apagar contagem

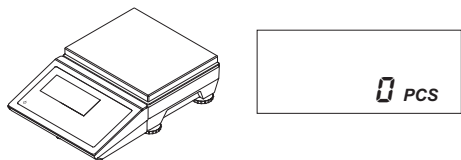

0.000 kg

Use o número de peças de referência indicado na tecla de função, neste exemplo: 10 peças.

Altere entre a exibição do número de peças e a exibição de peso.

Pressione a tecla **C** para apagar os parâmetros de contagem. O peso é exibido.

4.10 Sobre/Sob Pesagem de verificação (apenas ICS466x)

Definir valores desejados

	<table border="1"> <tr><td>Tipo tol.:</td><td>Absoluto</td></tr> <tr><td>Baixo:</td><td>0.00 kg</td></tr> <tr><td>Alto:</td><td>0.00 kg</td></tr> </table>	Tipo tol.:	Absoluto	Baixo:	0.00 kg	Alto:	0.00 kg
Tipo tol.:	Absoluto						
Baixo:	0.00 kg						
Alto:	0.00 kg						
	<table border="1"> <tr><td>Tipo tol.:</td><td>Absoluto</td></tr> <tr><td>Baixo:</td><td>0.00 kg</td></tr> <tr><td>Alto:</td><td>0.00 kg</td></tr> </table>	Tipo tol.:	Absoluto	Baixo:	0.00 kg	Alto:	0.00 kg
Tipo tol.:	Absoluto						
Baixo:	0.00 kg						
Alto:	0.00 kg						
	<table border="1"> <tr><td>Tipo tol.:</td><td>Absoluto</td></tr> <tr><td>Baixo:</td><td>9.5 kg</td></tr> <tr><td>Alto:</td><td>0.00 kg</td></tr> </table>	Tipo tol.:	Absoluto	Baixo:	9.5 kg	Alto:	0.00 kg
Tipo tol.:	Absoluto						
Baixo:	9.5 kg						
Alto:	0.00 kg						
	<table border="1"> <tr><td>Tipo tol.:</td><td>Absoluto</td></tr> <tr><td>Baixo:</td><td>9.5 kg</td></tr> <tr><td>Alto:</td><td>0.00 kg</td></tr> </table>	Tipo tol.:	Absoluto	Baixo:	9.5 kg	Alto:	0.00 kg
Tipo tol.:	Absoluto						
Baixo:	9.5 kg						
Alto:	0.00 kg						
	<table border="1"> <tr><td>Tipo tol.:</td><td>Absoluto</td></tr> <tr><td>Baixo:</td><td>9.5 kg</td></tr> <tr><td>Alto:</td><td>10.4 kg</td></tr> </table>	Tipo tol.:	Absoluto	Baixo:	9.5 kg	Alto:	10.4 kg
Tipo tol.:	Absoluto						
Baixo:	9.5 kg						
Alto:	10.4 kg						
	<table border="1"> <tr><td colspan="2">Nova meta definida!</td></tr> </table>	Nova meta definida!					
Nova meta definida!							

LW: 9.50kg
HI: 10.40kg

Para ver outros tipos de tolerância, consulte o Manual do usuário.

Você pode pesar o peso desejado ou inseri-lo numericamente.

Mostrador do modo Sobre/Sob Pesagem de verificação

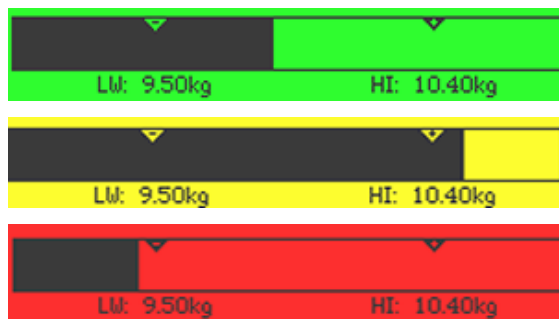

Peso dentro dos valores de tolerância

Peso acima dos valores de tolerância

Peso abaixo dos valores de tolerância

Sair do modo Sobre/Sob Pesagem de verificação

- ESC** Sair do modo Sobre/Sob Pesagem de verificação, mas manter os valores desejados.
- C** Sair do modo Sobre/Sob Pesagem de verificação e apagar os valores desejados.

4.11 Totalização (apenas ICS466x)

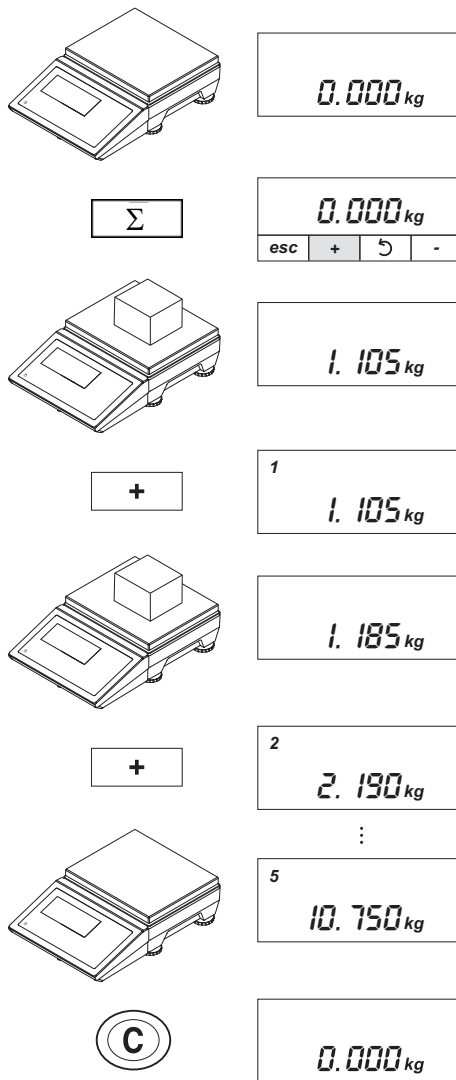

As teclas de função para totalização são exibidas.

1º artigo totalizado.

Descarregue a balança e coloque o 2º artigo.

2º artigo totalizado.

5 artigos totalizados e último artigo removido.

Total apagado.

5 Manutenção

A manutenção do terminal de pesagem é limitada à limpeza regular.

5.1 Limpeza



ATENÇÃO

Risco de explosão

- 1 Observe cautelosamente as instruções da empresa operadora.
- 2 Evite cargas eletrostáticas usando roupas adequadas de trabalho ao operar em áreas de risco.

Observações sobre limpeza

- Use somente um pano limpo úmido e limpe o teclado com cuidado.
- Use água ou produtos de limpeza suaves e não abrasivos.
- Não pulverize o produto de limpeza diretamente sobre o terminal de pesagem.
- Não use substâncias ácidas, alcalinas nem solventes fortes.
- Não limpe o terminal de pesagem com água em alta pressão ou alta temperatura.
- Observe todos os regulamentos existentes sobre intervalos de limpeza e agentes de limpeza admissíveis.
- Não use ar comprimido nem vácuo.
- Remova as camadas de poeira.

5.2 Descarte

Em conformidade com os requisitos da Diretiva Europeia 2002/96 CE sobre Resíduos de Equipamentos Elétricos e Eletrônicos (WEEE), este dispositivo não deve ser eliminado junto com o lixo doméstico. Isto também se aplica para países fora da UE em conformidade com os seus respectivos regulamentos nacionais.

- Descarte este produto de acordo com os regulamentos locais para a coleta separada para resíduos de equipamentos elétricos e eletrônicos.



Se você tiver alguma dúvida, entre em contato com as respectivas autoridades ou o distribuidor onde foi adquirido este dispositivo.

Se este dispositivo foi repassado (por exemplo, para uso privado ou comercial/industrial posterior), este regulamento também deve ser repassado.

Muito obrigado por sua contribuição para a proteção ambiental.

6 Ficha técnica

Terminais de pesagem		ICS426x	ICS466x
Acabamento		Aço inoxidável	
Mostrador		Mostrador gráfico monocromático de LCD Luz de fundo	Mostrador gráfico monocromático de LCD Luz de fundo colorida
Teclado		Teclado de membrana de toque tátil (PET), rotulagem resistente a arranhões	
Peso líquido		2,8 kg / 6,1 lb	
Tipo de proteção		IP65	
Conexão de rede		via APS768x	
Condições ambientais	Aplicação	apenas para uso em ambientes fechados	
	Faixa de temperatura Classe III	-10 °C ... 40 °C / 14 °F ... 104 °F	
	Umidade	Umidade rel. máx. 85 % para temperaturas até 40 °C / 104 °F	
Tipo de proteção de ignição	EN/IECEX	II 2G Ex ib IIC T4 Gb, -10 °C ... +40 °C II 2D Ex ib IIIC T60°C Db IP65	
	cFM _{US}	IS Classe I, II, III; Divisão 1 Grupo A, B, C, D, E, F, G; T4; Ta = 40 °C Aex ib IIC T4; IP65; Tipo 4	
Aprovações W & M		Classe II, III, IIII OIML Classe II, III NTEP	
Interfaces		1 interface RS232-IS e 1 interface de balança integrada 1 interface de comunicação opcional adicional	1 interface RS232-IS e 1 interface de balança integrada 1 interface de comunicação opcional adicional 1 interface de balança opcional adicional
Aplicações		Pesagem direta Pesagem média Impressão inteligente	Pesagem direta Pesagem média Impressão inteligente Sobre/Sob Pesagem de verificação Contagem Totalizando Banco de dados Solicitando Memória de Álubi

Interface de balança analógica (apenas ICS466x)	
Impedância	80 ... 3.000 Ohms
Excitação	3,3 V
Sensibilidade	até 3 mV/V
Resolução máx.	10.000 e (OIML) 300.000 d (não aprovável)
Intervalo mín. de verificação	0,26 μ V/e

Desenho dimensional série ICS4_6x

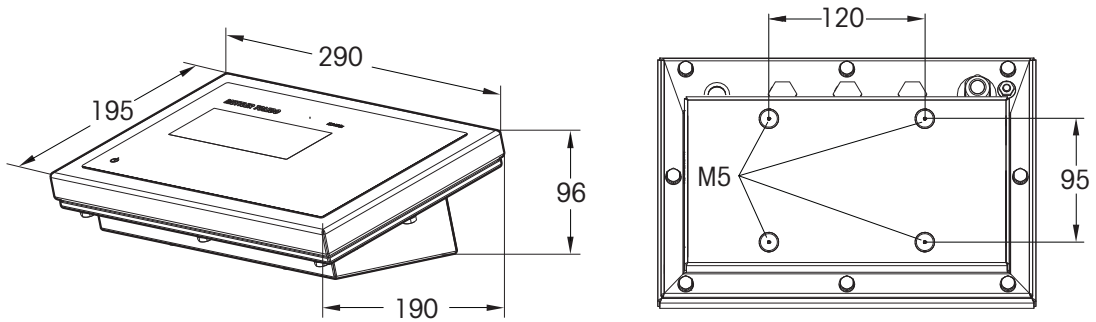

To protect your product's future:
METTLER TOLEDO Service assures
the quality, measuring accuracy and
preservation of value of this product
for years to come.

Please request full details about our
attractive terms of service.

www.mt.com

For more information

Mettler-Toledo GmbH

Im Langacher 44
8606 Greifensee, Switzerland
www.mt.com/contact

Subject to technical changes.
© Mettler-Toledo GmbH 11/2016
30323069B CEU



30323069