

METTLER TOLEDO

Operating Instructions

METTLER TOLEDO Spider BC Counting Scales

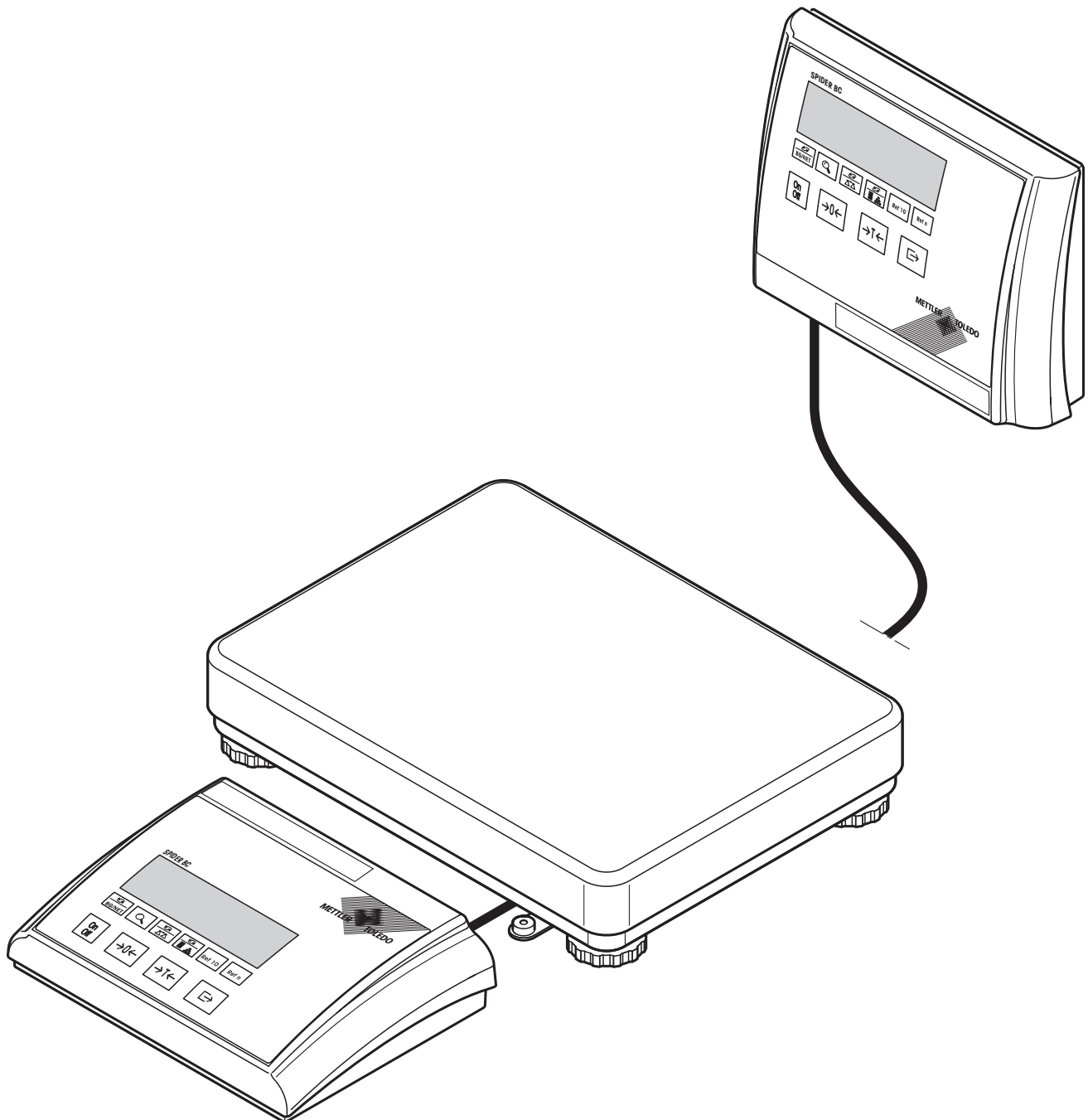

Overview of your Spider BC scale

Overview

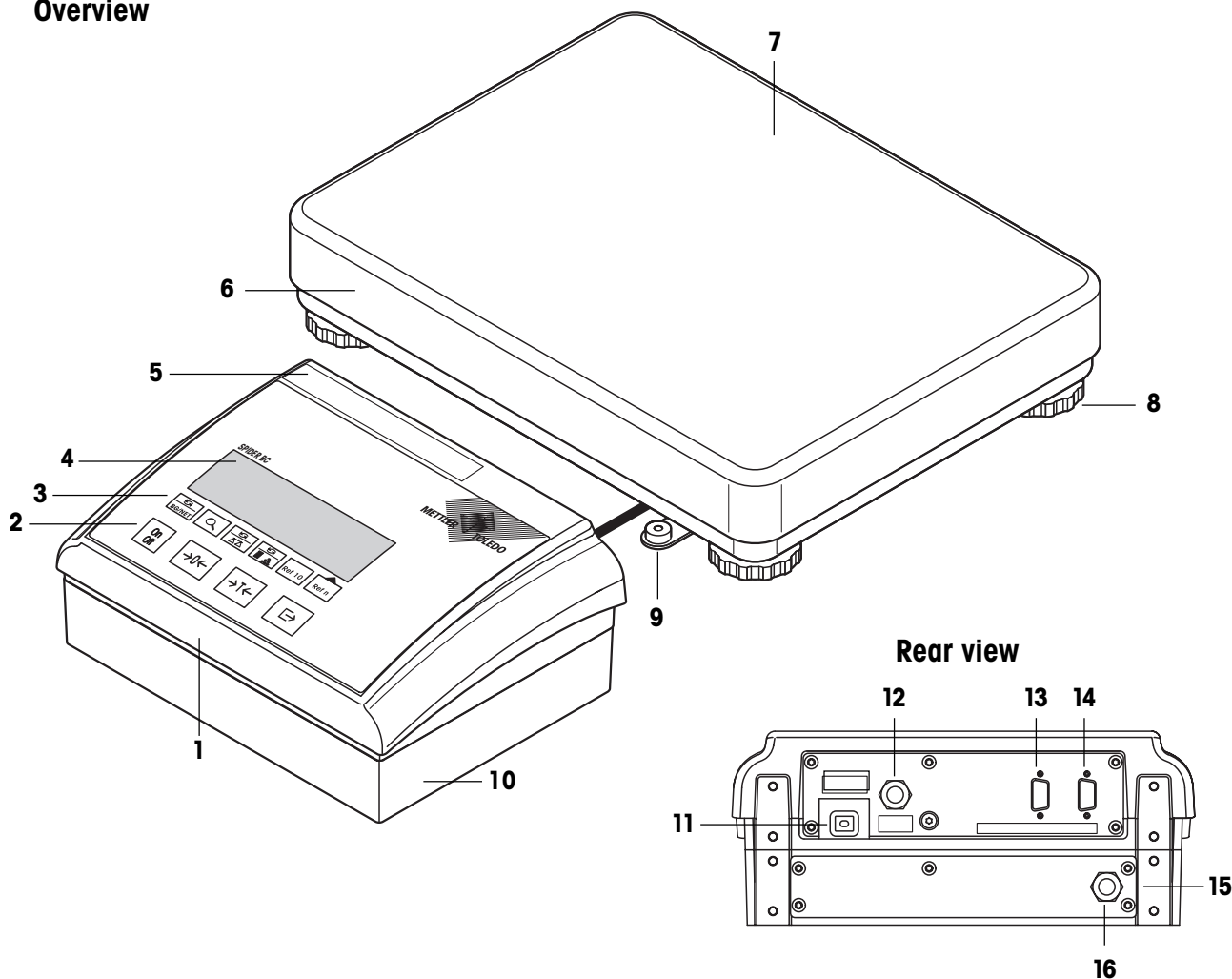

Display

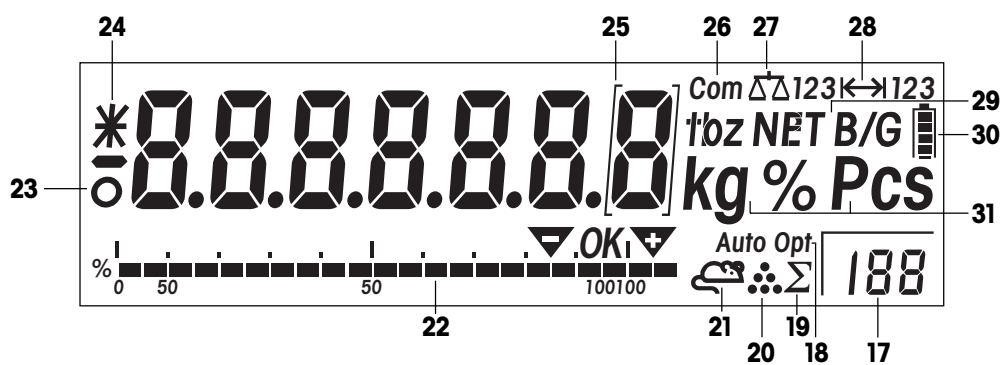

Keypad

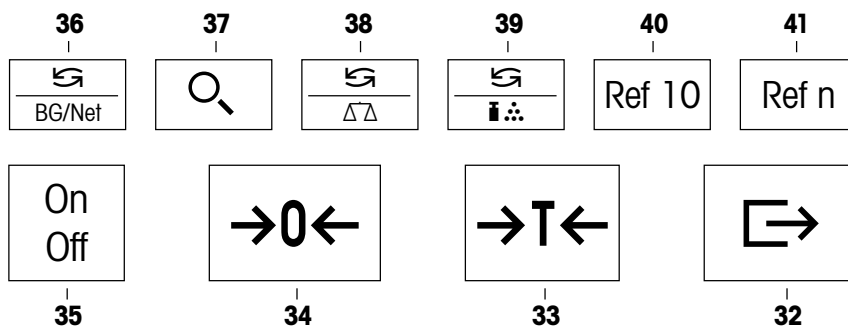

Overview

- 1 Terminal (benchtop version)
- 2 Operating keys (see detailed illustration)
- 3 Function keys (see detailed illustration)
- 4 Display (see detailed illustration)
- 5 Type plate
- 6 Weighing platform
- 7 Weighing pan
- 8 Leveling feet
- 9 Level indicator (certified scales only)
- 10 OptionPac (optional)

Rear view

- 11 Power supply cable
- 12 Connector cable to weighing platform
- 13 Second interface RS232C or RS422/485 (option)
- 14 RS232C interface (standard)
- 15 OptionPac (option)
- 16 Analog interface (option)

Display

- 17 Variable reference piece count
- 18 Automatic reference optimization
- 19 Totalization symbol (has no function)
- 20 Piece counting symbol
- 21 Dynamic weighing display
- 22 Bargraph of weighing range
- 23 Stability detector
- 24 Changed resolution (certified scales only)
- 25 Certification brackets
(only on certified scales with $e = 10d$)
- 26 Active interface (only displayed if more than one interface is installed)
- 27 Active scale (on 2-scale systems)
- 28 Weighing range
- 29 Net/gross weight symbol
- 30 Storage battery charge status (only on scales with storage battery)
- 31 Weighing unit

Keypad

- 32 Transfer key
- 33 Tare key
- 34 Zeroing key
- 35 On/off key
- 36 Gross/net weight display switchover key
- 37 Higher resolution of weight display in weighing mode or weight of a single piece in counting mode. Displays for 3 seconds.
- 38 Scale 1/scale 2 (reference scale/quantity scale) switchover for two-scale operation
- 39 Piece counting/weight display switchover
- 40 Reference determination with 10 pieces
- 41 Reference determination with variable number of pieces

Contents

1	Setting up the scale	6
1.1	Important	6
1.2	Unpacking and checking the delivered items	6
1.3	Safety and environment	6
1.4	Selecting a location and leveling the scale	7
1.5	Connecting the power supply	7
2	Weighing	8
2.1	Switching on/off and setting to zero	8
2.2	Simple weighing	8
2.3	Weighing with tare	9
2.4	Weighing with 2-scale systems	9
2.5	Dynamic weighing	10
3	Piece counting	11
3.1	Counting pieces into a container	11
3.2	Counting pieces out of a container	12
3.3	Automatic reference optimization	12
3.4	Adding mode	13
3.5	Piece counting with two-scale systems	13
4	The menu	14
4.1	Overview and operation	14
4.2	Calling up the menu and entering the password	14
4.3	Menu overview	15
4.4	Scale settings (SCALE)	17
4.4.1	Adjust/calibrate scale (SCALE → Cal)	17
4.4.2	Display accuracy and weighing unit (SCALE → Display)	18
4.4.3	Automatic taring (SCALE → A-Tare)	18
4.4.4	Automatic zero point correction (SCALE → A-Zero)	18
4.4.5	Automatic save of tare and zero values (SCALE → Restart)	19
4.4.6	Adaptation to environmental conditions and weighing mode (SCALE → Filter)	19
4.4.7	Reset scale settings to factory settings (SCALE → Reset)	19
4.5	Application settings (APPLICATION)	20
4.5.1	Settings for piece counting (APPLICATION → Count)	20
4.5.2	Activating the dynamic weighing function (APPLICATION → Dynamic)	20
4.5.3	Reset application settings to factory settings (APPLICATION → Reset)	21
4.6	Terminal settings (TERMINAL)	21
4.6.1	Standby, energy-saving mode, and display backlighting (TERMINAL → Device)	21
4.6.2	Password for menu access (TERMINAL → Access)	22
4.6.3	Reset terminal settings to factory settings (TERMINAL → Reset)	22

4.7	Configure interfaces (COMMUNICATION)	23
4.7.1	Operating mode of interface (COMMUNICATION → Mode)	23
4.7.2	Communication parameters (COMMUNICATION → Parameters)	24
4.7.3	Settings for printed reports (COMMUNICATION → Definition String)	25
4.7.4	Inserting line feeds into the report (COMMUNICATION → Add Line Feed)	26
4.7.5	Reset interface settings to factory settings (COMMUNICATION → Reset)	26
4.8	Diagnosis and printout of menu settings (DIAGNOSTICS)	26
4.8.1	Checking the keyboard (DIAGNOSTICS → Keyboard)	27
4.8.2	Checking the display (DIAGNOSTICS → Display)	27
4.8.3	Display serial number (DIAGNOSTICS → SNR)	27
4.8.4	Printing the menu settings (DIAGNOSTICS → List)	27
4.8.5	Reset all menu settings to the factory settings (DIAGNOSTICS → Reset All)	28
4.9	Saving the settings and quitting the menu (End)	28
5	Additional important information	29
5.1	SICS interface commands	29
5.1.1	Preconditions for communication between scale and PC	29
5.1.2	SICS commands supported by the scale	29
5.1.3	Scale-specific SICS command for defining the report header	29
5.1.4	Network operation via the optional RS422/485 interface	30
5.2	Warning and error messages	30
5.3	Sample reports	31
5.4	Cleaning instructions	31
6	Technical data, interfaces, and accessories	32
6.1	General data and delivered items	32
6.2	Type codes and model-specific data	33
6.2.1	Type codes	33
6.2.2	Model-specific data	33
6.3	Dimensions and weights	34
6.3.1	Terminal	34
6.3.2	Weighing platforms	34
6.4	RS232C and RS422/485 interfaces	35
6.5	Analog option	36
6.6	Accessories	37
6.7	Declaration of conformity	38
6.8	Safety tests	39

1 Setting up the scale

Please read these operating instructions carefully and follow them exactly! If you find that any items are missing or incorrect, or if you have any other problems with your scale, please contact your authorized METTLER TOLEDO representative.

1.1 Important

Various different models of the Spider scale **terminal** are available. Only the **benchtop** model is described in these instructions. If you ordered a **wall- or stand-mount terminal**, please refer to the installation instructions delivered separately. The **OptionPac** (special equipment) can contain a number of options, such as additional interfaces or a storage battery. If you ordered an OptionPac it will have been configured at the factory with the options you requested and fastened below the terminal.

1.2 Unpacking and checking the delivered items

Remove the scale and accessories from the packaging and check the delivered items:

- Terminal and weighing platform with installed weighing pan and level indicator (certified scales only)
- Open-end wrench for leveling the weighing platform
- Operating instructions (this document)
- Special accessories (if any) as per packing list

1.3 Safety and environment

For safe and environmentally harmless operation of your scale, observe the following instructions:



Do not use the scale in **hazardous environments** (unless it is specially marked).

Although the Spider scale is protected to **IP65**, it must not be used in environments where there is a **corrosion hazard**. Never flood the scale or immerse it in liquids!

If the **power supply cable** is damaged, the scale must not be used. Check the cable regularly.



Do not open the weighing platform or terminal since this will void the guarantee. Do not use rigid objects to clean inside the weighing platform.

Treat the scale with care, it is a precision instrument. Avoid knocking the weighing pan or placing excessively heavy loads on it.

If the Spider scale will be used in **food processing areas**: Those parts of the scale which may come into contact with food have a smooth surface and are easy to clean. The materials used do not shatter and contain no harmful substances. In food processing areas, it is advisable to use the **protective cover** (accessory). This must be regularly cleaned like the scale itself. A damaged or heavily soiled protective cover must be replaced immediately.

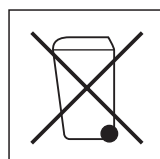

When **disposing of the scale**, observe the applicable environmental regulations. If the scale is fitted with a **storage battery**, note that the battery contains heavy metals and must therefore not be disposed of as normal waste! Observe local regulations for disposal of environmentally harmful substances.

1.4 Selecting a location and leveling the scale

The proper location can influence the accuracy of the weighing results!

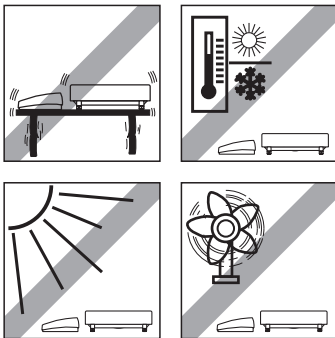

Choose a stable, vibration-free flat surface. The surface must be able to bear the weight of the fully loaded scale safely.

Pay attention to environmental conditions:

- No direct sunlight
- No strong drafts (e.g. from fans or air conditioning)
- No excessive temperature fluctuations

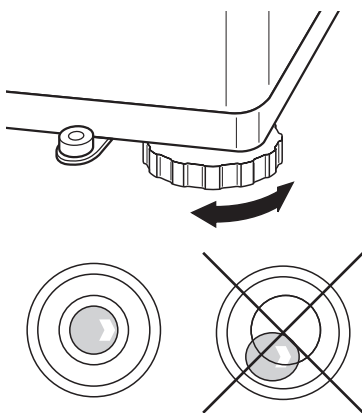

Adjust the scale horizontally by turning the leveling feet, then use the open-end wrench supplied to tighten the locknuts of all the leveling feet so as to prevent unintentional movement.

On certified scales, the weighing platform has a level indicator. The air bubble must lie within the inner circle of the indicator.

Note: The level indicator can be mounted in a different position. Undo the two fastening screws and move the level indicator to one of the positions provided (drilled holes in the weighing platform).

Major changes of geographical location

Each scale is adjusted by the manufacturer for the local gravitational conditions (geo value). If there is a major change of geographical location, this adjustment must be corrected by a service technician. Certified scales must also be recertified in accordance with local national regulations for certification.

1.5 Connecting the power supply

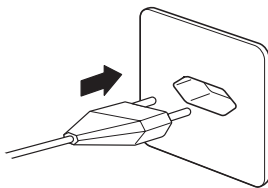

0.000 kg

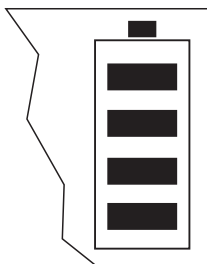

Before connecting the power supply, check that the voltage printed on the back of the scale is the same as the local power supply. If it is not, do not connect the scale, and contact your authorized METTLER TOLEDO representative.

If the voltage is correct, connect the plug on the power cable to the power supply.

After the scale has been connected, it performs a display test. When the display shows zero, the scale is ready for operation. For maximum precision, after installing the scale carry out an adjustment/calibration (Chapter 4.4.1). **Important:** Certified scales must be adjusted by an authorized laboratory. Ask your authorized representative.

Scales which have an **OptionPac with built-in storage battery** can operate under normal conditions for approx. 30 hours disconnected from the power supply (with backlighting turned off and no accessories connected). As soon as the power supply is interrupted, the scale automatically switches over to battery operation. When power is restored, the scale automatically switches back to power supply operation. The battery symbol indicates the current charge status of the storage battery (1 segment = approx. 25% capacity). If the symbol flashes, the storage battery must be recharged (8 hours minimum). If work continues while recharging, it takes longer. The storage battery is protected against overcharging, so the scale can be permanently connected to the power supply without problem.

2 Weighing

This chapter explains how you switch the scale on and off, adjust the zero setting, tare the scale, carry out weighings, and record weighing results.

2.1 Switching on/off and setting to zero

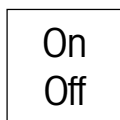

You switch the scale on and off by pressing the «**On/Off**» key.

After it has been switched on, the scale carries out a display test. When the weight display appears, the scale is ready for weighing and is automatically set to zero.

Note: The «→0←» key can be used to set the scale to zero at any time.

2.2 Simple weighing

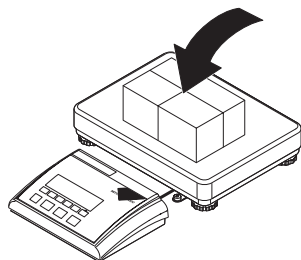

Place the weighing sample on the pan.

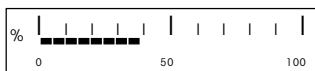

The bar graph in the lower part of the display shows how much of the weighing range is already used and how much is still available (in % of the nominal capacity of the scale).

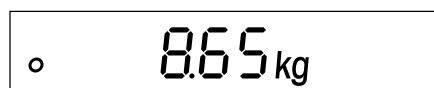

Wait until the stability detector (small ring at left-hand edge of display) goes off and then read the weighing result.

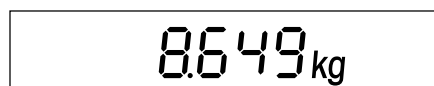
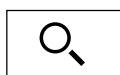

You can use the «**Q**» key in **control mode** to display the weighing result at higher resolution. After a few seconds, the weight display automatically returns to normal.

Note: Control mode is not available if the highest resolution has already been set in the menu (Chapter 4.4.2). On certified scales, in control mode the weight is displayed without a weighing unit.

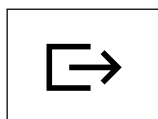

You can use the «**E**» key to transmit the weighing result via the interface to a peripheral device (printer, computer) (see Chapter 5.3 for sample report).

2.3 Weighing with tare

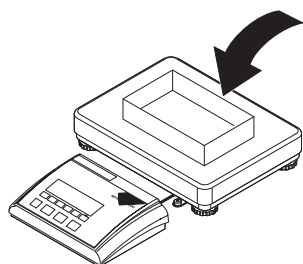

Place the **empty** weighing container or the packaging material on the weighing pan and press the «→T←» key to tare the scale.

0.00 kg ^{NET}

The zero display and the "NET" (net weight) symbol appear. **Note:** If the **automatic tare function** is active (Chapter 4.4.3), you need not press the «→T←» key, since the first weight added is taken to be the tare ("T" flashes in the display until the tare is added).

Place the weighing sample on the weighing pan and ...

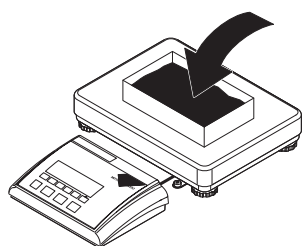

2.46 kg ^{NET}

... read the result (net weight of the weighing sample).



You can use the « BG/Net» key at any time to switch the display between the net and gross weight. After the key is pressed, the display shows the gross weight ("B/G") for a few seconds and then changes back automatically to the net weight ("NET").

2.47 kg ^{B/G}

Note: The tare weight is retained until either a new tare is determined, or the scale is set to zero or switched off.

If the automatic taring function is active, the tare is automatically cleared when weighing is completed and the weighing pan emptied; the scale is then ready for the next taring and weighing.

2.4 Weighing with 2-scale systems

If a second scale is connected, the weighing can be carried out on either the Spider or the second scale.

4.36 kg ^{△△1}

The scale symbol in the upper right corner of the display indicates the currently active scale (△△1 or △△2).

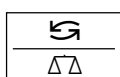

The « △△» key switches between the two scales.

28.55 kg ^{△△2}

All the keys of the Spider terminal act on the currently active scale. Second scales which support MT-SICS can be set to zero and tared from the Spider terminal.

2.5 Dynamic weighing

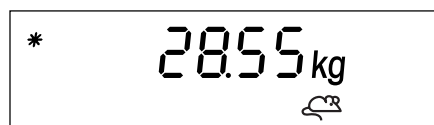

For unstable weighing objects (e.g. animals) the dynamic weighing function with automatic or manual start can be activated (section 4.5.2). If the dynamic weighing function is active, the mouse symbol appears at the bottom edge of the display.

With dynamic weighing the scale measures 56 weighing values in 4 seconds and calculates their mean value.

With dynamic weighing and **automatic start** the measurement begins automatically as soon as there is a change in weight.

With dynamic weighing and **manual start** the measurement is started by touching the «» key.

During dynamic weighing, horizontal segments appear in the display, after which the calculated mean value is displayed. The star symbol at the left-hand edge indicates that the result is a calculated one. To start a new weighing cycle, the scale must be unloaded.

Note: Only activate the dynamic weighing function to weigh unstable goods. In normal operation the standard weighing function yields more accurate results more rapidly.

3 Piece counting

Your scale has a number of powerful piece counting functions which can be activated in the menu (see Chapter 4.5.1). This chapter describes the functions which have been activated at the factory.

3.1 Counting pieces into a container

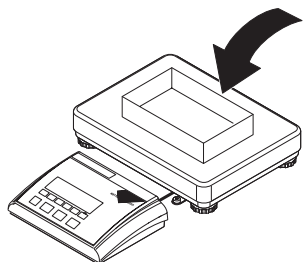

Place the **empty** container on the scale and tare with the «→T←» key.

Note: If the **automatic taring** function is active (Chapter 4.4.3), you need not press the «→T←» key, because the scale registers the tare weight automatically as soon as the container is placed on the weighing pan.

Before your scale can be used for counting parts, it must know the average piece weight (the so-called **reference**). To determine this, you must place a certain number of the pieces to be weighed on the weighing pan. The scale determines their total weight and divides it by the number of pieces (the so-called reference number of pieces). Based on this calculated average piece weight, counting can then be carried out.

Select the reference number of pieces:

– When exactly **10 pieces** have been placed on the pan, press the «**Ref 10**» key .

Ref 10

Ref n

5

100

– If a **different number of pieces** has been placed on the weighing pan, press the «**Ref n**» key and hold it down until the respective number of pieces is displayed above the key. At the factory, piece numbers of 1, 2, 5, 15, 20, 25, 30, 50, 100 and “no” («**Ref n**» key inactive) are provided. The variable reference number of pieces is retained until you change it again.

10^{NET}
Pcs

When the «**Ref 10**» or «**Ref n**» key is released, the scale determines the reference (average piece weight) and then indicates the number of pieces.

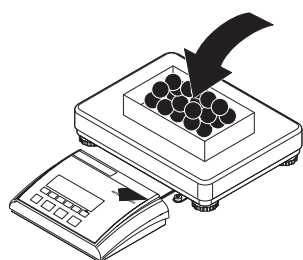

Place more pieces in the container until the desired number is reached.

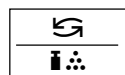

Once a reference has been determined, you can use the «↺ Pcs» key to switch back and forth between the number of pieces and the weight display at any time.

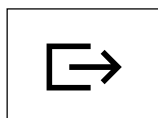

You can use the «E» key to transmit the piece counting result via the interface to a peripheral device (printer, computer) (for sample report see Chapter 5.3).

3.2 Counting pieces out of a container

There are only a few points of difference between counting pieces out of a weighing container and counting them in.

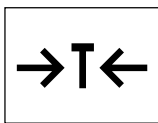

Place the **full** container on the weighing pan and then press the «→T←» key to tare the scale.

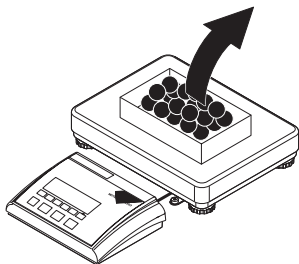

Determine reference:

Remove the reference number of pieces from the weighing container and ...

Ref 10

Ref n

... then press the «**Ref 10**» or «**Ref n**» key to determine the reference, as described in the previous chapter.

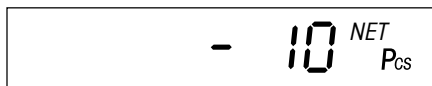

The scale displays the number of pieces removed, preceded by a minus sign.

3.3 Automatic reference optimization

Piece counting with automatic reference optimization gives more accurate results. This function can be switched on and off in the menu (Chapter 4.5.1). Automatic reference optimization is switched on at the factory.



No action is required during operation for automatic reference optimization and it functions both when "Counting in" (Chapter 3.1) and when "Counting out" (Chapter 3.2). The "**Auto Opt**" symbol in the display indicates that automatic reference optimization is switched on.

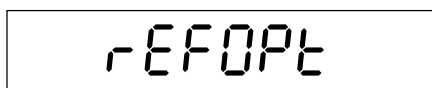

Each time you place additional parts on the scale, it optimizes automatically. You do not have to press a key to perform optimization. At each optimization the message "Ref Opt" appears briefly and the new total number of pieces is then displayed.

Note: At each automatic reference optimization the average piece weight (reference) is re-calculated. Since the additional pieces increase the basis for the calculation, the reference also becomes more accurate. However, automatic optimization only functions if the number of additional pieces placed on the scale is not greater than the number already on the weighing pan.

3.4 Adding mode

Adding mode ensures that the reference number of pieces used for piece counting is not too small, because this could lead to inaccurate results. This function can be switched on and off in the menu (Chapter 4.5.1). Adding mode is switched off at the factory.

Note: Adding mode does not function in two-scale operation!

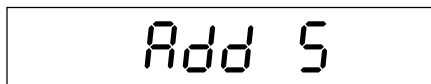

If adding mode is active and the number of pieces placed on the scale is too small to determine the reference correctly, you will be prompted to place more pieces on the scale (e.g. 5 pieces).

Place the prompted number of additional pieces on the weighing pan. Each time a part is added, the scale dynamically shows the number of pieces still missing. As soon as all the additional pieces have been loaded, the scale calculates the reference.

3.5 Piece counting with two-scale systems

The Spider scale can be combined with a second scale, e.g. a floor scale, to count large numbers of pieces. With this system the reference is determined on the Spider scale, while the second scale serves as the counting scale. If the Spider scale is combined with a high-resolution scale (e.g. Viper MonoBloc) this becomes the reference scale and the Spider scale then serves as the counting scale. To set up a two-scale system the second scale has to be connected to an interface on the Spider scale (either the standard or optional RS232C interface, or the optional analog interface). If the second scale is connected via an RS232C interface, the communication parameters on the two scales must be identical (9600 baud, 8 bits, no parity, XOn/XOff protocol). The operating mode for the interface of the second scale must be set to "Dialog" or "Host" depending on the model of the second scale. Information for configuring the interfaces of the Spider scale is contained in Chapter 4.7. Information for setting the interface parameters of the second scale will be found in the respective operating instructions.

You can specify in the menu of the Spider scale whether the second scale should be used as the reference or counting scale (Chapter 4.7.1). The second scale is normally used as the reference scale, whereas piece counting takes place on the Spider.

The basic procedure for piece counting is the same as with a single-scale system, except for the following differences:



The « $\Delta\Delta$ » key can be used at any time to switch between the two scales.

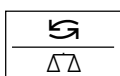

The scale symbol at the top right of the display indicates the active scale:

$\Delta\Delta$ 1 = Spider scale

$\Delta\Delta$ 2 = second scale



The operating steps for piece counting always refer to the active scale.

With the second scale active, the « $\rightarrow 0 \leftarrow$ » and « $\rightarrow T \leftarrow$ » keys can be used for zero setting and taring (second scales connected via an RS232C interface must support the MT-SICS command set).

4 The menu

The menu can be used to change the settings for the scale and to activate functions, thereby allowing the scale to be adapted to individual weighing needs.

Important: To avoid incorrect operation of the scale in normal use, the menu can be protected with a password. The scale differentiates between a user and a supervisor. When the scale leaves the factory, the entire menu can be accessed by both user and supervisor. **We therefore recommend you to define your own supervisor password as soon as you set up the scale (Chapter 4.6.2).** This limits access by the user to a small number of menu items (calibration, and settings for energy-saving mode and backlighting).

4.1 Overview and operation

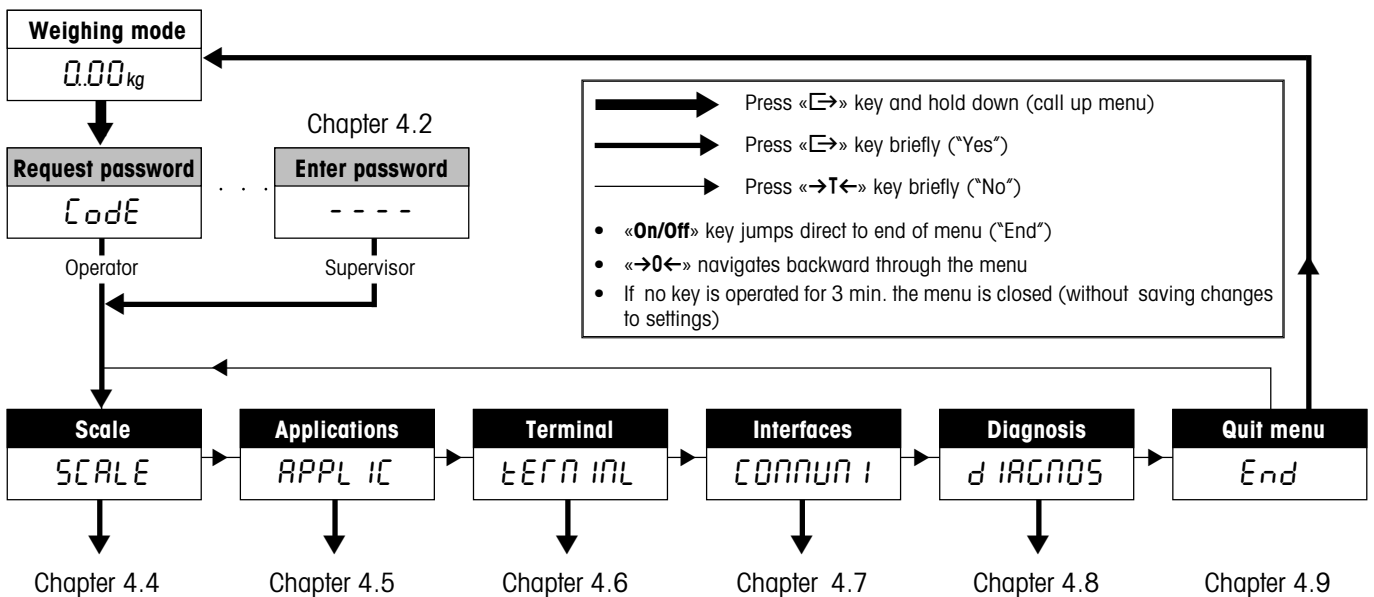

Chapter 4.3 contains a complete overview of the menu and all the possible settings.

4.2 Calling up the menu and entering the password

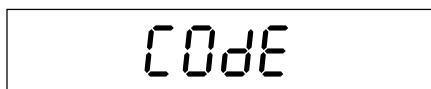

Press the « \rightarrow » key and hold it down until the prompt to enter the password appears.

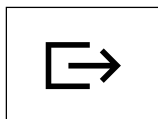

User: No password required, just press the « \rightarrow » key.

Supervisor: Enter password (sequence of keystrokes) **immediately** and confirm with the « \rightarrow » key, otherwise after a few seconds the scale returns to weighing mode. If an incorrect password is entered, the menu cannot be called up.

Note: When the scale leaves the factory no supervisor password is defined, so when the password is requested, just press the « \rightarrow » key.

If the password entered is correct, the first block of the menu appears ("SCALE").

4.3 Menu overview

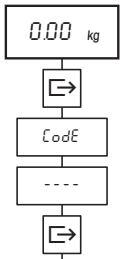

Operation

- Press « \rightarrow » key ("Yes")
- Press « \rightarrow T« \leftarrow » key ("No")

«On/Off» key jumps direct to the end of the menu ("End")

« \rightarrow 0« \leftarrow » navigates backward through the menu

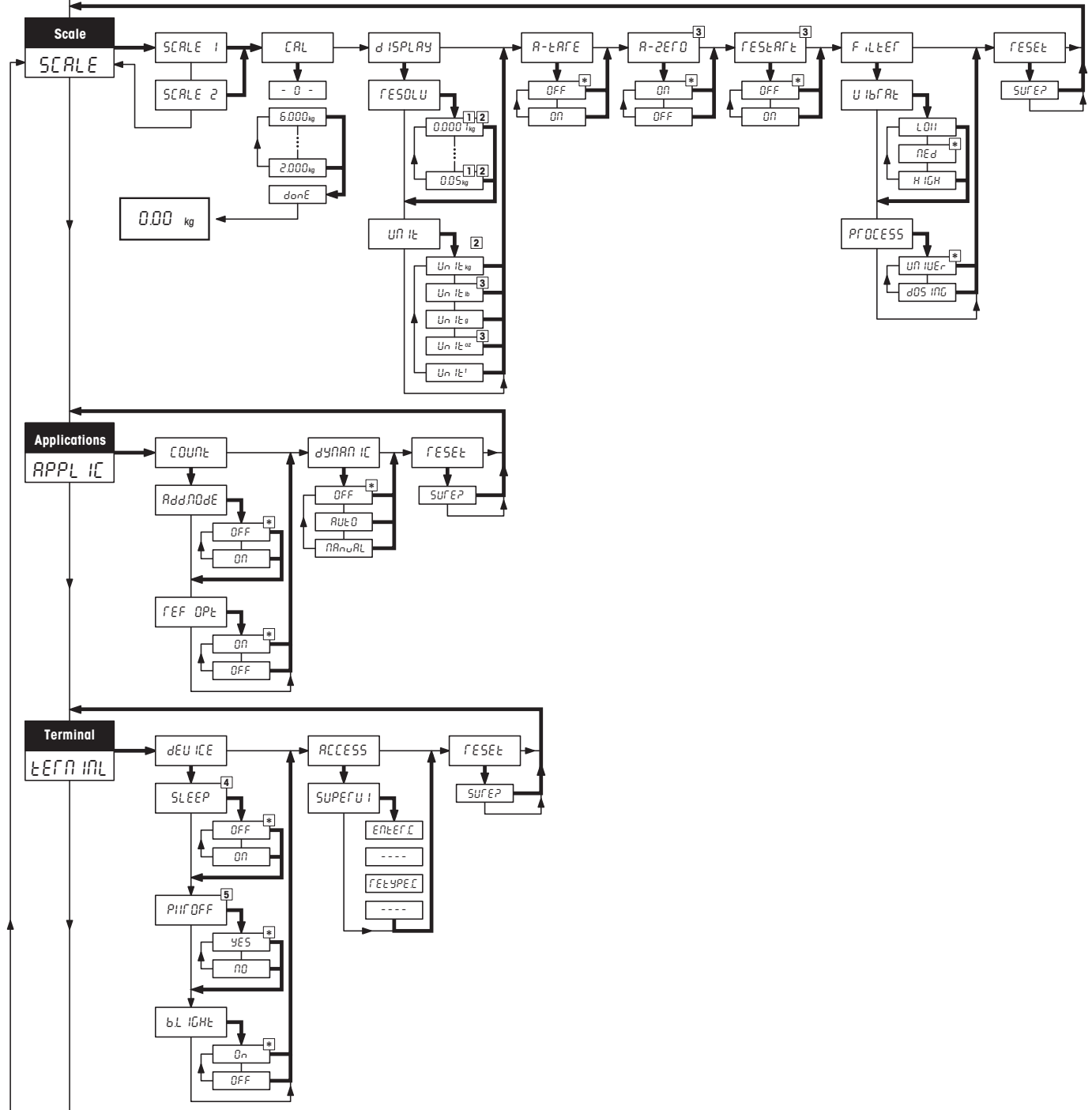

Menu (continued)

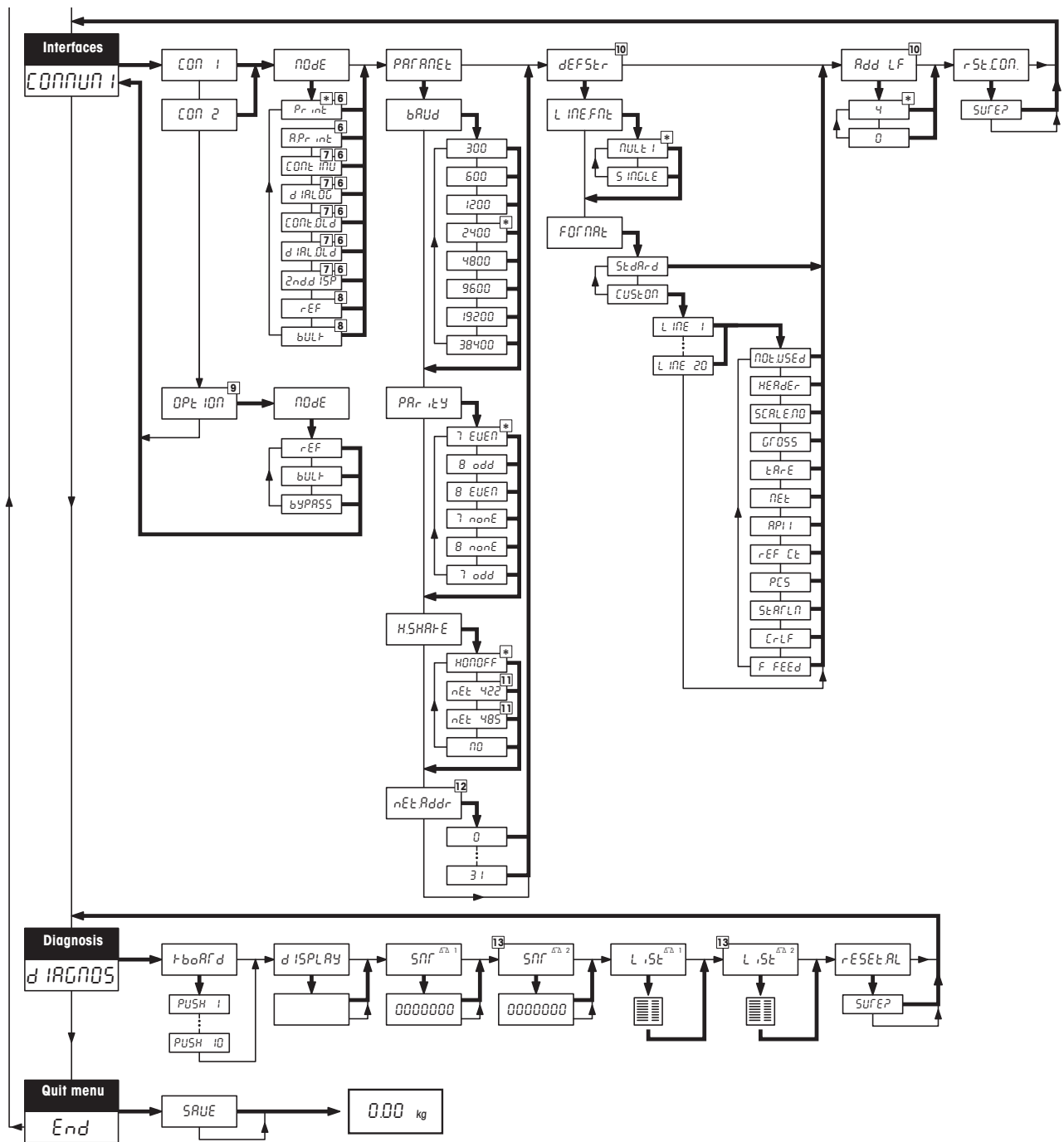

* Factory setting

- | | |
|---|--|
| <ul style="list-style-type: none"> 1) Available settings depend on model. 2) Factory setting depends on model. 3) Not available on certified scales. 4) Not available on scales with storage battery. 5) Not available on scales driven from power supply (without storage battery). 6) Not available for analog option. 7) Only available for COM2 if analog option is not installed or is deactivated. | <ul style="list-style-type: none"> 8) For second scale connected to a COM interface, only available if analog option is not installed or is deactivated. 9) Only available for analog option. 10) Only available for "Print" and "AutoPrint" operating modes. 11) Not available for COM2. 12) Only available if "Handshake" is set to "Net 422" or "Net 485". 13) Only available if analog option is installed and active. |
|---|--|

4.4 Scale settings (SCALE)

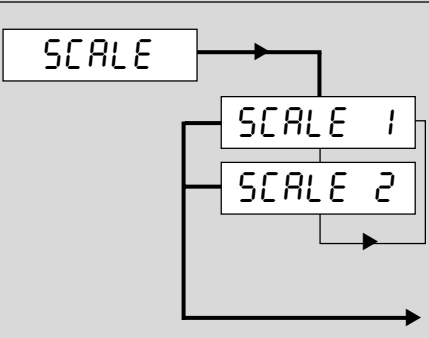
Display	Explanation
 <pre> graph TD SCALE[SCALE] --> SCALE1[SCALE 1] SCALE --> SCALE2[SCALE 2] SCALE --> FS[Functions and settings] </pre>	<p>Scale settings:</p> <p>Settings and functions for Spider scale</p> <p>Settings and functions for second scale</p> <p>Note: The "SCALE 1/SCALE 2" selection only appears if the analog option is installed.</p> <p>Functions and settings:</p> <ul style="list-style-type: none"> Adjust/calibrate scale → Chapter 4.4.1 Display accuracy and weighing unit → Chapter 4.4.2 Automatic taring → Chapter 4.4.3 Automatic zero point correction → Chapter 4.4.4 Automatic storage of tare and zero values → Chapter 4.4.5 Adaptation to environmental conditions/weighing mode → Chapter 4.4.6 Reset scale settings to factory settings → Chapter 4.4.7

4.4.1 Adjust/calibrate scale (SCALE → Cal)

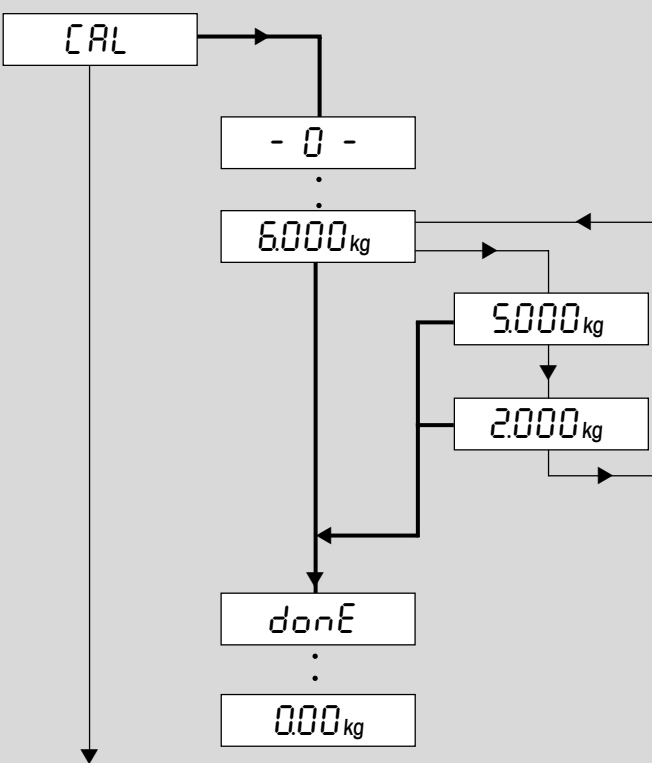
Display	Explanation
 <pre> graph TD CAL[CAL] --> Z0[- 0 -] Z0 --> W6[6000 kg] W6 --> W5[5000 kg] W6 --> W2[2000 kg] W5 --> W2 W2 --> Done[done] Done --> W0[0.00 kg] </pre>	<p>Calibrating/adjusting the scale (weighing pan must be empty). Not available on certified scales!</p> <p>Scale determines the zero point, display flashes (no confirmation required).</p> <p>Scale prompts for calibration weight.</p> <p>Change calibration weight if desired (available values depend on scale).</p> <p>Place selected weight on pan and confirm.</p> <p>Calibration is successfully completed....</p> <p>... scale returns automatically to weighing mode.</p>

4.4.2 Display accuracy and weighing unit (SCALE → Display)

Display	Explanation
<pre> graph TD DISPLAY[d ISPLAY] --> RESOLU[RESOLU] DISPLAY --> UNIT[UNIT] RESOLU --> R1["0000 1kg"] RESOLU --> R2["005 kg"] UNIT --> U1[kg] UNIT --> U2[oz] UNIT --> U3[lb] UNIT --> U4[t] UNIT --> U5[g] </pre>	<p>Block can only be accessed by supervisor.</p> <p>Display accuracy (resolution): Setting values and factory setting depend on model. On certified scales, resolutions which deviate from the scale definition are displayed without the weighing unit and with a star symbol (weighing result does not correspond to calibrated resolution). On dual-range balances resolutions marked with "l<->l 1/2" are spread over two weighing ranges (e.g. B 2 x 3,000d).</p> <p>Weighing unit (factory setting according to type plate): Kilogram Ounce (not available on certified scales) Pound (not available on certified scales) Ton (metric ton) Gram</p>

4.4.3 Automatic taring (SCALE → A-Tare)

Display	Explanation
<pre> graph TD ATARE[A-TARE] --> OFF[OFF] ATARE --> ON[On] </pre>	<p>Block can only be accessed by supervisor.</p> <p>Automatic taring function switched off (factory setting).</p> <p>Automatic taring function switched on. The first weight placed on the scale is interpreted as the tare.</p>

4.4.4 Automatic zero point correction (SCALE → A-Zero)

Display	Explanation
<pre> graph TD AZERO[A-ZERO] --> ON[On] AZERO --> OFF[OFF] </pre>	<p>Can only be accessed by supervisor. Not available on certified scales.</p> <p>Auto zero switched on (factory setting).</p> <p>Auto zero switched off (display can be set to zero manually with the «→0←» key).</p>

4.4.5 Automatic save of tare and zero values (SCALE → Restart)

Display	Explanation
	<p>Block can only be accessed by supervisor. Not available on certified scales.</p> <p>Automatic save switched off (factory setting).</p> <p>Automatic save switched on, last tare and zero values are saved and are available again after a power outage or switching off.</p>

4.4.6 Adaptation to environmental conditions and weighing mode (SCALE → Filter)

Display	Explanation
	<p>Block can only be accessed by supervisor.</p> <p>Environmental conditions (vibration adapter):</p> <p>Normal environmental conditions ("medium"): scale operates at medium speed (factory setting).</p> <p>Unstable environment ("high"): scale operates more slowly but is less sensitive to external influences.</p> <p>Very stable and stable environment ("low"): scale operates very quickly but is more sensitive to external influences.</p> <p>Weighing mode (weighing process adapter):</p> <p>Universal setting for all weighing types and normal weighing goods (factory setting).</p> <p>Dispensing liquids or powdery substances.</p>

4.4.7 Reset scale settings to factory settings (SCALE → Reset)

Display	Explanation
	<p>Resets all scale settings to the factory settings (applies only to selected scale, "SCALE 1" or "SCALE 2"). This block can only be accessed by the supervisor.</p> <p>Confirm resetting or cancel.</p>

4.5 Application settings (APPLICATION)

Display	Explanation
	<p>Application settings: can only be accessed by supervisor!</p> <p>COUNT: Settings for piece counting → Chapter 4.5.1</p> <p>DYNAMIC: Activate dynamic weighing function → Chapter 4.5.2</p> <p>RESET: Reset application settings to factory settings → Chapter 4.5.3</p>

4.5.1 Settings for piece counting (APPLICATION → Count)

Display	Explanation
	<p>Adding mode (does not function in two-scale operation): Adding mode switched off (factory setting).</p> <p>Adding mode switched on (when piece counting, ensures that the reference quantity used is not too small, see Chapter 3.5).</p> <p>Reference optimization: Reference optimization switched on (factory setting), increases piece counting accuracy (see Chapter 3.4).</p> <p>Reference optimization switched off.</p>

4.5.2 Activating the dynamic weighing function (APPLICATION → Dynamic)

Display	Explanation
	<p>This function facilitates weighing unstable weighing goods (e.g. animals).</p> <p>Dynamic weighing function switched off (factory setting).</p> <p>Dynamic weighing function with automatic start switched on (for notes on use, see Chapter 2.5).</p> <p>Dynamic weighing function with manual start switched on (for notes on use, see Chapter 2.5).</p>

4.5.3 Reset application settings to factory settings (*APPLICATION* → *Reset*)

Display	Explanation
<pre> graph TD RESEt[RESEt] --> SUREP[SUREP] SUREP --> RESEt SUREP --> Exit[] style Exit fill:none,stroke:none </pre>	<p>Resets all application settings to the factory settings.</p> <p>Confirm resetting or cancel.</p>

4.6 Terminal settings (*TERMINAL*)

Display	Explanation
<pre> graph TD TERMINL[TERMINL] --> DEVICE[DEVICE] DEVICE --> ACCESS[ACCESS] ACCESS --> RESEt[RESEt] RESEt --> TERMINL </pre>	<p>Only the "Device" block is available to the user!</p> <p>Standby, energy-saving mode, and display backlighting → Chapter 4.6.1</p> <p>Password for menu access → Chapter 4.6.2</p> <p>Reset terminal settings to factory settings → Chapter 4.6.3</p>

4.6.1 Standby, energy-saving mode, and display backlighting (*TERMINAL* → *Device*)

Display	Explanation
<pre> graph TD DEVICE[DEVICE] --> SLEEP[SLEEP] SLEEP --> OFF[OFF] OFF --> ON[ON] ON --> SLEEP SLEEP --> PIIPOFF[PIIPOFF] PIIPOFF --> YES[YES] YES --> PIIPOFF PIIPOFF --> NO[NO] NO --> PIIPOFF PIIPOFF --> bLIGHT[bL IGHT] bLIGHT --> On[On] On --> OFF2[OFF] OFF2 --> bLIGHT bLIGHT --> Exit[] style Exit fill:none,stroke:none </pre>	<p>Can be accessed by user!</p> <p>Standby (only for scales operated from power supply):</p> <p>Standby switched off, display permanently activated (factory setting).</p> <p>Standby switched on. If there is no activity for 3 minutes, the display and backlighting are deactivated ("SLEEP"). They are reactivated when a key is pressed or the weight is changed.</p> <p>Energy saving mode (for battery-operated scales only):</p> <p>Energy saving mode active. If there is no activity for 3 minutes, the scale is switched off (factory setting).</p> <p>Energy saving mode inactive, scale does not switch off automatically.</p> <p>Display backlighting:</p> <p>Backlighting switched on (factory setting). Battery-operated scales: switches off automatically after 5 seconds.</p> <p>Backlighting switched off.</p>

4.6.2 Password for menu access (TERMINAL -> Access)

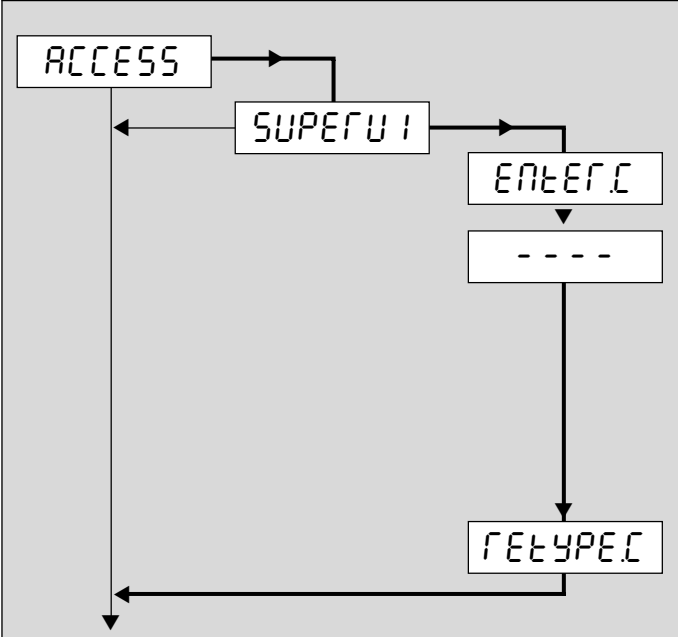
Display	Explanation
 <pre> graph TD ACCESS[ACCESS] --> SUPERUI[SUPERUI] SUPERUI --> ENTERC[ENTERC] ENTERC --> DASH[----] DASH --> RETYPEC[RETYPEC] RETYPEC --> ACCESS </pre>	<p>Can only be accessed by supervisor!</p> <p>Define supervisor password:</p> <p>Prompt to enter password.</p> <p>Enter password (min. 1, max. 4 characters) and confirm with «↵».</p> <p>Important: The «↵» key cannot be used as part of the password because it terminates the input! If «↵» is pressed immediately after the entry prompt, the existing password is cleared. The user then has complete access to the menu again. The «→0←» key can only be used in combination with at least one other key!</p> <p>Re-enter the password and confirm with «↵».</p>

4.6.3 Reset terminal settings to factory settings (TERMINAL -> Reset)

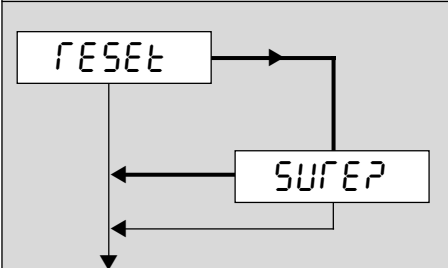
Display	Explanation
 <pre> graph TD RESET[RESET] --> SUPER[SUPER] SUPER --> RESET </pre>	<p>Resets all terminal settings to the factory settings. Only the settings in the "Device" block are reset, not the password for menu access.</p> <p>Confirm resetting or cancel.</p>

4.7 Configure interfaces (*COMMUNICATION*)

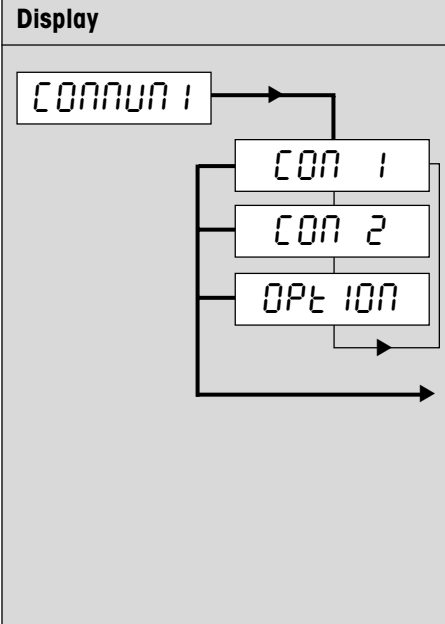
Display	Explanation
 <p>The screenshot shows the 'COMMUN 1' menu. Below the title, there are three options: 'CON 1', 'CON 2', and 'OPT ION'. Arrows indicate that 'CON 1' and 'CON 2' lead to a common point, and 'OPT ION' leads to another point. A vertical arrow on the left indicates the menu flow.</p>	<p>Configures the scale interfaces: can only be accessed by supervisor!</p> <p>Standard interface COM1 (RS232C or RS422/485).</p> <p>Optional interface COM2 (RS232C).</p> <p>Analog option (only if analog option installed).</p> <p>Settings:</p> <ul style="list-style-type: none"> Operating mode of interface → Chapter 4.7.1 Communication parameters → Chapter 4.7.2 Settings for printed reports → Chapter 4.7.3 Insert line feeds into printed reports → Chapter 4.7.4 Reset interface settings to factory settings → Chapter 4.7.5

4.7.1 Operating mode of interface (*COMMUNICATION* → *Mode*)

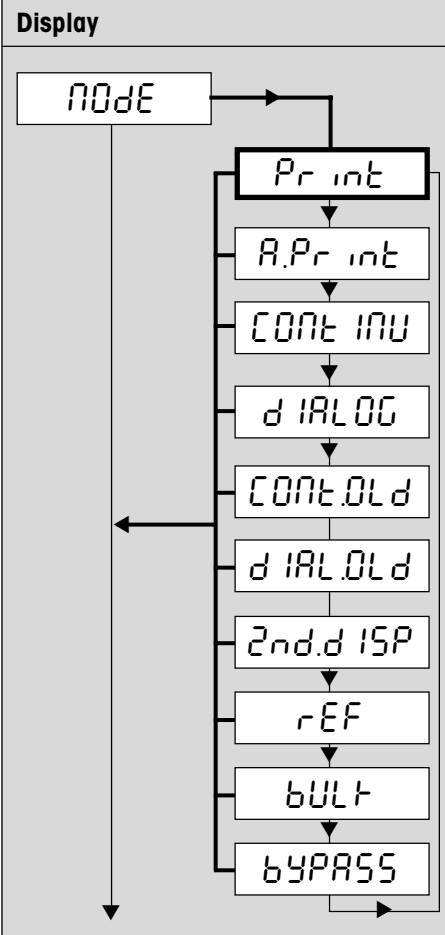
Display	Explanation
 <p>The screenshot shows the 'MODE' menu. Below the title, there are ten options: 'Print', 'A.Print', 'CONTINU', 'dIALOG', 'CONTOLD', 'dIALOGd', '2nd.dISP', 'rEF', 'BULK', and 'BYPASS'. Arrows indicate the flow between options. A vertical arrow on the left indicates the menu flow.</p>	<p>Manual data output on printer («E» key). Factory setting.</p> <p>Automatic output of stable results on printer (for series weighings).</p> <p>Continuous output of all weight values via the interface. Not available for COM2 if analog option active!</p> <p>Bidirectional communication using MT-SICS commands (to control scale from a PC). Not available for COM2 if analog option active!</p> <p>Same as "Continuous" (see above), but with 2 fixed blanks before the unit (compatible with Spider 1/2/3).</p> <p>Same as "Dialog" (see above), but scale sends 2 fixed blanks before the unit (compatible with Spider 1/2/3).</p> <p>Connects a second display. Not available for COM2 if analog option active!</p> <p>Second scale serves as reference scale.</p> <p>Second scale serves as counting scale.</p> <p>Deactivates the analog option (if present). If the analog option is not deactivated, the "Ref" and "Bulk" settings are no longer available for COM1, and only the "Print" and "A. Print" operating modes are available for COM2!</p>

4.7.2 Communication parameters (COMMUNICATION → Parameters)

Display	Explanation
	<p>Not available for analog option. Parameters on the connected device (printer, PC, second display) must be set to the same values:</p> <p>Interface data transmission rate:</p> <p>300 baud – 38400 baud. Factory setting = 2400 baud.</p> <p>Number of data bits and parity:</p> <p>7 data bits, even parity (factory setting)</p> <p>8 data bits, odd parity</p> <p>8 data bits, even parity</p> <p>7 data bits, no parity</p> <p>8 data bits, no parity</p> <p>7 data bits, odd parity</p> <p>Factory setting depends on operating mode of interface.</p> <p>Transmission protocol:</p> <p>Xon/Xoff protocol (factory setting).</p> <p>Network operation according to RS422 standard via optional RS422/485 interface (COM1). Not available for COM2.</p> <p>Network operation according to RS485 standard via optional RS422/485 interface (COM1). Not available for COM2.</p> <p>No communication protocol.</p> <p>Network address (only available for "Net 422" and "Net 485", see Chapter 5.1.4 for notes on network operation).</p> <p>Available network addresses 0 – 31.</p>

4.7.3 Settings for printed reports (*COMMUNICATION* → *Definition String*)

Display	Explanation
<pre> graph TD dEFStR[dEFStR] --> L_INE_FNt[L INE FNt] L_INE_FNt --> MULTI[MULTI] L_INE_FNt --> SINGLE[SINGLE] MULTI --> FORMAt[FORMAt] SINGLE --> FORMAt FORMAt --> StdARd[StdARd] FORMAt --> CUStON[CUStON] StdARd --> CUStON CUStON --> L_INE_1[L INE 1] L_INE_1 --> L_INE_20[L INE 20] L_INE_20 --> NOT_USEd[NOT USEd] NOT_USEd --> HEAdEr[HEAdEr] NOT_USEd --> SCALe_ND[SCALe.ND] NOT_USEd --> GRoSS[GRoSS] NOT_USEd --> tArE[tArE] NOT_USEd --> NEt[NEt] NOT_USEd --> RPt[RPt] NOT_USEd --> rEF_Ct[rEF Ct] NOT_USEd --> PCS[PCS] NOT_USEd --> StARFLn[StARFLn] NOT_USEd --> CrLF[CrLF] NOT_USEd --> F_FEEd[F FEEd] </pre>	<p>Only available for "Print" and "A.Print" operating modes (Chapter 4.7.1).</p> <p>Report formatting:</p> <p>Each value on the report is printed on a separate line (factory setting).</p> <p>Several values are printed on one line.</p> <p>Data to be reported:</p> <p>Standard report (factory setting) containing report header, gross, net, and tare weight (if present). For piece counting, also reference piece weight, number of reference pieces, and result of piece counting.</p> <p>Defines customized report: Defines the values to be reported on up to 20 report lines.</p> <p>The following settings are available for each line:</p> <p>Report line not used (factory setting).</p> <p>Report header (Chapter 5.1.3).</p> <p>Scale number (for two-scale systems only)</p> <p>Gross weight</p> <p>Tare weight</p> <p>Net weight</p> <p>Average piece weight</p> <p>Reference quantity</p> <p>Piece counting result ("Pieces")</p> <p>Line of stars ("Starline")</p> <p>Line feed (for empty line)</p> <p>Form feed for label printer.</p>

4.7.4 Inserting line feeds into the report (*COMMUNICATION* → *Add Line Feed*)

Display	Explanation
	<p>Inserts additional line feeds at the end of the report. On printers with tear-off edge (e.g. "Sprinter" printer) the paper can be fed forward far enough for the report to be torn off. Only available for "Print" and "A.Print" operating modes (Chapter 4.7.1):</p> <p>4 additional line feeds at end of report (factory setting).</p> <p>No additional line feeds at end of report.</p>

4.7.5 Reset interface settings to factory settings (*COMMUNICATION* → *Reset*)

Display	Explanation
	<p>Resets all settings in the "COMMUNICATION" menu block to the factory settings. Resetting only affects the selected interface (COM1 or COM2). Not available for analog option.</p> <p>Confirms or cancels resetting. After confirmation the scale uses the factory settings again.</p>

4.8 Diagnosis and printout of menu settings (*DIAGNOSTICS*)

Display	Explanation
	<p>Can only be accessed by supervisor!</p> <p>Keyboard → Check keyboard → Chapter 4.8.1</p> <p>DISPLAY → Check display → Chapter 4.8.2</p> <p>SNR → Display serial number → Chapter 4.8.3</p> <p>List → Print menu settings → Chapter 4.8.4</p> <p>RESET.AL → Reset all menu settings to factory settings → Chapter 4.8.5</p> <p>Note: If a second weighing platform is connected via the analog option, separate menu blocks are displayed for its serial number ("SNR ΔΔ2") and to print out its menu settings ("List ΔΔ2").</p>

4.8.1 Checking the keyboard (*DIAGNOSTICS* → *Keyboard*)

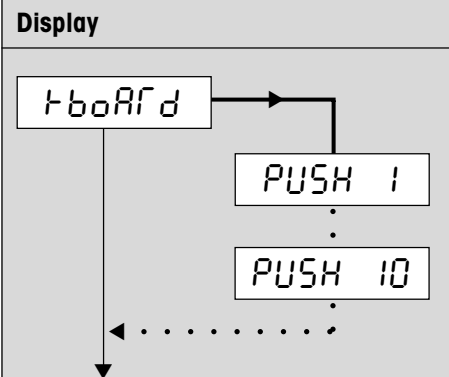
Display	Explanation												
	<p>Press all 10 keys in sequence. If a key is functioning, the scale jumps to the next key. The keys are numbered as follows:</p> <table border="1" style="margin-left: auto; margin-right: auto;"> <tr> <td>5</td><td>6</td><td>7</td><td>8</td><td>9</td><td>10</td> </tr> <tr> <td>1</td><td>2</td><td>3</td><td>4</td><td></td><td></td> </tr> </table>	5	6	7	8	9	10	1	2	3	4		
5	6	7	8	9	10								
1	2	3	4										

4.8.2 Checking the display (*DIAGNOSTICS* → *Display*)

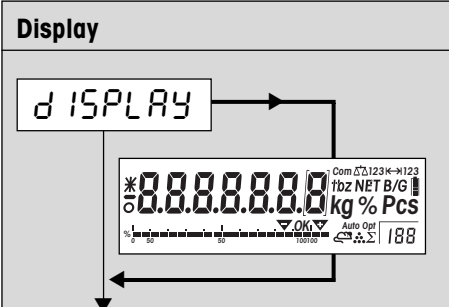
Display	Explanation
	<p>The scale displays the functioning segments. Check whether all segments are visible (compare with illustration on first inside page of these instructions).</p>

4.8.3 Display serial number (*DIAGNOSTICS* → *SNR*)

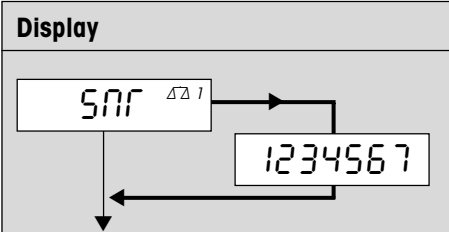
Display	Explanation
	<p>Serial number of Spider scale (max. 7 characters). If a second weighing platform is connected to the analog option, an additional menu block ("SNR ΔΔ2") appears with its serial number.</p>

4.8.4 Printing the menu settings (*DIAGNOSTICS* → *List*)

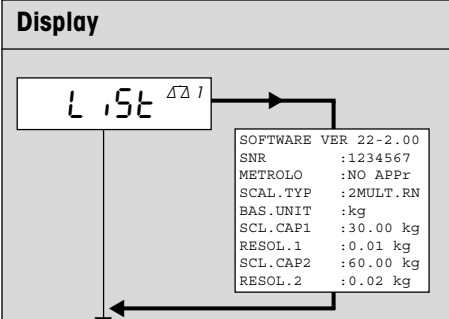
Display	Explanation
 <pre> SOFTWARE VER 22-2.00 SNR :1234567 METROLO :NO APPr SCAL.TYP :2MULT.RN BAS.UNIT :kg SCL.CAP1 :30.00 kg RESOL.1 :0.01 kg SCL.CAP2 :60.00 kg RESOL.2 :0.02 kg </pre>	<p>Menu settings for the Spider scale are output on a printer (see sample printout in Chapter 5.3). If a second weighing platform is connected to the analog option, an additional menu block ("List ΔΔ2") appears for printing the settings of the second scale.</p>

4.8.5 Reset all menu settings to the factory settings (*DIAGNOSTICS* → *Reset All*)

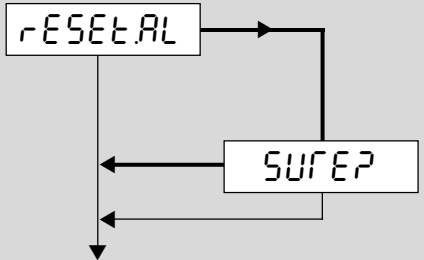
Display	Explanation
	<p>Resets all menu settings to the factory settings. Caution: All the individual settings are lost except for the supervisor password ("TERMINAL" menu block), the calibration data and the settings in the "COMMUNICATION" block!</p> <p>Confirm resetting or cancel.</p>

4.9 Saving the settings and quitting the menu (*End*)

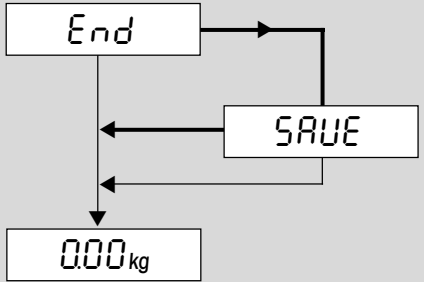
Display	Explanation
	<p>You can go directly to this menu block from any point in the menu by using the «On/Off» key!</p> <p>Save the changed settings or cancel.</p>

5 Additional important information

In this chapter you will find information about the interface commands, error messages, and cleaning your scale.

5.1 SICS interface commands

The Spider scale supports the **METTLER TOLEDO Standard Interface Command Set (MT-SICS)**. You can use MT-SICS commands to configure, interrogate, and operate the scale from a PC via the RS232C or optional RS422/485 interface.

5.1.1 Preconditions for communication between scale and PC

- The scale must be connected to the RS232C interface of a PC by a suitable cable (Chapter 6.6).
- The interface of the scale must be set to "Dialog" mode (Chapter 4.7.1).
- The PC must have a terminal program (e.g. "Hyper Terminal") installed on it.
- The communication parameters (data transmission rate, bits, and parity) in the terminal program must be set to the same values as on the scale (Chapter 4.7.2).

5.1.2 SICS commands supported by the scale

- All **SICS Level 0** ("I0", "I1", "I2", "I3", "I4", "S", "SI", "SIR", "Z", "ZI", "@") and **SICS Level 1** ("D", "DW", "K", "SR", "T", "TA", "TAC", "TI") commands. The additional "SFIR" command corresponds to the SICS Level 0 "SIR" command but transmits a greater number of data records per unit of time (while doing so, the display of the Spider scale is no longer active).
- The following commands from **SICS Level 2R Standard** are implemented: "SU", "SIU", "SIRU" and "SRU".
- The "PW" command from **SICS Level 3R Standard** is supported.
- Special command "P130" for price display in auxiliary display (for details refer to document no. 21300758).
- SQC14 command "XD12" switches operating mode of interface between "Print" and "Dialog".

The "I0" command can be used to inquire the supported commands.

You will find detailed information about the interface commands in the "**MT SICS Reference Manual**" (ME-705184).

Besides the standard commands, there are also **scale-specific SICS commands** which support specific characteristics of the product. These commands are not listed in the "MT SICS Reference Manual" but in the documentation of the specific scale. Your Spider scale currently supports only one scale-specific command for defining the report header.

5.1.3 Scale-specific SICS command for defining the report header

The report header can contain up to 5 lines each with a maximum of 24 characters (see sample report in Chapter 5.3).

The command for defining the report header is **I31_x**. Example:

```
I31_1_"Mettler-Toledo GmbH" <CR><LF>
I31_2_"Heuwinkelstrasse" <CR><LF>
I31_3_"CH-8606 Naenikon" <CR><LF>
I31_4_"Telephone 01 944 22 11" <CR><LF>
I31_5_"Internet www.mt.com" <CR><LF>
```

- Each SICS command line must be terminated with **<CR><LF>**. The command is executed immediately. To make corrections, re-enter the entire line.
- "_" represents a blank. The quotation marks must also be entered. They indicate to the scale that text is being input.
- To insert blank lines, input a blank instead of text.
- To inquire line: **I31_x <CR><LF>**; delete line: **I31_x_"" <CR><LF>** (x = line number).
- Important: The "Header" setting must be activated for the report header to be printed (Chapter 4.7.3).

5.1.4 Network operation via the optional RS422/485 interface

You can use the optional RS422/485 interface to network up to 32 scales. In network operation the scale must be addressed by the host computer before commands can be transmitted and weighing results received. Addressing is done with the control character <ESC> (hex. 1B) followed by the address (in the range from hex. 30... 3F). Following this, the desired SICS command is transmitted and terminated with <CR> (hex. 0D) and <LF> (hex. 0A). This transfers control of the bus to the scale, which then sends its address to the host as confirmation. After that, the scale sends the answer to the command, followed by <CRLF>. By doing this it returns control of the bus to the host.

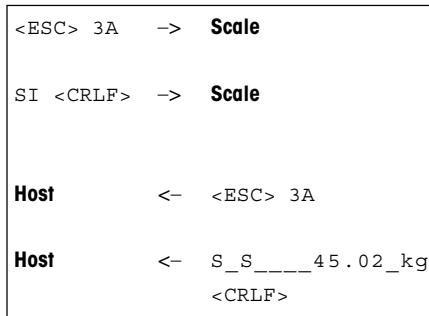

Example: The host addresses the scale with hex address 3A.

The host transmits command (e.g. "SI"). The command is terminated with <CRLF> and control of the bus is transferred to the scale. Note: <ESC> deletes a command already issued.

The scale confirms receipt of the command by sending its address (3A) to the host.

The scale transmits the answer to the command received from the host and with <CRLF> returns control of the bus to the host.

5.2 Warning and error messages

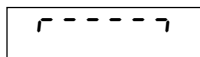

Overload: Reduce the load on the scale or reduce the preload.

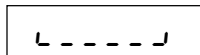

Underload: Place the weighing pan on the scale and ensure it can move freely.

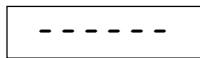

Result not stable: Always appears when not stable (when zeroing, taring, etc.). If the scale still does not become stable after a long time, check the environmental conditions. If necessary, change the setting of the vibration adapter (Chapter 4.4.6) or use the dynamic weighing function (Chapter 2.5/4.5.2).

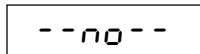

Function not allowed: The requested function cannot be executed because it is not allowed at the time of the request.

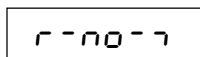

Zeroing not possible: Make sure that zeroing is being performed in the allowed range and not with overload or underload.

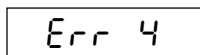
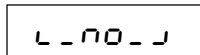

Reference weight too low: The weight on the pan is too low to use as a valid reference for piece counting. Place a larger number of reference pieces on the weighing pan.

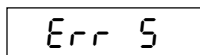

No valid value from reference scale: Only occurs when piece counting on a 2-scale system. Check cable connecting the scales and check interface settings.

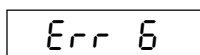

Not calibrated/adjusted: Disconnect the power supply plug and reconnect it (or if the scale is battery-operated, switch it off and then on again). If the message appears again, calibrate/adjust scale (Chapter 4.4.1). If message still appears, contact your authorized METTLER TOLEDO representative.

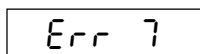

Reference piece weight too low: When determining the reference, the resulting weight of a single piece is below the allowable limit. Piece counting is not possible for such pieces.

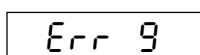

Unstable weight value when determining reference: When determining the reference for piece counting, the weight value did not become stable and the scale cannot determine the reference piece weight. Check the environmental conditions. If necessary, change the setting of the vibration adapter (Chapter 4.4.6).

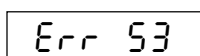

EAROM checksum error: Disconnect the power supply plug and reconnect it (or if the scale is battery-operated, switch the scale off and then on again). If the message re-appears, contact your authorized METTLER TOLEDO representative.

5.3 Sample reports

Weighing with tare

G	4.876 kg
T	0.223 kg
N	4.653 kg

G	=	gross weight
N	=	net weight
T	=	tare
Dyn WT	=	dynamically determined weight
SCALE 1	=	scale (only on two-scale systems)
PIECE WT	=	average piece weight (piece counting)
REF PCS	=	reference piece weight (piece counting)
QUANTITY	=	number of pieces (result of piece counting)

Dynamic weighing

Dyn WT	43.52 kg
T	3.78 kg

Piece counting

SCALE: 1	
G	4.876 kg
T	0.223 kg
N	4.653 kg

PIECE WT	48.468 g
REF PCS	10

QUANTITY	96 PCS
----------	--------

Printout with report header

Mettler-Toledo GmbH
Heuwinkelstrasse
CH-8606 Naenikon
Telefon 01/944 22 11
Internet www.mt.com

G	4.876 kg
T	0.223 kg
N	4.653 kg

Printout of scale settings (°List°, Chapter 4.8.4)

```
SOFTWARE VER 22-2.00
SNR          :1234567
METROLO     :NO APPr
SCAL.TYP    :2MULT.RN
BAS.UNIT    :kg
SCL.CAP1    :30.00 kg
RESOL.1     :0.01 kg
SCL.CAP2    :60.00 kg
RESOL.2     :0.02 kg
GEO         :18
DISPLAY
RESOLU     :0.01 kg
UNIT       :kg
A-TARE     :OFF
A-ZERO     :ON
RESTART    :OFF
VIBRAT     :MID
PROCESS    :UNIVER
ADD.MODE   :OFF
REF OPT    :ON
DYNAMIC    :OFF
SLEEP     :ON
B.LIGHT   :ON
```

```
RS232
MODE      1:Print
BAUD      1:2400
PARITY    1:7 EVEN
H.SHAKE   1:XONXOFF
LINE.FMT  1:MULTI
FORMAT    1:StdArd
ADD LF    1:4
```

```
MODE      2:Print
BAUD      2:2400
PARITY    2:7 EVEN
H.SHAKE   2:XONXOFF
LINE.FMT  2:MULTI
FORMAT    2:StdArd
ADD LF    2:4
```

```
OPTION
MODE      :rEF
```

5.4 Cleaning instructions



Before you start to clean your scale, disconnect it from the power supply!

Use a moist cloth (no acids, caustics, or strong solvents).

Do not use abrasive cleaning agents, they can scratch the display.

Do not clean the scale with a high-pressure cleaner or under running water.

If heavily soiled, remove the weighing pan, protective cover (if present), and leveling feet, and clean them separately.

Never use a rigid object to clean under the load plate support when the weighing pan is removed!

Observe the regulations of your company and industry with regard to cleaning intervals and permitted cleaning agents.

6 Technical data, interfaces, and accessories

In this chapter you will find technical specifications for your scale, information about standards and directives, and a list of currently available accessories.

6.1 General data and delivered items

Applications	Weighing Piece counting Piece counting with second scale Dynamic weighing
Settings	Selectable resolution Selectable weighing unit Automatic taring function Automatic zeroing (at switchon and during operation) Filter for adaptation to environmental conditions (vibration adapter) Filter for adaptation to weighing mode, e.g. dispensing (weighing process adapter) Adding mode for reference determination (piece counting) Variable reference piece count (piece counting) Automatic reference optimization (piece counting) Switchoff function, standby and energy-saving modes Display backlighting Graphical weighing range display
Display	Liquid crystal display (LCD), 37 mm high, backlit, with linear weighing range display
Interface	1 RS232C interface built in (for data s. Chapter 6.4), optional interfaces available
Environmental conditions	Accuracy is guaranteed in the following ranges: Temperature range: –10 ... +40 °C / 14 ... 104 °F Relative air humidity: 15 ... 85% rh (noncondensing) Overvoltage category: II Pollution degree: 2
Power supply	Direct connection to power supply (cable with country-specific plug): Scale without OptionPac: Scale with OptionPac: 120V, 60 Hz, 90 mA 100 – 250V / 47 – 63 Hz / 300 mA 100V, 50/60 Hz, 90 mA 230V, 50 Hz, 70 mA 240V, 50 Hz, 70 mA
Weight and dimensions	See Chapter 6.3
Standard delivery package	Complete scale (terminal and weighing platform assembled) Operating instructions Open-end wrench (for leveling)

6.2 Type codes and model-specific data

6.2.1 Type codes

Spider BC XY

Example: Spider BC CC60 = Spider BC 60 kg with weighing platform 600 x 800 mm

Weighing platforms

Designation	A	BB	B	BC	CC	DS	D	E	ES	F
Depth [mm]	240	300	400	500	600	1000	1250	1500	1500	Free size 1000 - 1500
Length [mm]	300	400	500	650	800	1000	1000	1250	1500	Free size 1000 - 1500

6.2.2 Model-specific data

Scale capacity	Max. capacity		Readability	
	Weighing range		Weighing range	
	1	2	1	2
6 kg	3 kg	6 kg	1 g	2 g
15 kg	6 kg	15 kg	2 g	5 g
35 kg	15 kg	35 kg	5 g	10 g
60 kg	30 kg	60 kg	10 g	20 g
150 kg	60 kg	150 kg	20 g	50 g
300 kg	150 kg	300 kg	50 g	100 g
600 kg	300 kg	600 kg	100 g	200 g
600 kg	600 kg	*	200 g	*
1500 kg	1500 kg	*	500 g	*
3000 kg	3000 kg	*	1000 g	*

* Single-range scale

6.3 Dimensions and weights

6.3.1 Terminal

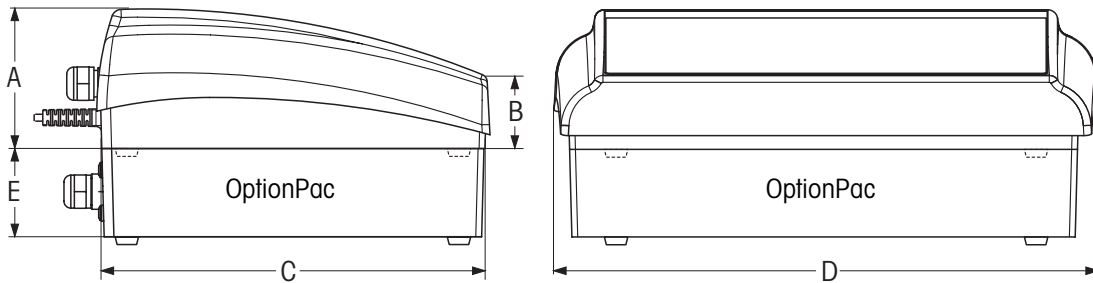

	A ¹⁾	B	C	D	E (OptionPac) ¹⁾
Dimensions	71 mm	36 mm	200 mm	277 mm	49 mm
Net weight	3.5 kg				

¹⁾ Without fixed feet (with fixed feet: +4.5 mm)

6.3.2 Weighing platforms

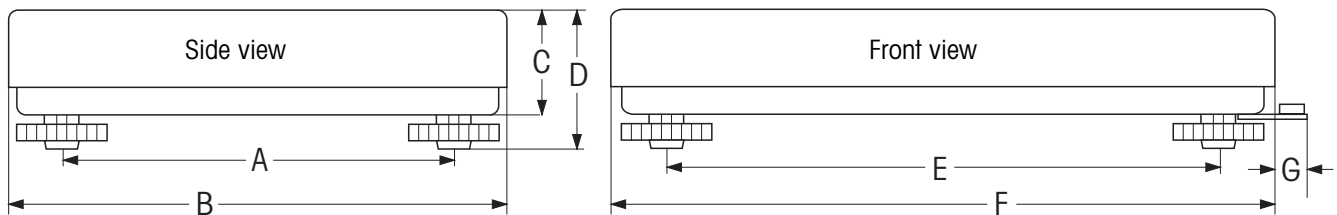

Type	A [mm]	B [mm]	C [mm]	D ¹⁾ [mm]	E [mm]	F [mm]	G [mm]	Net weight [kg] ²⁾	Material
A	175	240	62	80	235	300	22	5.6	Chrome-nickel steel
BB	235	300	66	86	335	400	22	9.7	Chrome-nickel steel
B	335	400	66	86	435	500	22	20.2	Chrome-nickel steel
BC	435	500	85	100	587	650	22	24.8	Painted metal ³⁾
CC	503	600	97	115	724	800	21	29.0	Painted metal ³⁾
DS	–	1000	–	78	–	1000	–	116	Painted metal
D	–	1000	–	78	–	1250	–	140	Painted metal
E	–	1250	–	78	–	1500	–	185	Painted metal
ES	–	1500	–	78	–	1500	–	259	Painted metal
F	–	⁴⁾	–	⁴⁾	–	⁴⁾	–	⁴⁾	Painted metal

¹⁾ With leveling feet fully screwed in

²⁾ Upper and lower parts of the weighing platform incl. weighing cell and weighing pan

³⁾ Also optionally available in chrome-nickel steel

⁴⁾ Free size of platform (1000 x 1000 mm to 1500 x 1500 mm)

6.4 RS232C and RS422/485 interfaces

Spider BC scales can be fitted with various different interfaces at the factory.

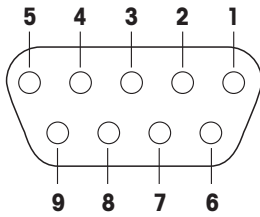

Standard Spider BC scales are fitted with one voltage interface according to EIA RS-232C/DIN 66020 (CCITT V24/V.28, maximum cable length 50 ft/15 m). As an option, the terminal is also available with 2 interfaces. The corresponding interface boards replace the standard interface. All interfaces have a 9-pin sub-D socket (female).

The illustration at left shows the numbering of the individual pins (looking onto the socket). The pin designations for the different interfaces are shown in the following tables.

Standard interface

Interface type:	RS232C
Pin 1	VCC
Pin 2	TxD 1
Pin 3	RxD 1
Pin 4	Not available for connection
Pin 5	GND
Pin 6	Not available for connection
Pin 7	Not available for connection
Pin 8	Not available for connection
Pin 9	VCC

TxD: transmit data RxD: receive data GND: signal ground VCC: supply voltage +5V

Optional: 2 RS232C interfaces

Interface no./type:	Interface 1/RS232C	Interface 2/RS232C
Pin 1	Not used	Not used
Pin 2	TxD 1	TxD 2
Pin 3	RxD 1	RxD 2
Pin 4	Not used	Not used
Pin 5	GND	GND
Pin 6	Not used	Not used
Pin 7	Not used	Not used
Pin 8	Not used	Not used
Pin 9	VCC	VCC

TxD: transmit data RxD: receive data GND: signal ground VCC: supply voltage +5V

Optional: 1 RS422/485 and 1 RS232C interface

Interface no./type:	Interface 1		Interface 2
	RS422 (4-wire)	RS485 (2-wire)	RS232C
Pin 1	Not used	Not used	Not used
Pin 2	TxD 1-	TxD 1-/RxD 1-	TxD 2
Pin 3	RxD 1-	—————	RxD 2
Pin 4	Not used	Not used	Not used
Pin 5	GND	GND	GND
Pin 6	Not used	Not used	Not used
Pin 7	TxD 1+	TxD 1+/RxD 1+	Not used
Pin 8	RxD 1+	—————	Not used
Pin 9	VCC	VCC	VCC

TxD: transmit data RxD: receive data GND: signal ground VCC: supply voltage +5V

There is important information concerning networking via the RS422/485 interface in Chapter 5.1.4.

6.5 Analog option

The Spider BC can be fitted at the factory with an additional analog option which is built into the OptionPac. The analog option permits connection of a second weighing platform which delivers analog signals. This makes it possible to configure compact two-scale systems using only one terminal. After an analog weighing platform has been connected, its parameters must be entered in the menu. These are stored on the board of the analog option. This preparatory work is carried out by the service technician and is not described in these instructions. When the parameters have been input, the same settings are available in the "SCALE" menu block for the second scale as for the Spider scale itself (settings for resolution, taring, zeroing, filter). **Note:** In the "COMMUNICATION -> Option" menu the second weighing platform can be defined as the reference or bulk scale for piece counting, or it can be deactivated.

To connect a weighing platform to the analog option, the bottom plate of the OptionPac must be removed (8 screws Torx T20). The connecting cable of the weighing platform must be led through the bushing of the OptionPac and connected to the terminal strip on the board of the analog option as follows:

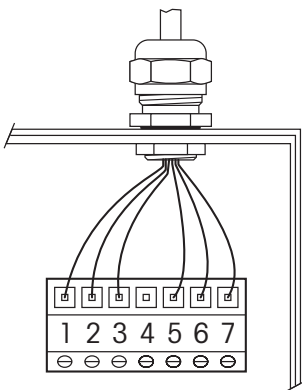

Terminal	Function
1	- Excitation (GND)
2	- Sense
3	- Signal
4	Shield
5	+ Signal
6	+ Sense
7	+ Excitation (+8.2 V)

6.6 Accessories

You can order the following accessories from your authorized METTLER TOLEDO representative:

Accessory	Art. no.
Protective cover for terminal	21255045
Wall mount for terminal	21255258
Mounting plate for fastening terminal to weighing platform	21255259
Second display	21250064
Sprinter 1 printer (Euro version)	21253399
Sprinter 1 printer (UK version)	21253745
Interface cable for Sprinter 1 printer	21253677
Interface cable for Spider-PC connection	00410024
Interface cable for Spider-Spider connection	21252588
Anti theft device	00229175
Stand 300 mm	21255254
Stand 400 mm	21255255
Stand 500 mm	21255256
Stand 650 mm	21255257
Floor stand	00506721
Stand base (for floor stand)	00503700
Roller track 300 x 400 mm	21253930
Roller track 400 x 500 mm	21253931
Roller track 500 x 650 mm	21253932
Roller track 600 x 800 mm	00504852
Roller top 300 x 400 mm	21254155
Roller top 400 x 500 mm	21254156
Roller top 500 x 650 mm	21254157
Roller top 600 x 800 mm	21254844
Approach ramp 1000 mm	00506548
Approach ramp 1250 mm	00506549
Approach ramp 1500 mm	00506550
Pit frame 1000 x 1000 mm	00506481
Pit frame 1000 x 1250 mm	00505315
Pit frame 1250 x 1500 mm	00505316
Pit frame 1500 x 1500 mm	00505379

6.7 Declaration of conformity

We, **Mettler-Toledo (Albstadt) GmbH, Unter dem Malesfelsen 34, D-72458 Albstadt** declare under our sole responsibility that the product

Spider BC from serial no. 2494000, to which this declaration relates is in conformity with the following directives and standards.

Directive	Applicable standard
relating to electrical equipment designed for use within certain voltage limits (73/23/EEC; amended by directive 93/68/EEC)	EN61010-1 (Safety Regulations) EN60529 IP65 (IP degree of protection)
relating to electromagnetic compatibility (89/336/EEC; amended by directive 93/68/EEC; 92/31/EEC)	EN61326-1 Class B (Emission) EN61326-1 (Immunity) EN61000-3-2 (Harmonic Oscillations) EN61000-3-3 (Voltage Fluctuations)
relating to non-automatic weighing instruments (90/384/EEC; amended by directive 93/68/EEC) ¹⁾	EN45501 ¹⁾ (Metrological Aspects) 

¹⁾ applies only to certified scales (approval/test certificate no. TC5818 for terminals (without weighing platform) and T5819 for complete scales (terminal and weighing platform)).

Albstadt, January 2002

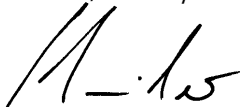

Roland Schmider, General Manager

Mettler-Toledo (Albstadt) GmbH

Heiko Carls, Quality Manager

Important notice for verified weighing instruments in EC countries

 Weighing instruments verified at the place of manufacture bear the preceding mark on the packing label and a green "M" sticker on the descriptive plate. They may be set to work immediately.

 Weighing instruments which are verified in two steps have no green "M" on the descriptive plate and bear the preceding identification mark on the packing label. The second step of the verification must be carried out by the approved Mettler-Toledo service or by the W & M authorities. Please contact your Mettler-Toledo organization.

The first step of the verification has been carried out at the manufacturing plant. It comprises all tests according to EN45501-8.2.2. Scales with analog connection to the weighing platform require an additional test according to EN45501-3.5.3.3. However, this test is not mandatory if the terminal bears the same serial number as the weighing platform.

If national regulations in individual countries limit the period of validity of the certification, the operator of such a scale is himself responsible for its timely re-certification.

USA

This equipment has been tested and found to comply with the limits for a Class A digital device, pursuant to both Part 15 of the FCC Rules and the radio interference regulations of the Canadian Department of Communications. These limits are designed to provide reasonable protection against harmful interference when the equipment is operated in a commercial environment. This equipment generates, uses and can radiate radio frequency energy and, if not installed and used in accordance with the instruction manual, may cause harmful interference to radio communications. Operation of this equipment in a residential area is likely to cause harmful interference, in which case the user will be required to correct the interference at his own expense.



Canada

ICES-001 Notice for Industrial, Scientific and Medical Radio Frequency Generators: This ISM apparatus meets all requirements of the Canadian Interference-Causing Equipment Regulations. Please note that this requirement is only for generators which operate at over 10 kHz.

Avis de l'ICES-001, générateurs de radiofréquences dans le domaine industriel, scientifique et médical: Cet appareil ISM (industriel, scientifique et médical) satisfait à toutes les exigences définies par la réglementation canadienne en matière d'équipements générant des perturbations radioélectriques. Veuillez noter qu'il s'agit d'une exigence concernant uniquement les générateurs fonctionnant au-delà de 10 kHz.

6.8 Safety tests

The terminals and scales of the Spider SW, BC, and FC series have been inspected by accredited testing laboratories. They have passed the **safety tests** stated below and bear the corresponding test marks. Their production takes place under the control of the testing authorities.

Country	Test Mark	Standard
Canada USA		CAN/CSA.C22.2 No. 1010.1-92 UL Std. No. 3101-1
Europe		EN61010-1:93 + A2:95 EN61326-1:97 + A1:98 Class B EN61326-1:97 + A1:98 Industry
Switzerland		EN61010-1:93 + A2:95 EN61326-1:97 + A1:98 Class B EN61326-1:97 + A1:98 Industry
Other countries	CB Scheme (no marking)	EN61010-1:93 + A2:95 EN61326-1:97 + A1:98 Class B EN61326-1:97 + A1:98 Industry

Emergency password for supervisor access to menu

Please cut out and keep in a safe place!

Use this emergency password if you have defined a supervisor password and then forgotten it.

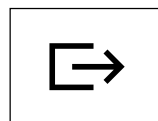
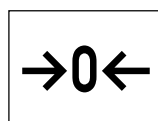
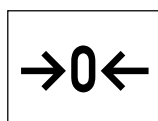
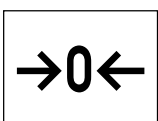

Press the «→0←» key 3 times,
followed by «☐→».



To preserve the value of your METTLER TOLEDO scale and protect its future: METTLER TOLEDO servicing assures the quality and measuring accuracy of your METTLER TOLEDO instrument for years to come. Please ask for full details of our attractive terms of service. Thank you.



P21255138

Subject to technical changes and availability of the accessories supplied with the instruments.

Printed on 100% chlorine-free paper.
Because we care.

© Mettler-Toledo (Albstadt) GmbH 2002 21255138A Printed in Germany 0202/2.12

Mettler-Toledo (Albstadt) GmbH, D-72423 Albstadt, Tel. +49-7431 14-0, Fax +49-7431 14-371, Internet: <http://www.mt.com>

AT Mettler-Toledo Ges.m.b.H., A-1100 Wien, Tel. (01) 604 19 80, Fax (01) 604 28 80
AU Mettler-Toledo Ltd., Port Melbourne, Victoria 3207, Tel. (03) 9644 5700, Fax (03) 9645 3935
BE n.v. Mettler-Toledo s.a., B-1932 Zaventem, Tel. (02) 334 02 11, Fax (02) 378 16 65
BR Mettler-Toledo Indústria e Comércio Ltda., São Paulo, CEP 06465-130, Tel. (11) 421 5737, Fax (11) 725 1962
CH Mettler-Toledo (Schweiz) AG, CH-8606 Greifensee, Tel. (01) 944 45 45, Fax (01) 944 45 10
CN Mettler-Toledo Changzhou Scale Ltd., Changzhou City, Jiangsu 213001, Tel. (519) 664 20 40, Fax (519) 664 19 91
CZ Mettler-Toledo, s.r.o., CZ-100 00 Praha 10, Tel. (2) 72 123 150, Fax (2) 72 123 170
DE Mettler-Toledo GmbH, D-35353 Giessen, Tel. (0641) 50 70, Fax (0641) 52 951
DK Mettler-Toledo A/S, DK-2600 Glostrup, Tel. (43) 27 08 00, Fax (43) 27 08 28
ES Mettler-Toledo S.A.E., E-08038 Barcelona, Tel. (93) 223 76 00, Fax (93) 223 02 71
FR Mettler-Toledo s.a., F-78222 Viroflay, Tél. (01) 309 717 17, Fax (01) 309 716 16
HK Mettler-Toledo (HK) Ltd., Kowloon HK, Tel. (852) 2744 1221, Fax (852) 2744 6878
HR Mettler-Toledo, d.o.o., CR-10000 Zagreb, Tel. (1) 29 20 633, Fax (1) 29 58 140
HU Mettler-Toledo Kft, H-1173 Budapest, Tel. (1) 257 9889, Fax (1) 257 7030
IN Mettler-Toledo India Pvt Ltd, Mumbai 400 072, Tel. (22) 857 08 08, Fax (22) 857 50 71
IT Mettler-Toledo S.p.A., I-20026 Novate Milanese, Tel. (02) 333 321, Fax (02) 356 29 73
JP Mettler-Toledo K.K., Shiromi, J-Osaka 540, Tel. (6) 949 5901, Fax (6) 949 5945
KR Mettler-Toledo (Korea) Ltd., Seoul (135-090), Tel. (82) 2 518 20 04, Fax (82) 2 518 08 13
MY Mettler-Toledo (M) Sdn.Bhd., 40100 Shah Alam, Tel. (603) 7845 5773, Fax (603) 7845 8773
MX Mettler-Toledo S.A. de C.V., Mexico CP 06430, Tel. (5) 547 5700, Fax (5) 541 2228
NL Mettler-Toledo B.V., NL-4000 HA Tiel, Tel. (0344) 638 363, Fax (0344) 638 390
NO Mettler-Toledo A/S, N-1008 Oslo, Tel. (22) 30 44 90, Fax (22) 32 70 02
PL Mettler-Toledo, Sp. z o.o., PL-02-929 Warszawa, Tel. (22) 651 92 32, Fax (22) 651 71 72
RU Mettler-Toledo AG, 10 1000 Moskau, Tel. (095) 921 68 12, Fax (095) 921 63 53
SE Mettler-Toledo AB, S-12008 Stockholm, Tel. (08) 702 50 00, Fax (08) 642 45 62
SEA Mettler-Toledo (SEA), 40100 Shah Alam, Tel. (603) 7845 5373, Fax (603) 7845 3478
SG Mettler-Toledo (S) Pte. Ltd., Singapore 139959, Tel. (65) 890 0011, Fax (65) 890 0012
SK Mettler-Toledo, service s.r.o., SK-83103 Bratislava, Tel. (7) 525 2170, Fax (7) 525 2173
SI Mettler-Toledo, d.o.o., SI-1236 Trzin, Tel. (016) 162 18 01, Fax (061) 162 17 89
TH Mettler-Toledo (Thailand), Bangkok 10310, Tel. (662) 723 0300, Fax (662) 719 6479
TW Mettler-Toledo Pac Rim AG, Taipei, Tel. (886) 2 2579 5955, Fax (886) 2 2579 5977
UK Mettler-Toledo Ltd., Leicester, LE4 1AW, Tel. (0116) 235 0888, Fax (0116) 236 5500
US Mettler-Toledo, Inc., Columbus, Ohio 43240, Tel. (614) 438 4511, Fax (614) 438 4900

For all other countries: Mettler-Toledo GmbH, PO Box VI-400, CH-8606 Greifensee, Tel. (01) 944 22 11, Fax (01) 944 31 70