

MODULE COMBINATIONS					DIMENSIONAL CHART						
SCALE SIZE	FIRST REF "D" DIM	MIDDLE REF "E" DIM	MIDDLE REF "F" DIM	TERMINAL REF "G" DIM	"A" FDN LENGTH	"B" OVERALL LENGTH	"C"	"D"	"E"	"F"	"G"
65"	17.5'	15'	15'	17.5'	65'-2"	65'-1 1/4"	64'-6"	17'-4 1/2"	14'-10 1/2"	14'-10 1/2"	17'-4 1/2"
70"	17.5'	17.5'	17.5'	17.5'	70'-2"	70'-1 1/4"	69'-6"	17'-4 1/2"	17'-4 1/2"	17'-4 1/2"	17'-4 1/2"
75"	17.5'	20'	20'	17.5'	75'-2"	75'-1 1/4"	74'-6"	17'-4 1/2"	19'-10 1/2"	19'-10 1/2"	17'-4 1/2"
80"	20'	20'	20'	20'	80'-2"	80'-1 1/4"	79'-6"	19'-10 1/2"	19'-10 1/2"	19'-10 1/2"	19'-10 1/2"

**NOTES:**

1. FOUNDATION LENGTH DIMENSION SHOWN IS NOMINAL. ACTUAL TOLERANCE IS  $-0 +1"$
2. THE COOL MODULE SUFFIX IS USED TO DESIGNATE MODULE ASSEMBLY.
3. APPLY LOCTITE #242 TO ALL GAP COVER BOLTS
4. APPLY A 1/4" BEAD OF DIELECTRIC COMPOUND IN THE MALE CONNECTOR OF LOAD CELL BEFORE FINAL CONNECTION.
5. IF DIELECTRIC COMPOUND BECOMES CONTAMINATED, CLEAN CONNECTOR WITH TB202627 CONNECTOR CLEANER. REAPPLY NEW COMPOUND TO THE CONNECTOR.

**WIRING NOTES:**

1. THE HAZARDOUS AREA WIRING AND LIGHTNING PROTECTION KIT IS SPECIFIC FOR THE SUPPLY VOLTAGE AND THE INDICATOR USED. IT MUST BE INCLUDED FOR INTRINSICALLY SAFE COMPLIANCE IN HAZARDOUS LOCATIONS.

**IMPORTANT:**  
THE INTERIOR SURFACE OF ALL LOAD CELL RECEIVERS (BOTH TOP AND BOTTOM) MUST BE GREASED WITH TN203217 DURING CELL INSTALLATION.

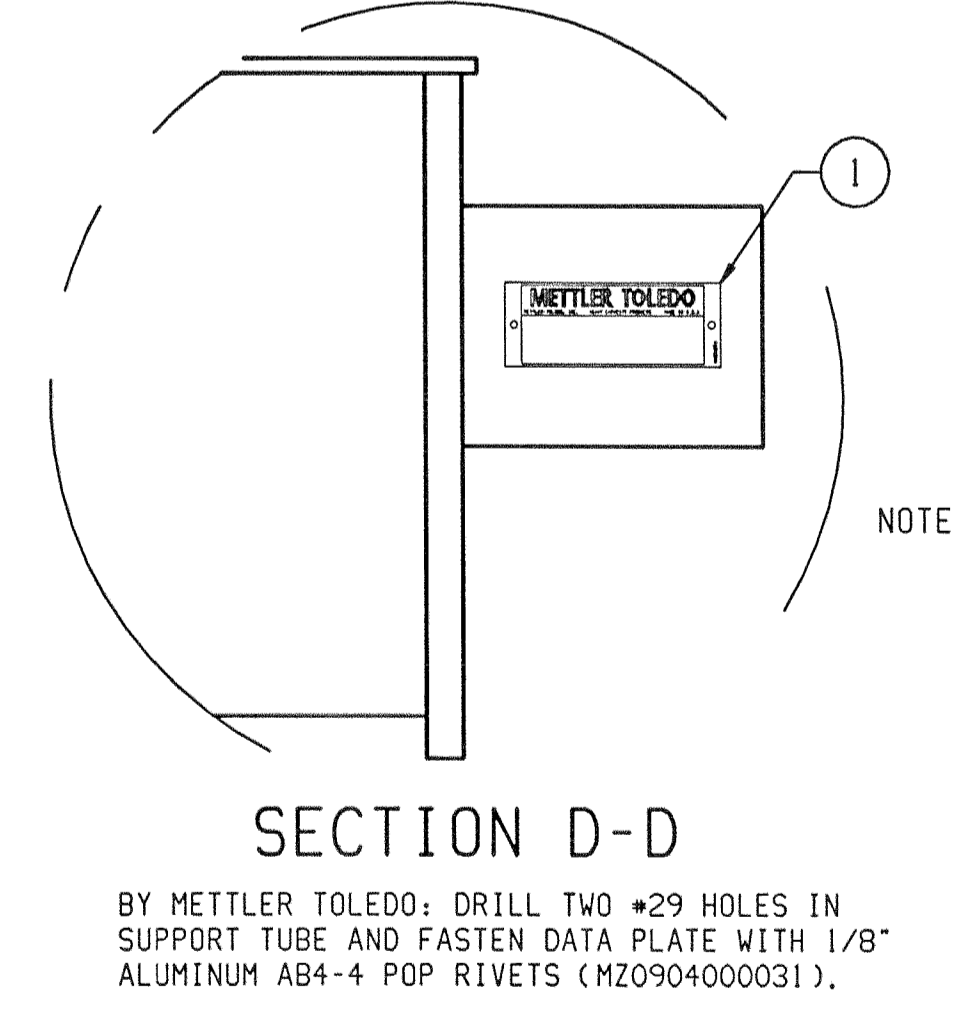
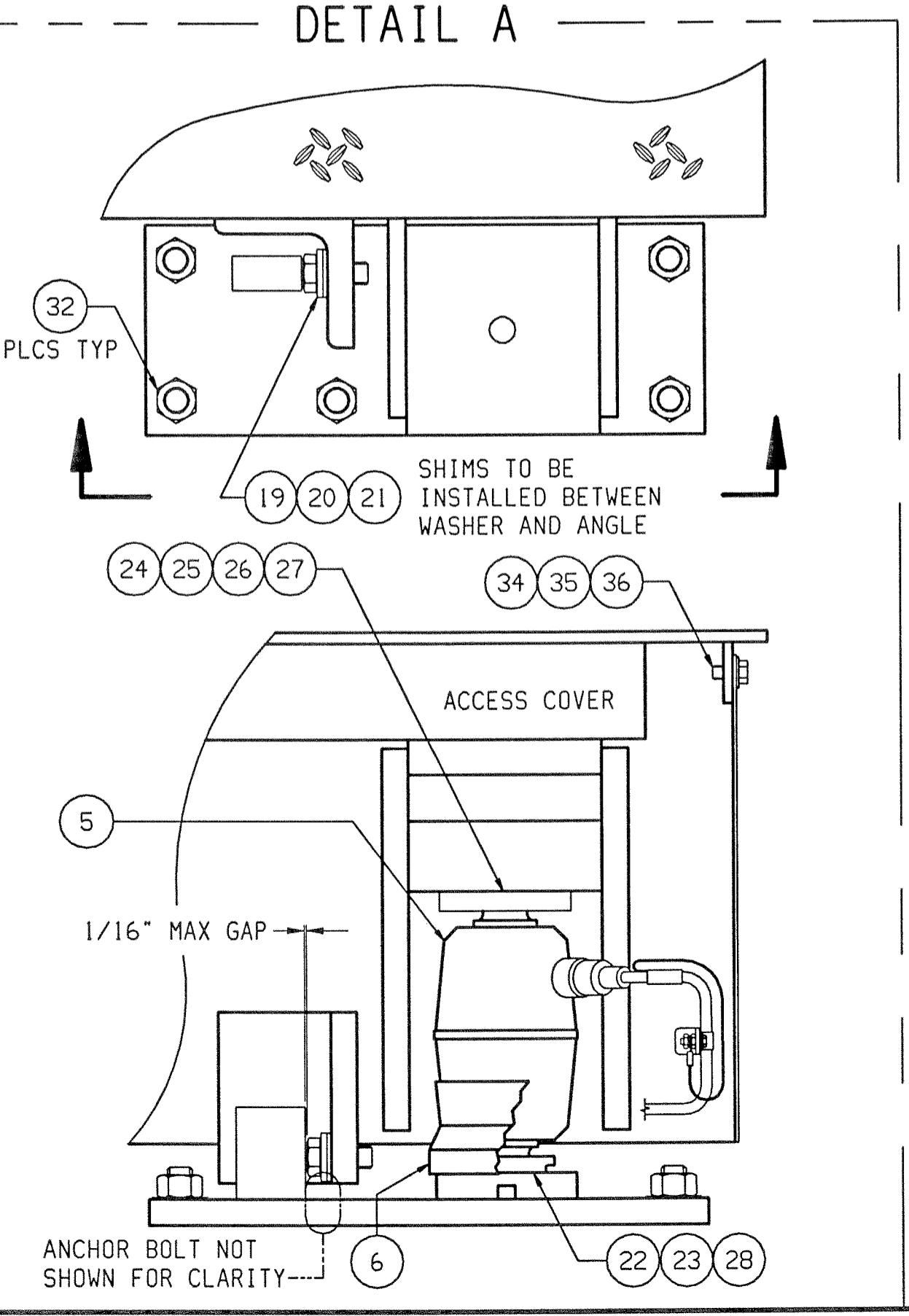
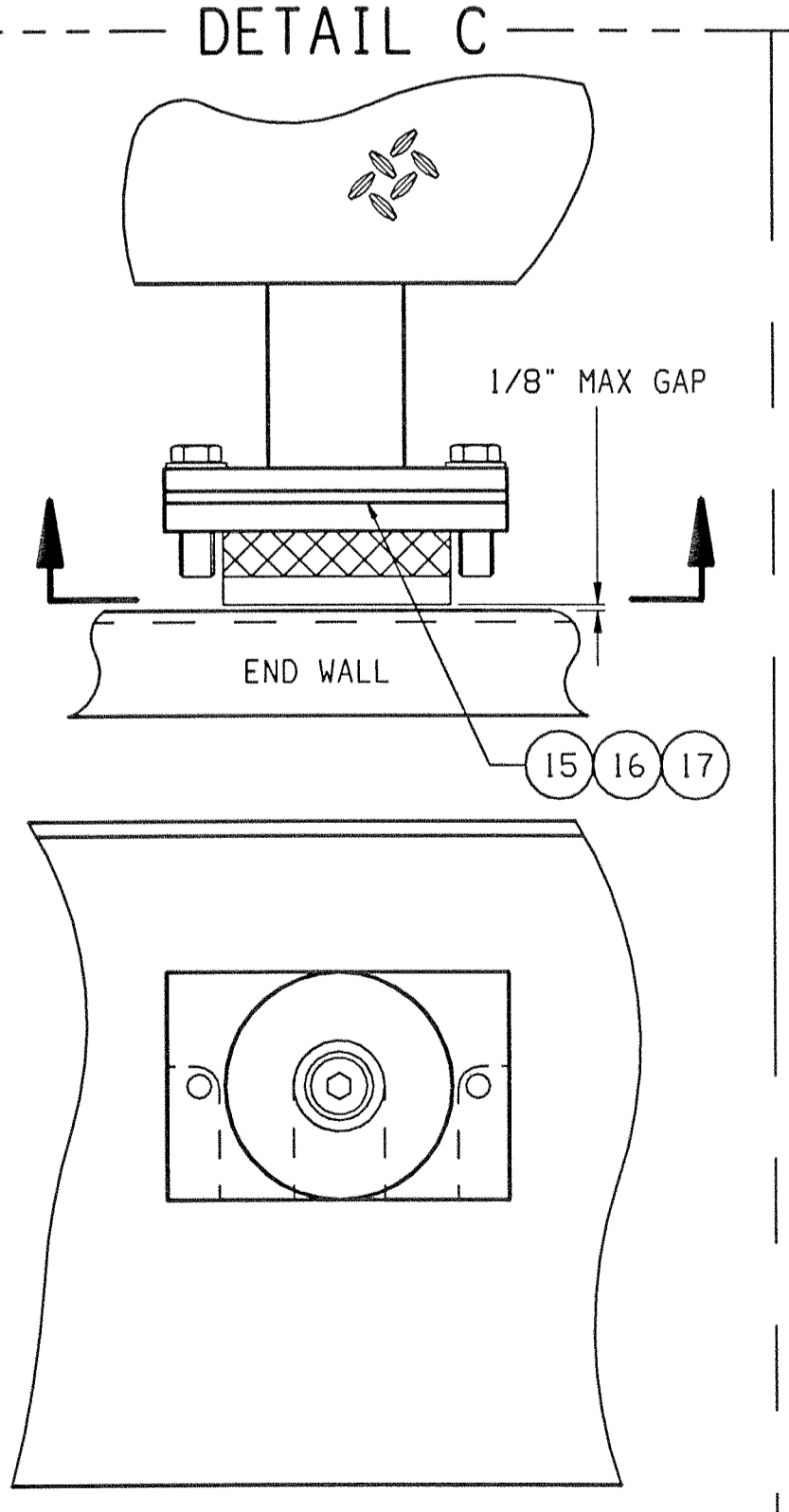
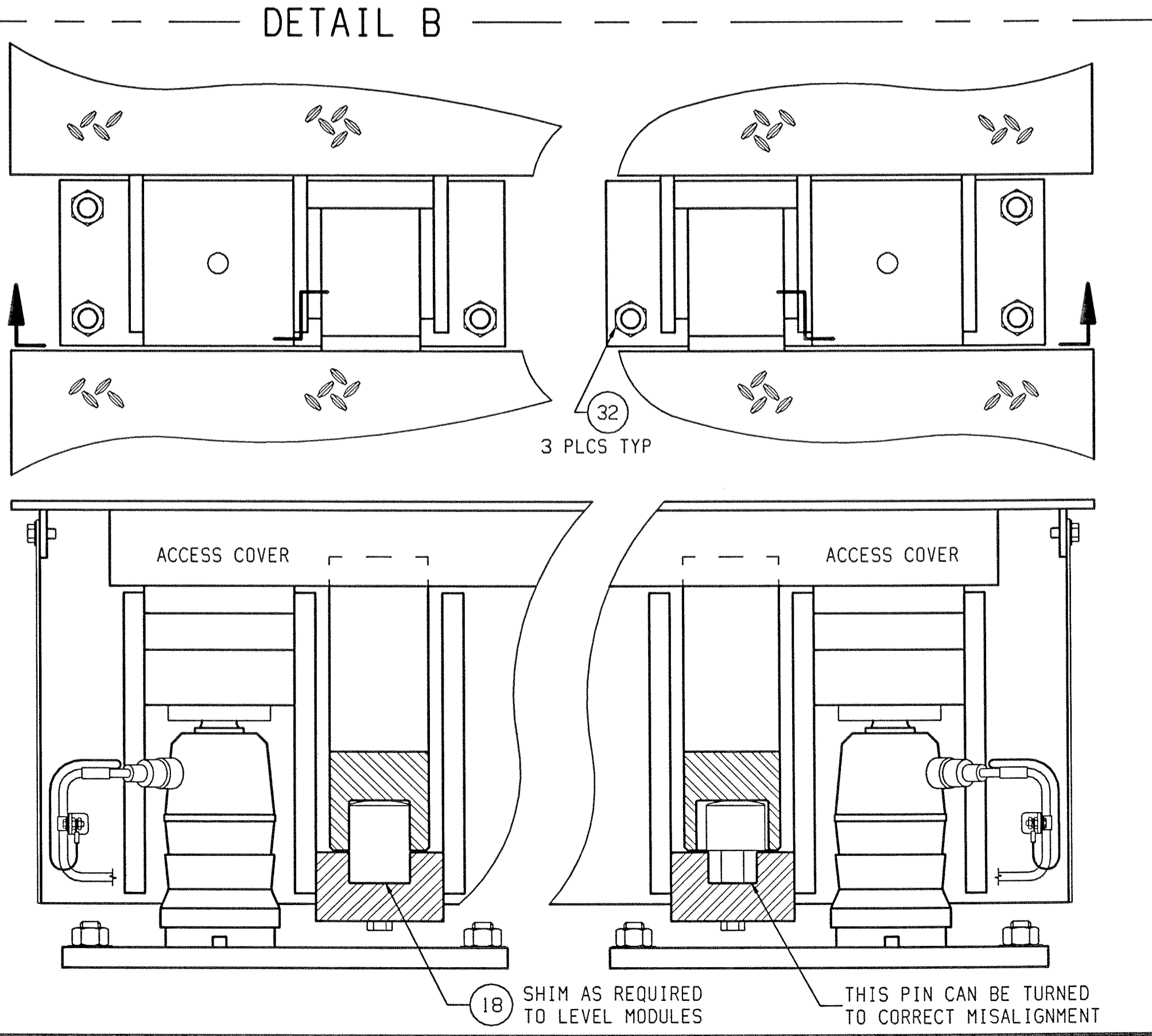

ITEM	QTY	PART NUMBER	DESCRIPTION
36	20	MZ0901030019	WASHER, 3/8" SS
35	20	MZ0901010030	HHCS, 3/8-16x3/4" 18-8 SS
34	10	TA202688	SIDE COVER
33	2	TN203217	LUBRICANT, LOADCELL-RECEIVER
32	38	TN203216	ANCHOR BOLT
31	1	TN203056	CONNECTOR DIELECTRIC COMPOUND
30	1	TB202627	CONNECTOR CLEANER
29	1	MZ0602000117	LOCTITE #242 THREADLOCKER
28	10	TA202695	BOTTOM HEX RECEIVER
27	10	TA205945	TOP RECEIVER WITH O-RING
26	10	TA200833-3	TOP RECEIVER SHIM 7 GA
25	10	TA200833-2	TOP RECEIVER SHIM 16 GA
24	10	TA200833-1	TOP RECEIVER SHIM 11 GA
23	5	TN202993-2	BOTTOM RECEIVER SHIM 11 GA
22	5	TN202993-3	BOTTOM RECEIVER SHIM 16 GA
21	4	TA200357-3	SLOTTED SHIM 22 GA (.031)
20	4	TA200357-2	SLOTTED SHIM 16 GA (.062)
19	4	TA200357-1	SLOTTED SHIM 11 GA (.125)
18	3	TA202990-2	COUPLER SHIM 16 GA (.062)
17	2	TA200856-3	END BUMPER SHIM 16 GA (.062)
16	2	TA200856-2	END BUMPER SHIM 11 GA (.125)
15	3	TA200856-1	END BUMPER SHIM 1/4"

**HARDWARE KIT OF PARTS: TC204124-1**  
KOP TC204124-2 DOES NOT INCLUDE ITEMS 34,35 AND 36

ITEM	QTY	PART NUMBER	DESCRIPTION
--	1	TC204124-1	HARDWARE KIT OF PARTS
--	1	TN204138	STANDARD TOUCH-UP PAINT
--	1	TN204213	PREMIUM TOUCH-UP PAINT
10	1	REF COOD SUFFIX	TERMINAL MODULE, STD WIRING
		REF COOD SUFFIX	TERMINAL MODULE, HAZ WIRING
9	1	REF COOC SUFFIX	MIDDLE MODULE, STD WIRING
		REF COOG SUFFIX	MIDDLE MODULE, HAZ WIRING
8	1	REF COOB SUFFIX	MIDDLE MODULE, STD WIRING
		REF COOH SUFFIX	MIDDLE MODULE, HAZ WIRING
7	1	REF COOA SUFFIX	FIRST MODULE, STD WIRING
		REF COOF SUFFIX	FIRST MODULE, HAZ WIRING
6	10	TN203173	GASKET (USED WITH 760 POWERCELL)
		TN203705	BOOT (USED WITH MTX LOAD CELL)
5	10	*14002900A	LOAD CELL, MODEL 760 POWERCELL, 45m+
		*15475900A	LOAD CELL, MTX, 45m+ CAPACITY
4	2	TB203076-4	BUMPER BASEPLATE RIGHT
3	2	TB203076-3	BUMPER BASEPLATE LEFT
2	6	TB203076-2	BASEPLATE
1	1	MN31004	DATA PLATE

**MAJOR BILL OF MATERIAL**  
\* LETTER PREFIX SUBJECT TO CHANGE

REV	CHANGE	BY	DATE	SCALE	DATE	APPD.	REV
A	ADDED 20" MODULE AND 11" WIDE	HBW	07/20/99	.25	06/28/99		
B	REVISED TO STANDARD FORM	HBW	02/07/01				
C	ITEM 27 WAS TA200835	PAW	07/28/03				

UNLESS OTHERWISE SPECIFIED, ALL DIMENSIONS ARE IN INCHES, AND DIMENSIONAL TOLERANCES ARE:  
FRACTIONAL .XX ±.02 ANGULAR ±.5°  
DECIMAL .XXX ±.005

**METTLER TOLEDO**  
TITLE 7563A GENERAL LAYOUT, FOUR MODULE SCALE  
TC204124