

METTLER TOLEDO

Operation Manual Transmitter pH M300



Transmitter pH M300
52 121 304

Operation Manual Transmitter pH M300

Index

1	Introduction	7
2	Safety instructions	7
2.1	Definition of equipment and documentation symbols and designations	7
2.2	Correct disposal of the unit	8
3	Unit overview	9
3.1	Overview 1/4DIN	9
3.2	Overview 1/2DIN	10
3.3	Control/navigation keys	11
3.3.1	Menu structure	11
3.3.2	Navigation keys	11
3.3.2.1	Navigating the menu tree	11
3.3.2.2	Escape	12
3.3.2.3	Enter	12
3.3.2.4	Menu	12
3.3.2.5	Calibration mode	12
3.3.2.6	Info mode	12
3.3.3	Navigation of data entry fields	12
3.3.4	Entry of data values, selection of data entry options	12
3.3.5	Navigation with ↑ in Display	13
3.3.6	"Save changes" dialog	13
3.4	Display	13
4	Installation instruction	14
4.1	Unpacking and inspection of equipment	14
4.1.1	Panel cutout dimensional information - 1/4DIN models	14
4.1.2	Installation procedure - 1/4DIN models	15
4.1.3	Panel cutout dimensional information - 1/2DIN models	16
4.1.4	Installation procedure - 1/2DIN models	17
4.2	Connection of power supply	18
4.2.1	1/4DIN housing (panel mount)	18
4.2.2	1/2DIN housing (wall mount)	19
4.3	Connector PIN definition	20
4.3.1	TB1 and TB2 for 1/2DIN and 1/4DIN versions	20
4.3.2	TB3 for 1/2DIN and 1/4DIN versions	20
4.4	Connection of sensor	21
4.4.1	Connecting the sensor to the VP cable	21
4.4.2	VP cable assignment	22
4.5	Wiring examples (using TB3)	23
4.5.1	Example 1 (using TB3)	23
4.5.2	Example 2 (using TB3)	24
4.5.3	Example 3 (using TB3)	25
4.5.4	Example 4 (using TB3)	26
5	Placing transmitter in, or out, of service	27
5.1	Placing transmitter in service	27
5.2	Placing transmitter out of service	27
6	Quick setup	28
6.1	Channel selection for the display	28
6.2	Analog outputs	28
6.3	Set points	28
7	Calibration	30
7.1	Exit calibration mode	30
7.2	Enter calibration mode	30
7.3	pH calibration	30
7.3.1	One point calibration	30
7.3.2	Two point calibration	31
7.3.3	Process calibration	32
7.4	mV calibration	32
7.5	Temperature calibration	33

	7.5.1	One-point temperature calibration	33
	7.5.2	Two-point temperature calibration	33
7.6		Edit pH	34
7.7		Edit mV	34
7.8		Verify	35
8	Configure		36
8.1		Exit configuration mode	36
8.2		Enter configuration mode	36
8.3		Measurement	36
	8.3.1	Channel setup	37
	8.3.2	Temperature source	37
	8.3.3	pH	37
	8.3.4	Set averaging	38
8.4		Analog outputs	39
8.5		Set points	40
8.6		Alarm/Clean	41
	8.6.1	Alarm	41
	8.6.2	Clean	42
8.7		Display	42
	8.7.1	Measurement	42
	8.7.2	Resolution	43
	8.7.3	Backlight	43
	8.7.4	Name	44
8.8		Hold outputs	44
9	System		45
9.1		Set language	45
9.2		USB	45
9.3		Passwords	46
	9.3.1	Changing passwords	46
	9.3.2	Configuring menu access for operator	46
9.4		Set/clear lockout	46
9.5		Reset	47
	9.5.1	Reset system	47
	9.5.2	Reset meter calibration	47
	9.5.3	Reset analog calibration	48
10	PID setup		49
10.1		Enter PID setup	50
10.2		PID A/M	50
10.3		Mode	51
10.4		Tune parameters	52
	10.4.1	PID assignment & tuning	52
	10.4.2	Setpoint & deadband	52
	10.4.3	Proportional limits	52
	10.4.4	Corner points	52
10.5		PID display setup	53
11	Service		54
11.1		Diagnostics	54
	11.1.1	Model/software revision	54
	11.1.2	Digital input	55
	11.1.3	Display	55
	11.1.4	Keypad	55
	11.1.5	Memory	55
	11.1.6	Set relay	56
	11.1.7	Read relays	56
	11.1.8	Set analog outputs	56
	11.1.9	Read analog outputs	57
11.2		Calibrate	57
	11.2.1	Calibrate meter	57
		11.2.1.1 Voltage	58
		11.2.1.2 Temperature	58
		11.2.1.3 Rg diagnostic	59
		11.2.1.4 Rr diagnostic	59

	11.2.2 Calibrate analog	59
	11.2.3 Calibrate unlock	60
11.3	Tech Service	60
12	Info	61
12.1	Messages	61
12.2	Calibration data	61
12.3	Model/software revision	62
13	Maintenance	63
13.1	For technical support	63
13.2	Front panel cleaning	63
14	Trouble shooting	64
14.1	Warning- and alarmlist	65
14.2	Changing the fuse	65
15	Accessories and spare parts	66
16	Specifications	66
16.1	General specifications	66
16.2	Electrical specifications for 1/2DIN and 1/4DIN versions	66
16.3	Mechanical specifications for 1/4DIN version	67
16.4	Mechanical specifications for 1/2DIN version	67
16.5	Environmental specifications for 1/2DIN and 1/4DIN versions	67
17	Default tables	68
18	Warranty	69
19	UL Statement (pending)	69
20	Buffer tables	70
20.1	Mettler-9	70
20.2	Mettler-10	71
20.3	NIST Technical Buffers	71
20.4	NIST standard buffers (DIN 19266: 2000-01)	72
20.5	Hach buffers	73
20.6	Ciba (94) buffers	73
20.7	Merck Titrisols, Reidel Fixanals	74
20.8	WTW buffers	74

1 Introduction

Statement of Intended Use - The M300 pH transmitter is a single channel online process instrument for measuring pH of fluids. It will interface with a variety of different Mettler-Toledo sensors, which connect to the transmitter using cables of varied lengths.

A large four line backlit Liquid Crystal Display conveys measuring data and setup information. The menu structure allows the operator to modify all operational parameters by using keys on the front panel. A menu-lockout feature, with password protection, is available to prevent the unauthorized use of the meter. The M300 transmitter can be configured to use its two analog and/or four relays outputs for process control.

The M300 transmitter is equipped with a USB communication interface. This interface provides real-time data output and instrument configuration capabilities for central monitoring via Personal Computer (PC).

2 Safety instructions

This manual includes safety information with the following designations and formats.

2.1 Definition of equipment and documentation symbols and designations

WARNING: POTENTIAL FOR PERSONAL INJURY.

CAUTION: possible instrument damage or malfunction.



NOTE: Important operating information.



On the transmitter or in this manual text indicates: Caution and/or other possible hazard including risk of electric shock (refer to accompanying documents)

The following is a list of general safety instructions and warnings. Failure to adhere to these instructions can result in damage to the equipment and/or personal injury to the operator.

- The M300 Transmitter should be installed and operated only by personnel familiar with the transmitter and who are qualified for such work.
- The M300 Transmitter must only be operated under the specified operating conditions (see section 8).
- Repair of the M300 Transmitter must be performed by authorized, trained personnel only.
- With the exception of routine maintenance, cleaning procedures or fuse replacement, as described in this manual, the M300 Transmitter must not be tampered with or altered in any manner.
- Mettler-Toledo accepts no responsibility for damage caused by unauthorized modifications to the transmitter.
- Follow all warnings, cautions, and instructions indicated on and supplied with this product.
- Install equipment as specified in this instruction manual. Follow appropriate local and national codes.
- Protective covers must be in place at all times during normal operation.
- If this equipment is used in a manner not specified by the manufacturer, the protection provided by it against hazards may be impaired.

WARNINGS:

Installation of cable connections and servicing of this product require access to shock hazard voltage levels. Main power and relay contacts wired to separate power source must be disconnected before servicing. Main power must employ a switch or circuit breaker as the disconnecting device for the equipment. Electrical installation must be in accordance with the National Electrical Code and/or any other applicable national or local codes.



RELAY CONTROL ACTION: the M300 transmitter relays will always de-energize on loss of power, equivalent to normal state, regardless of relay state setting for powered operation. Configure any control system using these relays with fail-safe logic accordingly.



PROCESS UPSETS: Because process and safety conditions may depend on consistent operation of this transmitter, provide appropriate means to maintain operation during sensor cleaning, replacement or sensor or instrument calibration.

2.2 Correct disposal of the unit

When the transmitter is finally removed from service, observe all local environmental regulations for proper disposal.

3 Unit overview

M300 models are available in both a 1/4DIN and 1/2DIN case size. The 1/4DIN is a panel-mount only design and the 1/2DIN models provides an integral NEMA 4X/IP65 housing for wall-, pipe- or panel-mount.

3.1 Overview 1/4DIN

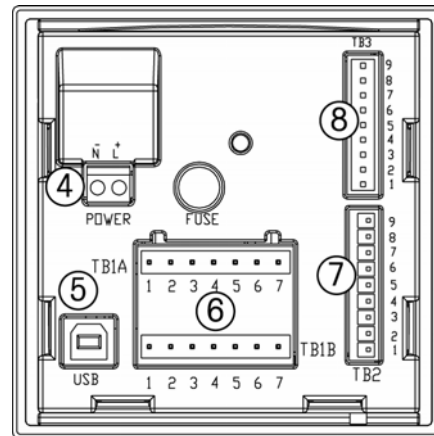
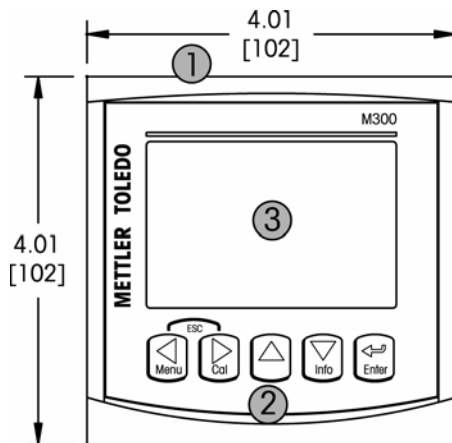

- 1 – Hard Polycarbonate case
- 2 – Five Tactile-Feedback Navigation Keys
- 3 – Four-line LCD Display
- 4 – Power Supply Terminals
- 5 – USB Interface Port
- 6 – Relay Output Terminals
- 7 – Analog Output/Digital Input Terminals
- 8 – Sensor Input Terminals

3.2 Overview 1/2DIN

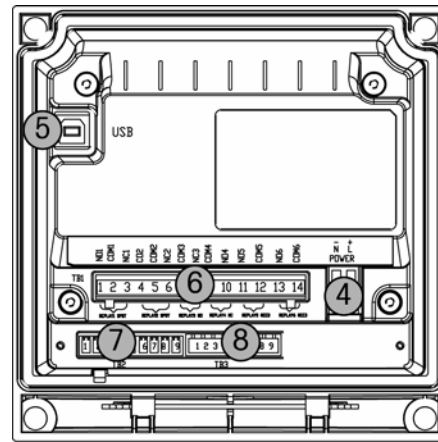
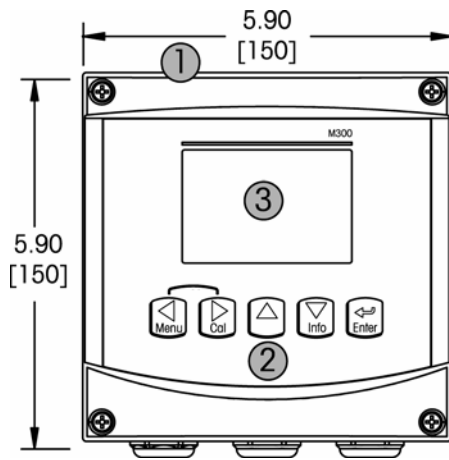

- 1 – Hard Polycarbonate case
- 2 – Five Tactile-Feedback Navigation Keys
- 3 – Four-line LCD Display
- 4 – Power Supply Terminals
- 5 – USB Interface Port
- 6 – Relay Output Terminals
- 7 – Analog Output/Digital Input Terminals
- 8 – Sensor Input Terminals

3.3 Control/navigation keys

3.3.1 Menu structure

Below is the structure of the M300 menu tree:

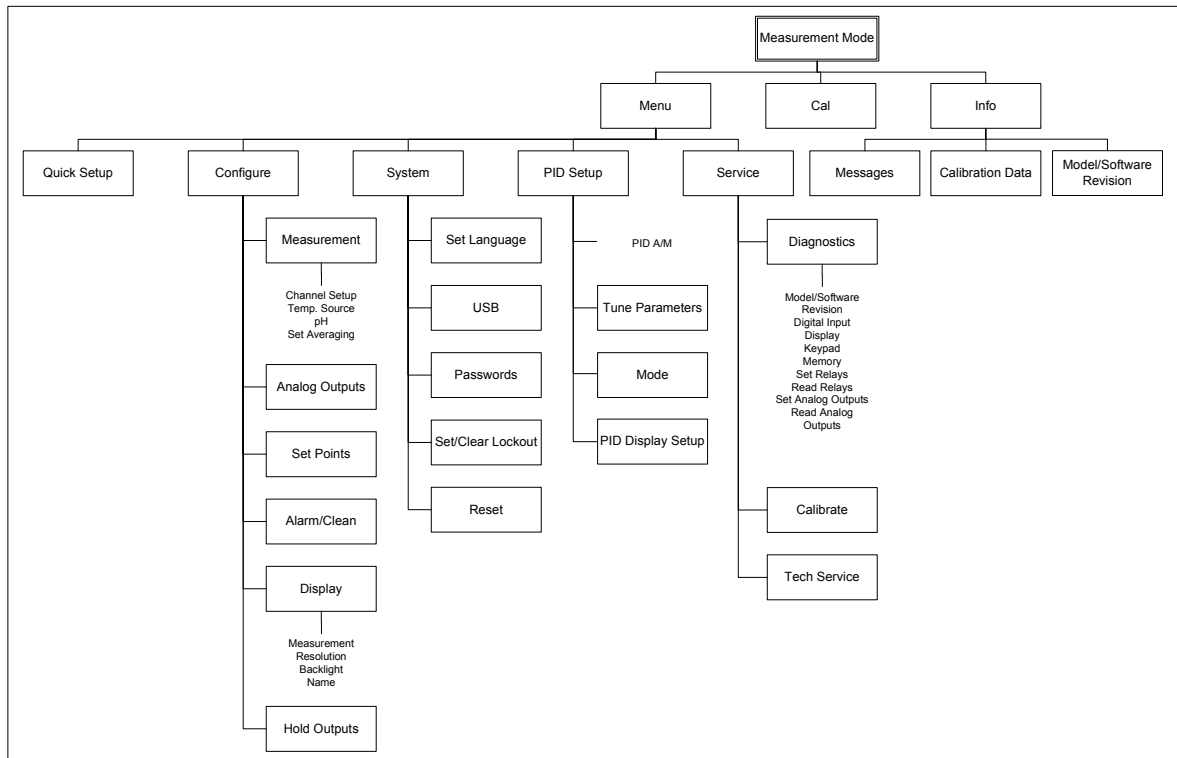

3.3.2 Navigation keys

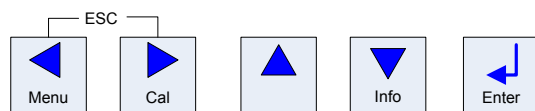



3.3.2.1 Navigating the menu tree

Enter the desired main Menu branch with the Menu, Cal or keys. Use the and Info keys to navigate through the selected Menu branch.



NOTE: In order to back up one menu page, without escaping to the measurement mode, move the cursor under the UP Arrow character at the bottom right of the display screen and press Enter.

3.3.2.2 Escape

Press the  and  key simultaneously (escape) to return to the Measurement mode.

3.3.2.3 Enter

Use the  key to confirm action or selections.

3.3.2.4 Menu

Press the  key to access the main Menu.



3.3.2.5 Calibration mode

Press the  key to enter Calibration Mode.



3.3.2.6 Info mode

Press the  key to enter Info Mode





3.3.3 Navigation of data entry fields

Use the  key to navigate forward or the  key to navigate backwards within the changeable data entry fields of the display.



3.3.4 Entry of data values, selection of data entry options

Use the  key to increase or the  key to decrease a digit. Use the same keys to navigate within a selection of values or options of a data entry field.



NOTE: Some screens require configuring multiple values via the same data field (ex: configuring multiple setpoints). Be sure to use the  or  key to return to the primary field and the  or  key to toggle between all configuration options before entering to the next display screen.

3.3.5 Navigation with ↑ in Display

If a ↑ is displayed on the bottom right hand corner of the display, you can use the  or the  key to navigate to it. If you click [Enter] you will navigate backwards through the menu (go back one screen). This can be a very useful option to move back up the menu tree without having to exit into the measuring mode and re-enter the menu.

3.3.6 "Save changes" dialog

Three options are possible for the "Save changes" dialog: Yes & Exit (Save changes and exit to measuring mode), "Yes & ↑" (Save changes and go back one screen) and "No & Exit" (Don't save changes and exit to measuring mode). The "Yes & ↑" option is very useful if you want to continue configuring without having to re-enter the menu.

3.4 Display



NOTE: In the event of an alarm or other error condition the M300 Transmitter will display a flashing



in the upper right corner of the display. This symbol will remain until the condition that caused it has been cleared.



NOTE: During calibrations with an Analog Output in Hold state, a flashing H will appear in the upper left corner of the display. This symbol will remain for 20 seconds until after the calibration is completed.

4 Installation instruction

4.1 Unpacking and inspection of equipment

Inspect the shipping container. If it is damaged, contact the shipper immediately for instructions. Do not discard the box.

If there is no apparent damage, unpack the container. Be sure all items shown on the packing list are present. If items are missing, notify Mettler-Toledo immediately.

4.1.1 Panel cutout dimensional information - 1/4DIN models

1/4DIN Model transmitters are designed for panel-mount installation only. Each transmitter is supplied with mounting hardware to provide fast and simple installation to a flat panel or flat enclosure door. To insure a good seal and maintain Nema/IP integrity of installation, panel or door must be flat and have a smooth finish. Hardware consists of:

Two – Snap-on Mounting brackets

One – Mounting gasket seal

Transmitter dimensions and mounting shown in figure below.

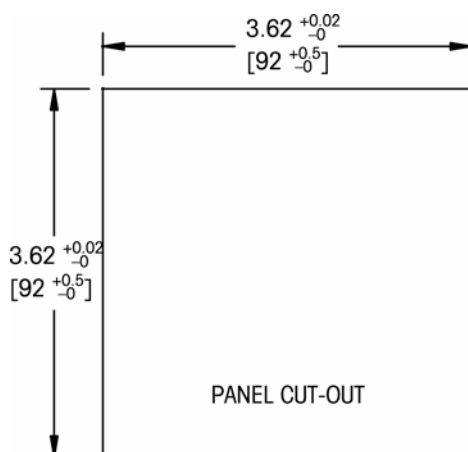

4.1.2 Installation procedure - 1/4DIN models

- Make cutout in panel (see dimensions cutout drawing).
- Be sure surface surrounding cutout is clean, smooth and free of burrs.
- Slide face gasket (supplied with transmitter) around transmitter from the back of the unit.
- Place transmitter into cutout hole. Be sure there are no gaps between the transmitter and panel surface.
- Place the two mounting brackets on either side of the transmitter as shown
- While holding transmitter firmly into the cutout hole, push the mounting brackets toward the backside of panel
- Once secure, use a screwdriver to tighten the brackets against the panel
- Face gasket will compress between transmitter and panel
- Do not overtighten brackets

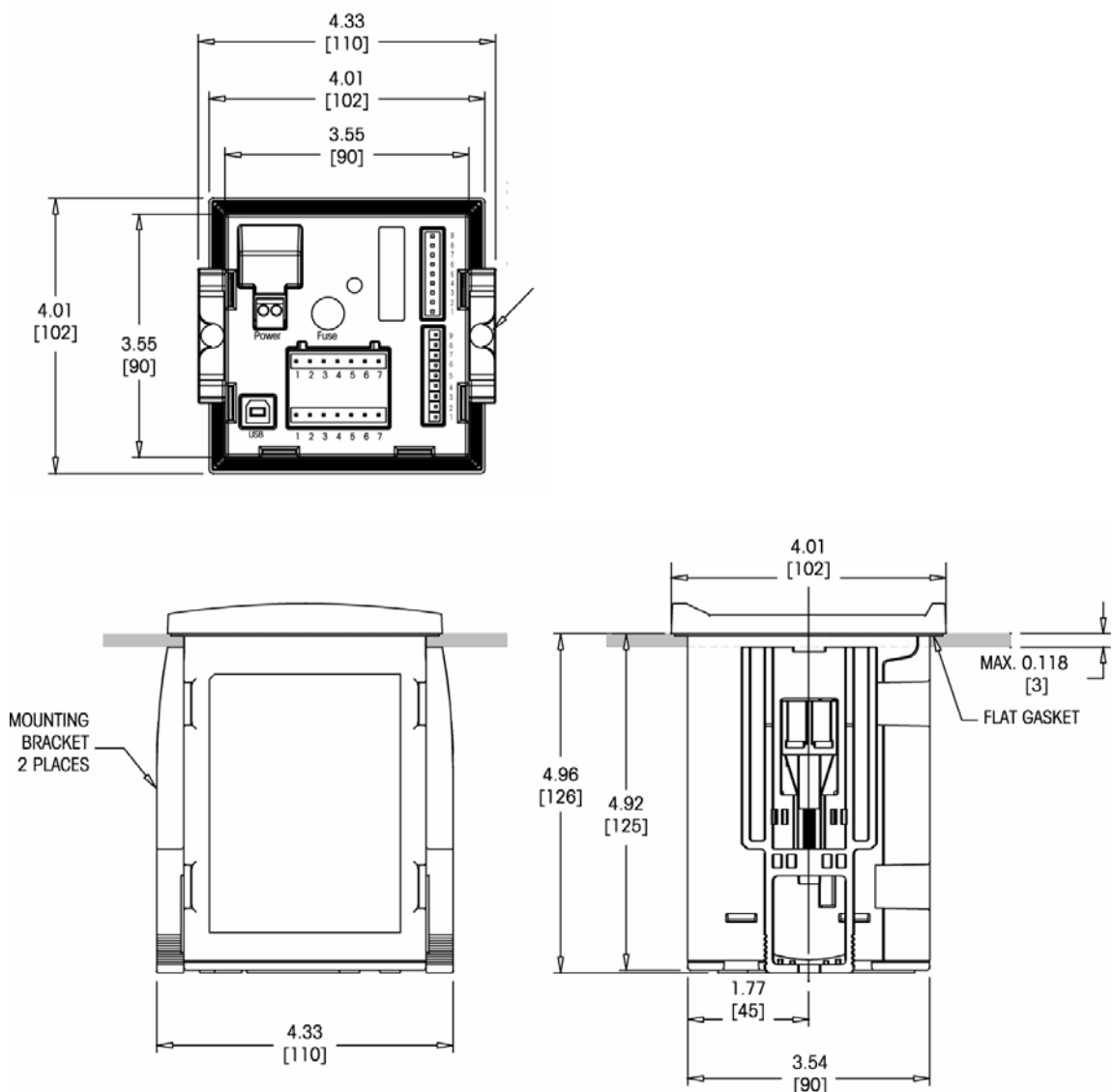

4.1.3 Panel cutout dimensional information - 1/2DIN models

1/2DIN Model transmitters are designed with an integral rear cover for stand-alone wall mount installation. The unit may also be wall mounted using the integral rear cover. See installation instructions in Section 4.1.4.

Below are cut-out dimensions required by the 1/2DIN models when mounted within a flat panel or on a flat enclosure door. This surface must be flat and smooth. Textured or rough surfaces are not recommended and may limit the effectiveness of the gasket seal provided.

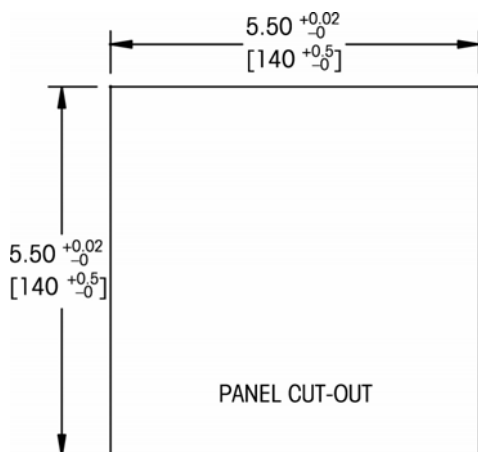

Optional hardware accessories are available that allow for panel- or pipe-mount. Refer to Section 15 for ordering information.

4.1.4 Installation procedure - 1/2DIN models

- Remove rear cover from front housing.
- Start by unscrewing the four screws located on the face of the transmitter, in each corner. This allows the front cover to swing away from the rear housing.
- Remove the hinge-pin by squeezing the pin from each end. This allows the front housing to be removed from the rear housing.
- Drill out wall-mount breakthroughs in the rear housing. This is also a good time to drill out cable gland holes for power, sensor and interface cables.
- Mount rear housing to wall using appropriate mounting hardware for wall surface. Be sure it is level and securely fastened and the installation adheres to any and all clearance dimensions required for transmitter service and maintenance.
- Replace the front housing to the rear housing. The unit is ready to be wired. ∅

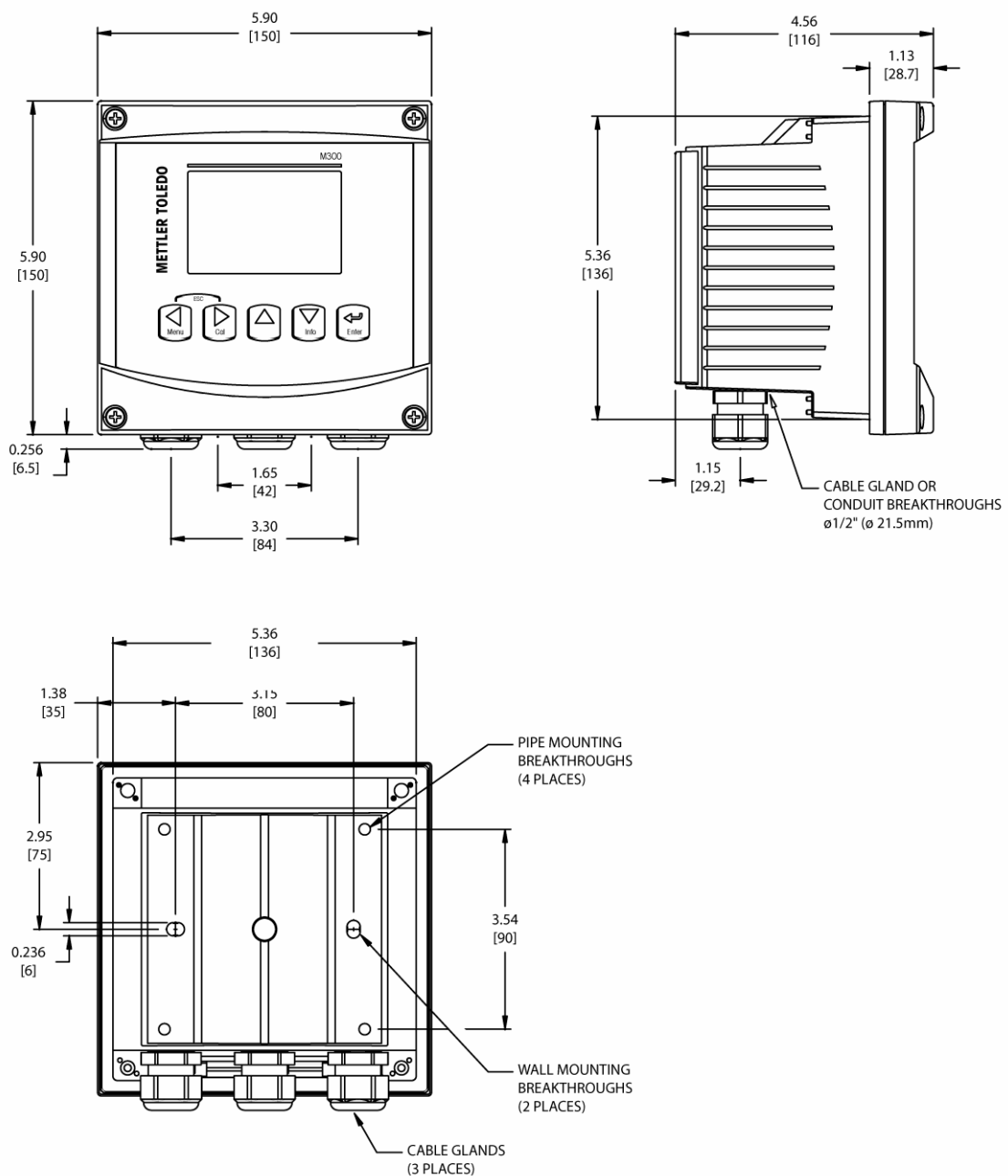

4.2 Connection of power supply

All connections to the transmitter are made on the rear panel of all models.



Be sure power to all wires is turned off before proceeding with the installation. High voltage may be present on the input power wires and relay wires.

A two-terminal connector on the rear panel of all M300 models is provided for power connection. All M300 models are designed to operate from a 20-30 VDC or a 100 to 240 VAC power source. Refer to specifications for power requirements and ratings and size power wiring accordingly.

The terminal block for power connections is labeled "Power" on the rear panel of the transmitter. One terminal is labeled **- N** for the Neutral wire and the other **+L** for the Line (or Load) wire. There is no earth ground terminal on the transmitter. For this reason the internal power wiring within the transmitter is double insulated and the product label designates this using the  symbol.

4.2.1 1/4DIN housing (panel mount)

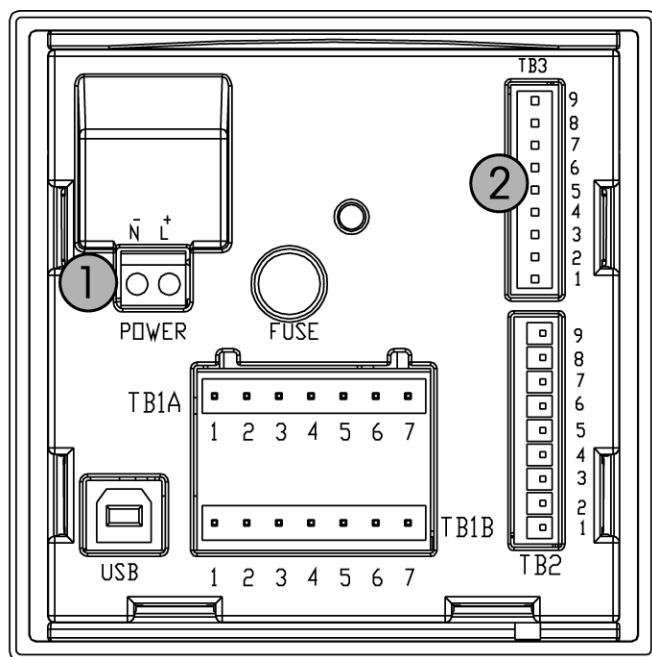

- 1 Connection of power supply
- 2 Terminal for sensor

4.2.2 1/2DIN housing (wall mount)

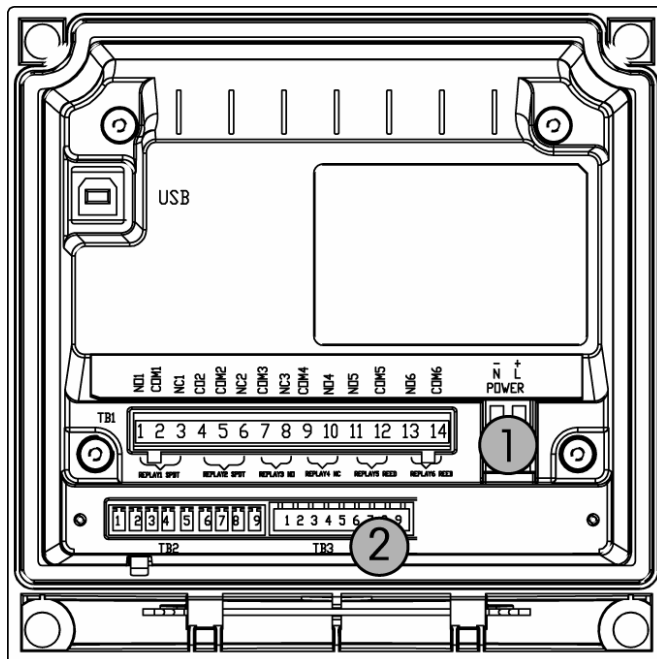

- 1 Connection of power supply
- 2 Terminal for sensor

4.3 Connector PIN definition

4.3.1 TB1 and TB2 for 1/2DIN and 1/4DIN versions

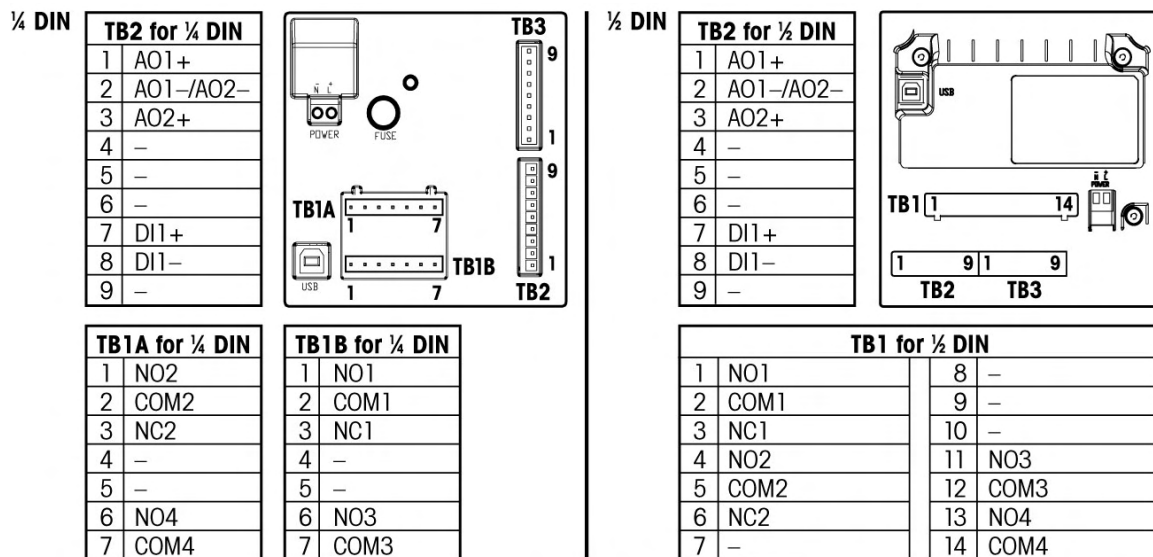

NO=normally open (contact is open if unactuated). NC=normally closed (contact is closed if unactuated).

4.3.2 TB3 for 1/2DIN and 1/4DIN versions

Sensor	Colour	Pin no.	Transmitter
Glass electrode	Coax inner / transparent	1	Glass
		2	not used
Reference electrode	Coax shield / red	3 *	Reference
Outer shield/ Solution GND	Green / yellow blue	4 *	Solution GND/ Shield
		5	not used
RTD return (T1)	white	6	RTD ref/GND
	-	7	RTD sense
RTD in (T2)	Green	8	RTD
		9	+5V
	Grey (don't connect)		





NOTE:

* Install Jumper 3 to 4 when used without Solution Ground

4.4 Connection of sensor

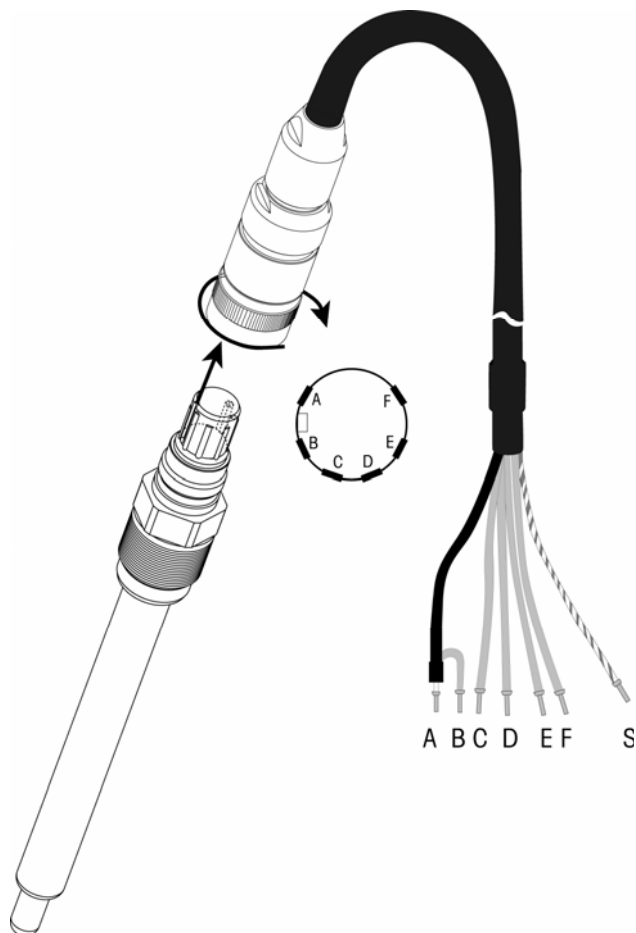
4.4.1 Connecting the sensor to the VP cable



 **NOTE:** Cable lengths > 20 m can worsen the response during pH measurement. Be sure to observe the sensor instruction manual

4.4.2 VP cable assignment

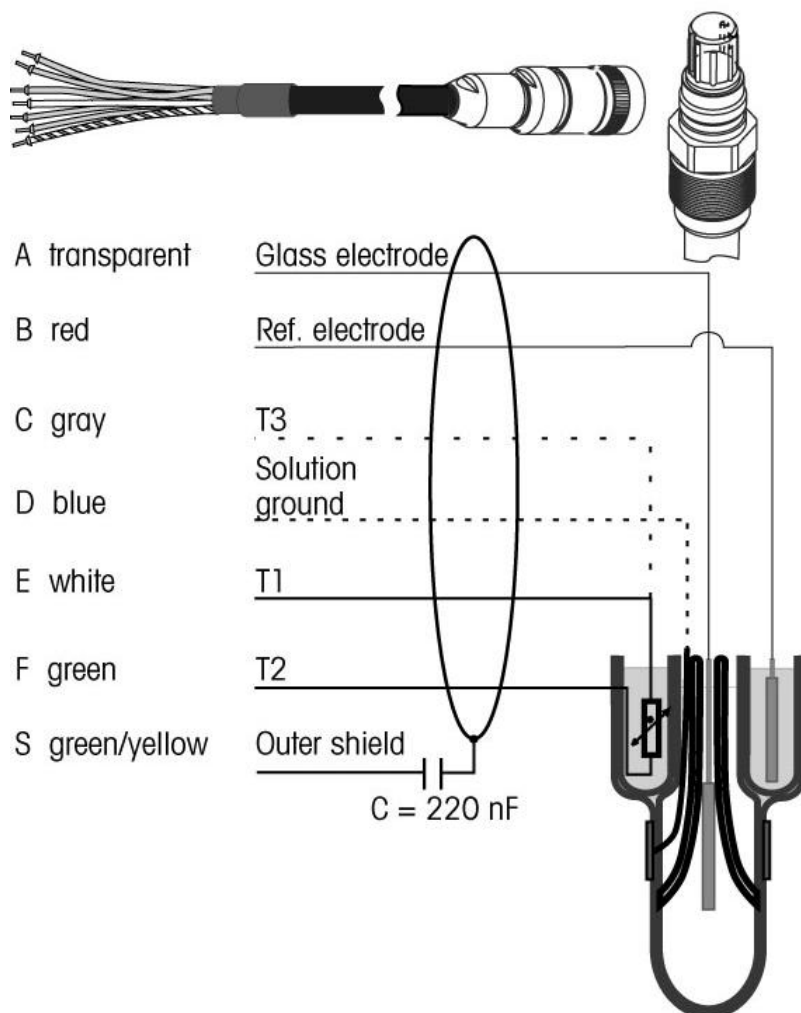

T1/T2 = Temperature probe for 2-wire connection
 T3 = Additional connection for temperature probe (3-wire connection)

4.5 Wiring examples (using TB3)

4.5.1 Example 1 (using TB3)

pH measurement without Solution Ground

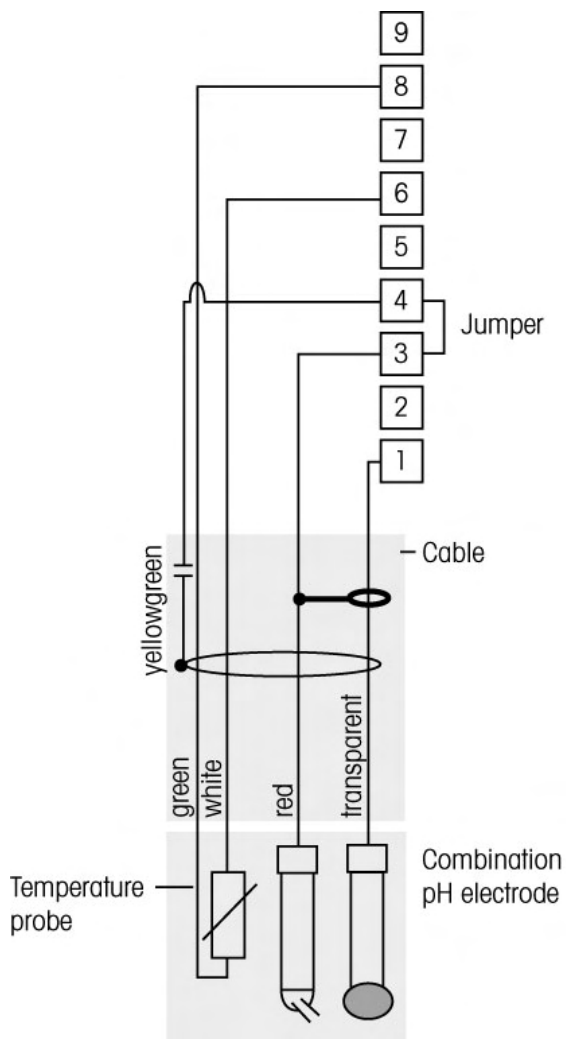

NOTE: Jumper Terminal 3 and 4

Wire colors only valid for connection with VP cable, blue and grey not connected.

- 1 – Glass
- 2 – Not used
- 3 – Reference
- 4 – Shield/GND
- 5 – Not used
- 6 – Solution GND/RTD ref
- 7 – RTD sense
- 8 – RTD ref
- 9 – +5V

4.5.2 Example 2 (using TB3)

pH measurement with Solution Ground

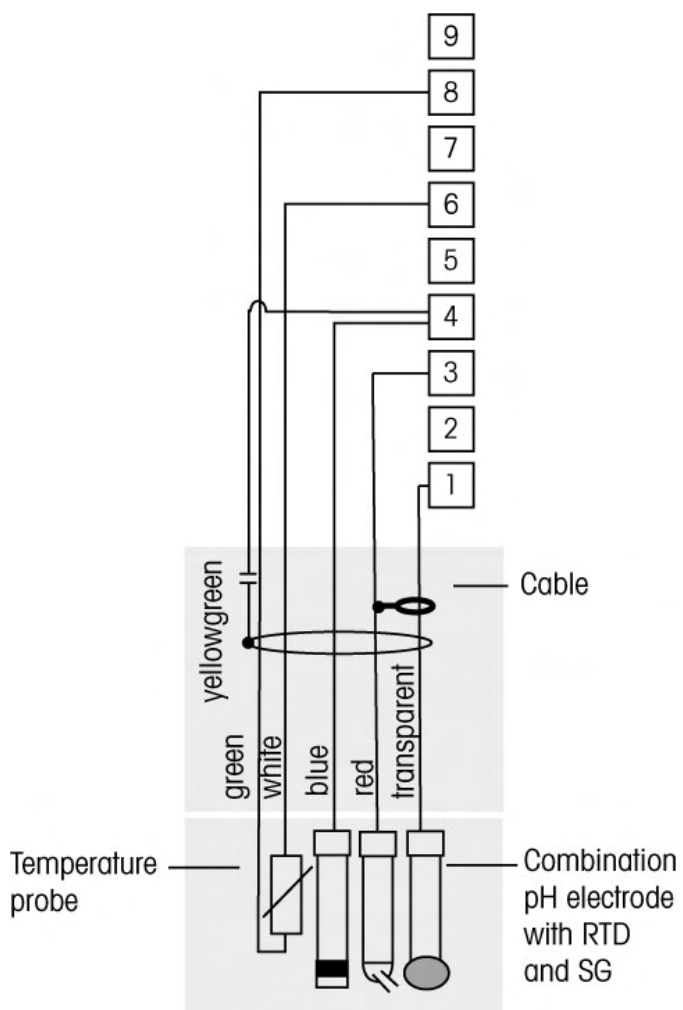

NOTE: Wire colors only valid for connection with VP cable, grey not connected.

- 1 – Glass
- 2 – Not used
- 3 – Reference
- 4 – Shield/GND
- 5 – Not used
- 6 – Solution GND/RTD ref
- 7 – RTD sense
- 8 – RTD ref
- 9 – +5V

4.5.3 Example 3 (using TB3)

ORP measurement

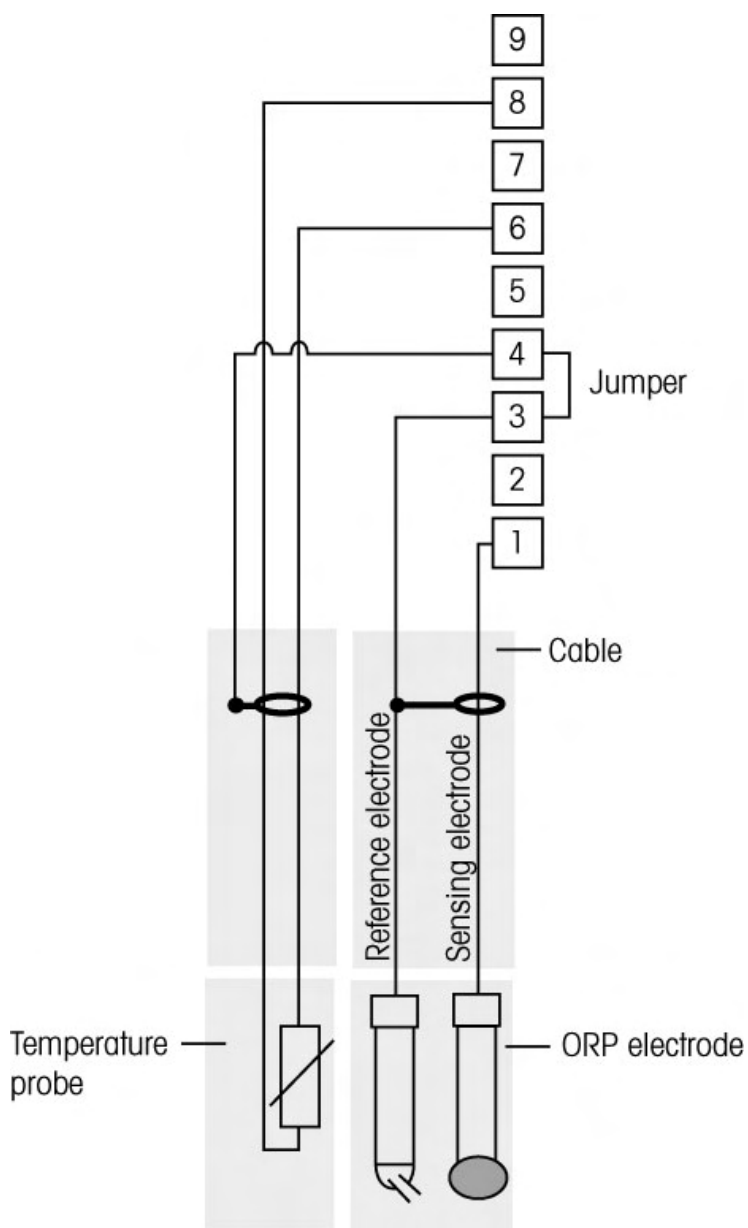

NOTE: Jumper Terminal 3 and 4

- 1 – Glass
- 2 – Not used
- 3 – Reference
- 4 – Shield/GND
- 5 – Not used
- 6 – Solution GND/RTD ref
- 7 – RTD sense
- 8 – RTD ref
- 9 – +5V

4.5.4 Example 4 (using TB3)

ORP measurement with pH Solution ground electrode (e.g. InPro 3250SG, InPro4800SG).

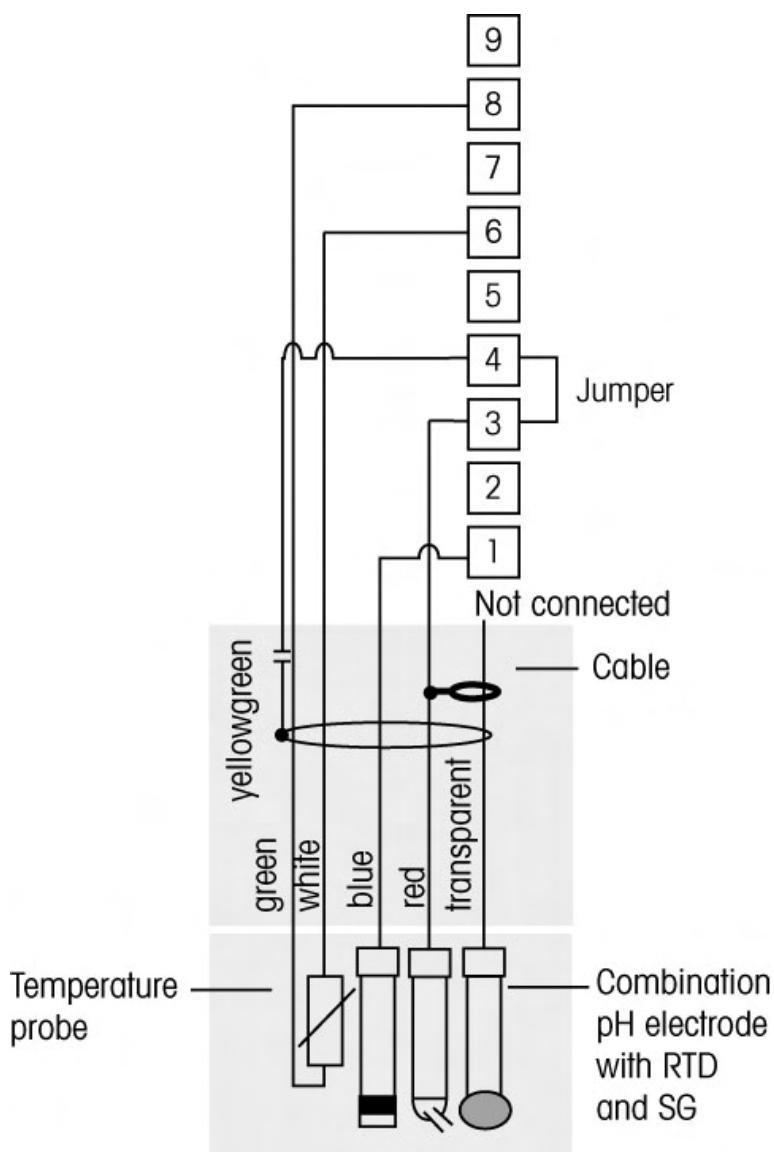

NOTE: Jumper Terminal 3 and 4

- 1 – Glass
- 2 – Not used
- 3 – Reference
- 4 – Shield/GND
- 5 – Not used
- 6 – Solution GND/RTD ref
- 7 – RTD sense
- 8 – RTD ref
- 9 – +5V

5 Placing transmitter in, or out, of service

5.1 Placing transmitter in service



After connecting the transmitter to power supply circuit, it will be active as soon as the circuit is powered.

5.2 Placing transmitter out of service

First disconnect the unit from the main power source, then disconnect all remaining electrical connections. Remove the unit from the wall / panel. Use the installation instruction in this manual as reference for disassembling mounting hardware.

6 Quick setup

(PATH: Menu/Quick Setup)



While in Measurement mode press the [MENU] key to bring up the Menu selection. Select Quick Setup and press the [ENTER] key. The display prompts you to enter the Quick Setup security code. Enter the Quick Setup security code to "xxxxx", then press the [ENTER] key to confirm the Quick Setup security code.

Convention:

- 1st line on display => a
- 2nd line on display => b
- 3rd line on display => c
- 4th line on display => d

Only lines a and b can be configured in Quick setup. Go to the Configuration menu to configure lines c and d.

6.1 Channel selection for the display



Select a or c to configure the values to be displayed. Please use the [Configuration menu](#) to freely configure the channels.

Example:

By selecting a and pH as unit, the pH value will be displayed on the 1st line. By selecting b and pH as unit, the pH value will be displayed on the 2nd line of the display.

By selecting a and °C as unit, the temperature will be displayed on the 1st line. By selecting b and °C as unit, the temperature will be displayed on the 2nd line.

6.2 Analog outputs

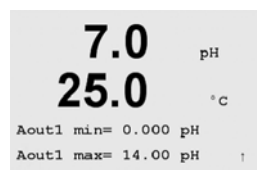

On the same screen above, by selecting Yes the linear 4-20 mA analog output Aout1 will be setup when Enter is pressed. Selecting No means that no analog output is setup.

Aout1 min, Aout1 max are the minimum and maximum measurement values for the 4 and 20 mA values respectively. To configure output 2, use the Configuration Menu. Press [ENTER].

6.3 Set points

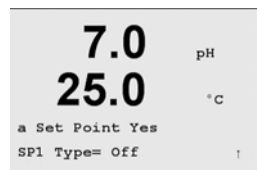

After configuring the Analog Output a Set Point can be configured for that measurement. If No is selected and [ENTER] is pressed then the quick setup is done and the menus are exited without setting up any Setpoint.

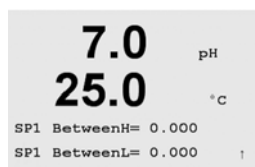

Selecting Yes and pressing [ENTER] means a Setpoint can be configured for channel a. Following Setpoint Types can be selected: High, Low, Between (an alarm is triggered if the measured value is between the specified range), Outside (an alarm is triggered if the measured value is outside the specified range)



After setting the Set point value(s) a Relay (none, 1, 2, 3, 4) can be configured for that Set Point. The Relay delay is set to 10 seconds and the Hysteresis is set to 5%. If a relay is configured as HOLD relay, it will not be selectable in this menu.

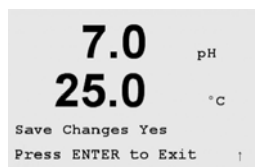



See "Save changes" dialog for options to the Save Changes menu.

7 Calibration

(PATH: Cal)



7.1 Exit calibration mode



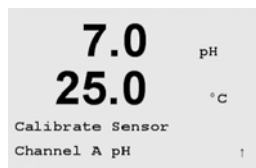

Note: To exit Calibration mode at any time press the  and  key simultaneously (escape). The transmitter returns to the Measurement mode and the old calibration values remain active.

7.2 Enter calibration mode



While in Measurement mode press the  key. The display prompts you to enter the calibration security code. Press the  or  key to set the calibration security code to then press the ENTER key to confirm the calibration security code.

Press the  or  key to select the calibration sub function.

A flashing H in the top left hand corner shows the ongoing calibration process with a Hold condition active.

7.3 pH calibration

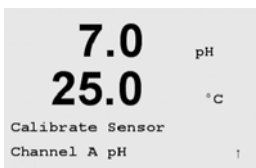

This transmitter unit features one-point, two-point or process calibration with 5 preset buffer sets or manual buffer entry. Buffer values refer to 25 °C. To calibrate the instrument, you need a standard pH buffer solution that matches one of these values.

Enter Calibration mode as described in section 7.2. A flashing H on the top left hand corner of the display indicates that a calibration is in progress

7.3.1 One point calibration

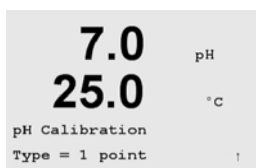

Select 1 point Calibration by pressing the  key followed by the the [ENTER] key.

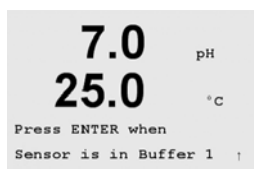

Place the electrode in the buffer solution and press the [ENTER] key to start the calibration.

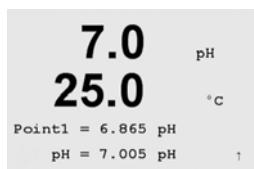

Auto mode: The display shows the buffer that the transmitter has recognized (Point 1) and the measured value.

Manual mode: Enter the buffer value and press [ENTER] to proceed.

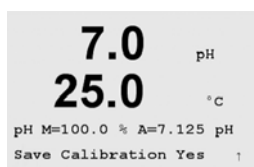

As soon as the drift conditions have been fulfilled (or [ENTER] pressed in manual mode) the display changes to show the slope calibration factor **S** and the offset calibration factor **Z**.

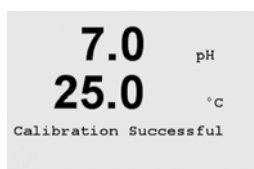

Select Yes to save the calibration values and the successful Calibration is confirmed on the display.

7.3.2 Two point calibration

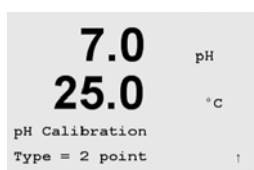

Select 2 point Calibration by pressing the [ENTER] key.

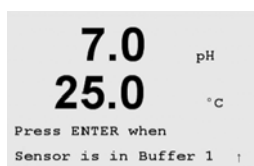

Place the electrode in the first buffer solution and then press the [ENTER] key.

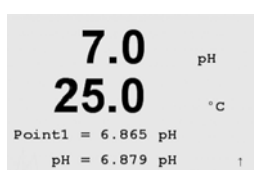

Auto mode: The display shows the buffer that the transmitter has recognized (Point 1) and the measured value.

Manual mode: Enter the buffer value and press [ENTER] to proceed.

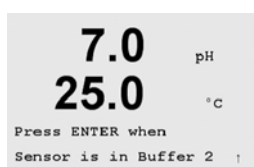

As soon as the drift conditions have been fulfilled (or [ENTER] pressed in manual mode) the display changes and prompts you to place the electrode in the second buffer solution.

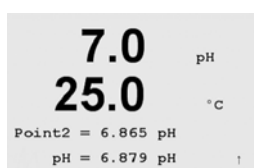

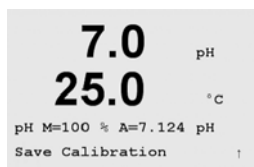

As soon as the drift conditions have been fulfilled (or [ENTER] pressed in manual mode) the display changes to show the slope calibration factor **S** and the offset calibration factor **Z**.



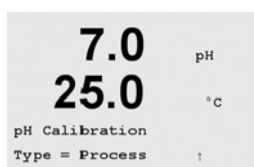

Select Yes to save the calibration values and the successful Calibration is confirmed on the display.



7.3.3 Process calibration

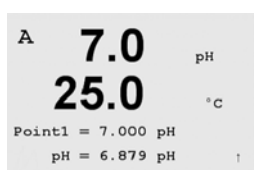

Select Process Calibration by pressing the  once followed by the [ENTER] key. Take a sample and press the [ENTER] key again to store the current measuring Value. To show the ongoing Calibration Process an A is displayed in the top left hand corner.



After determining the pH Value of the Sample press the  key again to proceed with the calibration. The display prompts you to enter the calibration security code.

Press the  or  key to set the calibration security code to "xxxxx", then press the ENTER key to confirm the calibration security code.

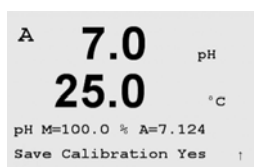

Enter the pH value of the sample then press the [ENTER] key to start calibration.

After the calibration the slope calibration factor S and the offset calibration factor Z are displayed. Select Yes to save the new calibration values and the successful Calibration is confirmed on the display. The H in the top left hand corner disappears after 20seconds.

7.4 mV calibration



Enter Calibration mode as described in section 7.2. and select mV Calibration.

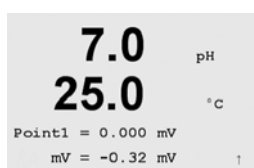

The user can now enter Point 1 The offset calibration factor is calculated as: Point1 + mV (measured value) and displayed on the next screen.

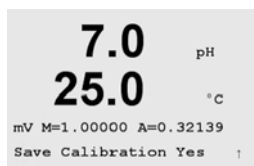

Z is the newly calculated offset calibration factor. The slope calibration factor S is always 1 and does not enter the calculation.

Select Yes to save the new calibration values and the successful Calibration is confirmed on the display.

7.5 Temperature calibration

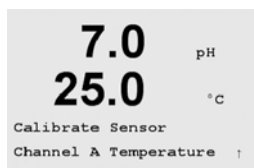

Enter Calibration mode as described in section 7.2. and select Temperature Calibration.

7.5.1 One-point temperature calibration

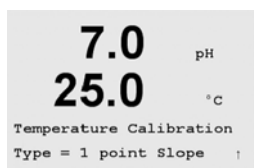

See 7.5 on how to enter the Temperature Calibration menu. Slope or Offset can be selected with the 1 point calibration. Select Slope to recalculate the Slope factor M and Offset to recalculate the offset calibration factor A.

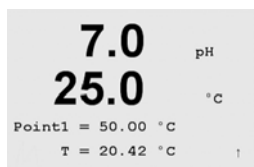

Enter Point 1

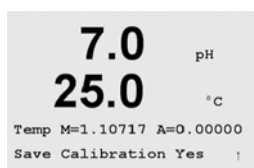

The newly calculated value – either M or A – is displayed. Select Yes to save the new calibration values and the successful Calibration is confirmed on the display.

7.5.2 Two-point temperature calibration

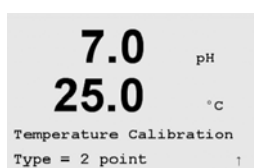

See 7.5 on how to enter the Temperature Calibration menu. Select 2 point as calibration Type.

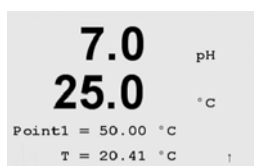

Enter the value for Point 1 and press [ENTER].

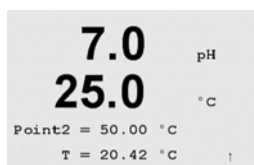

Enter the value for Point 2 and press [ENTER].

```

7.0    pH
25.0   °C
Temp M=0.00000 A=1193.94
Save Calibration Yes  ↑

```

The newly calculated values M and A are displayed. Select Yes to save the new calibration values and the successful Calibration is confirmed on the display.

7.6 Edit pH

```

7.0    pH
25.0   °C
Calibrate Sensor
Channel A Edit pH  ↑

```

Enter Calibration mode as described in section 7.2. and select Edit pH.

```

7.0    pH
25.0   °C
p M=100.0 % A=7.124 pH
s M=1.0000 A=1.587  ↑

```

All calibration constants of the primary measurement (p) for the sensor are displayed on Line 3. All calibration constants of the secondary measurement (s) for the sensor are displayed on Line 4. The calibration constants can be changed in this menu.

```

7.0    pH
25.0   °C
Save Calibration Yes
Press ENTER to Exit  ↑

```

Select Yes to save the new calibration values and the successful Calibration is confirmed on the display.

7.7 Edit mV

```

7.0    pH
25.0   °C
Calibrate Sensor
Channel A Edit mV  ↑

```

Enter Calibration mode as described in section 7.2. and select Edit mV.

```

7.0    pH
25.0   °C
p M=1.0000 A=0.0000
s M=1.0000 A=1.1587  ↑

```

All calibration constants of the primary measurement (p) for the sensor are displayed on Line 3. All calibration constants of the secondary measurement (s) for the sensor are displayed on Line 4. The calibration constants can be changed in this menu.

```

7.0    pH
25.0   °C
Save Calibration Yes
Press ENTER to Exit  ↑

```

Select Yes to save the new calibration values and the successful Calibration is confirmed on the display

7.8 Verify



Enter Calibration mode as described in section 7.2. and select Verify.

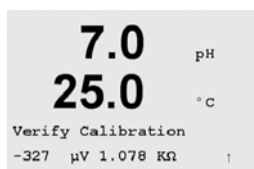

The value of the primary measurement (mV for a pH or ORP sensor) and the value of the secondary measurement (resistance of the temperature sensor for all sensors except ORP) are shown. The meter calibration factors are used when calculating these values.

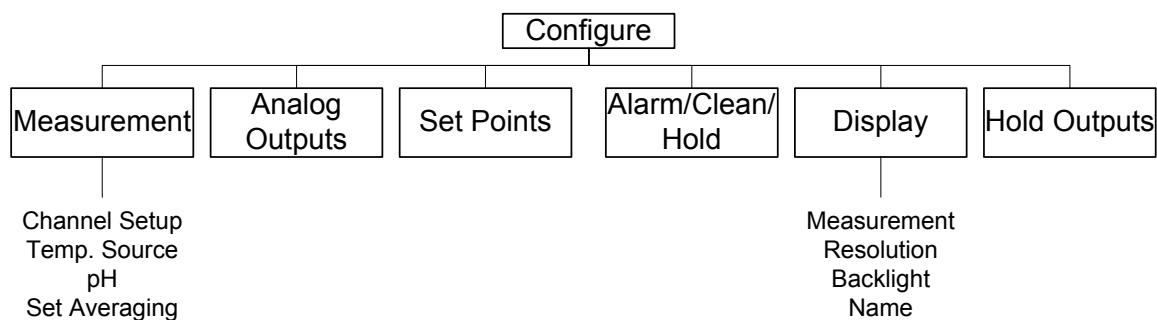

8 Configure

(PATH: Menu/Configure)





8.1 Exit configuration mode



NOTE: to exit Configuration mode at any time press the  and  key simultaneously (escape). The transmitter returns to the Measurement mode and the old settings remain active.

8.2 Enter configuration mode



While in Measurement mode press the  key. Press the  or  key to navigate to the Configure – Menu. After selecting the Configure – Menu enter the configuration security code and then press the [ENTER] key to confirm the code.

8.3 Measurement

(Menu/Configure/Measurement)



Press the [ENTER] key to select this Menu. Following sub menus can now be selected: Channel Setup, Temperature Source, pH and Set Averaging.

8.3.1 Channel setup

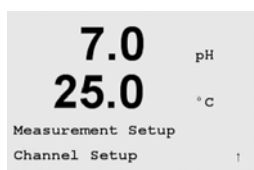

Press the [ENTER] key to select this Menu.



The 4 lines of the display can now be configured with a value. Pressing the [ENTER] key will display the selection for lines c and d.

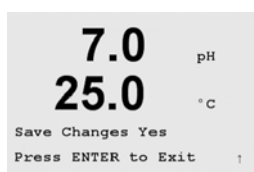

Pressing the [ENTER] key again will bring up the Save Changes dialog. Selecting 'No' will discard the entered values and return to the measurement display screen, selecting 'Yes' will save changes made.

8.3.2 Temperature source

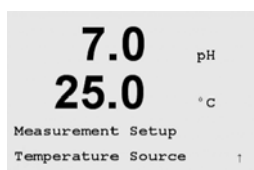

Press the [ENTER] key to select this Menu. The following options can be chosen:
 Fixed or Use this channel
 Fixed: allows a specific temperature value to be entered.
 Use this channel: temperature input will be taken from the sensor attached.

8.3.3 pH



Press the [ENTER] key to select this Menu, which allows for the setting of additional measurement and calibration parameters for the pH sensor.

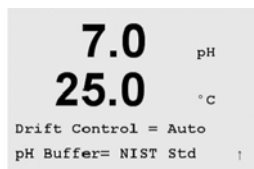

Drift control can be chosen as Auto (drift and time criteria have to be fulfilled) or Manual (The user can decide when a signal is stable enough) and the relevant buffer table for the automatic buffer recognition can be selected.

If the drift value is less than 0.4 mV over a 20second interval then the reading is stable and the calibration is done using the last reading.

If the drift criteria is not met within 300 seconds then the calibration times out and the message "Calibration Unsuccessful Press Enter to Continue" is displayed.

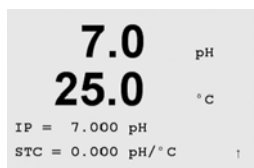

IP is the isothermal point value (Default = 7.000)

STC is the solution temperature compensation factor (Default = 0.000)



Selecting No means the Temperature configured under 8.3.2 will be used for the Calibration. Selection Yes gives the user the Option to enter a fixed Calibration Temperature.

8.3.4 Set averaging

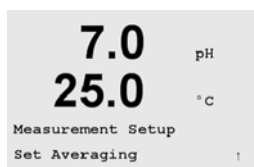

Press the [ENTER] key to select this Menu. The averaging method (noise filter) for each channel can now be selected. The options are Special (Default), None, Low, Medium and High:

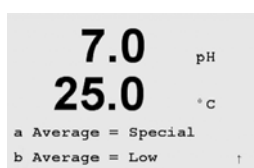

None = no averaging or filtering
 Low = equivalent to a 3 point moving average
 Medium = equivalent to a 5 point moving average
 High = equivalent to a 7 point moving average
 Special = averaging depending on signal change (normally High averaging but Low averaging for large changes in input signal)

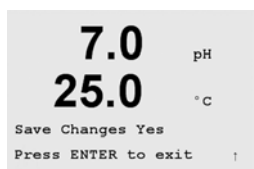

Pressing the [ENTER] key again will bring up the Save Changes dialog. Selecting No will discard the entered values and return to the measurement display screen, selecting Yes will save changes made.

8.4 Analog outputs

(PATH: Menu/Configure/Analog Outputs)



Press the [ENTER] key to select this Menu, which lets you configure the 2 Analog Outputs.

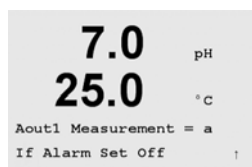

The analog output number (default is 1), the channel (a, b, c, d or blank (none)) and a value (off, 3.6 mA or 22.0 mA. default is off) are configured. If a mA value is, the value of the analog output will go to the set value if any of the alarm conditions occur

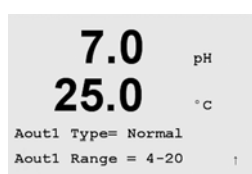

The Aout type can be Normal, Bi-Linear, Auto-Range or Logarithmic. The range can be 4-20mA or 0-20mA. Normal provides linear scaling between the minimum and maximum scaling limits and is the default setting. Bi-Linear will also prompt for a scaling value for the mid-point of the signal and allows two different linear segments between the minimum and maximum scaling limits.



Enter the minimum and maximum Value of Aout.

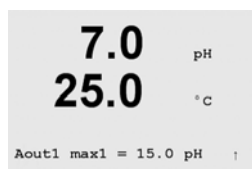

If Auto-range was selected as Type then Aout max can be configured. Aout max is the maximum value for the first range on Auto-Range. The maximum value for the second range on Auto-Range was set in the previous menu. If Logarithmic Range was selected, it will also prompt for the number of decades as 'Aout1 # of Decades = 2'.



The value for the Hold mode can be configured to hold the last value or can be set to a Fixed value.

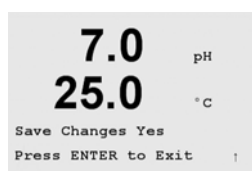

Pressing the [ENTER] key again will bring up the Save Changes dialog.

8.5 Set points

(PATH: Menu/Configure/Set Points)

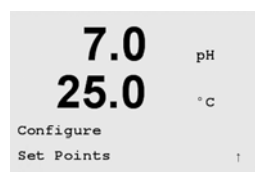

Press the [ENTER] key to select this Menu.

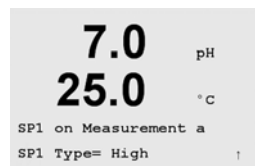

Up to 4 Set Points can be configured on any of the channels (a thru d). Possible types are Off, High, Low, Outside and Between.

An 'Outside' Setpoint will cause an alarm condition whenever the measurement goes above its high limit or below its low limit. A 'Between' Setpoint will cause an alarm condition to occur whenever the measurement is between its high and low limits.



Enter the desired value(s) for the Set Point

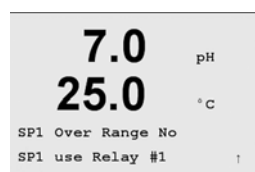

This screen provides the option to configure a setpoint to be active on an over range condition. Select the setpoint (1 thru 4) and 'Yes' or 'No'. Select the desired relay that will activate when the setpoint alarm condition is reached.

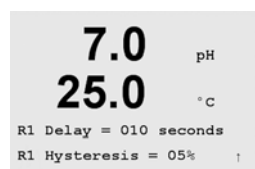

Set the Relay delay and the Hysteresis of the configured Relay.

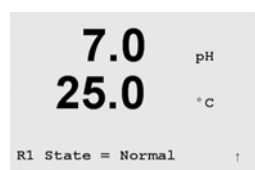

Set the type of Relay contact, either normal or inverted.

Pressing the [ENTER] key again will bring up the Save Changes dialog. Selecting No will discard the entered values, selecting Yes will make the entered values the current ones.

8.6 Alarm/Clean

(PATH: Menu/Configure/Alarm/Clean)



This Menu allows the configuration of Alarm and Clean functionality.

8.6.1 Alarm



Select the Relay to be used for the Alarm.

Select one of the following events to be alarmed:

1. Power failure
2. Software failure
3. Rg Diagnostics
4. Rr Diagnostics.

If any of these are set to yes then the alarm will come on and an alarm message will be recorded if:

1. there is a power failure or power cycling
2. the software watchdog performs a reset
3. Rg is out of tolerance
4. Rr is out of tolerance



For 1 and 2 the alarm indicator will be turned off when the alarm message is cleared. They will reappear if the power is constantly cycling or if the watchdog is repeatedly resetting the system.

For 3 and 4 the alarm indicator will go off if the message is cleared and the sensor has been replaced or repaired so that the Rg and Rr values are within specification. If the Rg or Rr message is cleared and Rg or Rr is still out of tolerance then the alarm will stay on and the message will reappear. The Rg and Rr alarm can be turned off by going into this menu and setting Rg Diagnostics and/or Rr Diagnostics to no. The message can then be cleared and the alarm indicator will be off even though Rg or Rr is out of tolerance.

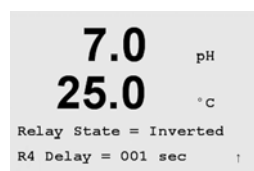

Configure the chosen Alarm Relay. The state can be Normal or Inverted, also a Delay for the activation can be set.

Pressing the [ENTER] key again will bring up the Save Changes dialog. Selecting No will discard the entered values, selecting Yes will make the entered values the current ones.

8.6.2 Clean

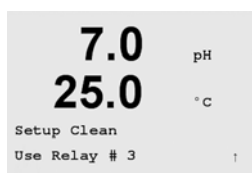

Configure the Relay to be used for the cleaning cycle.

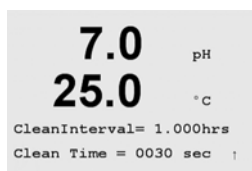

The Cleaning Interval can be set from 0.000 to 999.9 hours. Setting it to 0 turns the clean cycle is off. The cleaning time can be 0 to 9999 seconds and must be smaller than the Cleaning Interval.

Select the desired Relay state: Normal or Inverted.

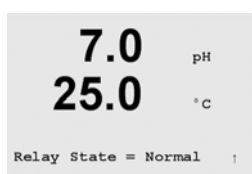

Pressing the [ENTER] key again will bring up the Save Changes dialog. Selecting No will discard the entered values, selecting Yes will make the entered values the current ones.

8.7 Display

(PATH: Menu/Configure/Display)



This Menu allows for the configuration of the values to be displayed and also the configuration of the Display itself.

8.7.1 Measurement



The Display has 4 lines. Line 1 on top and line 4 on the bottom.

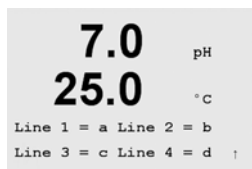

Select the values (channels) to be displayed on each line of the display.



If this is set to On then when an alarm occurs the message "Failure – Press Enter" will be on Line 4 in the normal measurement mode.

Pressing the [ENTER] key again will bring up the Save Changes dialog.

8.7.2 Resolution



This menu allows the setting of the resolution of each displayed values.

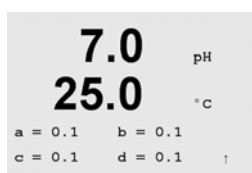

Possible settings are 1, 0.1, 0.01, 0.001 or Auto.

Pressing the [ENTER] key again will bring up the Save Changes dialog.

8.7.3 Backlight



This Menu allows the setting of the back light options of the display.



Possible settings are On, On 50% or Auto Off 50%. If Auto Off 50% is selected then the backlight will go to 50% after 4 minutes with no keypad activity. The backlight will automatically come back on if a key is pressed.

Pressing the [ENTER] key again will bring up the Save Changes dialog.

8.7.4 Name



This menu allows for the configuration of a text which is displayed on Lines 3 and 4 of the Display.

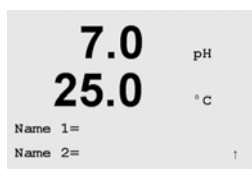

The Name can be alphanumeric and is displayed in the last 9 characters of Line 3 and Line 4 during normal measurement mode. The default is nothing (blank).

8.8 Hold outputs

(PATH: Menu/Configure/Hold Outputs)

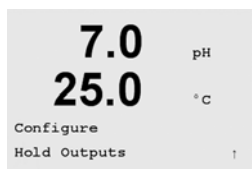

This Menu allows for the configuration of the Hold status. The HOLD function is used if a Easy Clean system is controlled from the M300 or if a control of the HOLD functionality is required from an overlying system.

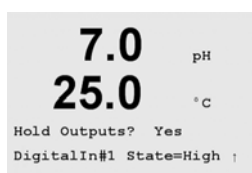



Analog outputs will not be held if No is selected. If Yes is selected, Outputs will be held depending of the status of Digital Input # 1. The choices are 'high' or 'low'. All outputs will be held if the digital input is in the selected state. If 'Off' is selected as DI (Digital Input) status, the Digital Input is inactive and the Hold status will not be triggered through an external signal, although the outputs will be held during configuration or calibration procedures as long as the hold Outputs option is 'Yes'.

9 System

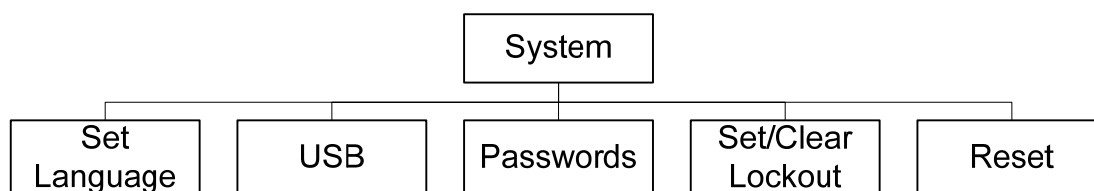
(PATH: Menu/System)



While in Measurement mode press the  key. Press the  or  key to navigate to the System – Menu. After selecting the System – Menu enter the System security code and then press the [ENTER] key to confirm the code.

9.1 Set language

(PATH: Menu/System/Set Language)

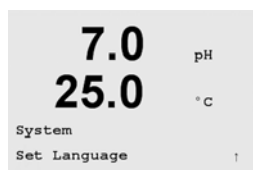

This Menu allows the configuration of the Display language.

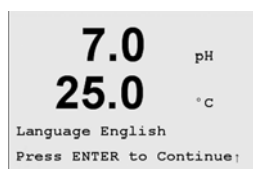

Following selections are possible: English, French, German, Italian and Spanish.

Pressing the [ENTER] key will bring up the Save Changes dialog. Selecting No will discard the entered value, selecting Yes will make the entered value the current one.

9.2 USB

(PATH: Menu/System/USB)



This menu allows for the configuration of the USB port



USB Hold can be set to OFF or Last Values. This allows the user to select whether or not the USB output will hold the Last value, or continue to output the current value during a Hold Outputs condition.

9.3 Passwords

(PATH: Menu/System/Passwords)

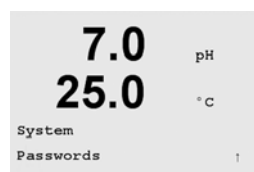

This Menu allows for the configuration of Operator and Administrator Passwords, as well as setting up a List of allowed Menus for the Operator. The Administrator has rights to access all Menus. The default passwords are 00000 for Administrator and Operator.

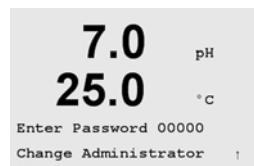

The Passwords Menu is protected: Enter the Administrator Password to enter the Menu.

9.3.1 Changing passwords

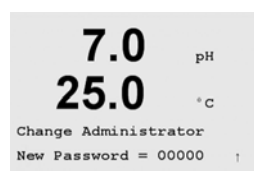

See 9.3 on how to enter the Passwords Menu. Then select Change Administrator or Change Operator to change the appropriate Password and set the new Password. Pressing the [ENTER] key will bring up the Save Changes dialog. Selecting No will discard the entered Password, selecting Yes will make the entered Password the current one.

9.3.2 Configuring menu access for operator

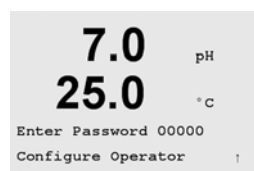

See 9.3 on how to enter the Passwords Menu. Then select Configure Operator to configure the Access list for the Operator. It is possible to assign/deny rights to the following Menus:

Cal Key, Configuration, System, PID Setup and Service. Choose either Yes or No to give/ deny access to the above Menu Menus and press [ENTER] to advance to the next items. Pressing the [ENTER] key after configuring all menus will bring up the Save Changes dialog. Selecting No will discard the entered values, selecting Yes will make the entered values the current ones.

9.4 Set/clear lockout

(PATH: Menu/System/Set/Clear Lockout)

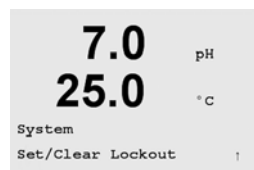

The user will be asked for a password before being allowed into any menus if the Lockout functionality is enabled.

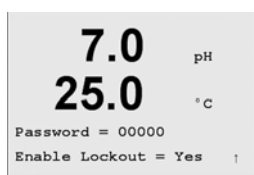

The Lockout – Menu is protected: Enter the Administrator Password and select YES to enable or NO to disable the Lockout functionality. Pressing the [ENTER] key after the selection will bring up the Save Changes dialog.

9.5 Reset

(PATH: Menu/System/Reset)

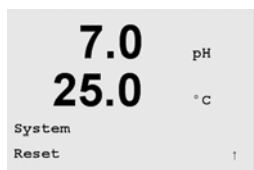

This Menu allows for following options:
Reset System, Reset Meter Cal, Reset Analog Cal.

9.5.1 Reset system

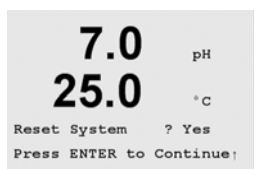

This Menu allows the reset of the meter to the factory default settings (see [Default tables](#)). The meter calibration and the analog output calibration are not affected.

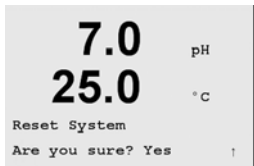

Pressing the [ENTER] key after the selection will bring up a confirmation screen. Selecting No will discard the entered value, selecting Yes will make the entered value the current one.

9.5.2 Reset meter calibration

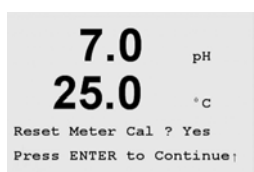

This Menu allows the reset of the meter's calibration factors to the last factory calibration values.

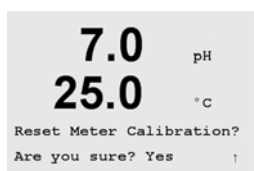

Pressing the [ENTER] key after the selection will bring up a confirmation screen. Selecting No will discard the entered value, selecting Yes will make the entered value the current one.

9.5.3 Reset analog calibration

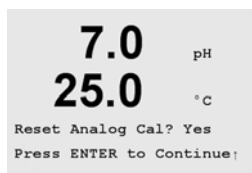

This Menu allows the reset of the Analog Output calibration factors to the last factory calibration values.

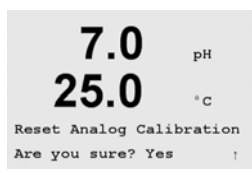

Pressing the [ENTER] key after the selection will bring up a confirmation screen. Selecting No will discard the entered value, selecting Yes will make the entered value the current one.

10 PID setup

(PATH: Menu/PID Setup)

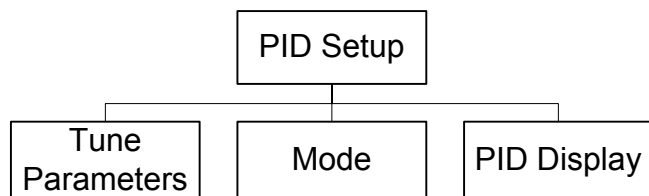

PID control is proportional, integral and derivative control action that can provide smooth regulation of a process. Before configuring the transmitter, the following process characteristics must be identified.

Identify the **reagent requirements** of the process:

- Acid feed only—increasing measurement produces increasing control output, also for ORP reducing reagent feed
- Base feed only—increasing measurement produces decreasing control output, also for ORP oxidizing reagent feed
- Both acid and base feed

Identify the **control output type** based on the control device(s) to be used (both control devices must have the same type of control output type):

- Pulse Frequency—used with pulse input metering pumps
- Pulse Length—used with solenoid valves
- Analog—used with current input devices such as electric drive units, analog input metering pumps or current-to-pneumatic (I/P) converters for pneumatic control valves

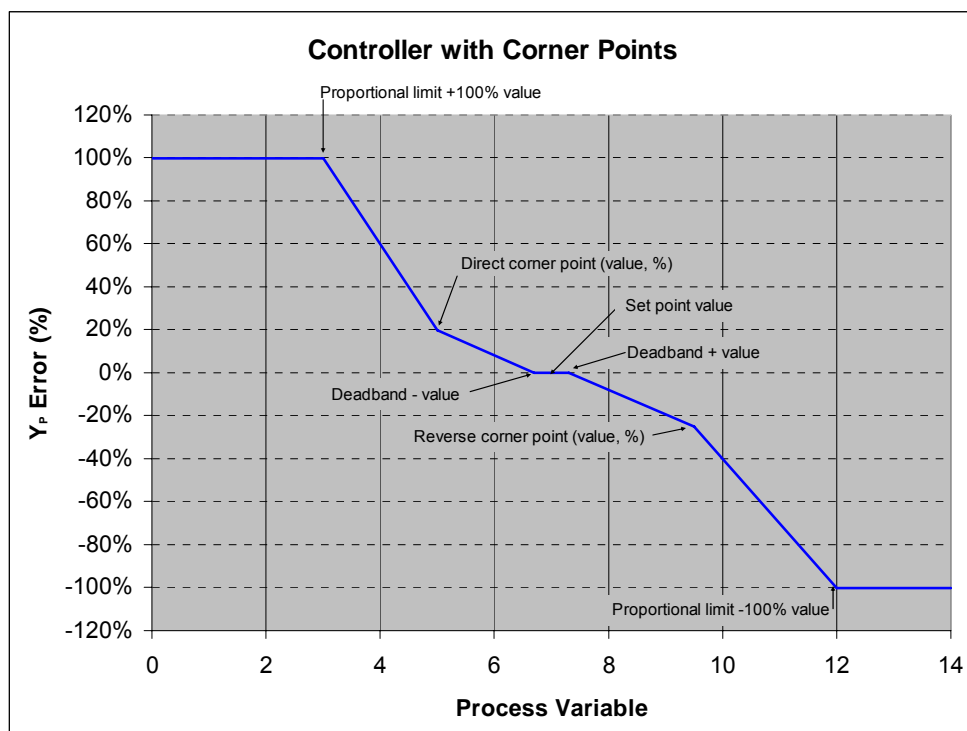

Default control settings provide linear control. If desired, identify the **non-linearity** of the process. Improved control can be obtained if the non-linearity is accommodated with an opposing non-linearity in the controller. A titration curve (graph of pH or ORP vs. reagent volume) made on a process sample provides the best information. There is often a very high process gain or sensitivity near the setpoint and decreasing gain further away from the setpoint.

To counteract this, the instrument allows for adjustable non-linear control with settings of a deadband around the setpoint, corner points further out and proportional limits at the ends of control as shown in the figure below. Determine the appropriate settings for each of these control parameters based on the shape of the process titration curve.



10.1 Enter PID setup



While in Measurement mode press the  key. Press the  or  key to navigate to the PID Setup – Menu. After selecting the PID Setup – Menu enter the System security code “xxxxx” and then press the [ENTER] key to confirm the code.

10.2 PID A/M

(Path MENU/PID Setup/PID A/M)

Select Auto or Manual as an operation mode. Running the PID controller in Auto means the M300 does the controlling of the outputs. Running in Manual mode allows for manual control of the outputs.

In Manual, the control output may be adjusted with the up and down arrow keys. (The “Info” key function is not available in Manual.)

10.3 Mode

(Path MENU/PID Setup/Mode)



This menu contains the selection of control modes using relays or analog outputs. Press [ENTER].

Relay(s) or analog output(s) for PID control action as well as details of their operation can be assigned. Based on the control device being used, select one of the following three paragraphs for solenoid valve, pulse input metering pump or analog control.

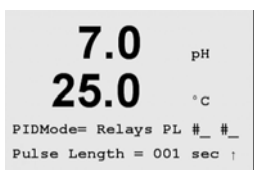

If using a solenoid valve, use the Pulse Length relay selection shown in the first screen. Choose the first relay position as #1 if feeding base. Choose the second relay position as #2 if feeding acid. Set the pulse length (reagent addition cycle time) in seconds. A short pulse length will provide more uniform addition of reagent. A longer pulse length will reduce wear on the solenoid valve. A value of 10 seconds may be a good starting point. The % "on" time in the cycle is proportional to the control output.

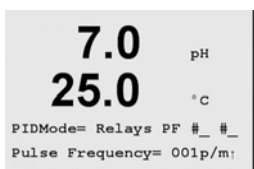

If using a pulse input metering pump, change "Pulse Length" to "Pulse Frequency" as shown. Choose the first relay position as #3 if feeding base. Choose the second relay position as #4 if feeding acid. Set the pulse frequency to the maximum frequency allowed for the particular pump(s) being used, typically 60 to 100 pulses/minute.

Control action will produce this frequency at 100% output.



CAUTION: Setting the Pulse Frequency too high may cause the pump to overheat.

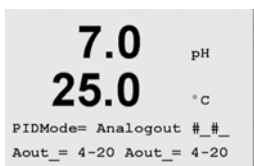

If using Analog control, change "Relays" to "Analogout". Choose the first Analogout position as #1 if feeding base. Choose the second Analogout position as #2 if feeding acid. Select the analog output current range required by each control device, 4-20 or 0-20 mA. Press [ENTER].

10.4 Tune parameters

(Path MENU/PID Setup/Tune Parameters)

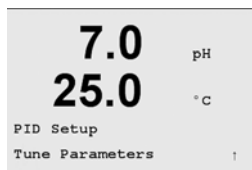

This menu assigns control to a measurement and sets the setpoint, tuning parameters and non-linear functions of the controller through a series of screens.

10.4.1 PID assignment & tuning

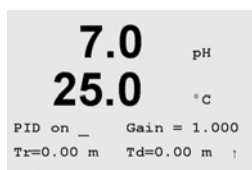

Assign the measurement, a, b, c, or d to be controlled after "PID on_". Set the Gain (unitless), Integral or Reset time Tr (minutes) and Rate or Derivative time Td (minutes) needed for control. Press [ENTER]. Gain, Reset and Rate are later adjusted by trial and error based on process response.

10.4.2 Setpoint & deadband

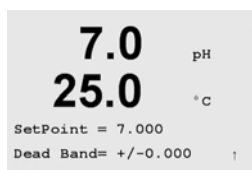

Enter the desired setpoint value and the deadband around the setpoint, where no proportional control action will take place. Press [ENTER].

10.4.3 Proportional limits

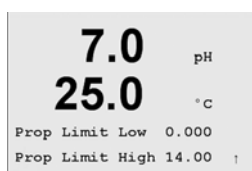

Enter the low and high proportional limits—the range over which control action is required. Press [ENTER].

10.4.4 Corner points



Enter the low and high corner points in pH units and the respective output values from -1 to +1, shown in the figure as -100 to +100%. Press [ENTER].

 **NOTE:** Corner points will be automatically adjusted to provide linear control if they are incorrectly set to produce higher gain than linear control.

10.5 PID display setup

(Path MENU/PID Setup/PID Display)



This display enables display of PID control status including % output, reagent and Auto/Manual, in the normal measurement mode. (In addition, for the display to be enabled, a measurement must be assigned under Tune Parameters and a relay or analog output must be assigned under Mode.)





If Yes is selected the status (Man or Auto) and control output (% acid or % base) will be displayed on the bottom line.

11 Service

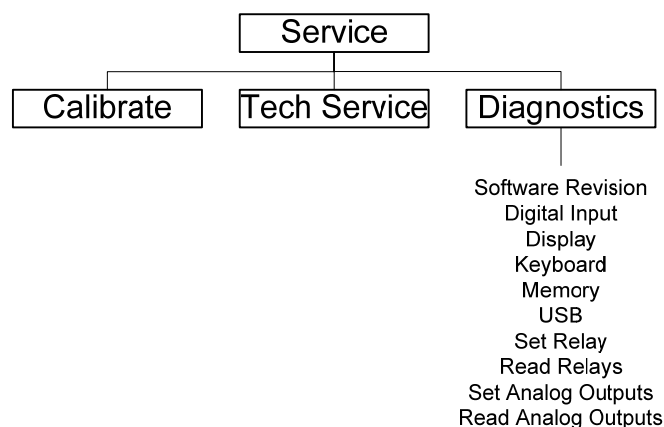
(PATH: Menu/Service)



While in Measurement mode press the  key. Press the  or  key to navigate to the Service – Menu. After selecting the Service – Menu enter the Service security code and then press the [ENTER] key to confirm the code.

11.1 Diagnostics

(PATH: Menu/Service/Diagnostics)

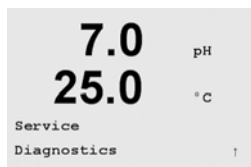

This Menu is a valuable tool for troubleshooting and provides diagnostic functionality for following items: SW Revision, Digital Inputs, Display, Keypad, Memory, Set Relay, Read Relays, Set Analog Outputs, Read Analog Outputs

11.1.1 Model/software revision

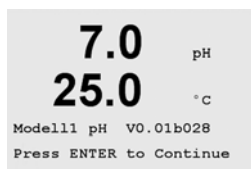

Essential information for every Service call is the model and software revision number. This Menu shows the transmitter part number, serial number and software version number. Press [ENTER] to exit from this display.

11.1.2 Digital input

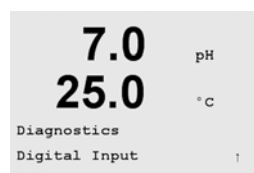

The digital Input menu shows the state of the digital input. Press [ENTER] to exit from this display.

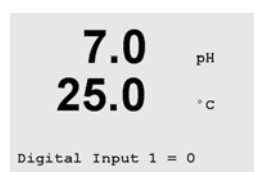

11.1.3 Display

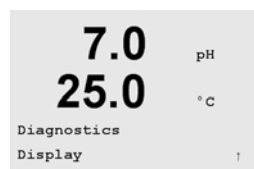

All pixels of the display will be lit for 15 seconds to allow troubleshooting of the display. After 15 seconds the transmitter will return to the normal measuring mode or press [ENTER] to exit sooner.

11.1.4 Keypad

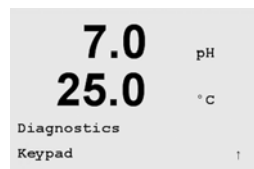

For the keypad diagnostics the display will indicate which key is pressed. Pressing [ENTER] will return the transmitter to the normal measuring mode.

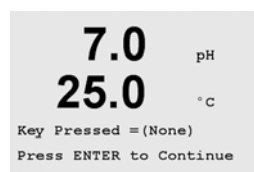

11.1.5 Memory



If Memory is selected then the transmitter will perform a RAM and ROM memory test. Test patterns will be written to and read from all RAM memory locations. The ROM checksum will be recalculated and compared to the value stored in the ROM.

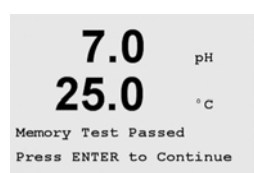

11.1.6 Set relay



The Set Relays diagnostic menu allows for the manual activation/deactivation of each Relay.

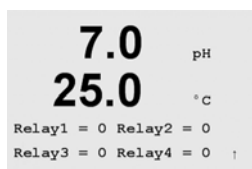

11.1.7 Read relays

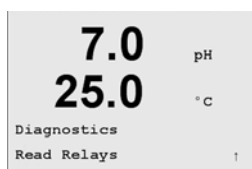

The Read Relays diagnostic menu shows the state of each Relay. Press [ENTER] to exit from this display.

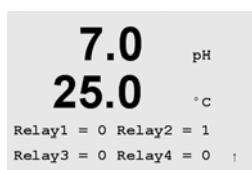

11.1.8 Set analog outputs

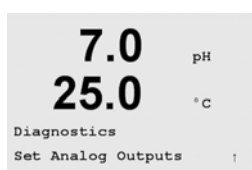

This menu enables the user to set all analog outputs to any mA value within the 0-22 mA range.

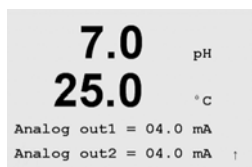

11.1.9 Read analog outputs

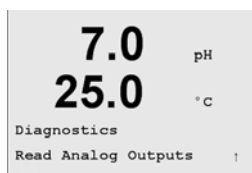

This menu shows the mA value of the analog Outputs. Press [ENTER] to exit from this display.

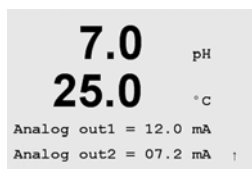

11.2 Calibrate

(PATH: Menu/Service/Calibrate)



This menu has the options to calibrate the transmitter and the analog outputs and also allows the unlocking of calibration functionality.

11.2.1 Calibrate meter

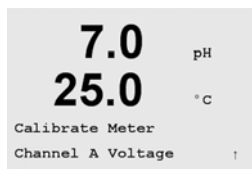

Channel A calibration can be selected as Voltage, Temperature, Rg Diagnostic and Rr Diagnostic.

11.2.1.1 Voltage

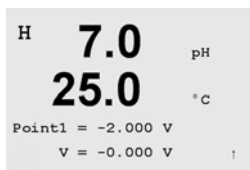

Enter the value for Point 1 of the calibration.

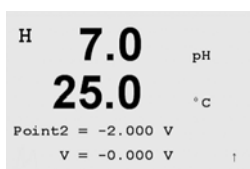

Enter the value for Point 2 of the calibration.

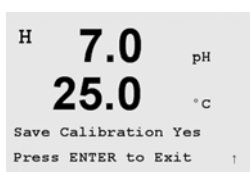

Pressing the [ENTER] key after entering Point 2 will bring up a confirmation screen. Selecting No will discard the entered values, selecting Yes will make the entered values the current ones.

11.2.1.2 Temperature

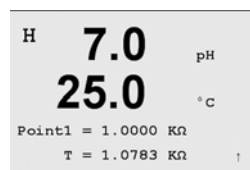

Enter the value for Point 1 of the calibration, according to the attached Resistor.

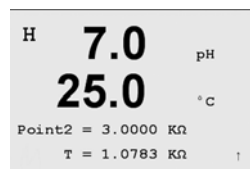

Enter the value for Point 2 of the calibration, according to the attached Resistor.

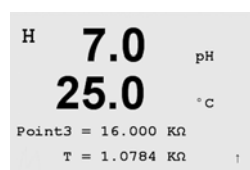

Enter the value for Point 3 of the calibration, according to the attached Resistor.

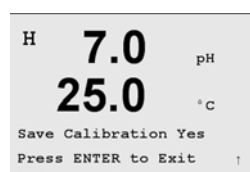

Pressing the [ENTER] key after entering Point 3 will bring up a confirmation screen. Selecting No will discard the entered values, selecting Yes will make the entered values the current ones.

11.2.1.3 Rg diagnostic

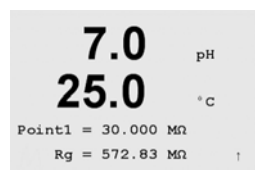

Enter the value for Point 1 of the calibration according to the resistor connected across the pH glass electrode measuring input.

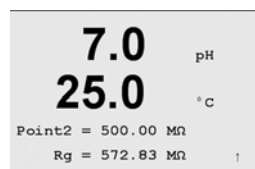

Enter the value for Point 2 of the calibration according to the resistor connected across the pH glass electrode measuring input.

Pressing the [ENTER] key after entering Point 2 will bring up a confirmation screen. Selecting No will discard the entered values, selecting Yes will make the entered values the current ones.

11.2.1.4 Rr diagnostic

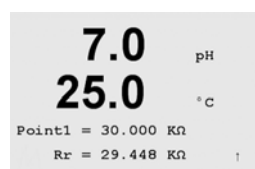

Enter the value for Point 1 of the calibration according to the resistor connected across the pH reference measuring input.

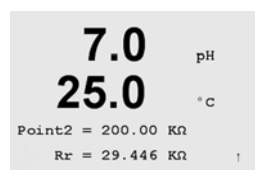

Enter the value for Point 2 of the calibration according to the resistor connected across the pH reference measuring input.

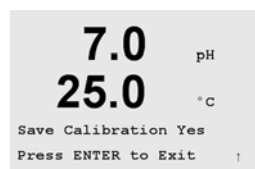

Pressing the [ENTER] key after entering Point 2 will bring up a confirmation screen. Selecting No will discard the entered values, selecting Yes will make the entered values the current ones.

11.2.2 Calibrate analog

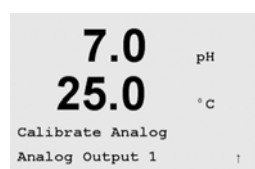

Select the Analog Output you wish to calibrate. Each Analog output can be calibrated at 4 and 20 mA.

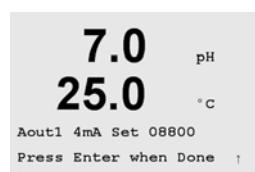

Connect a Meter to the Analog output terminals and then adjust the five digit number in the display to set the output to 4mA and repeat for 20 mA.



As the five digit number is increased the output current increases and as the number is decreased the output current decreases. Thus coarse changes in the output current can be made by changing the thousands or hundreds digits and fine changes can be made by changing the tens or ones digits.

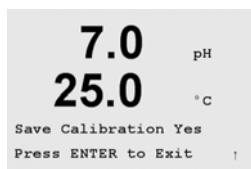

Pressing the [ENTER] key after entering both values will bring up a confirmation screen. Selecting No will discard the entered values, selecting Yes will make the entered values the current ones.

11.2.3 Calibrate unlock



Select this Menu to configure the CAL Menu, see chapter 7.

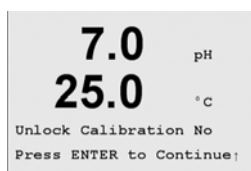

Selecting Yes means that Meter and Analog Output calibration Menus will be selectable under the CAL Menu. Selecting No means that only the Sensor calibration is available under the CAL Menu.

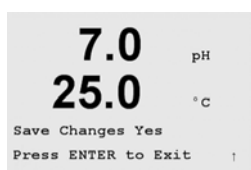

Pressing the [ENTER] key after the selection will bring up a confirmation screen.

11.3 Tech Service

(PATH: Menu/Service/ Tech Service)



NOTE: This menu is for Mettler-Toledo Service personnel use only.

12 Info

(PATH: Info)

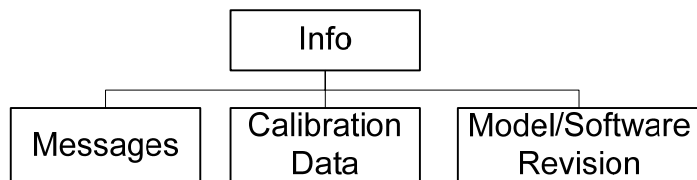

Pressing the  key will display the Info Menu with the options Messages and Calibration Data

12.1 Messages

(PATH: Info/Messages)



The most recent message is displayed. The up and down arrow keys allow scrolling through the last four messages that have occurred.



Clear Messages clears all the messages. Messages are added to the message list when the condition that generates the message first occurs. If all messages are cleared and a message condition still exists and started before the clear then it will not appear in the list. For this message to re-occur in the list the condition must go away and then reappear.

12.2 Calibration data

(PATH: Info/Calibration Data)



Selecting Calibration Data displays the slope (S) and offset calibration constants (Z).

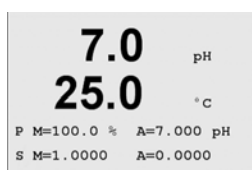

P = calibration constants for the primary measurement
 S = calibration constants for the secondary measurement

12.3 Model/software revision

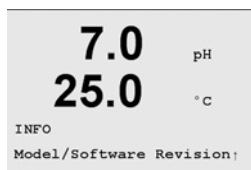

Selecting Model/Software Revision will display the installed Firmware revision.

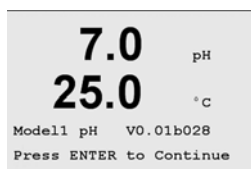

The displayed information is important for any Service call. Press Enter to return to the normal measurement mode.

13 Maintenance

The device contains no user repairable components. To remove dust, dirt and spots, the external surfaces of the transmitter may be wiped with a damp, lint-free cloth.

13.1 For technical support

For technical support and product information contact your local Mettler-Toledo Sales Office or representative

13.2 Front panel cleaning

Clean the front panel with a damp soft cloth (water only, no solvents). Gently wipe the surface and dry with a soft cloth.

14 Trouble shooting

If the equipment is used in a manner specified by these instructions, the protection provided by the equipment may be impaired.

Review the table below for possible causes of common problems:

Problem	Possible cause
Display is blank.	<ul style="list-style-type: none">- No power to M300- Blown fuse.- LCD display contrast set incorrectly.- Hardware failure.
Incorrect measurement readings.	<ul style="list-style-type: none">- Sensor improperly installed.- Incorrect units selected- Temperature compensation incorrectly set or disabled.- Sensor or transmitter needs calibration.- Sensor or patch cord defective or exceeds recommended maximum length.- Hardware failure.
Measurement readings not stable.	<ul style="list-style-type: none">- Sensors or cables installed too close to equipment that generates high level of electrical noise.- Recommended cable length exceeded.- Averaging set too low.- Sensor or patch cord defective.
Cannot change menu settings.	<ul style="list-style-type: none">- User locked out for security reasons.

14.1 Warning- and alarmlist

Warnings	Description
Warning pH slope > 101%	Slope too big
Warning pH Slope < 95%	Slope too small
Warning pH Zero >7.5 pH	Zero offset too big
Warning pH Zero < 6.5pH	Zero offset too small
Warning pHGs change < 0.3	Glass electrode drift too small
Warning pHGs change > 3	Glass electrode drift too big
Warning pHRef change < 0.3	Reference electrode drift too small
Warning pHRef change > 3	Reference electrode drift too big

Alarms	Description
Watchdog time-out	SW/System fault
Error pH Slope > 102%	Slope too big
Error pH Slope < 90%	Slope too small
Error pH Zero >8.0pH	Zero offset too big
Error pH Zero < 6.0pH	Zero offset too small
Error pH Ref Res >150 K Ω	Reference electrode resistance too big (break)
Error pH Ref Res < 2000 Ω	Reference electrode resistance too small (short)
Error pH Gls Res > 2000M Ω	Glass electrode resistance too big (break)
Error pH Gls Res < 5 M Ω	Glass electrode resistance too small (short)

14.2 Changing the fuse



Make sure that the mains cable is unplugged before changing the fuse. This operation should only be carried out by personnel familiar with the transmitter and who are qualified for such work.

If the power consumption of the M300 transmitter is too high or a manipulation leads to a short circuit the fuse will blow. In this case remove the fuse and replace it with one specified in Chapter 16.

15 Accessories and spare parts

Please contact your local Mettler-Toledo sales office or representative for details on available accessories and spare parts.

16 Specifications

16.1 General specifications

pH range	-1.00 to 15.00 pH
pH Resolution	0.01 pH
pH Relative accuracy	± 0.03 pH
mV range	-1500 to 1500 mV
mV Resolution	01 mV
mV Relative accuracy	± 2 mV
Temperature measuring range	- 30 to + 150.0 °C (-22 to 302 °F)
Temperature resolution	0.1 °C/ °F
Temperature measurement error	± 0.25 °C (± 0.45 °F)
Temperature input	PT 1000 (PT 100 with adapter)
Temperature compensation	auto / manual
Calibration	1 or 2 point calibration, process calibration

16.2 Electrical specifications for 1/2DIN and 1/4DIN versions

Power requirements	100 to 240 V AC or 20 to 30 V DC
Frequency	50 to 60 Hz
Signal output	two (four for 2 channel model) 0/4 to 22 mA outputs for pH/mV and temperature, galvanically isolated
Measurement Error through analog outputs	< 0.5% of full scale
Analog output configuration	Linear, Bi-Linear, Logarithmic, Autoranging
Load	max. 500 Ω
Connection terminals	Detachable screw terminals
Digital communication	USB port, Type B connector
PID process controller	Pulse length, frequency or analog control
Connection terminals	Detachable screw terminals
Digital Input	1 (2 for 2-channel version)
Mains fuse	1.0A slow blow type FC
Relays	2-SPDT mechanical rated at 250VAC, 3Amps 2-SPST mechanical rated at 250VAC, 3Amps (2- channel version only) 2-Reed rated at 250VAC or DC, 0.5Amp switching
Alarm Relay delay	0 – 999 s
Keypad	5 tactile feedback keys
Display	four-line

16.3 Mechanical specifications for 1/4DIN version

Dimensions (housing - H x W x D)*	90 x 90 x 140 mm (1/4DIN model)
Front bezel – (H x W)	102 x 102 mm
Max. depth	125 mm (excludes plug-in connectors)
Weight	0.6kg
Material	ABS/polycarbonate
Insulation/rating	IP 65 (front) / IP 20 (housing)

* H=Height, W=Width, D=Depth

16.4 Mechanical specifications for 1/2DIN version

Dimensions (housing - L x H x W)*	144 x 144 x 116 mm
Front bezel - H x W	150 x 150 mm
Max. D - panel mounted	87 mm (excludes plug-in connectors)
Weight	0.95kg
Material	ABS/polycarbonate
Insulation / rating	NEMA 4X, IP 65

* H=Height, W=Width, D=Depth

16.5 Environmental specifications for 1/2DIN and 1/4DIN versions

Storage temperature	-40 to 70 °C (-40 to 158 °F)
Ambient temperature operating range	-10 to 50 °C (14 to 122 °F)
Relative humidity	0 to 95% non-condensing
Emissions	According to EN55011 Class A
UL Electrical Environment	Installation (overvoltage) category II

17 Default tables

Alarm (except flow)	Relay	2	
	diagnostics	off	
	SW	off	
	HW	off	
	delay	1	sec
	hysteresis	0	
	state	inverted	
Clean	relay	1	
	hold mode	NA	
	interval	0	Hrs
	clean time	0	Sec
	state	normal	
	delay	0	
	hysteresis	0	
Language		English	
Passwords	administrator	00000	
	operator	00000	
All Relays (unless otherwise specified)	delay	10	sec
	hysteresis	5	%
	state	normal	
	hold mode	NA	
Lockout	(on/off)	no = off	
Channel A	measurement a	pH	pH
	measurement b	temperature	°C
	measurement c		
	measurement d		
Cal constants	pH	M=1.0, A=0.0	
	temperature	M=1.0, A=0.0	
pH Buffer		Mettler-9	
Analog Out	1	Ch A - pH	
	2	Ch A - temperature	
All analog out	mode	4 - 20 mA	
	type	normal	
	alarm	off	
	hold mode	last	
pH	value 4 mA	2	pH
	value 20 mA	12	pH
Temperature	value 4 mA	0	°C
	value 20 mA	100	°C
Set point 1	signal	a	
	type	off	
	value	12	pH
Relay 3	set point	1	
Set point 2	signal	c	
	type	Off	
	value	0	°C
Relay 4	set point	2	
Resolution	Temperature	0.1	°C
	pH	0.1	pH

18 Warranty

METTLER TOLEDO warrants this product to be free from significant deviations in material and workmanship for a period of one year from the date of purchase. If repair is necessary and not the result of abuse or misuse within the warranty period, please return by freight pre-paid and amendment will be made without any charge. METTLER TOLEDO's Customer Service Dept. will determine if the product problem is due to deviations or customer abuse. Out-of-warranty products will be repaired on an exchange basis at cost.

The above warranty is the only warranty made by METTLER TOLEDO and is lieu of all other warranties, expressed or implied, including, without limitation, implied warranties of merchantability and fitness for a particular purpose. METTLER TOLEDO shall not be liable for any loss, claim, expense or damage caused by, contributed to or arising out of the acts or omissions of the Buyer or Third Parties, whether negligent or otherwise. In no event shall METTLER TOLEDO's liability for any cause of action whatsoever exceed the cost of the item giving rise to the claim, whether based in contract, warranty, indemnity, or tort (including negligence).

19 UL Statement (pending)

Mettler-Toledo Thornton, Inc., 36 Middlesex Turnpike, Bedford, MA 01730, USA has obtained Underwriters Laboratories' listing for 300 Model Transmitters. They bear the cULus Listed mark, signifying that the products have been evaluated to the applicable ANSI/UL and CSA Standards for use in the U.S. and Canada

20 Buffer tables

M300 transmitters have the ability to do automatic pH buffer recognition. The following tables show different standard buffers that are automatically recognized.

20.1 Mettler-9

Temp (°C)	pH of buffer solutions			
0	2.03	4.01	7.12	9.52
5	2.02	4.01	7.09	9.45
10	2.01	4.00	7.06	9.38
15	2.00	4.00	7.04	9.32
20	2.00	4.00	7.02	9.26
25	2.00	4.01	7.00	9.21
30	1.99	4.01	6.99	9.16
35	1.99	4.02	6.98	9.11
40	1.98	4.03	6.97	9.06
45	1.98	4.04	6.97	9.03
50	1.98	4.06	6.97	8.99
55	1.98	4.08	6.98	8.96
60	1.98	4.10	6.98	8.93
65	1.99	4.13	6.99	8.90
70	1.99	4.16	7.00	8.88
75	2.00	4.19	7.02	8.85
80	2.00	4.22	7.04	8.83
85	2.00	4.26	7.06	8.81
90	2.00	4.30	7.09	8.79
95	2.00	4.35	7.12	8.77

20.2 Mettler-10

Temp (°C)	pH of buffer solutions			
0	2.03	4.01	7.12	10.32
5	2.02	4.01	7.09	10.25
10	2.01	4.00	7.06	10.18
15	2.00	4.00	7.04	10.12
20	2.00	4.00	7.02	10.06
25	2.00	4.01	7.00	10.01
30	1.99	4.01	6.99	9.97
35	1.99	4.02	6.98	9.93
40	1.98	4.03	6.97	9.89
45	1.98	4.04	6.97	9.86
50	1.98	4.06	6.97	9.83
55	1.98	4.08	6.98	9.83
60	1.98	4.10	6.98	9.83
65	1.99	4.13	6.99	9.83
70	1.99	4.16	7.00	9.83
75	2.00	4.19	7.02	9.83
80	2.00	4.22	7.04	9.83
85	2.00	4.26	7.06	9.83
90	2.00	4.30	7.09	9.83
95	2.00	4.35	7.12	9.83

20.3 NIST Technical Buffers

Temp (°C)	pH of buffer solutions				
0	1.67	4.00	7.115	10.32	13.42
5	1.67	4.00	7.085	10.25	13.21
10	1.67	4.00	7.06	10.18	13.01
15	1.67	4.00	7.04	10.12	12.80
20	1.675	4.00	7.015	10.06	12.64
25	1.68	4.005	7.00	10.01	12.46
30	1.68	4.015	6.985	9.97	12.30
35	1.69	4.025	6.98	9.93	12.13
40	1.69	4.03	6.975	9.89	11.99
45	1.70	4.045	6.975	9.86	11.84
50	1.705	4.06	6.97	9.83	11.71
55	1.715	4.075	6.97	9.83*	11.57
60	1.72	4.085	6.97	9.83*	11.45
65	1.73	4.10	6.98	9.83*	11.45*
70	1.74	4.13	6.99	9.83*	11.45*
75	1.75	4.14	7.01	9.83*	11.45*
80	1.765	4.16	7.03	9.83*	11.45*
85	1.78	4.18	7.05	9.83*	11.45*
90	1.79	4.21	7.08	9.83*	11.45*
95	1.805	4.23	7.11	9.83*	11.45*

*Extrapolated

20.4 NIST standard buffers (DIN 19266: 2000-01)

Temp (°C)	pH of buffer solutions			
0				
5	1.668	4.004	6.950	9.392
10	1.670	4.001	6.922	9.331
15	1.672	4.001	6.900	9.277
20	1.676	4.003	6.880	9.228
25	1.680	4.008	6.865	9.184
30	1.685	4.015	6.853	9.144
35	1.694	4.028	6.841	9.095
40	1.697	4.036	6.837	9.076
45	1.704	4.049	6.834	9.046
50	1.712	4.064	6.833	9.018
55	1.715	4.075	6.834	8.985
60	1.723	4.091	6.836	8.962
70	1.743	4.126	6.845	8.921
80	1.766	4.164	6.859	8.885
90	1.792	4.205	6.877	8.850
95	1.806	4.227	6.886	8.833

 **NOTE:** The pH(S) values of the individual charges of the secondary reference materials are documented in a certificate of an accredited laboratory. This certificate is supplied with the respective buffer materials. Only these pH(S) values shall be used as standard values for the secondary reference buffer materials. Correspondingly, this standard does not include a table with standard pH values for practical use. The table above only provides examples of pH(PS) values for orientation.

20.5 Hach buffers

Buffer values up to 60 °C as specified by Bergmann & Beving Process AB.

Temp (°C)	pH of buffer solutions		
0	4.00	7.14	10.30
5	4.00	7.10	10.23
10	4.00	7.04	10.11
15	4.00	7.04	10.11
20	4.00	7.02	10.05
25	4.01	7.00	10.00
30	4.01	6.99	9.96
35	4.02	6.98	9.92
40	4.03	6.98	9.88
45	4.05	6.98	9.85
50	4.06	6.98	9.82
55	4.07	6.98	9.79
60	4.09	6.99	9.76
65	4.09*	6.99*	9.76*
70	4.09*	6.99*	9.76*
75	4.09*	6.99*	9.76*
80	4.09*	6.99*	9.76*
85	4.09*	6.99*	9.76*
90	4.09*	6.99*	9.76*
95	4.09*	6.99*	9.76*

*Values complemented

20.6 Ciba (94) buffers

Temp (°C)	pH of buffer solutions			
0	2.04	4.00	7.10	10.30
5	2.09	4.02	7.08	10.21
10	2.07	4.00	7.05	10.14
15	2.08	4.00	7.02	10.06
20	2.09	4.01	6.98	9.99
25	2.08	4.02	6.98	9.95
30	2.06	4.00	6.96	9.89
35	2.06	4.01	6.95	9.85
40	2.07	4.02	6.94	9.81
45	2.06	4.03	6.93	9.77
50	2.06	4.04	6.93	9.73
55	2.05	4.05	6.91	9.68
60	2.08	4.10	6.93	9.66
65	2.07*	4.10*	6.92*	9.61*
70	2.07	4.11	6.92	9.57
75	2.04*	4.13*	6.92*	9.54*
80	2.02	4.15	6.93	9.52
85	2.03*	4.17*	6.95*	9.47*
90	2.04	4.20	6.97	9.43
95	2.05*	4.22*	6.99*	9.38*

*Extrapolated

20.7 Merck Titrisols, Reidel Fixanals

Temp (°C)	pH of buffer solutions				
0	2.01	4.05	7.13	9.24	12.58
5	2.01	4.05	7.07	9.16	12.41
10	2.01	4.02	7.05	9.11	12.26
15	2.00	4.01	7.02	9.05	12.10
20	2.00	4.00	7.00	9.00	12.00
25	2.00	4.01	6.98	8.95	11.88
30	2.00	4.01	6.98	8.91	11.72
35	2.00	4.01	6.96	8.88	11.67
40	2.00	4.01	6.95	8.85	11.54
45	2.00	4.01	6.95	8.82	11.44
50	2.00	4.00	6.95	8.79	11.33
55	2.00	4.00	6.95	8.76	11.19
60	2.00	4.00	6.96	8.73	11.04
65	2.00	4.00	6.96	8.72	10.97
70	2.01	4.00	6.96	8.70	10.90
75	2.01	4.00	6.96	8.68	10.80
80	2.01	4.00	6.97	8.66	10.70
85	2.01	4.00	6.98	8.65	10.59
90	2.01	4.00	7.00	8.64	10.48
95	2.01	4.00	7.02	8.64	10.37

20.8 WTW buffers

Temp (°C)	pH of buffer solutions			
0	2.03	4.01	7.12	10.65
5	2.02	4.01	7.09	10.52
10	2.01	4.00	7.06	10.39
15	2.00	4.00	7.04	10.26
20	2.00	4.00	7.02	10.13
25	2.00	4.01	7.00	10.00
30	1.99	4.01	6.99	9.87
35	1.99	4.02	6.98	9.74
40	1.98	4.03	6.97	9.61
45	1.98	4.04	6.97	9.48
50	1.98	4.06	6.97	9.35
55	1.98	4.08	6.98	
60	1.98	4.10	6.98	
65	1.99	4.13	6.99	
70	2.00	4.16	7.00	
75	2.00	4.19	7.02	
80	2.00	4.22	7.04	
85	2.00	4.26	7.06	
90	2.00	4.30	7.09	
95	2.00	4.35	7.12	

METTLER TOLEDO Market Organizations

Sales and Service:

Australia

Mettler-Toledo Ltd.
220 Turner Street
Port Melbourne
AUS - 3207 Melbourne / VIC
Phone +61 31300 659 761
Fax +61 3 9645 3935
e-mail mtausprocess@mt.com

Austria

Mettler-Toledo Ges.m.b.H.
Südrandstraße 17
A - 1230 Wien
Phone +43 1 604 19 80
Fax +43 1 604 28 80
e-mail infoprocess.mtat@mt.com

Brazil

Mettler-Toledo Ind. e Com. Ltda.
Alameda Araguaia
451 - Alphaville
BR - 06455-000 Barueri / SP
Phone +55 11 4166 74 00
Fax +55 11 4166 74 01
e-mail sales@mettler.com.br
service@mettler.com.br

China

Mettler-Toledo Instruments
(Shanghai) Co. Ltd.
589 Gui Ping Road
Cao He Jing
CN - 200233 Shanghai
Phone +86 21 64 85 04 35
Fax +86 21 64 85 33 51
e-mail mtcs@public.sta.net.cn

Croatia

Mettler-Toledo d.o.o.
Mandlova 3
HR - 10000 Zagreb
Phone +385 1 292 06 33
Fax +385 1 295 81 40
e-mail mt.zagreb@mt.com

Czech Republic

Mettler-Toledo spol.s.r.o.
Trebohosticka 2283 / 2
CZ - 100 00 Praha 10
Phone +420 2 72 123 150
Fax +420 2 72 123 170
e-mail sales.mtcz@mt.com

Denmark

Mettler-Toledo A/S
Naverland 8
DK - 2600 Glostrup
Phone +45 43 27 08 00
Fax +45 43 27 08 28
e-mail info.mtdk@mt.com

France

Mettler-Toledo
Analyse Industrielle Sarl
30, Boulevard de Douaumont
BP 949
F - 75829 Paris Cedex 17
Phone +33 1 47 37 06 00
Fax +33 1 47 37 46 26
e-mail mtpro-f@mt.com

Germany

Mettler-Toledo GmbH
ProzeBanalytik
Ockerweg 3
D - 35396 Gießen
Phone +49 641 507 333
Fax +49 641 507 397
e-mail prozess@mt.com

Great Britain

Mettler-Toledo LTD
64 Boston Road, Beaumont Leys
GB - Leicester LE4 1AW
Phone +44 116 235 7070
Fax +44 116 236 5500
e-mail enquire.mtuk@mt.com

Hungary

Mettler-Toledo Kereskedelmi KFT
Teve u. 41
HU - 1139 Budapest
Phone +36 1 288 40 40
Fax +36 1 288 40 50
e-mail mthu@axelero.hu

India

Mettler-Toledo India Private Limited
Amar Hill, Saki Vihar Road
Powai
IN - 400 072 Mumbai
Phone +91 22 2857 0808
Fax +91 22 2857 5071
e-mail sales.mtin@mt.com

Italy

Mettler-Toledo S.p.A.
Via Vialba 42
I - 20026 Novate Milanese
Phone +39 02 333 321
Fax +39 02 356 2973
e-mail customercare.italia@mt.com

Japan

Mettler-Toledo K.K.
Process Division
5F Tokyo Ryutsu Center, Annex B
6-1-1 Heiwajima, Ohta-ku
JP - 143-0006 Tokyo
Phone +81 3 5762 07 06
Fax +81 3 5762 09 71
e-mail helpdesk.ing.jp@mt.com

Malaysia

Mettler-Toledo (M) Sdn Bhd
Bangunan Electroscon Holding
Lot 8 Jalan Astaka U8 / 84
Seksyen U8, Bukit Jelutong
MY - 40150 Shah Alam Selangor
Phone +60 3 78 45 57 73
Fax +60 3 78 45 87 73
e-mail
MT-MY.CustomerSupport@mt.com

Mexico

Mettler-Toledo S.A. de C.V.
Pino No. 350, Col. Sta.
MA. Insurgentes, Col Atlampa
MX - 06430 México D.F.
Phone +52 55 55 47 57 00
Fax +52 55 55 41 22 28
e-mail mt.mexico@mt.com

Poland

Mettler-Toledo (Poland) Sp.z.o.o.
ul. Poleczki 21
PL - 02-822 Warszawa
Phone +48 22 545 06 80
Fax +48 22 545 06 88
e-mail polska@mt.com

Russia

Mettler-Toledo Vostok ZAO
Sretenskij Bulvar 6/1
Office 6
RU - 101000 Moscow
Phone +7 495 621 92 11
Fax +7 495 621 63 53
+7 495 621 78 68
e-mail inforus@mt.com

Singapore

Mettler-Toledo (S) Pte. Ltd.
Block 28
Ayer Rajah Crescent # 05-01
SG - 139959 Singapore
Phone +65 6890 00 11
Fax +65 6890 00 12
+65 6890 00 13
e-mail precision@mt.com

Slovakia

Mettler-Toledo s.r.o.
Bulharska 61
SK - 82104 Bratislava
Phone +421 244 44 12 20
Fax +421 244 44 12 23
e-mail predaj@mt.com

Slovenia

Mettler-Toledo d.o.o.
Peske 12
SI - 1236 Trzin
Phone +386 1 530 80 50
Fax +386 1 562 17 89
e-mail keith.racman@mt.com

South Korea

Mettler-Toledo (Korea) Ltd.
Yeil Building 1 & 2 F
124-5, YangJe-Dong
SeCho-Ku
KR - 137-130 Seoul
Phone +82 2 3498 3500
Fax +82 2 3498 3555
e-mail Sales_MTKR@mt.com

Spain

Mettler-Toledo S.A.E.
C / Miguel Hernández, 69-71
ES - 08908 L'Hospitalet de Llobregat
(Barcelona)
Phone +34 93 223 76 00
Fax +34 93 223 76 01
e-mail bcn.centralita@mt.com

Sweden

Mettler-Toledo AB
Virkesvägen 10
Box 92161
SE - 12008 Stockholm
Phone +46 8 702 50 00
Fax +46 8 642 45 62
e-mail sales.mts@mt.com

Switzerland

Mettler-Toledo (Schweiz) GmbH
Im Langacher
Postfach
CH - 8606 Greifensee
Phone +41 44 944 45 45
Fax +41 44 944 45 10
e-mail salesola.ch@mt.com

Thailand

Mettler-Toledo (Thailand) Ltd.
272 Soi Soonvijai 4
Rama 9 Rd., Bangkok
Huay Kwang
TH - 10320 Bangkok
Phone +66 2 723 03 00
Fax +66 2 719 64 79
e-mail MT-TH.Process@mt.com

USA / Canada

Mettler-Toledo Ingold, Inc.
36 Middlesex Turnpike
Bedford, MA 01730, USA
Phone +1 781 301 8800
Toll free +1 800 352 8763
Fax +1 781 271 0681
e-mail mtprouds@mt.com
ingold@mt.com



Management System
certified according to
ISO 9001 / ISO 14001

Subject to technical changes.
© Mettler-Toledo AG, Process Analytics
02 / 07 - Printed in Switzerland. 52 121 304

Mettler-Toledo AG, Process Analytics
Industrie Nord, CH - 8902 Urdorf, Switzerland
Tel. + 41 44 729 62 11, Fax +41 44 729 66 36

www.mt.com/pro