

Operating instructions Bedienungsanleitung Mode d'emploi

METTLER TOLEDO

LJ16/LP16

Temperature calibration set

Temperaturkalibrier-Set

214240

Jeu de calibrage de température







This temperature reference disk allows the user to perform a check on the temperature of the LJ16/LP16 in a simple manner and to adjust the apparatus if need be. This is especially important for users who work according to the guidelines of GLP, GMP, ISO 9001, etc.

Order number for measuring gauge:
214247

Diese Temperatur-Referenzscheibe erlaubt dem Benutzer, auf einfache Weise eine Kontrolle der Temperatur am LJ16/LP16 durchzuführen und das Instrument gegebenenfalls zu justieren. Dies ist von besonderer Bedeutung für Anwender, welche nach den Richtlinien von GLP, GMP, ISO 9001 usw. arbeiten.

Bestellnummer für Messstreifen:
214247

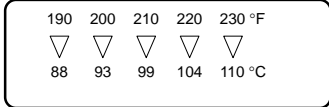
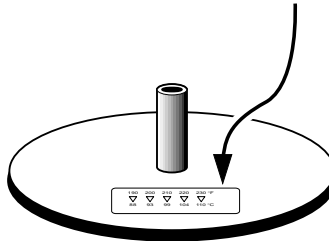
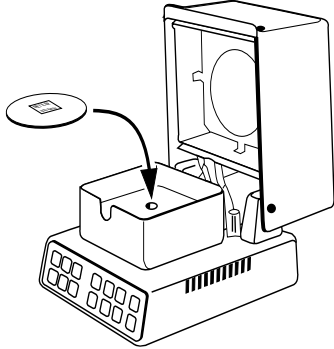
Cette disque de référence de température permet à l'utilisateur, de manière simple, d'effectuer un contrôle de température sur le LJ16/LP16 et d'ajuster l'instrument le cas échéant. Il s'agit d'un point important pour les utilisateurs qui doivent travailler selon les directives GLP, GMP, ISO 9001 et autres. Numéro de commande pour la jauge de mesure: 214247

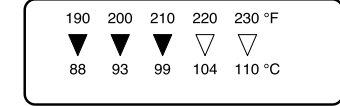
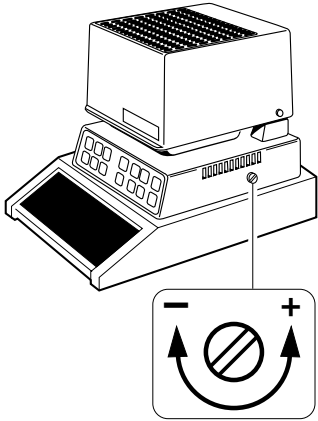
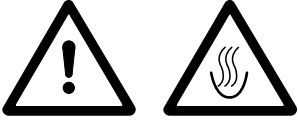
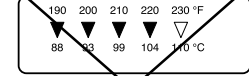
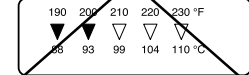
<p>1</p>  Temp.: 100°C  Time: 20 min  	<p>2</p>  	<p>3</p> 
<p>4</p>  20 min Wait Warten Attender	<p>6</p>  O.K.	<p>7</p> 
<p>5</p> 	<p>   </p> 