

# Operating instructions and installation information

## METTLER TOLEDO MultiRange ID7-Count<sup>2000</sup> application software

**METTLER TOLEDO**

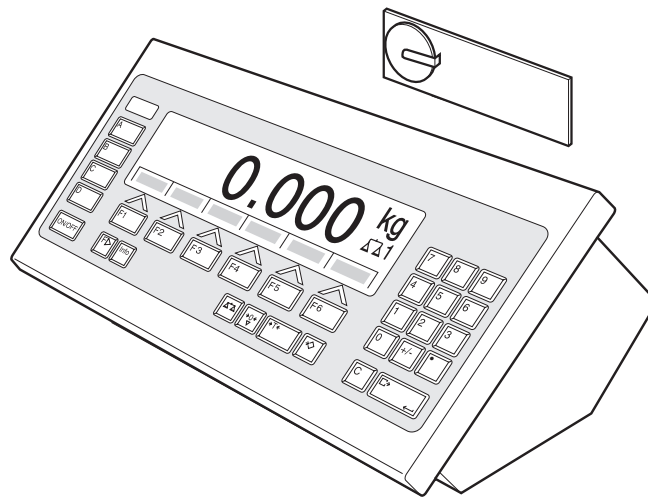



# Contents

	Page
<b>1</b>	<b>Introduction and assembly ..... 2</b>
1.1	Introduction ..... 2
1.2	Safety precautions ..... 2
1.3	Installing ID7-Count ..... 2
<b>2</b>	<b>Counting functions ..... 5</b>
2.1	COUNTING application ..... 5
2.2	PIECE-FILLING application ..... 9
2.3	NEUTRAL MEASUREMENT application ..... 16
2.4	Monitoring reference weight ..... 19
2.5	Automatic reference optimization ..... 19
2.6	Statistical evaluation of reference pieces ..... 20
2.7	Counting with the DeltaTrac ..... 21
2.8	Working with several weighing platforms ..... 22
2.9	PE balance as reference balance ..... 23
2.10	Recall application-specific information ..... 23
<b>3</b>	<b>Settings in the master mode ..... 24</b>
3.1	PAC master mode block ..... 24
<b>4</b>	<b>Application blocks ..... 34</b>
4.1	PAC application blocks ..... 34
<b>5</b>	<b>What to do if ...? ..... 40</b>
<b>6</b>	<b>Technical data ..... 41</b>
<b>7</b>	<b>Appendix ..... 42</b>
7.1	Connection diagram and terminal assignment for 8-ID7 relay box ..... 42
7.2	Connection suggestions for various vibration conveyors ..... 43
<b>8</b>	<b>Index ..... 44</b>

# 1 Introduction and assembly

## 1.1 Introduction

ID7-Count is an application software for the METTLER TOLEDO ID7-... weighing terminal. The functions of the ID7-Count can be used after replacing the memory module.

### Documentation

The ID7-... weighing terminal is provided with operating instructions and installation information for the original configuration of the weighing terminal. Please see these operating instructions and installation information for basic information on working with the ID7-... weighing terminal.

These operating instructions and installation information contain additional information on installing and using the ID7-Count application software.

## 1.2 Safety precautions

### 1.2.1 Installation in explosion protected ID7xx-... weighing terminal



#### EXPLOSION HAZARD

The ID7xx-... weighing terminal may only be opened by METTLER TOLEDO service technicians.

→ To install the ID7-Count application software, please contact METTLER TOLEDO Service.

### 1.2.2 Installing in ID7-... weighing terminal



▲ Only authorized personnel may open the weighing terminal and install the ID7-Count application software.

▲ Before opening the terminal, pull the power plug or switch off the power supply for terminals with a fixed connection.

## 1.3 Installing ID7-Count

### 1.3.1 Opening ID7-... weighing terminal

#### Desk unit

1. Unscrew the screws on the underside of the cover.
2. Lay down the cover toward the front. In doing so, make sure that the cables are not damaged.

**Wall unit**

1. Unscrew the screws on the underside of the cover and fold the cover toward the front. When doing so, make sure that the cables are not damaged.
2. Fold open the mounting plate.

**Panel unit**

1. Unscrew the 10 hex bolts on cut-out on the inside of the switch cabinet.
2. Remove the cover from the switch cabinet and fold toward the front. When doing so, make sure that the cables are not damaged.
3. Fold open the mounting plate.

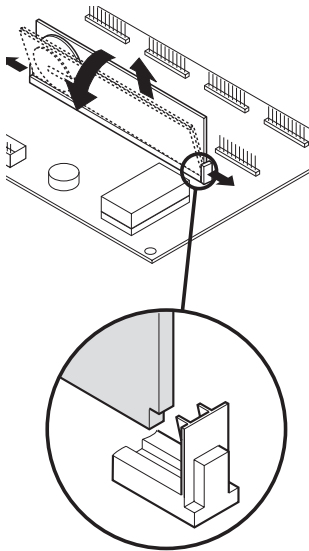
**1.3.2 Mounting ID7-Count**

1. Bend the bracket of the memory module outward on both sides, tilt the memory module forward and remove.
2. Insert the ID7-Count memory module tilted slightly toward the front and move it into the vertical position until it engages. The empty space of the module must be on the bottom right.

**1.3.3 Closing ID7-... weighing terminal****Closing desk unit**

1. Lay device on cover and fix slightly in place with 3 screws.
2. Press unit into cover so that 3 engaging springs engage.
3. Tighten screws.

**CAUTION**

The IP68 protection type can only be guaranteed when the weighing terminal is closed again properly.

- The 3 engaging springs must be completely engaged.
- Make sure that the keypad cable is not pinched.

**Closing wall unit**

1. Fold in the mounting plate.
2. Position the cover and screw on again. When doing so, make sure that no cables are pinched.

**Closing panel unit**

1. Fold in the mounting plate and position the cover on the cut-out again.
2. Secure the cover on the switch cabinet from the inside with 10 screws. When doing so, make sure that no cables are pinched.

## 2 Counting functions

The ID7-Count is equipped with three different counting applications which can be set in the master mode: COUNTING, PIECE-FILLING and NEUTRAL MEASUREMENT. For all applications a reference value is entered prior to counting.

### 2.1 COUNTING application

After a reference value (pieces or piece weight) is specified, the ID7-Count determines the related number of pieces for the COUNTING application from the measured weight value.

#### Prerequisite

The COUNTING application is selected in the master mode.

**Function keys** The function keys for the COUNTING application are assigned as follows:

REF 10	REF N	REF W	PLUS	SUM	← →
Copy standard reference quantity. Factory setting: 10 pieces	Enter variable reference quantity	Enter reference piece weight	Totalize pieces	Display and print total pieces	Switch back and forth between total pieces and pieces of current item

→ Select the function by pressing the function key.

#### Example

→ Press the REF N key.  
Then enter the reference quantity manually with the keypad.

#### When the function keys are otherwise allocated

→ Press the key FUNCTION CHANGE until the function keys' allocation displayed above appears.

### 2.1.1 Specify reference value

#### Standard reference quantity

1. Place reference pieces on or remove from the weighing platform in accordance with the standard reference quantity, e. g. 10 pieces (factory setting).
2. Press REF 10 key.  
The display shows STD REF 10 PCS and then the current quantity in PCS, here 10 PCS.

#### Note

The standard reference quantity can be set in the master mode, see section 3.1.2.

#### Variable reference quantity

1. Place any number of reference pieces on the weighing platform or remove as many reference pieces from it as desired.
2. Press REF N key.  
VAR REF \_ PCS appears in display.
3. Enter the quantity in accordance with the reference pieces placed on the weighing platform or removed from it and confirm with ENTER.  
As long as no stability is reached, REF DETERMINATION appears in display, then number of reference pieces in PCS.

#### Enter reference piece weight numerically

1. Press REF W key.
2. Enter the known piece weight of a reference piece in the displayed unit and confirm with ENTER.

#### Notes

- The weight unit for entering the reference piece weight can be selected with the FUNCTION CHANGE key.
- The entry can be corrected one character at a time with the CLEAR key.

#### Copy reference piece weight constants

1. Enter the number of the reference weight memory: 1 ... 999.
2. Press REF W key.  
Display briefly shows piece designation and piece weight from respective memory and then current number of pieces with unit PCS.

#### Enter article number

If ARTICLE NUMBER ON is selected in the master mode, then the reference weight can be displayed by entering the article number.

If a barcode reader is also connected, then the reference weight can be read in with the barcode reader.

→ Press the CODE A key and enter the article number.

– or –

→ Read in the article number directly with the barcode reader.

Display briefly shows piece designation and piece weight from respective memory and then current number of pieces with unit PCS.



**Notes**

- If no reference values are stored for the article number, the message NEW ARTICLE appears. The reference weight and name of the article can be entered and stored as new constants.
- If REFERENCE WEIGHT UPDATE ON is selected in the master mode, then the reference weight can be changed after displaying the article.

**Monitoring the reference weight**

If the display indicates ADD ... PCS or REF WEIGHT TOO LOW, the minimum reference weight is dropped below, see section 2.4.

→ Lay additional reference pieces on the weighing platform and confirm with ENTER.

**2.1.2 Delete reference value and end counting application**

→ Press REF N or REF W key and delete the reference value with the CLEAR key. The display changes to the normal weight display.

**2.1.3 Additive counting**

During additive counting a container is filled with a certain content.

1. Place an empty container on the weighing platform and tare the weighing platform.
2. Specify a reference value, see section 2.1.1.
3. Lay pieces on the platform.  
The current quantity is displayed in PCS.

**2.1.4 Subtractive counting****Without returning**

Pieces are removed from the filled container until the desired quantity is reached. The removed pieces are not laid back on the weighing platform when doing so.

1. Place a filled container on the weighing platform and tare the weighing platform.
2. Specify a reference value, see section 2.1.1.  
The removed quantity is displayed with a negative sign.
3. Remove pieces.  
The current quantity is displayed in PCS.

**With returning**

Only the reference pieces are removed from the filled container and returned to the weighing platform. Then count all pieces in the container.

1. Place a filled container on the weighing platform and tare the weighing platform.
2. Specify a reference value, see section 2.1.1.  
The removed quantity is displayed with a negative sign.
3. Return the removed reference pieces to the weighing platform.
4. Press TARE SPECIFICATION key, enter the known container weight and confirm with ENTER.  
The quantity and total weight of the container content are displayed.

### 2.1.5 Totalizing

Items of the same piece goods can be totalized as follows:

1. Specify a reference value, see section 2.1.1.
2. Lay 1st item on the weighing platform and press the PLUS key.  
The display shows the quantity of the current item.
3. Relieve weighing platform.
4. Lay additional items on the weighing platform consecutively and repeat steps 1 and 2.  
The display shows the number of totalized items and the total quantity.
5. To switch back and forth between the total quantity of all items and the quantity of the current item, press the ← → key.
6. Press SUM key.  
The total quantity of all items is displayed and printed.
7. To end totalizing, press the SUM, CLEAR key sequence.  
The sum is cleared and the item counter is reset.

#### Notes

- ID7-Count totalizes the gross, net and tare values of the items internally. These sums can be read via the application blocks 315, 316 and 362.
- If CLEARING OF TOTAL ON is set in the master mode, a new reference value cannot be entered until the old sum is cleared. If the sum is not cleared yet, the message CLEARING OF TOTAL appears.

## 2.2 PIECE-FILLING application

After specification of a reference value, the ID7-Count automatically dispenses a specified quantity for the PIECE-FILLING application.

### Prerequisite

The PIECE-FILLING application is selected in the master mode.

**Function keys** The function keys for the PIECE-FILLING application are assigned as follows:

REF 10	REF N	REF W	PLUS	SUM	LIMIT
Copy standard reference quantity. Factory setting: 10 pieces	Enter variable reference quantity	Enter reference piece weight	Totalize pieces	Display and print total pieces	Enter and print filling parameters

→ Select the function by pressing the function key.

### Example

→ Press the REF N key.  
Then enter the reference quantity manually with the keypad.

### When the function keys are otherwise allocated

→ Press the key FUNCTION CHANGE until the function keys' allocation displayed above appears.



### CAUTION

Danger of injury when pressing keys which start and stop the filling system or control the valves!

→ Before pressing these keys, make sure that no one is in the area of moving system parts.

### 2.2.1 Filling system

With feed valves or feed chutes controlled with coarse and fine feed, the filling sample is automatically infed up to the specified target quantity.

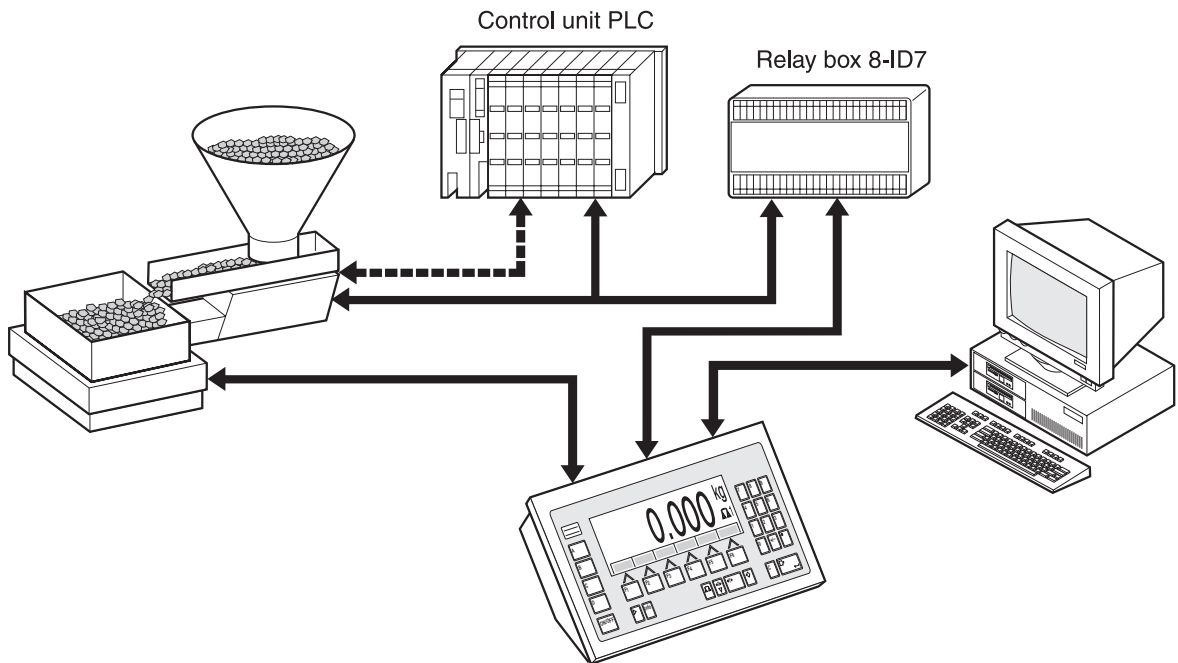

The control signals for the feed valves are transmitted to the 8-ID7 relay box via the RS485-ID7 interface. The 8-ID7 relay box controls the filling system either directly or via an additional external control unit (PLC). In the case of overloading or underloading of the weighing platform, all valves are closed immediately.

### 2.2.2 Filling process

Filling is carried out in 5 consecutive steps:

- **Automatic tare** – Automatic taring of the container and start of filling
- **Coarse feed** – Filling with coarse feed up to the coarse/fine feed switchover point (Limit 1)
- **Fine feed** – Filling with fine feed up to switch-off point the fine feed (Limit 2)
- **Refill correction** – Refill correction of fine feed beyond Limit 2
- **Refilling** – If the weight value does not lie within the tolerance of the target value at the end of filling, automatic or manual refilling up to the target value

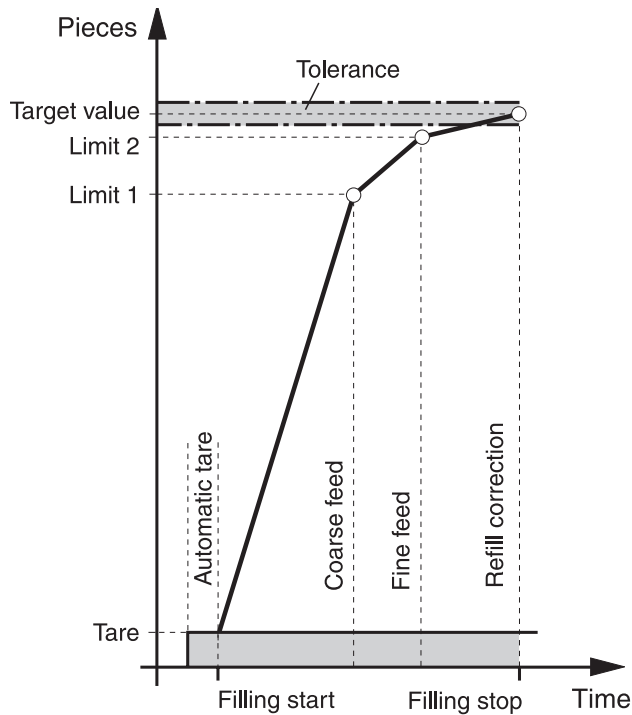

To optimize the filling process, Limit 2 is automatically adjusted with the same component during the next filling process, see REFILL CORRECTION block in section 3.1.3.

If the container is underfilled, automatic or manual refilling can be carried out depending on the settings in the master mode.

**Learn mode**

If no limits are entered or Limit 1 = Limit 2, the ID7-Count determines the two limits automatically in the learn mode:

The coarse feed is opened by up to half the target value (1) and the refill correction (2) determined. Then the fine feed is switched on (3) and the refill correction (4) determined. Following this, filling is carried out up to the target value (5), (6) and (7).

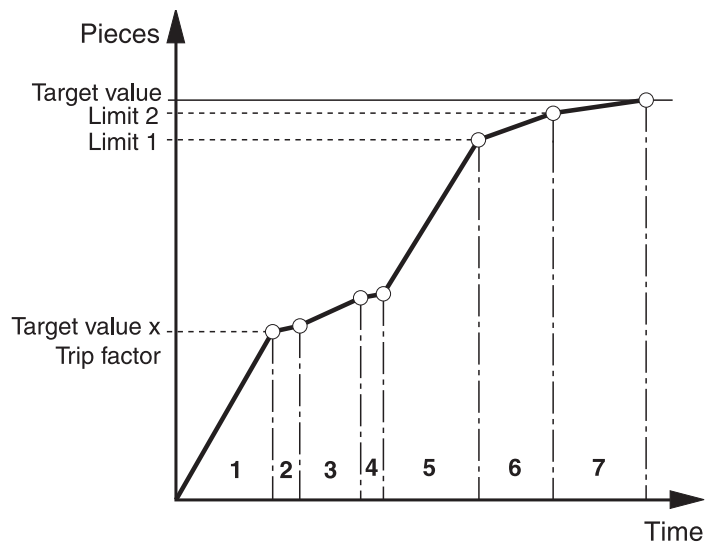

### 2.2.3 Specify reference value and dispensing parameters

#### With fixed target values

##### Apply fixed target values

1. Enter number of fixed target values: 1 ... 999.
2. Press REF G key.  
Display briefly shows piece designation and piece weight, as well as the dispensing parameters from respective memory and then current number of pieces with unit PCS.  
The ID7-Count is in the READY FOR DISPENSING state.

##### Enter article number

If ARTICLE NUMBER ON is selected in the master mode, then the reference weight and dispensing parameters can be displayed by entering the article number.  
If a barcode reader is also connected, then the reference weight and dispensing parameters can be read in with the barcode reader.

→ Press the CODE A key and enter the article number.

– or –

→ Read in the article number directly with the barcode reader.

Display briefly shows piece designation and piece weight, as well as the dispensing parameters from respective memory and then current number of pieces with unit PCS.

The ID7-Count is in the READY FOR DISPENSING state.

#### Notes

- If no reference values are stored for the article number, the message NEW ARTICLE appears. The reference weight and name of the article can be entered and stored as new constants.
- If REFERENCE WEIGHT UPDATE ON is selected in the master mode, then the reference weight can be changed after displaying the article.

#### Manual

##### 1. Specify reference value

##### Standard reference quantity

1. Place reference pieces on or remove from the weighing platform in accordance with the standard reference quantity, e. g. 10 pieces (factory setting).
2. Press REF 10 key.  
The display shows STD REF 10 PCS and then the current quantity in PCS, here 10 PCS.

#### Note

The standard reference quantity can be set in the master mode, see section 3.1.2.

**Variable  
reference quantity**

1. Place any number of reference pieces on the weighing platform or remove as many reference pieces from it as desired.
2. Press REF N key  
VAR REF \_ PCS appears in display.
3. Enter the quantity in accordance with the reference pieces placed on the weighing platform or removed from it and confirm with ENTER.  
As long as no stability is reached, REF DETERMINATION appears in display, then number of reference pieces in PCS.

**Enter reference piece  
weight numerically**

1. Press REF W key.
2. Enter the known piece weight of a reference piece in the displayed unit and confirm with ENTER.

**Notes**

- The weight unit for entering the reference piece weight can be selected with the FUNCTION CHANGE key.
- The entry can be corrected one character at a time with the CLEAR key.

**Monitoring the  
reference weight**

If the display indicates ADD ... PCS or REF WEIGHT TOO LOW, the minimum reference weight is dropped below, see section 2.4.

→ Lay additional reference pieces on the weighing platform and confirm with ENTER.

**2. Enter dispensing parameters**

- Press the LIMIT key and enter the following values:
- Enter the target quantity and confirm with ENTER.
  - Enter limits LIM 1 and LIM 2 and confirm with ENTER.  
Without specification the limits are determined automatically.
  - Enter tolerances TOL+ and TOL– and confirm with ENTER.  
The display shows READY FOR DISPENSING.

**2.2.4 Delete reference value and end piece-filling application**

- Press REF N or REF W key and delete the reference value with the CLEAR key.  
The display changes to the normal weight display.

### 2.2.5 Piece-filling

After entering the filling parameters, the function keys switch over to the following assignment:

START	STOP	CONF	–	TOTAL	LIMIT
Start filling process	Stop filling process	Confirm manual refilling	–	Display and print total quantity	Enter filling parameters and print

The filling type is dependent on the settings in the master mode, see section 3.1.3. Either additive or subtractive weighing is possible.

#### Additive weighing

With additive weighing a container on the weighing platform is filled from the supply vessel.

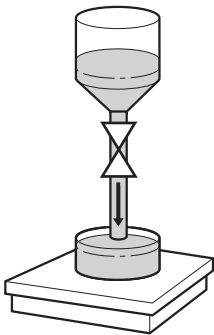

- Place an empty container on the weighing platform and tare the weighing platform.
- Press the (external) START key.  
The display shows the number of pieces and the filling status (coarse feed ▼▼▼, fine feed ▼).  
When the filling process is ended, the display shows whether the weight value lies within the tolerances (CORRECT) or outside (SURPLUS or DEFICIT).  
The filling result is printed.
- Relieve weighing platform.  
The display shows READY FOR DISPENSING.

#### Subtractive weighing

With subtractive weighing a container is filled from the supply vessel on the weighing platform.

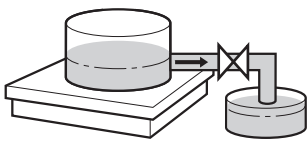

- Place the filled supply vessel on the weighing platform and tare the weighing platform.
- Press the (external) START key.  
The display shows the number of pieces and the filling status (coarse feed ▼▼▼, fine feed ▼). When the filling process is ended, the display shows whether the weight value lies within the tolerances (CORRECT) or outside (SURPLUS or DEFICIT).  
The filling result is printed.
- Relieve weighing platform.  
The display shows READY FOR DISPENSING.

#### Note

During subtractive weighing the quantity is displayed with a negative sign.



### 2.2.6 Manual recorection

#### Prerequisite

REFILLING OFF is set in the master mode, otherwise refilling takes place automatically in the case of underfilling.

1. If the display shows SURPLUS or DEFICIT, correct the quantity manually.
2. If the display shows CONFIRM, press the CONF or external START key.

### 2.2.7 Interrupt filling process

1. Press the (external) STOP key. The filling process is interrupted.
2. To continue the filling process, press the (external) START key.

### 2.2.8 Cancel filling process

→ Press (external) STOP key twice. The filling process is cancelled.

### 2.2.9 End filling process

→ Press (external) STOP key in READY FOR DISPENSING state.  
The display changes to the normal weight display.

### 2.2.10 Totalizing

The AUTO TOTALIZE master mode block (see section 3.1.3) specifies whether totalizing is automatic.

If ITEM COUNTER is used (see section 3.1.2), the filling system automatically stops when the stop value is reached.

1. Carry out 1st filling process, see section 2.2.5.
2. If AUTO TOTALIZE ON is set in the master mode, the quantity of the current item is added to the sum.
3. Relieve weighing platform.
4. Carry out additional filling processes, see steps 1 to 3.
5. To display and print the total, press the SUM key.  
The total quantity is displayed and printed.
6. To carry out filling processes with other piece goods or end totalizing: press the SUM, CLEAR key sequence.

#### Note

ID7-Count totalizes the gross, net and tare values of the items internally. These sums can be read via the application blocks 315, 316 and 362.

## 2.3 NEUTRAL MEASUREMENT application

With the NEUTRAL MEASUREMENT application the ID7-Count derives other physical variables, e. g. length, area, volume, from a weight value following specification of a reference value. For example, the length of a cable can be determined from the related weight value.

The unit and format of the physical variable are set in the master mode, see section 3.1.4.

### Prerequisite

The NEUTRAL MEASUREMENT application is selected in the master mode.

### Function keys

In the NEUTRAL MEASUREMENT application the function keys are assigned as follows:

REF 10	REF N	REF W	PLUS	SUM	← →
Copy standard reference variable. Factory setting: 10 units	Enter variable reference variable	Enter reference weight	Totalize variable values (e. g. length)	Display and print total value of the variable (e. g. length)	Switch back and forth between total value of variable (e. g. length) and value of current item

→ Select the function by pressing the function key.

### Example

→ Press the REF N key.

Then enter the reference variable manually with the keypad.

### When the function keys are otherwise allocated

→ Press the FUNCTION CHANGE key until the function keys allocation displayed above appears.

### 2.3.1 Specify reference value

#### Standard reference variable

1. Place reference pieces on or remove from the weighing platform in accordance with the standard reference quantity, e. g. 10 pieces (factory setting).
2. Press REF 10 key.  
The display shows STD REF 10 PCS and then the current variable with unit, e. g. 10 m.

#### Note

The standard reference variable can be entered in the master mode under STANDARD REF-PCS, see section 3.1.2.

**Variable reference variable**

1. Place reference pieces of any known variable (e. g. 1.25 m long cable) on or remove from the weighing platform.
2. Press REF N key.
3. Enter the variable in accordance with the reference piece (here 1.25) and confirm with ENTER.  
The display shows VAR REF and then the current variable with unit, here 1.25 m.

**Enter reference piece weight numerically**

1. Press REF W key.
2. Enter the known piece weight of a reference piece (e. g. 1 m long cable) in the displayed weight unit and confirm with ENTER.

**Notes**

- The weight unit for entering the reference piece weight can be selected with the FUNCTION CHANGE key.
- The entry can be corrected one character at a time with the CLEAR key.

**Copy reference piece weight constants**

1. Enter the number of the reference weight memory: 1 ... 999.
2. Press REF W key.  
The display shows the piece weight from the respective memory.

**Enter article number**

If ARTICLE NUMBER ON is selected in the master mode, then the reference weight can be displayed by entering the article number.  
If a barcode reader is also connected, then the reference weight can be read in with the barcode reader.

→ Press the CODE A key and enter the article number.

– or –

→ Read in the article number directly with the barcode reader.

Display briefly shows piece designation and piece weight from respective memory and then current variable with unit.

**Notes**

- If no reference values are stored for the article number, the message NEW ARTICLE appears. The reference weight and name of the article can be entered and stored as new constants.
- If REFERENCE WEIGHT UPDATE ON is selected in the master mode, then the reference weight can be changed after displaying the article.

**Monitoring the reference weight**

If the display indicates ADD ... or REF WEIGHT TOO LOW, the minimum reference weight is dropped below, see section 2.4.

→ Lay additional reference pieces on the weighing platform and confirm with ENTER.

### 2.3.2 Delete reference value or end NEUTRAL MEASUREMENT application

- Press the REF N or REF W key and delete the reference variable with the CLEAR key.  
The display changes to the normal weight display.

### 2.3.3 Neutral measurement

With neutral measurement a container is filled with a certain content.

1. Place an empty container on the weighing platform and tare the weighing platform.
2. Specify a reference value, see section 2.2.3.
3. Lay the weighing sample on the weighing platform.  
The variable value (e. g. length) is displayed with unit (max. 3 characters).

### 2.3.4 Totalizing

Items of the same material can be totalized as follows:

1. Specify a reference value, see section 2.2.3.
2. Place the 1st item on the weighing platform and press the PLUS key.  
The display shows the value of the physical variable (e. g. length) with unit, e. g. 1.25 m.
3. Relieve weighing platform.
4. Lay additional items on the weighing platform consecutively and repeat steps 1 and 2.  
The display shows the number of totalized items and the total value of the variable, e. g. 6.71 m.
5. To switch back and forth between the total value of all items and the value of the current item, press the ← → key.
6. Press key SUM.  
The total value of the variable (e. g. length) is displayed and printed.
7. To end totalizing, press the SUM, CLEAR key sequence.  
The sum is cleared and the item counter is reset.

#### Notes

- ID7-Count totalizes the gross, net and tare values of the items internally. These sums can be read via the application blocks 315, 316 and 362.
- If CLEARING OF TOTAL ON is set in the master mode, a new reference value cannot be entered until the old sum is cleared. If the sum is not cleared yet, the message CLEARING OF TOTAL appears.

## 2.4 Monitoring reference weight

The ID7-Count checks whether the total weight of the reference pieces is less than a minimum reference weight. If the minimum reference weight is dropped below, the display shows a message dependent on the settings in the master mode.

**ADD MODE ON** If the minimum reference weight is dropped below and ADD MODE ON is set in the master mode, the display shows ADD ... PCS or ADD ... .

→ Place additional reference pieces on the weighing platform and confirm with ENTER.

The display shows REF DETERMINATION and then the current quantity or variable.

– or –

→ To count with the original reference quantity, press the REF N key again.

The display shows the quantity or variable with an asterisk:

\* ... PCS or \* ...

**ADD MODE OFF** If the minimum reference weight is dropped below and ADD MODE OFF is set in the master mode, the display shows the quantity or variable with an asterisk: \* ... PCS or \* ...

### Note

If the reference weight placed on the platform is less than 10 % of the minimum reference weight, the display shows REF WEIGHT TOO LOW.

→ Place additional reference pieces on the weighing platform and determine the reference value again.

## 2.5 Automatic reference optimization

The larger the reference quantity or the reference variable is, the more exactly the ID7-Count determines the quantity or the physical variable (e. g. length) from it.

If REF. OPTIMIZATION ON is set in the master mode, the counting accuracy can be improved. Here the following should be observed:

- The displayed and the actual reference quantity or reference variable must match.
- The new reference quantity or reference variable may be a maximum of twice as large as the stored quantity.
- The entire weight of the reference parts may not exceed the upper limit specified in the master mode; factory setting: 4 %.

→ Increase the displayed reference quantity or reference variable by placing additional reference pieces on the platform.

The display shows REF. OPTIMIZATION and then the new reference quantity or reference variable.

## 2.6 Statistical evaluation of reference pieces

The weight of apparently identical reference pieces is subject to a smaller or larger deviation on which the counting accuracy is dependent.

The ID7-Count determines the mean value, standard deviation, minimum and maximum, and the number of reference pieces for the piece weight of the reference pieces, see application block 392 ... 396 in section 4.1. Here the following should be observed:

- Use the weighing platform with the highest resolution.
  - The piece weights must be greater than 1 digit.
1. Place an empty container on the weighing platform.
  2. Press the REF W key, enter a piece weight of 0 and confirm with ENTER.  
The container is automatically tared and the statistics function started.
  3. When the display shows LOAD SAMPLE 1, place the first reference piece on the weighing platform.  
The piece weight is copied and tared away.
  4. When the display shows LOAD SAMPLE X, place additional reference pieces on the weighing platform.  
If the piece weight deviates from the previous mean value by more than 50 %, the display shows WRONG SAMPLE.  
The piece weight is copied and tared away in each case.
  5. To end the statistical evaluation: press the ENTER key.  
The display shows the quantity or the variable (e. g. length) of the reference pieces and copies this value as the reference value for the next counting process.

### Note

The statistical evaluation can be cancelled with the CLEAR key.

## 2.7 Counting with the DeltaTrac

The DeltaTrac is an analog display which simplifies reading off, see "Additional functions" chapter of the operating instructions and installation information for the ID7... weighing terminal. Instead of a target weight, a target quantity or the target value of a physical variable is specified for counting.

**Limits** The following limits apply for the DeltaTrac applications FILLING and CLASSIFYING:

- Minimum value: 10 PCS or 10
- Maximum value: 1'000'000 PCS or 1'000'000
- Minimum tolerance: 1 PCS or 1
- Maximum tolerance:
  - 10 % for the DeltaTrac application FILLING,
  - 50 % for the DeltaTrac application CLASSIFYING,
  - there are no limits for the DeltaTrac application CHECKWEIGHING.

### Notes

- DeltaTrac target values cannot be entered until the reference value has been determined.
- The display shows ignored limits, e. g. MIN-DEL = ... PCS, when the target quantity entered was too small.
- When starting a new counting process, the target quantity or the target value is automatically deleted.

## 2.8 Working with several weighing platforms

When several weighing platforms are connected to the ID7-Count, the reference pieces can be weighed on a reference weighing platform with a higher resolution and the weighing sample counted on a different quantity weighing platform. In the process, the ID7-Count automatically switches back and forth between the two weighing platforms.

In the master mode a preferred reference weighing platform can be selected. The weighing platform with the highest resolution is considered the preferred reference weighing platform in the default configuration, see section 3.1.2.

### 2.8.1 Counting with (preferred) reference weighing platform and quantity weighing platform

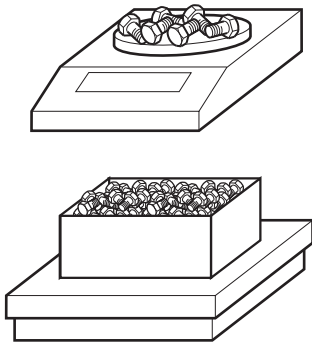

1. Place reference pieces on the (preferred) reference weighing platform with a higher resolution.
2. Press the REF 10 or REF N key.  
The reference weight is automatically determined on the (preferred) reference weighing platform.  
Then the ID7-Count automatically switches over to the quantity weighing platform last selected.
3. Place the weighing sample on the quantity weighing platform last selected for counting.

### 2.8.2 Counting only on reference weighing platform

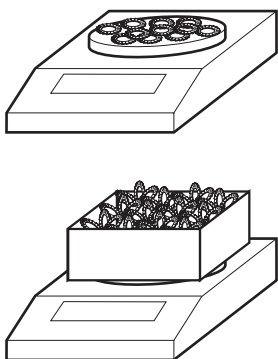

If small pieces in small quantities must be counted, it is advisable to carry out reference determination and weighing on the reference weighing platform.

1. Select the reference weighing platform, see section 2.5 in the operating instructions and installation information for the ID7... weighing terminal.
2. Place reference pieces on the (preferred) reference weighing platform with a higher resolution.
3. Press the REF 10 or REF N key.  
The reference weight is automatically determined on the (preferred) reference weighing platform.
4. Count the weighing sample on the (preferred) reference weighing platform.

### 2.8.3 Counting only on quantity weighing platform

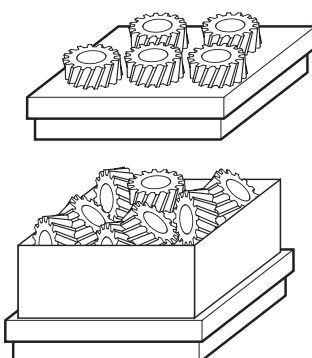

If large pieces must be counted, it is advisable to carry out reference determination and weighing on the quantity weighing platform.

1. Place reference pieces on the quantity weighing platform.
2. Enter the weighing platform number of the quantity weighing platform and press the REF 10 or REF N key.  
The reference weight is determined on the quantity weighing platform.
3. Count the weighing sample on the quantity weighing platform.



## 2.9 PE balance as reference balance

### Conditions

- Interface CL20mA-ID7 installed on ID7 Count in setting transmission and reception loop active.
- Following settings in master mode block CL20mA apply to affected interface CL20mA-ID7:
  - Communication            STANDARD
  - Dialog mode                ON
  - PE send continuous        ON
- PE balance connected with connection cable AWG Option and PE/CL Adapter 22 003 029.

### Notes on operation

- PE balance cannot be selected as a quantity scale. It can only be operated as a reference scale.
- If a PE balance is connected, it is automatically the preferred reference balance, regardless of which preferred reference scale is set in master mode.
- Reference optimisation, statistic function and ADD mode are not possible with PE balance; lowest counting limit is 1 d.
- Only one PE balance can be connected.

## 2.10 Recall application-specific information

Information for counting can be recalled with the following key combinations:

INFO, REF 10	Standard reference quantity or standard reference variable
INFO, REF N	Variable reference quantity or variable reference variable
INFO, REF W	Current reference weight
INFO, No., REF W	Reference weight memory No. XXX
INFO, SUM	Current sum
INFO, LIMIT	Current filling parameters for the PIECE-FILLING application
INFO, No., LIMIT	Limit memory No. XXX for the PIECE-FILLING application
INFO, CODE A	Factory setting: Article number
INFO, CODE B	Factory setting: Order number
INFO, CODE C	Factory setting: Code number
INFO, CODE D	Factory setting: Document number

### Note

If several pieces of information are recalled with one key, the display changes automatically after the set DISPLAY DURATION. You can also switch back and forth between these pieces of information with the CLEAR key.

## 3 Settings in the master mode

### 3.1 PAC master mode block

#### 3.1.1 Overview of the PAC master mode block

In the PAC master mode block the following system settings can be carried out:

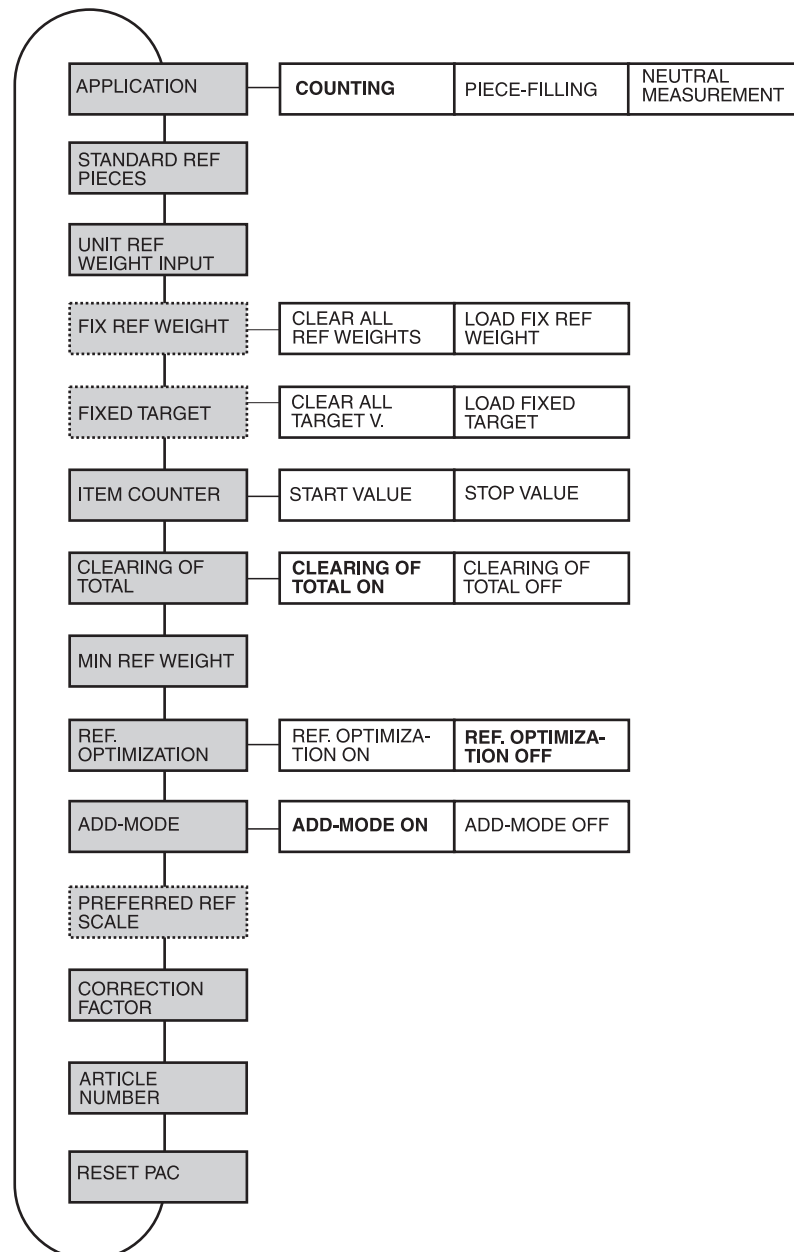

- Legend**
- Blocks on a **grey** background are described in detail in the following.
  - Factory settings are shown in **bold** print.
  - Blocks which only appear under certain conditions have a **dotted outline**.

### 3.1.2 Settings in the master mode block PAC

#### Note

You can make all master mode adjustments conveniently with the PC using the CountTool software. Ask your METTLER TOLEDO sales partner. See section 3.1.5 for examples.

APPLICATION	Select application
COUNTING	Normal counting (factory setting).
PIECE-FILLING	Automatic filling of a specified target quantity; for additional settings see section 3.1.3.
NEUTRAL MEASUREMENT	Derive other physical variables from the weight value, e. g. length, area, volume; for additional settings see section 3.1.4.

STANDARD REF PIECES	Enter standard reference quantity or standard reference variable
STD REF	Possible values: 1 ... 9999 (factory setting: 10), in the application NEUTRAL MEASUREMENT max. 8 characters including decimal point (e.g. 999.9999)
Comments	<ul style="list-style-type: none"> <li>The STD REF is specified in PCS for the COUNTING and PIECE-FILLING applications.</li> <li>The data format and unit are specified in the master mode for the NEUTRAL MEASUREMENT application, see section 3.1.4.</li> </ul>

UNIT REF WEIGHT INPUT	Select the preferred unit for the reference weight
UNIT	Possible units: mg, g, kg, lb, ozt, oz. Factory setting: g for 1st weight unit kg, oz for 1st weight unit lb.

FIX REF WEIGHT	Save fixed reference piece weights in the reference piece weight memories
	Only for the applications COUNTING and NEUTRAL MEASUREMENT.
LOAD FIX REF WEIGHT	The contents of the reference-piece weight memories (001 ... 999) are displayed clearly laid out on a display page for each memory number. The reference piece weights can be entered with the function keys and the numeric keypad. For the function key assignment, see the next page.
CLEAR ALL REF WEIGHTS	Clear all reference piece weight memories.

**Parameters** The following parameters are shown in the display for LOAD FIX REF WEIGHT (example):

REF017:	2 g
NAME:	M8 BOLT
ART #:	123456

REF017: 2 g Reference piece weight for memory number 017, here 2 grams  
 NAME: Article name, alphanumeric, max. 20 characters, here M8 BOLT  
 ART #: Article number, alphanumeric, max. 20 characters, here 123456

FIXED TARGET	Save fixed target values for piece-filling in the target memories
	Only for the PIECE-FILLING application.
LOAD FIXED TARGET	The contents of the target memories (001 ... 999) are displayed clearly laid out on a display page for each memory number. The dispensing parameters can be entered with the function keys and the numeric keypad. For the function key assignment, see the next page.
CLEAR ALL TARGET V.	Clear all target memories.

**Parameters** The following parameters are shown in the display for LOAD FIXED TARGET (example):

REF017:	2 g	(M8 BOLT )
S :	2500 PIECES	A #: 123456
L1 :	2000 PIECES	T- : 5 PIECES
L2 :	2400 PIECES	T+ : 10 PIECES

REF017: 2 g Reference piece weight for memory number 017, here 2 grams  
 S Target pieces, here 2500 pieces  
 (...) Article name, alphanumeric, max. 20 characters, here M8 BOLT  
 A #: Article number, alphanumeric, max. 20 characters, here 123456  
 L1 Switchover point for coarse/fine feed (Limit 1), here 2000 pieces  
 If Limit 1 is to be automatically determined in learn mode:  
 no entry  
 L2 Switch-off point for fine feed (Limit 2), here 2400 pieces  
 LIMIT 1 < LIMIT 2.  
 If Limit 1 and Limit 2 are to be determined in learn mode:  
 no entry  
 TOL- Negative tolerance, here 5 pieces  
 TOL+ Positive tolerance, here 10 pieces

**Function keys** The function keys are assigned as follows for LOAD FIX REF WEIGHT and LOAD FIXED TARGET:

<->	<	>	F▶	EDIT	↑
Select parameters	Display previous memory	Scroll through memory numbers: Increasing	Select assignment of function key F5	EDIT GO DEL	Return to higher level

EDIT Changes to input mode for marked parameters.

GO Opens desired memory.

DEL Deletes memory.

<b>ITEM COUNTER</b>	<b>Enter item counter for all items which will be added with the PLUS key</b>
START VALUE	Possible values: 1 ... 9999 (factory setting: 1)
STOP VALUE	Possible values: 1 ... 9999 (factory setting: 9999)

<b>CLEARING OF TOTAL</b>	<b>Switch automatic clearing of the sums on or off when starting a new counting process</b>
	Factory setting: CLEARING OF TOTAL ON

<b>MIN REF WEIGHT</b>	<b>Set minimum reference weight</b>
	Factory setting: second-smallest permissible value
MIN W X	Increase the minimum reference weight of the weighing platform X in the displayed unit by the factor 10, 20, 50 or 100.

<b>REF. OPTIMIZATION</b>	<b>Switch automatic reference optimization on or off</b>
	If REF. OPTIMIZATION ON is set, the counting accuracy can be increased by placing additional reference pieces on the scale. The new reference quantity or reference variable may be a maximum of twice as large as the quantity/variable last saved. Factory setting: REF. OPTIMIZATION OFF.
MAX. LIMIT	Enter the upper limit in % of the maximum load of the weighing platform up to which optimisation is to be carried out. Possible settings: 1 ... 100 % Factory setting: 4 %

ADD-MODE	Switch the add-mode on or off
	<p>If ADD-MODE ON is set, the weight of all reference pieces is compared to the minimum reference weight and the missing quantity is determined.</p> <ul style="list-style-type: none"> <li>• ADD-MODE ON (factory setting): If the current reference weight is less than the minimum reference weight, the display shows ADD ... PCS or ADD ... and counting can not be commenced until the required reference pieces have been placed on the weighing platform.</li> <li>• ADD-MODE OFF: If the current reference weight is less than the minimum reference weight, the display shows * ... PCS or * ... and counting can be commenced immediately.</li> </ul>
Comment	<p>If the current reference weight is less than 10 % of the minimum reference weight, the display shows REF WEIGHT TOO LOW.</p> <p><b>Example:</b> Minimum reference weight 10 g. The message REF WEIGHT TOO LOW appears when the reference weight placed on the weighing platform weighs less than 1 g.</p>

PREFERRED REF SCALE	Select preferred reference weighing platform for determining reference value
	<p>Only possible when several weighing platforms are connected. Factory setting: weighing platform with highest resolution.</p>

CORRECTION FACTOR	Enter the correction factor for the quantity or the value of the physical variable (e. g. length)
	<p>The quantity or the value of the physical variable (e. g. length) is calculated from the current reference piece weight and the weight of all pieces, multiplied by the correction factor and the result displayed. Access is protected with a code. Possible factors: 0.10 ... 10.00 in steps of 0.01 (factory setting: 1.00)</p>
CODE	Specify the access code.
Comments	<ul style="list-style-type: none"> <li>• With a correction factor &lt; 1.00 a sufficient quantity or a sufficient value of the physical variable (e. g. length) is always achieved.</li> <li>• If a correction factor other than 1.00 is entered, the unit of the quantity is marked: "PCS" becomes "PC.".</li> </ul>

ARTICLE NUMBER	Activate or deactivate display of reference weight memory with article number
	<p>If ARTICLE NUMBER ON is selected, you can start counting by entering the article number.</p> <p>If a barcode reader is also connected, then the reference weight can be read in with the barcode reader.</p> <p>Factory setting: ARTICLE NUMBER OFF</p>
FIX REF WEIGHT UPDATE	<p>If FIX REF WEIGHT UPDATE ON is selected, a new reference weight can be entered in the weighing mode after displaying the read-only memory.</p> <p>Factory setting: FIX REF WEIGHT UPDATE OFF</p>
AUTO REPLACE	<p>If AUTO REPLACE ON is selected, the oldest memory entry is cleared to create space for the new article when the article memory is full.</p>

RESET PAC	Reset functions to factory setting	
	<p><b>Block</b></p> <p>APPLICATION</p> <p>STANDARD REF PIECES</p> <p>UNIT REF WEIGHT INPUT</p> <p>ITEM COUNTER</p> <p>CLEARING OF TOTAL</p> <p>MIN REF WEIGHT</p> <p>REF. OPTIMIZATION</p> <p>ADD-MODE</p> <p>PREFERRED REF SCALE</p> <p>CORRECTION FACTOR</p> <p>ARTICLE NUMBER</p> <p>FIX REF WEIGHT UPDATE</p>	<p><b>Factory setting</b></p> <p>counting</p> <p>10</p> <p>g for main unit kg; oz for main unit lb</p> <p>start value 1, stop value 9999</p> <p>on</p> <p>second smallest, permissible value</p> <p>off</p> <p>on</p> <p>weighing platform with highest resolution</p> <p>1.00</p> <p>off</p> <p>off</p>

### 3.1.3 PIECE-FILLING application

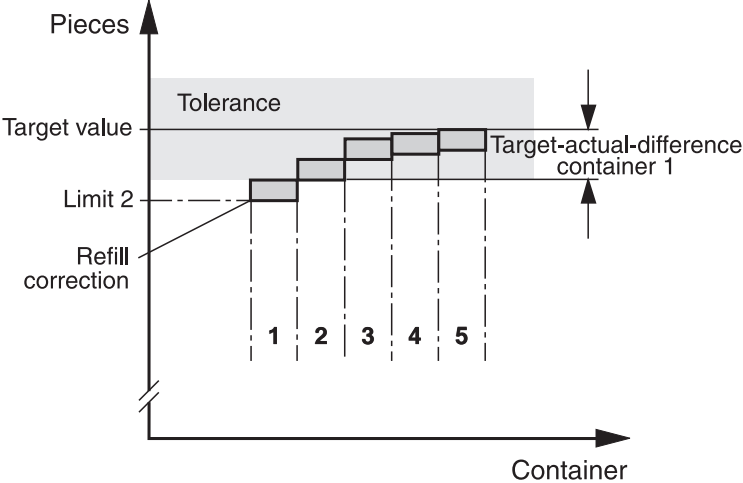
PIECE-FILLING	Automatic filling when specifying a target value
FILLING TYPE	Possible settings: <ul style="list-style-type: none"> <li>• WEIGHING-IN</li> <li>• SUBTRACTIVE WEIGHING</li> </ul>
AUTO TOTALIZE	<b>Switch automatic totalizing after each filling process on or off</b>
AUTOMATIC TARE	<b>Switch automatic taring on or off during each filling process</b>
REFILL CORRECTION	<p><b>Switch refill correction on or off</b></p> <p>The refill correction optimizes the switch-off point of the fine feed (limit 2). The difference between the target and actual value (target-actual difference) is determined for the 1st container and multiplied with a FACTOR. Limit 2 is automatically corrected by this value <math>\Delta</math> when filling the next container:</p> $\Delta = \text{FACTOR} \times \text{target-actual difference}$ <p>Example: For a target-actual difference of 10 PCS and a FACTOR of 0.5, limit 2 is corrected by 5 PCS.</p> <p>Limit 2 is corrected until the quantity of a container matches the target value.</p>  <p>The more unstable the material flow is, the lower the factor should be. Possible entries for the FACTOR: 0.0 ... 0.9</p>
SAFETY FACTOR	<p>The safety factor specifies how long the fine feed is open in the learn mode. The larger the safety factor, the more accurately the fine feed run-on can be determined.</p> <p>Possible settings: SAFETY FACTOR = 1.0 ... 1.9 (factory setting: 1.5)</p>

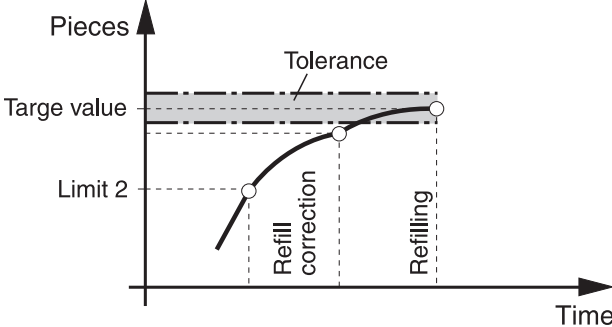

PIECE-FILLING	Automatic filling when specifying a target value
REFILLING	<p><b>Switch automatic refilling on or off</b></p> <p>If the quantity briefly overshoots, the fine feed is switched off too early and the current quantity lies below the target value. During refilling the fine feed is opened again in intervals until the target value is reached.</p>  <p>Possible entries:</p> <ul style="list-style-type: none"> <li>• PULSE DURATION – The fine feed is opened during the pulse duration. Possible values: 1 ... 9 in intervals of 230 milliseconds</li> <li>• PULSE PAUSE – The fine feed is switched off during the pulse pause. Possible values: 0 ... 9 in intervals of 230 milliseconds</li> </ul>
Comment	For the terminal diagram and terminal assignment for the 8-ID7 relay box, see section 7.1.

### 3.1.4 NEUTRAL MEASUREMENT application

NEUTRAL MEASUREMENT	Derive other physical variables, e. g. length, area, volume, from the weight value
FORMAT	<p><b>Set the representation of the physical variable</b></p> <p>Possible formats: 0; 0.0; 0.00; 0.000</p>
TEXT	<p><b>Set the denomination of the physical variable</b></p> <p>Possible entries: enter a maximum of 10 characters and confirm with the ENTER key, e. g. "Contents".</p>
UNIT	<p><b>Enter the unit of the physical variable</b></p> <p>Possible entries: enter a maximum of 3 characters and confirm with the ENTER key, e. g. m, cm, mm, lit, ccm, etc.</p>

### 3.1.5 CountTool

CountTool is a free configuration and editing tool for ID7-Count which runs on every PC. It communicates with the ID7-Count via a serial interface or Ethernet/WLAN and enables convenient configuration and data management, monitoring and conversion from and to ACCESS databases.

Please ask METTLER TOLEDO Customer Service about CountTool.

#### Setting parameters

All the mastermode settings can be made on a screen with CountTool in a clear and concise manner.

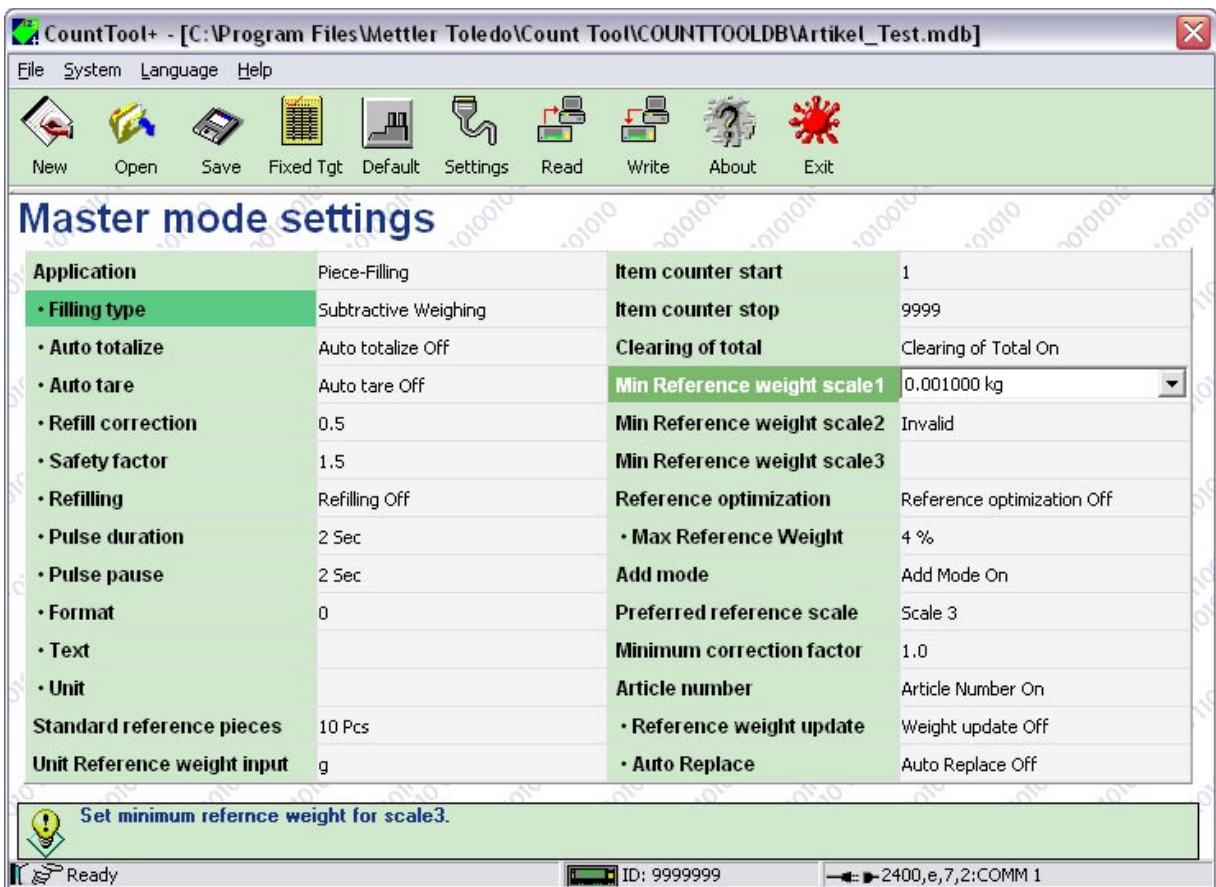

### Editing fixed values

Fixed values can be edited easily with CountTool.

CountTool+ - [C:\Program Files\Mettler Toledo\Count Tool\COUNTTOOLDB\Artikel\_Test.mdb]

File System Language Help

New Open Save Master Md Default Settings Read Write About Exit

### Fixed Target Entries - Piece-Filling

Index	Article Number	Name	Ref Weight	Target(Pcs)	Limit1(Pcs)	Lir
1	1244322344	Artikel_001	0.234 kg	469	340	460
2	7889785543	Artikel_002	0.445 kg	500	300	400
3	3345225343	Artikel_003	0.884 kg	1300	1000	1250
4	8789712332	Artikel_004	1.345 kg	20	14	19
5	9923123333	Artikel_005	0.231 kg	3000	2400	2900
6						
7						
8						
9						
10						
11						
12						

Press F2 to Edit, F3 to Save, F4 to Delete and F5 to cancel.

Ready ID: 9999999 2400,e,7,2:COMM 1

## 4 Application blocks

In the following description, the application blocks are shown in the syntax for the MMR command set. When used with the SICS command set, please observe the SICS conventions, see Operating instructions and installation information for ID7... weighing terminal.

### 4.1 PAC application blocks

No.	Content	Format
301	Pac version	Response: <code>A,B _ I,D, / ,C,o,u,n,t,P,a,c, _ x . x x</code>
302	Program number	Response: <code>A,B _ I,P,0,3,-,0,-,0,x,x,x _</code>
307_001 ... 307_999	Article numbers for read-only memories 332_001... 332_999	Response: <code>A,B _ Text_20</code> Write: <code>A,W 3,0,7 _ x,x,x Text_20</code> Comment: xxx = 001 ... 999 Only when ARTICLE NUMBER ON is selected in the master mode.
310	Current quantity	Response: <code>A,B _ Number_10 _ Unit</code> Unit = PCS Comment: for COUNTING and PIECE-FILLING applications
311	Current piece weight/ current dispensing parameters	Response: COUNTING and NEUTRAL MEASUREMENT <code>A,B _ Text_20 _ _ Weight value _ Unit</code> PIECE FILLING <code>A,B _ Name (Text_20) _ _</code> <code>Piece weight (weight value) _ Unit _ _</code> <code>Target pieces (Number_10) _ Unit _ _</code> <code>Limit 1 (Number_10) _ Unit _ _</code> <code>Limit 2 (Number_10) _ Unit _ _</code> <code>Tolerance(-) (Number_10) _ Unit _ _</code> <code>Tolerance(+) (Number_10) _ Unit</code> Write: COUNTING and NEUTRAL MEASUREMENT <code>A,W 3,1,1 _ Text_20 \$,\$ Weight value _ Unit</code> PIECE FILLING <code>A,W 3,x,x _ Name (Text_20) \$,\$</code> <code>Piece weight (weight value) _ Unit \$,\$</code> <code>Target pieces (Number_10) _ Unit \$,\$</code> <code>Limit 1 (Number_10) _ Unit \$,\$</code> <code>Limit 2 (Number_10) _ Unit \$,\$</code> <code>Tolerance(-) (Number_10) _ Unit \$,\$</code> <code>Tolerance(+) (Number_10) _ Unit</code> Note: Start counting, as with REF W key

No.	Content	Format
312	Reference quantity or reference variable	Response: <input type="text" value="A"/> <input type="text" value="B"/> <input type="text" value="Number_10"/> <input type="text" value="Unit"/> Write: <input type="text" value="A"/> <input type="text" value="W"/> <input type="text" value="3"/> <input type="text" value="1"/> <input type="text" value="2"/> <input type="text" value="Number_10"/> <input type="text" value="Unit"/> Comment: Start counting, as with REF N key for the COUNTING and PIECE-FILLING applications, the reference quantity is displayed with unit = PCS for the NEUTRAL MEASUREMENT application the reference variable is displayed without a unit, and decimal places are also possible
313	Item counter	Response: <input type="text" value="A"/> <input type="text" value="B"/> <input type="text" value="Number_4"/>
314	Sum of quantity or sum of physical variable (e. g. length)	Response: <input type="text" value="A"/> <input type="text" value="B"/> <input type="text" value="Number_10"/> <input type="text" value="Unit"/> Comment: for the COUNTING and PIECE-FILLING applications the sum is displayed with unit = PCS for the NEUTRAL MEASUREMENT application the sum is displayed without a unit
315	Sum net weight	Response: <input type="text" value="A"/> <input type="text" value="B"/> <input type="text" value="Weight value"/> <input type="text" value="Unit"/>
316	Sum gross weight	Response: <input type="text" value="A"/> <input type="text" value="B"/> <input type="text" value="Weight value"/> <input type="text" value="Unit"/>
317	Standard reference quantity or standard reference variable	Response: <input type="text" value="A"/> <input type="text" value="B"/> <input type="text" value="Number_10"/> <input type="text" value="Unit"/> Write: <input type="text" value="A"/> <input type="text" value="W"/> <input type="text" value="3"/> <input type="text" value="1"/> <input type="text" value="7"/> <input type="text" value="Number_4"/> <input type="text" value="Unit"/> Comment: for the COUNTING and PIECE-FILLING applications the standard reference quantity is displayed with unit = PCS for the NEUTRAL MEASUREMENT application the standard reference variable is displayed without a unit, and decimal places are also possible
318 ... 321	Identification data Code A ... Code D	Response: <input type="text" value="A"/> <input type="text" value="B"/> <input type="text" value="Name (text_20)"/> <input type="text" value="Identification (text_20)"/> Write: <input type="text" value="A"/> <input type="text" value="W"/> <input type="text" value="3"/> <input type="text" value="x"/> <input type="text" value="x"/> <input type="text" value="Name (text_20)"/> <input type="text" value="\$"/> <input type="text" value="\$"/> <input type="text" value="Identification (text_20)"/> Comment: xx = 18 ... 21; corresponds to the application blocks 094 ... 097
322 ... 324	Minimum reference weight weighing platform 1 ... 3	Response: <input type="text" value="A"/> <input type="text" value="B"/> <input type="text" value="Weight value"/> <input type="text" value="Unit"/> Write: <input type="text" value="A"/> <input type="text" value="W"/> <input type="text" value="3"/> <input type="text" value="2"/> <input type="text" value="x"/> <input type="text" value="Weight value"/> <input type="text" value="Unit"/> Comment: x = 2 ... 4
325 ... 327	Counter limit weight weighing platform 1 ... 3	Response: <input type="text" value="A"/> <input type="text" value="B"/> <input type="text" value="Weight value"/> <input type="text" value="Unit"/>
328	Start value item counter	Response: <input type="text" value="A"/> <input type="text" value="B"/> <input type="text" value="Number_4"/> Write: <input type="text" value="A"/> <input type="text" value="W"/> <input type="text" value="3"/> <input type="text" value="2"/> <input type="text" value="8"/> <input type="text" value="Number_4"/>
329	Unit reference weight for entering the piece weight	Response: <input type="text" value="A"/> <input type="text" value="B"/> <input type="text" value="Unit"/> Write: <input type="text" value="A"/> <input type="text" value="W"/> <input type="text" value="3"/> <input type="text" value="2"/> <input type="text" value="9"/> <input type="text" value="Unit"/>
330	Sum quantity without unit	Response: <input type="text" value="A"/> <input type="text" value="B"/> <input type="text" value="Number_10"/>

No.	Content	Format
331	Safety factor	Response: <input type="text" value="A,B _ 1 .x"/> x = 0 ... 9 Write: <input type="text" value="A,W 3,3,1 _ 1 .x"/> x = 0 ... 9
332_001 ... 332_999	COUNTING application: Reference piece weight memory 1 ... 999 PIECE-FILLING application: Target memory 1 ... 999	Response: COUNTING and NEUTRAL MEASUREMENT <input type="text" value="A,B _ Name (text_20) _ _ "/> <input type="text" value="Piece weight (weight value) _ Unit _ _ "/> PIECE-FILLING <input type="text" value="A,B _ Name (text_20) _ _ "/> <input type="text" value="Piece weight (weight value) _ Unit _ _ "/> <input type="text" value="Target quantity (number_10) _ Unit _ _ "/> <input type="text" value="Limit 1 (number_10) _ Unit _ _ "/> <input type="text" value="Limit 2 (number_10) _ Unit _ _ "/> <input type="text" value="Tolerance(-) (number_10) _ Unit _ _ "/> <input type="text" value="Tolerance(+) (number_10) _ Unit _ _ "/> Write: COUNTING and NEUTRAL MEASUREMENT <input type="text" value="A,W 3,x,x _ Name (text_20) _ _ \$,\$ _ _ "/> <input type="text" value="Piece weight (weight value) _ Unit _ _ "/> PIECE-FILLING <input type="text" value="A,W 3,x,x _ Name (text_20) _ _ \$,\$ _ _ "/> <input type="text" value="Piece weight (weight value) _ Unit _ _ \$,\$ _ _ "/> <input type="text" value="Target quantity (number_10) _ Unit _ _ \$,\$ _ _ "/> <input type="text" value="Limit 1 (number_10) _ Unit _ _ \$,\$ _ _ "/> <input type="text" value="Limit 2 (number_10) _ Unit _ _ \$,\$ _ _ "/> <input type="text" value="Tolerance(-) (number_10) _ Unit _ _ \$,\$ _ _ "/> <input type="text" value="Tolerance(+) (number_10) _ Unit _ _ \$,\$ _ _ "/> Comment: xx = 32_001 ... 32_999 Unit = PCS
332 ... 356	COUNTING: Reference piece weight memory 1 ... 25 PIECE-FILLING: Target memory 1 ... 25	Response: as for 332_001 ... 332_999 Write: as for 332_001 ... 332_999 Note: xx = 32 ... 56 The contents of the target memory 1 ... 25 are identical to the contents of the target memory 332_001 ... 332_025. Unit = PCS
357	Format	Response: <input type="text" value="A,B _ Number (right-justified) _ _ "/> Write: <input type="text" value="A,W 3,5,7 _ _ Number (right-justified) _ _ "/> Comment: only for the NEUTRAL MEASUREMENT application Data format number: 0; 0.0; 0.00; 0.000
358	Preferred reference weighing platform	Response: <input type="text" value="A,B _ n _ _ "/> Write: <input type="text" value="A,W 3,5,8 _ _ n _ _ "/> Comment: n = 1 ... 3, integral
359	Best reference weighing platform	Response: <input type="text" value="A,B _ n _ _ "/> Comment: n = 1 ... 3, integral
360	Stop value item counter	Response: <input type="text" value="A,B _ _ Number_4 _ _ "/> Write: <input type="text" value="A,W 3,6,0 _ _ Number_4 _ _ "/>

No.	Content	Format																																								
361	Current quantity without unit	Response: <input type="text" value="A,B _ Number_10"/>																																								
362	Sum tare weight	Response: <input type="text" value="A,B _ Weight value _ Unit"/>																																								
363 ... 387 45	Text memory 21 ... 45	Response: <input type="text" value="A,B _ Text_20"/> Write: <input type="text" value="A,W 3,x,x _ Text_20"/> Comment: xx = 63 ... 87 The contents of the text memory 21 ... 45 are identical to the contents of the target read-only memory 071_021 ... 071_045.																																								
388	Correction factor	Response: <input type="text" value="A,B _ Factor"/> Write: <input type="text" value="A,W 3,8,8 _ Factor"/> Comment: Factor: 0.10 ... 10.00; step size 0.01																																								
389	Denomination of the physical variable	Response: <input type="text" value="A,B _ Text_10"/> Write: <input type="text" value="A,W 3,8,9 _ Text_10"/> Comment: only for the NEUTRAL MEASUREMENT application																																								
390	Factor for refilling correction	Response: <input type="text" value="A,B _ Factor"/> Write: <input type="text" value="A,W 3,9,0 _ Factor"/> Comment: Factor: 0.0 ... 0.9; step size 0.1																																								
391	Filling status for PIECE-FILLING application	Response: <input type="text" value="A,B _ Code (number_3)"/> , e. g.: <table border="0"> <thead> <tr> <th>Code</th> <th>Meaning</th> </tr> </thead> <tbody> <tr><td>000</td><td>Switch-on or basic state</td></tr> <tr><td>010</td><td>Ready for dispensing (filling parameters loaded)</td></tr> <tr><td>011</td><td>Display SUM after pressing the SUM key</td></tr> <tr><td>015, 016</td><td>Taring process running (triggered with external key)</td></tr> <tr><td>021, 022</td><td>Fine feed off due to/after overloading or underloading</td></tr> <tr><td>030</td><td>Taring process running (with automatic tare)</td></tr> <tr><td>040</td><td>Coarse feed on</td></tr> <tr><td>041, 042</td><td>Coarse feed off with external STOP key</td></tr> <tr><td>045, 046</td><td>Coarse feed off with/after overloading or underloading</td></tr> <tr><td>050</td><td>Fine feed on</td></tr> <tr><td>051, 052</td><td>Fine feed off with external STOP key</td></tr> <tr><td>055, 056</td><td>Fine feed off due to overloading or underloading</td></tr> <tr><td>070</td><td>Filling ended: Wait for stability</td></tr> <tr><td>071, 072</td><td>Filling ended with external STOP key</td></tr> <tr><td>073, 074</td><td>Refilling: During the pulse pause fine feed on with external STOP key</td></tr> <tr><td>075</td><td>Refilling: During the pulse duration fine feed on</td></tr> <tr><td>076</td><td>Refilling: During the pulse pause fine feed off</td></tr> <tr><td>077, 078</td><td>Refilling: During the pulse duration Fine feed off with external STOP key</td></tr> <tr><td>083</td><td>Filling ended: Display OKAY</td></tr> </tbody> </table> <p>See next page.</p>	Code	Meaning	000	Switch-on or basic state	010	Ready for dispensing (filling parameters loaded)	011	Display SUM after pressing the SUM key	015, 016	Taring process running (triggered with external key)	021, 022	Fine feed off due to/after overloading or underloading	030	Taring process running (with automatic tare)	040	Coarse feed on	041, 042	Coarse feed off with external STOP key	045, 046	Coarse feed off with/after overloading or underloading	050	Fine feed on	051, 052	Fine feed off with external STOP key	055, 056	Fine feed off due to overloading or underloading	070	Filling ended: Wait for stability	071, 072	Filling ended with external STOP key	073, 074	Refilling: During the pulse pause fine feed on with external STOP key	075	Refilling: During the pulse duration fine feed on	076	Refilling: During the pulse pause fine feed off	077, 078	Refilling: During the pulse duration Fine feed off with external STOP key	083	Filling ended: Display OKAY
Code	Meaning																																									
000	Switch-on or basic state																																									
010	Ready for dispensing (filling parameters loaded)																																									
011	Display SUM after pressing the SUM key																																									
015, 016	Taring process running (triggered with external key)																																									
021, 022	Fine feed off due to/after overloading or underloading																																									
030	Taring process running (with automatic tare)																																									
040	Coarse feed on																																									
041, 042	Coarse feed off with external STOP key																																									
045, 046	Coarse feed off with/after overloading or underloading																																									
050	Fine feed on																																									
051, 052	Fine feed off with external STOP key																																									
055, 056	Fine feed off due to overloading or underloading																																									
070	Filling ended: Wait for stability																																									
071, 072	Filling ended with external STOP key																																									
073, 074	Refilling: During the pulse pause fine feed on with external STOP key																																									
075	Refilling: During the pulse duration fine feed on																																									
076	Refilling: During the pulse pause fine feed off																																									
077, 078	Refilling: During the pulse duration Fine feed off with external STOP key																																									
083	Filling ended: Display OKAY																																									

No.	Content	Format
391	Filling status for the PIECE-FILLING application	Response: <input type="text" value="A"/> <input type="text" value="B"/> <input type="text" value="Code (number_3)"/> , e. g.: <b>Code      Meaning</b> 086      Filling ended: Display SURPLUS 087      Output sum following sum overflow or after the stop value of the item counter is reached 100      After end of filling: Total 101      After end of filling: Wait for movement 102      After end of filling: Wait for new start 110      Filling ended: Display DEFICIT 112, 113 Filling cancelled with STOP key 114      After incorrect filling: Display CORRECT 116      After incorrect filling: Display CONFIRM 235, 236 Learn mode: Fine feed off due to/after overloading or underloading 241      Learn mode: Coarse feed off, wait for stabilization 242, 243 Learn mode: Coarse feed off with external STOP key 245      Learn mode: Fine feed on 246, 247 Learn mode: Fine feed off with external STOP key 248      Learn mode: Fine feed off, wait for stabilization 249, 250 Learn mode: Interruption with external STOP key
392	Mean value $\bar{x}$ for piece weight of samples (statistics)	Response: <input type="text" value="A"/> <input type="text" value="B"/> <input type="text" value="Weight value"/> <input type="text" value="Unit"/>
393	Standard deviation $s$ for piece weight of samples (statistics)	Response: <input type="text" value="A"/> <input type="text" value="B"/> <input type="text" value="Weight value"/> <input type="text" value="Unit"/>
394	Minimum $\min$ for piece weight of samples (statistics)	Response: <input type="text" value="A"/> <input type="text" value="B"/> <input type="text" value="Weight value"/> <input type="text" value="Unit"/>
395	Maximum $\max$ for piece weight of samples (statistics)	Response: <input type="text" value="A"/> <input type="text" value="B"/> <input type="text" value="Weight value"/> <input type="text" value="Unit"/>
396	Number $n$ of samples (statistics)	Response: <input type="text" value="A"/> <input type="text" value="B"/> <input type="text" value="Number_4"/>
397	Piece weight of current sample (statistics)	Response: <input type="text" value="A"/> <input type="text" value="B"/> <input type="text" value="Weight value"/> <input type="text" value="Unit"/>
398	Barcode EAN 25	Response: <input type="text" value="A"/> <input type="text" value="B"/> <input type="text" value="2"/> <input type="text" value="5"/> <input type="text" value="Article"/> <input type="text" value="Check digit"/> <input type="text" value="Quantity"/> Comment: Article:      4-digit article no. from memory Code A Check digit: 1-digit no., calculated by ID7-Count Quantity:      5-digit



No.	Content	Format																													
399	Barcode EAN 26, EAN 128 - 30	<p>Response: <table border="1" style="display: inline-table; vertical-align: middle;"><tr><td>A</td><td>B</td><td> </td><td>EAN 26</td><td> </td><td> </td><td>EAN 128-30</td></tr></table></p> <p>EAN 26: <table border="1" style="display: inline-table; vertical-align: middle;"><tr><td>2</td><td>6</td><td>Article</td><td>Check digit</td><td>Pieces</td></tr></table></p> <p>Article: 4-digit Article No. from memory Code A  Check digit: 1-digit, calculated by ID7-Count for the weight  Pieces: 5-digit</p> <p>EAN 128-30: <table border="1" style="display: inline-table; vertical-align: middle;"><tr><td>0</td><td>1</td><td>9</td><td>Article</td><td>Check digit</td><td>3</td><td>0</td><td>Pieces</td><td>x</td></tr></table> or</p> <p><table border="1" style="display: inline-table; vertical-align: middle;"><tr><td>0</td><td>1</td><td>9</td><td>Article</td><td>3</td><td>0</td><td>Pieces</td><td>x</td></tr></table></p> <p>Article: Article No. from memory Code A  max. 12 or 13 digits  Check digit: 1-digit, calculated by ID7-Count  Pieces: x-digit pieces from Block 310  x: 0, 2, 4, 6, 8: Number of places for pieces  0: lowest possible even number of places</p>	A	B		EAN 26			EAN 128-30	2	6	Article	Check digit	Pieces	0	1	9	Article	Check digit	3	0	Pieces	x	0	1	9	Article	3	0	Pieces	x
A	B		EAN 26			EAN 128-30																									
2	6	Article	Check digit	Pieces																											
0	1	9	Article	Check digit	3	0	Pieces	x																							
0	1	9	Article	3	0	Pieces	x																								

## 5 What to do if ...?

Error / Display	Possible causes	Remedy
REF. WEIGHT TOO LOW	<ul style="list-style-type: none"> <li>Reference weight below counting limit weight, i.e. below 10 % of minimum reference weight</li> </ul>	<ul style="list-style-type: none"> <li>→ Increase reference weight with larger reference quantity</li> <li>→ If present, use more precise weighing platform</li> </ul>
ADD ... ITEMS	<ul style="list-style-type: none"> <li>Reference weight is below minimum weight specific to weighing platform</li> </ul>	<ul style="list-style-type: none"> <li>→ Increase reference quantity by specified quantity and confirm with ENTER</li> <li>→ Ignore warning by pressing keys for fixed or variable reference quantity</li> </ul>
LOAD SCALE	<ul style="list-style-type: none"> <li>During totalizing there is no weight on the weighing platform</li> <li>During totalizing the same, already totalized weight is on the weighing platform</li> </ul>	<ul style="list-style-type: none"> <li>→ Lay weighing/counting sample on weighing platform</li> <li>→ Change weighing/counting sample</li> </ul>
OVERFLOW PIECES	<ul style="list-style-type: none"> <li>Capacity of quantity display exceeded</li> </ul>	<ul style="list-style-type: none"> <li>→ Relieve weighing platform and divide counting sample into sub-quantities</li> </ul>
OVERFLOW SUM GROSS OVERFLOW SUM NET	<ul style="list-style-type: none"> <li>Capacity of buffer for sum weight exceeded</li> </ul>	<ul style="list-style-type: none"> <li>→ Delete sum</li> </ul>
OVERFLOW ITEMCOUNTER	<ul style="list-style-type: none"> <li>Itemcounter has reached stop value</li> </ul>	<ul style="list-style-type: none"> <li>→ Delete itemcounter</li> <li>→ Check start value and stop value of itemcounter if necessary</li> </ul>
WRONG SCALE	<ul style="list-style-type: none"> <li>Invalid scale number entered</li> </ul>	<ul style="list-style-type: none"> <li>→ Enter scale number for an installed weighing scale</li> </ul>
WRONG SAMPLE	<ul style="list-style-type: none"> <li>Sample too large or too small for statistics</li> </ul>	<ul style="list-style-type: none"> <li>→ Place right sample on weighing platform</li> </ul>
INPUTS/OUTPUTS MISSING	<ul style="list-style-type: none"> <li>No inputs/outputs available on ID7-Count</li> </ul>	<ul style="list-style-type: none"> <li>→ Configure inputs/outputs</li> </ul>
WRONG CODE	<ul style="list-style-type: none"> <li>Wrong password entered</li> </ul>	<ul style="list-style-type: none"> <li>→ Enter right password</li> </ul>
Display shows running value without unit	<ul style="list-style-type: none"> <li>NEUTRAL MEASUREMENT activated and no unit defined</li> </ul>	<ul style="list-style-type: none"> <li>→ Enter unit for NEUTRAL MEASUREMENT application</li> </ul>

## 6 Technical data

Counting functions	
Quantity	Continuously running display, 7-place (up to 9 999 999 pieces)
Piece weight determination	Either from standard reference pieces or variable reference pieces (1 ... 9 999 pieces)
Piece weight entry	Entry of up to 8 places including decimal point in various weight units
Piece weight memory	<ul style="list-style-type: none"> <li>• 999 memories for frequently used counting parts, protected against power failure</li> <li>• With 20-place alphanumeric article designation</li> <li>• With 20-place alphanumeric article number</li> </ul>
Target memory	<ul style="list-style-type: none"> <li>• 999 memories for frequently used target values, protected against power failure</li> <li>• With 20-place alphanumeric identification</li> <li>• With 20-place alphanumeric article number</li> <li>• Only in PIECE-FILLING application</li> </ul>
Minimum reference monitoring	Dependent on the connected weighing platform
Multi-scale systems	Preferred reference scale freely selectable
Neutral measurement	For simple determination of weight-dependent variables, e. g. lengths, areas, volumes
Totalizing	<ul style="list-style-type: none"> <li>• In weighing mode: gross sum, net sum</li> <li>• For piece counting: gross sum, net sum, piece sum</li> </ul>
Sum memory	Up to 8 places including decimal point
Item counter	Up to 9 999, start and stop value freely selectable

# 7 Appendix

## 7.1 Connection diagram and terminal assignment for 8-ID7 relay box

For the PIECE-FILLING application the ID7-Count requires the RS485-ID7 serial interface and the 8-ID7 relay box:

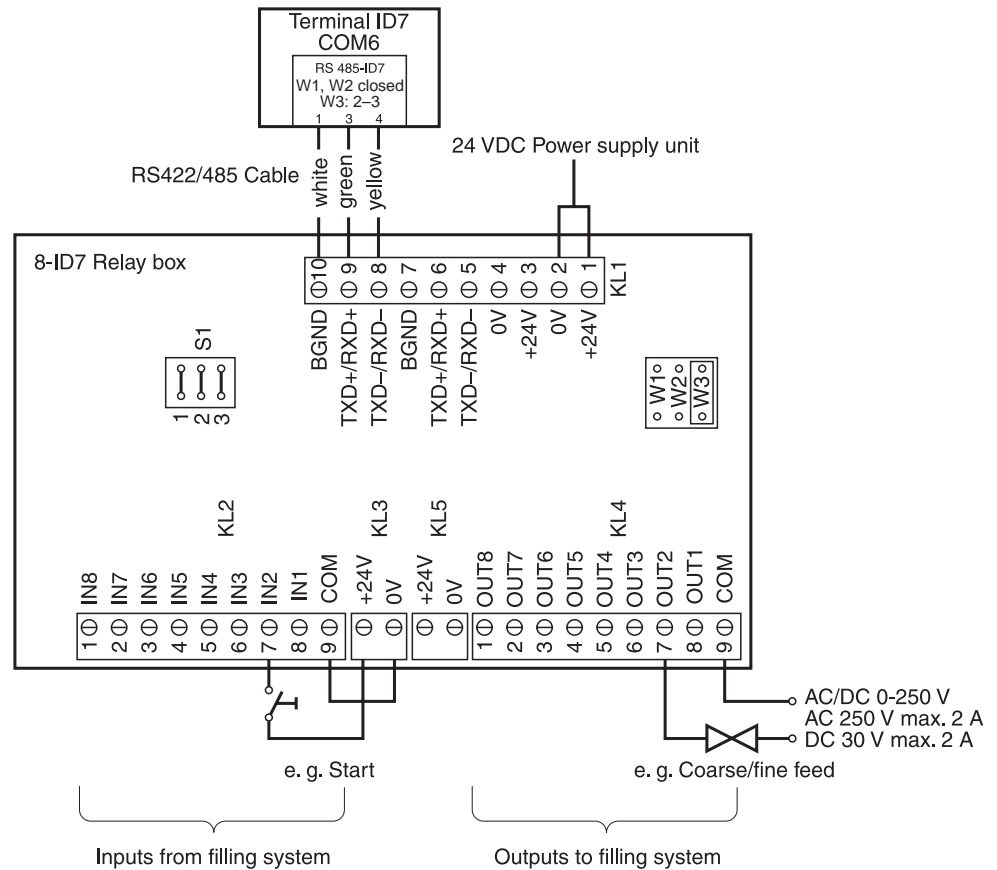

KL2	Assignment	Relay box: Inputs from filling system	KL4	Assignment	Relay box: Outputs to filling system
8	IN1	Not assigned	8	OUT1	On/off
7	IN2 *	Start (PLC)	7	OUT2	Coarse/fine feed
6	IN3	Stop (PLC)	6	OUT3	Not assigned
5	IN4 *	Confirm	5	OUT4	Underfilled
4	IN5	Tare	4	OUT5	Acceptable
3	IN6	Not assigned	3	OUT6	End of filling
2	IN7	Not assigned	2	OUT7	Overfilled
1	IN8	Not assigned	1	OUT8	Ready

\* IN2 and IN4 can be connected and operated with a key.

### Notes

- The 8-ID7 relay box corresponds to the Binary Interface Unit (BIU). For additional information see the operating instructions and installation information for the Binary Interface Unit 505981.
- The 8-ID7 relay box can also be replaced with 4I/O-ID7 interfaces and 4-ID7 relay boxes.

1. Relay box 4-ID7 on COM6	IN1 ... IN4	Terminal 2, IN0 ... IN3
	OUT1 ... OUT4	Terminal 3, OUT0 ... OUT3
2. Relay box 4-ID7 on COM5	IN5 ... IN8	Terminal 2, IN4 ... IN7
	OUT5 ... OUT8	Terminal 3, OUT4 ... OUT7

## 7.2 Connection suggestions for various vibration conveyors

### Neutral connection

Control of a conveyor system with separate coarse feed and fine feed circuits:

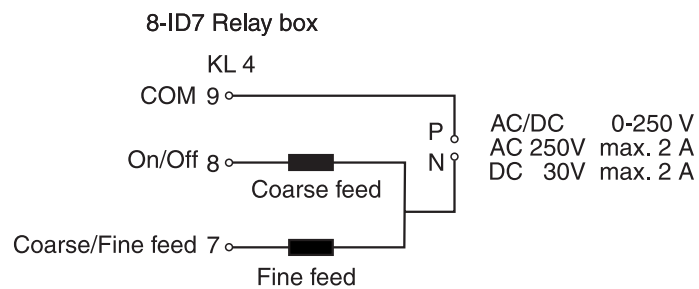

### External control unit (PLC)

HSTD-10 control unit from Gericke:

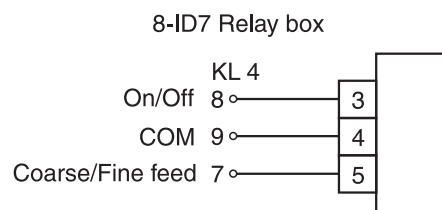

## 8 Index

### A

Add mode 19, 28  
Article number 6, 12, 17,  
29, 34  
Auto totalize 30  
Automatic tare 10, 30

### C

Coarse feed 10  
Correction factor 28  
Counting 5, 25  
Counting functions 41

### D

DeltaTrac 21  
Documentation 2

### E

Error messages 40

### F

Fine feed 10  
Function keys 5, 9, 16

### I

Installation 2  
Item counter 27

### L

Learn mode 11, 30

### M

Min Ref Weight 27  
Minimum reference  
weight 19

### N

Neutral measurement 16, 25

### P

Piece-filling 9, 14, 25  
Preferred reference weighing  
platform 22, 28

### R

Recall information 23  
Redispensing 10  
Redispensing correction 11,  
30  
Reference determination 6  
Reference optimization 19,  
27  
Reference piece weight 5, 9  
Reference weight 16, 19, 25  
Reference weight memory 25

Refilling 31  
Reset Pac 29

### S

Safety precautions 2  
Specify reference value 6,  
12, 16  
Statistics 20

### T

Target memory 26  
Technical data 41  
Totalizing 8, 15, 18

### W

What to do if ...? 40





**22004132E**

Subject to technical changes © Mettler-Toledo (Albstadt) GmbH 04/10 Printed in Germany 22004132E

**Mettler-Toledo (Albstadt) GmbH**

D-72458 Albstadt

Tel. ++49-7431-14 0, Fax ++49-7431-14 232

Internet: <http://www.mt.com>