

**Operating instructions**  
**Bedienungsanleitung**  
**Mode d'emploi**  
**Instrucciones de manejo**  
**Istruzioni per l'uso**  
**Gebruiksaanwijzing**

**METTLER TOLEDO**

**Paint Scale PS7, PS7-X**  
**Farbmischwaage PS7, PS7-X**  
**Balance pour le mélange des couleurs PS7, PS7-X**  
**Balanza para mezcla de colores PS7, PS7-X**  
**Bilancia per vernici PS7, PS7-X**  
**Verfmengweegschaal PS7, PS7-X**

Page 5

Seite 29

Page 53

Página 77

Pagina 101

Pagina 125

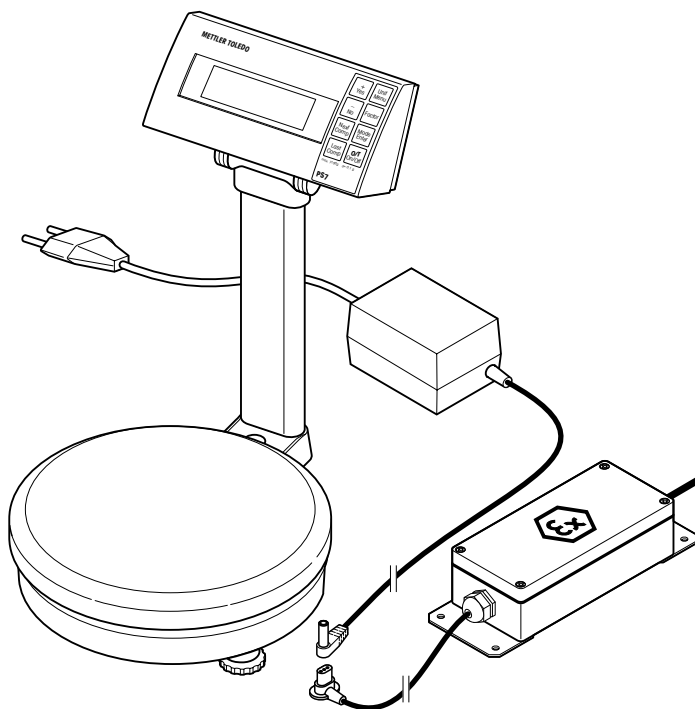

English

Deutsch

Français

Español

Italiano

Nederlands

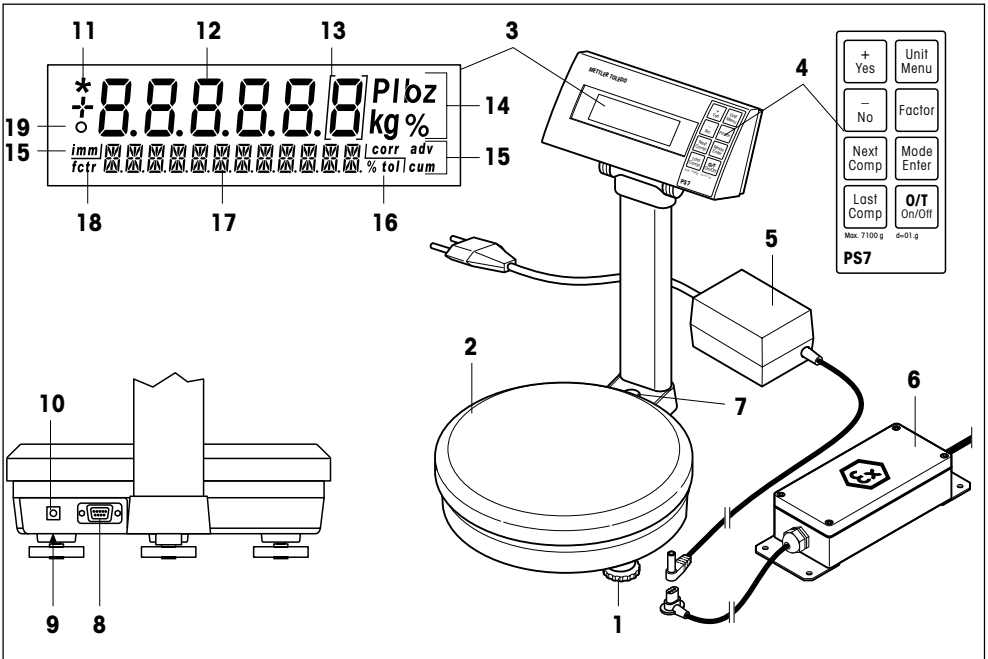

## English

- 1 Leveling feet (on certified scales only)
- 2 Weighing pan
- 3 Display
- 4 Function keys  
(for key functions, see Section 3)
- 5 AC adapter (PS7)
- 6 Power supply unit (PS7-X)
- 7 Level indicator (on certified scales only)
- 8 Dual RS232C interface
- 9 Connecting socket for AC adapter/  
power supply unit
- 10 Grounding screw (PS7-X only)
- 11 Symbol for calculated weight value
- 12 Primary display
- 13 Certification brackets  
(only on certified scales with  $e=10d$ )
- 14 Weighing units
- 15 Formula weighing symbol
- 16 Tolerance
- 17 Auxiliary display
- 18 Factor
- 19 Stability detector

## Deutsch

- 1 Stellfüsse (nur bei geeichten Waagen)
- 2 Waagschale
- 3 Anzeige
- 4 Funktionstasten  
(Tastenfunktionen siehe Kapitel 3)
- 5 Netzadapter (PS7)
- 6 Speisegerät (PS7-X)
- 7 Libelle (nur bei geeichten Waagen)
- 8 Doppelt belegte Schnittstelle RS232C
- 9 Anschlussbuchse Netzadapter/Speisegerät
- 10 Erdungsschraube (nur PS7-X)
- 11 Symbol für berechneten Gewichtswert
- 12 Primäranzeige
- 13 Eichklammern  
(nur bei geeichten Waagen mit  $e=10d$ )
- 14 Wä geeinheiten
- 15 Rezeptiersymbole
- 16 Toleranz
- 17 Sekundäranzeige
- 18 Faktor
- 19 Stillstandskontrolle

## Français

- 1 Pieds réglables (uniquement sur balances vérifiées)
- 2 Plateau
- 3 Afficheur
- 4 Touches de fonction  
(fonctions des touches, voir chapitre 3)
- 5 Adaptateur secteur (PS7)
- 6 Unité d'alimentation (PS7-X)
- 7 Niveau à bulle (uniquement sur balances vérifiées)
- 8 Interface RS232C à double affectation
- 9 Prise adaptateur secteur/unité d'alimentation
- 10 Vis de mise à la terre (uniquement PS7-X)
- 11 Symbole pour valeur pondérale calculée
- 12 Afficheur primaire
- 13 Parenthèses  
(uniquement sur balances vérifiées avec  $e=10d$ )
- 14 Unités de pesage
- 15 Symboles de formulation
- 16 Tolérance
- 17 Afficheur secondaire
- 18 Facteur
- 19 Détecteur de stabilité

## Italiano

- 1 Piedini regolabili (solo per bilance omologate)
- 2 Piatto della bilancia
- 3 Display
- 4 Tasti funzione  
(Tasti funzione vedi capitolo 3)
- 5 Adattatore di rete (PS7)
- 6 Alimentatore (PS7-X)
- 7 Livella (solo per bilance omologate)
- 8 Interfaccia a doppia assegnazione RS232C
- 9 Presa per adattatore/alimentatore
- 10 Vite di messa a terra (solo per PS7-X)
- 11 Simbolo per il peso calcolato
- 12 Display primario
- 13 Parentesi di taratura  
(solo per bilance omologate con  $e=10d$ )
- 14 Unità di misura
- 15 Simbolo per ricette
- 16 Tolleranza
- 17 Display secondario
- 18 Fattore
- 19 Rilevatore automatico di stabilità

## Español

- 1 Patas regulables (sólo balanzas verificadas)
- 2 Platillo
- 3 Pantalla
- 4 Teclas de función  
(Teclas de función, ver capítulo 3)
- 5 Adaptador de red (PS7)
- 6 Fuente de alimentación (PS7-X)
- 7 Nivel de burbuja (sólo en bal. verificadas)
- 8 Interface de doble conexión RS232C
- 9 Toma de adaptador de red/fuente de alimentación
- 10 Tornillo de tierra (sólo PS7-X)
- 11 Símbolo del valor de peso calculado
- 12 Indicador primario
- 13 Paréntesis  
(sólo en balanzas verificadas con  $e=10d$ )
- 14 Unidades de pesada
- 15 Símbolos de formulación
- 16 Tolerancia
- 17 Indicador secundario
- 18 Factor
- 19 Control de estabilidad

## Nederlands

- 1 Stelvoeten (alleen bij geijkte weegschalen)
- 2 Weegplateau
- 3 Display
- 4 Functietoetsen  
(voor toetsfuncties zie Hoofdstuk 3)
- 5 Netadapter (PS7)
- 6 Voeding (PS7-X)
- 7 Waterpas (alleen bij geijkte weegschalen)
- 8 Dubbel toegewezen interface RS232C
- 9 Aansluitbus netadapter/voeding
- 10 Aardingsschroef (alleen PS7-X)
- 11 Symbool voor berekende gewichtswaarde
- 12 Eerste display
- 13 IJkmarkeringen  
(alleen bij geijkte weegschalen met  $e=10d$ )
- 14 Weegeenheden
- 15 Recepteursymbolen
- 16 Tolerantie
- 17 Tweede display
- 18 Factor
- 19 Stilstandscontrole

## Contents

1	Introduction .....	5
2	Preparing the scale for use .....	6
3	Key functions .....	7
4	Weighing .....	8
5	Formula weighing .....	9
6	Master mode .....	22
7	Error messages .....	24
8	Interfaces / accessories .....	25
9	Technical data / guidelines and test standards .....	26

## Inhalt

1	Einleitung .....	29
2	Inbetriebnahme .....	30
3	Tastenfunktionen .....	31
4	Wägen .....	32
5	Rezeptieren .....	33
6	Der Mastermode .....	46
7	Fehlermeldungen .....	48
8	Schnittstellen / Zubehör .....	49
9	Technische Daten / Richtlinien und Prüfnormen .....	50

## Table des matières

1	Introduction .....	53
2	Mise en service .....	54
3	Fonctions des touches .....	55
4	Pesage .....	56
5	Formulation .....	57
6	Le Master Mode .....	70
7	Messages d'erreur .....	72
8	Interfaces / Accessoires .....	73
9	Caractéristiques techniques / Directives et normes d'essai .....	74

## Indice

1	Introducción .....	77
2	Puesta en marcha .....	78
3	Funciones de teclas .....	79
4	Pesaje .....	80
5	Formulación .....	81
6	Master Mode .....	94
7	Mensajes de error .....	96
8	Interfaces/ Accesorios .....	97
9	Datos técnicos / Directrices y normas de comprobación .....	98

## Indice

1	Introduzione .....	101
2	Messa in funzione .....	102
3	Tasti funzione .....	103
4	Pesare .....	104
5	Esecuzione della ricetta .....	105
6	La modalità Master .....	118
7	Messaggi di errore .....	120
8	Interfacce/Accessori .....	121
9	Dati tecnici / Direttive e norme .....	122

## Inhoud

1	Inleiding .....	125
2	Ingebruikname .....	126
3	Toetsfuncties .....	127
4	Wegen .....	128
5	Recepteren .....	129
6	De Mastermode .....	142
7	Foutmeldingen .....	144
8	Interfaces /Toebehoren .....	145
9	Technische gegevens / Richtlijnen en testnormen .....	146

# 1 Introduction

## 1.1 General

Thank you for purchasing the **PS7 paint scale or the intrinsically safe PS7-X version**. The PS7/PS7-X makes it possible to mix components in predefined proportions by weighing. The scale has a number of correction modes to compensate for errors made while weighing the components. A built-in RS232 interface allows the scale to be connected to a printer, a computer, or an auxiliary display.

Please read through this manual carefully and always follow the instructions!

## 1.2 Safety and environment



- **Do not use the PS7 scale in hazardous environments** where there are explosive mixtures of gases, vapors, or dusts.

In **hazardous areas**, a type **PS7-X** scale must be used. The **certified METTLER TOLEDO power supply unit** must always be used for connecting the scale. The operating instructions for the power supply unit must always be observed and followed. Because of the danger of electrostatic charge, it is only permitted to use a protective cover in hazardous areas if the cover is made from statically non-hazardous material.

- To connect the scale to the power supply, use **only the AC adapter (PS7) or power supply unit (PS7-X) supplied with the scale**. Make sure the voltage printed on the adapter or supply unit is the same as the local power supply voltage. Check the cable of the AC adapter/power supply unit regularly. If the cable or the AC adapter/power supply unit is damaged, the scale must not be used.
- Use only recommended accessories and peripherals.
- Treat the scale carefully, it is a precision instrument. Knocks to the weighing pan, or overloading it excessively, damage the scale.
- **Before starting to clean the scale, disconnect it from the power supply!**

Cleaning: Use a moist cloth (no acids, alkalis, or solvents). If the scale is heavily soiled, remove weighing pan protective cover (if present) and the leveling feet (certified scales only), and clean these parts separately. Observe company- and industry-specific regulations regarding cleaning intervals and permitted cleaning agents.
- When disposing of the scale, observe the applicable environmental regulations.

## 1.3 Notes regarding certified models

On certified models the following functions are deactivated:

- Formula weighing (factor weighing and formula weighing with correction)
- Changing the weighing unit (on certified scales the weighing unit is set to "g" as standard)
- Calibration (certified models must be adjusted/calibrated by an authorized METTLER TOLEDO service representative)

## 2 Preparing the scale for use

### 2.1 Setting up and leveling

For accurate weighing results, care must be taken to select the optimal location for the scale!



Place the scale on a stable surface which is free of vibrations and as horizontal as possible.

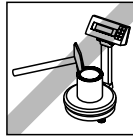

Never use a hammer to close paint cans on the weighing pan.



Avoid excessively fluctuating temperatures and direct sunlight. Ensure correct environmental conditions.

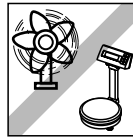

Avoid drafts (for example, from fans or air conditioning).

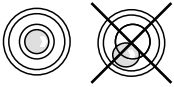

**Certified scales only:** Adjust the leveling feet until the scale is absolutely horizontal. The air bubble must lie within the inner circle.

Note: Certified scales must be adjusted at the workplace by an authorized METTLER TOLEDO service representative.

#### Major changes of geographical location

It is advisable to calibrate the scale before using it for the first time (see Section 6.3). Certified scales must be certified on site according to the local national certification regulations.

### 2.2 Connecting to the power supply

**PS7-X for hazardous zones (areas):** Type PS7-X scales for hazardous zones (areas) may only be connected to a certified power supply unit. To do so, always observe and follow the separate installation instructions for the power supply unit.

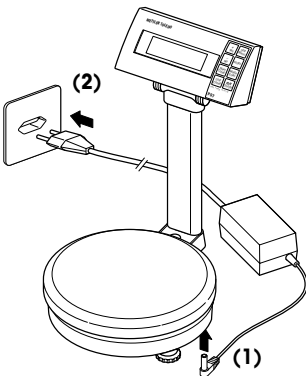









**Note:** Before connecting the AC adapter, check that the voltage printed on the adapter is the same as the local power supply voltage.

**Note:** First connect the AC adapter to the socket on the underside of the scale (1). Only insert the plug of the AC adapter into the power supply outlet after you have done this (2).

When the scale has been connected, it performs a display test in which all the segments and then the software version are briefly displayed. As soon as the zero display appears, the scale is ready for operation.

### 3 Key functions

Key	Function	
	Press briefly	Press and hold down
	Tare scale **	Switch scale on and off **
	Select conversion factor for weighing a smaller or larger quantity of a formula	Reset the conversion factor to "1" (weighing without factor)
	Change the weighing unit	Enter Master Mode ** (see Section 6.1)
	Confirm the target weight of a weighed component and continue with the next component	—
	Confirm the target weight of the last component of a formula that was weighed	Abort formula weighing operation
	Select formula weighing method or tolerance  <b>Advanced formula weighing mode</b> Set next digit of target weight	Confirm selected formula weighing method or confirm selected tolerance  <b>Advanced formula weighing mode</b> Confirm target weight entered
	Function depends on the currently selected operating mode  <b>Master mode **</b> Confirm the current setting  <b>Standard formula weighing mode</b> Increase target value of component  <b>Advanced formula weighing mode</b> Increase target value of component	<b>Master mode</b> —  <b>Standard formula weighing mode</b> Increase target value of component by 1.0  <b>Advanced formula weighing mode</b> —
	Function depends on the currently selected operating mode  <b>Master mode **</b> Reject the current setting  <b>Standard formula weighing mode</b> Reduce the target value of the component  <b>Advanced formula weighing mode</b> Reduce the target value of the component	<b>Master mode</b> —  <b>Standard formula weighing mode</b> Reduce the target value of the component by 1.0 (if the key is held down, the value is automatically reduced further)  <b>Advanced formula weighing mode</b> Return to last digit

\*\* On certified scales only these keys are active

## 4 Weighing

### 4.1 Switching on/off and selecting the weighing unit

#### Switching on/off



To switch the scale on or off, press the «**O/T**» key and **hold it down**.

After the scale has been switched on, the scale performs a display test. As soon as the weight display appears, the scale is ready for weighing and automatically set to zero.

#### Select weighing unit (not available on certified scales)



By **briefly pressing the «Unit»** key, the weighing unit can be switched over between "g" (gram), "oz" (ounce), and "P" (part).

### 4.2 Simple weighing

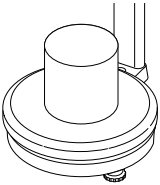

Place the weighing container on the scale. Press the «**O/T**» key briefly to tare. The zero display appears.

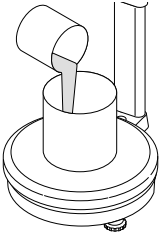

Pour in the desired quantity of the substance to be weighed.

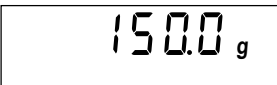

Wait until the stability detector (ring symbol in the display) goes off, and then read the weighing result.



## 5 Formula weighing

Note: **On certified scales the formula weighing functions are deactivated** (factor weighing, formula weighing with correction).

### 5.1 Select factor

To weigh a larger or smaller quantity of a given formula, a factor (multiplier) can be selected.

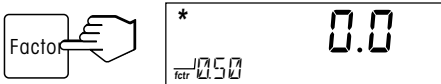

To activate factor weighing, **briefly press** the «Factor» key. The factor used for the last factor weighing (e.g. 0.50) appears in the lower left corner of the display.

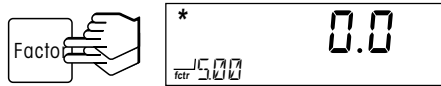

Now press the «Factor» key **briefly several times** until the desired factor (0.20 ... 5.00) is displayed.

In the subsequent weighing, a component is weighed to its target weight (e.g. 1000 g) according to the formula. However, depending on the factor selected, the actual quantity weighed is greater or smaller by the factor.

**Example 1:** Weight according to formula 1000 g, factor selected 0.50 (for half quantity). Display: 1000; actually weighed: 500 g.

**Example 2:** Weight according to formula 1000 g, factor selected 3.00 (for triple quantity). Display: 1000; actually weighed: 3000 g.



**To deactivate factor weighing:** Press the «Factor» key and **hold it down**.

The factor display disappears and the factor is reset to 1.

## 5.2 The various methods of formula weighing

The PS7 provides several methods of formula weighing. Each method of formula weighing comprises:

- A **formula weighing mode**:
  - **“ST” standard formula weighing**: In this mode the desired quantity of a component is weighed and confirmed. If an incorrect quantity is dispensed, before the next component is weighed, the actual target weight of the incorrectly weighed component must be entered. The error is automatically taken into account when subsequent components are weighed.
  - **“ADV” advanced formula weighing**: In this mode the target weight of a component is first entered. The component is then weighed and confirmed. Any error in the weighing is automatically taken into account when subsequent components are weighed.
- A **display type**:
  - **“ABS” absolute display**: displays the absolute weight of a component.
  - **“CUM” cumulative display**: displays the cumulative weight.
- A **correction mode**:
  - **“IMM” correction**: correction immediately after each incorrectly weighed component.
  - **“END” correction**: correction at the end of the formula weighing operation.

Combinations of these result in **8 different formula weighing methods**:

Formula weighing method (see respective section)	Formula weighing mode		Display type		Correction mode	
	Standard	Advanced	Absolute	Cumulative	Immediate	At end
ST ABS END → 5.5	X		X			X
ST CUM END → 5.5	X			X		X
ST ABS IMM → 5.6	X		X		X	
ST CUM IMM → 5.6	X			X	X	
ADV ABS END → 5.7		X	X			X
ADV CUM END → 5.7		X		X		X
ADV ABS IMM → 5.8		X	X		X	
ADV CUM IMM → 5.8		X		X	X	

### 5.3 Select formula weighing method



Corr P  
STD ABS END

Press the **«Mode» key briefly**. The formula weighing method which was last pressed appears in the display (factory setting: "STD ABS END").



Corr P  
ADV ABS END

Press the **«Mode» key briefly** several times to select the desired formula weighing method (e.g. "ADV ABS END").



tol P  
1.5% tol adv

Confirm the selected formula weighing method by pressing the **«Mode» key and holding it down**.

If you select an advanced formula weighing method ("ADV ..."), the display appears for selecting the tolerance above which the individual components will be corrected.



tol P  
1.5% tol adv

Press the **«Mode» key briefly** several times to select the desired plus/minus tolerance in % (no, 0.5 ... 15.0).

Note: "no" means a tolerance of zero.

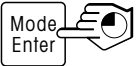

Confirm the selected tolerance (e.g. 1.5%) by pressing the **«Mode» key and holding it down**. The scale is then ready for formula weighing.

**Note:** The selected formula weighing method remains active until you select another.

### 5.4 Terminating and documenting formula weighing



#### Terminating formula weighing

Formula weighing can be terminated at any time by pressing the **«Last Comp» key and holding it down**.



#### Documenting formula weighing

If your scale is connected to a printer, when the formula weighing is complete you can print out the report for the formula weighing by pressing the **«Last Comp» key and holding it down**.

```
Mode :STD ABS END
Components:
co01
  target: 100.0 g
  true  : 110.0 g
co02
  target: 20.0 g
  true  : 22.0 g
co03
  target: 5.0 g
  true  : 5.5 g
```

## 5.5 Formula weighing with "STD ABS END" and "STD CUM END"











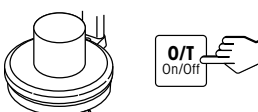

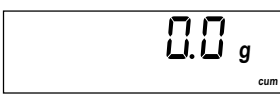
### Procedure







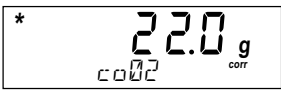



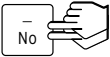





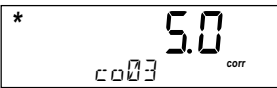

- Place the empty container on the scale and tare.
- Fill and weigh a component to the target weight and confirm the correct weighing with the «Next Comp» key.  
If an excessive quantity of the component is filled, first use the «←» key to enter the target weight of the component and then confirm it with the «Next Comp» key.  
Note: The error will be corrected automatically when the next component is filled.  
Repeat this step until all components have been filled and weighed. Confirm the last component with the «Last Comp» key.
- The scale checks whether extra quantities of any individual components still have to be added. If so, add the extra quantities of the components indicated, confirming each one with the «Next Comp» key.  
Repeat this step until all the extra quantities of components have been added.

When formula weighing is complete, the scale displays "done" and the final weight of the mixture.

### Example

A formula comprises 100 g of component 1, 20 g of component 2, 5 g of component 3.  
No factor has been selected. Component 2 is incorrectly weighed (22.0 g instead of 20.0 g).

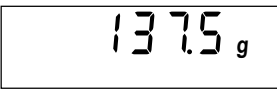
Action	"STD ABS END"	"STD CUM END"
Place empty container on scale and tare 		
Fill and weigh component 1 (target weight 100 g) 		
Confirm component 1 		
Fill and weigh component 2 (target weight 20 g) 	 2 g too much of component 2 are filled	

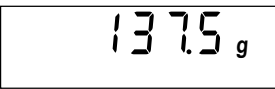
Action	"STD ABS END"	"STD CUM END"
Enter target weight for component 2 20 g (ABS)/120 g (CUM) 		
Confirm target weight 		
Fill and weigh component 3 (target weight 5 g) 		 Note: The error in component 2 is already taken into account when component 3 is weighed, i.e. the actual quantity of component 3 weighed is 5.5 g (instead of 5.0 g). However, adding this extra quantity takes place in the background, i.e. the display shows the target value according to the formula (5.0 g and 125.0 g).
Confirm (last) component 3 		 Note: Because of the error when weighing component 2, an extra 10 g of component 1 must be added.
Add an extra 10 g of component 1 		
Confirm correction 	 	  The formula weighing operation is terminated. The final weight of the mixture is displayed.

## 5.6 Formula weighing with "STD ABS IMM" and "STD CUM IMM"

### Procedure









1. Place empty container on scale and tare.
2. Fill and weigh the component to the target weight and confirm the correct weighing with the «Next Comp» key. If too much of the component is added, first use the «←» key to input the target weight, then confirm with the «Next Comp» key. The error is automatically compensated when the other components are added.
3. Immediately after each component, the scale checks whether extra quantities of the preceding components must be added. If so, add the extra quantities of the components shown, and confirm each time with the «Next Comp» key. Repeat this step until all the extra quantities of components have been added.
4. Repeat steps 2 and 3 until all the components have been added and weighed. Confirm the last component with the «Last Comp» key.

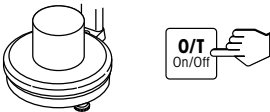
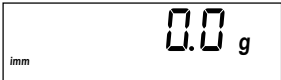
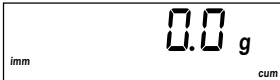



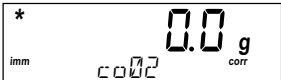





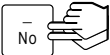

When formula weighing is complete, the scale displays "done" and then the final weight of the mixture.

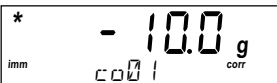
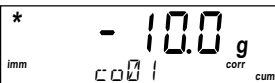
### Example

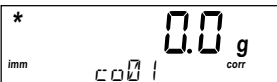
A formula comprises 100 g of component 1, 20 g of component 2, 5 g of component 3.

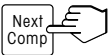
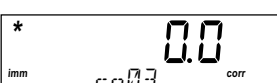
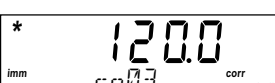
No factor has been selected. Component 2 was weighed incorrectly (22.0 g instead of 20.0 g).

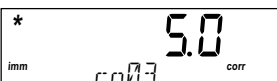
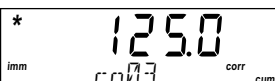
Action	"STD ABS IMM"	"STD CUM IMM"
Place empty container on scale and tare 		
Fill and weigh component 1 (target weight 100 g) 		
Confirm component 1 		
Fill and weigh component 2 (target weight 20 g) 	 2 g too much of component 2 is added	

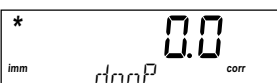
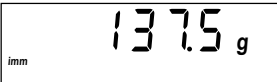
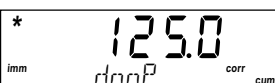
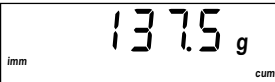
Action	"STD ABS IMM"	"STD CUM IMM"
Enter target value for component 2 20 g (ABS)/120 g (CUM) 		
Confirm target value 	 <p>Note: Because of the error when weighing component 2, an extra 10 g of component 1 must be added.</p>	
Fill an extra 10 g of component 1 		
Confirm the correction 		
Fill and weigh component 3 (target weight 5 g) 	 <p>Note: The error in component 2 is already taken into account when weighing component 3, i.e. the actual quantity of component 3 weighed is 5.5 g (instead of 5.0 g). However, adding this extra quantity takes place in the background, i.e. the display shows the target value according to the formula (5.0 g and 125.0 g).</p>	
3. Confirm (last) component 	 <p>The formula weighing operation is terminated. The final weight of the mixture is displayed.</p> 	 

## 5.7 Formula weighing with "ADV ABS END" and "ADV CUM END"

### Procedure







1. Place empty container on scale and tare.
2. Press **«Next Comp»** key to start formula weighing.
3. Enter the target weight of the component shown digit by digit. (Use the **«+»** and **«-»** keys to enter the digit and then confirm it by briefly pressing the **«Enter»** key). Confirm the target weight entered by pressing the **«Enter»** key and holding it down.
4. Fill and weigh the component to zero and then confirm the weighing with the **«Next Comp»** key (even if the quantity weighed was excessive). If too much of the component was added, the error is automatically compensated when subsequent components are added.
5. Repeat steps 3 and 4 until all the components have been filled and weighed. Confirm the last component with the **«Last Comp»** key.
6. The scale checks whether extra quantities of individual components need to be added. If so, add the extra quantities of the components indicated, confirming each one with the **«Next Comp»** key.  
Repeat this step until all the extra quantities of components have been added.

When formula weighing is complete, the scale displays "done" and the final weight of the mixture.

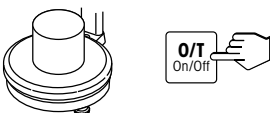
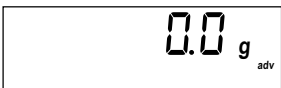
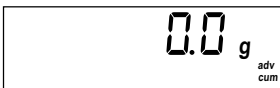



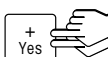

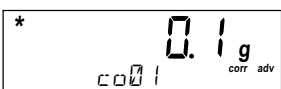
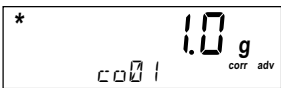
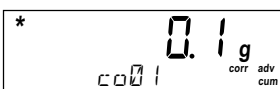
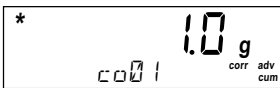







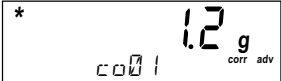

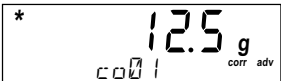

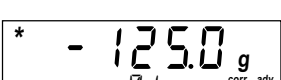
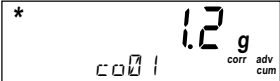

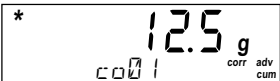

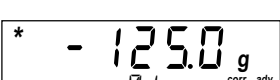

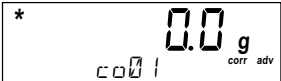
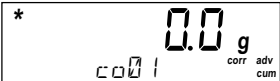
### Example



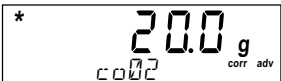
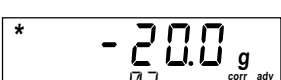
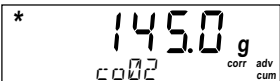
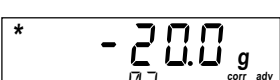

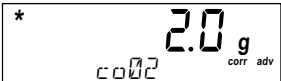
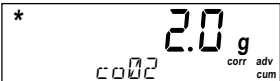





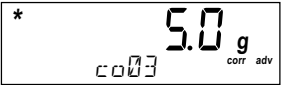
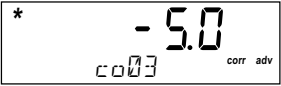

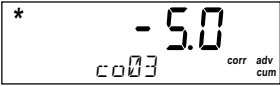
A formula comprises 125 g of component 1, 20 g of component 2, 5 g of component 3.

No factor and no tolerance have been selected. Component 2 was incorrectly weighed (22.0 g instead of 20.0 g).

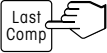
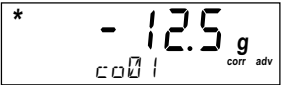
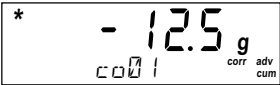
Action	"ADV ABS END"	"ADV CUM END"
Place empty container on scale and tare 		
Start formula weighing 		
Enter target weight of component 1 (125 g) digit by digit  Digit 1   	 	 

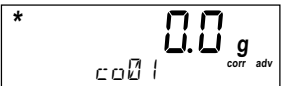
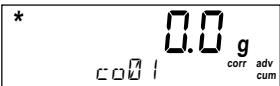

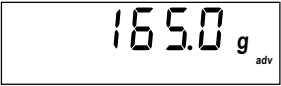
Action	"ADV ABS END"	"ADV CUM END"
Digit 2   Digit 3   Confirm the target weight entered 	    	    
Add and weigh component 1 		
Confirm weighing 		
Target weight of component 2 Enter 20 g (ABS)/145 g (CUM) digit by digit and confirm (for procedure, see component 1) 	 	 
Add and weigh component 2 	 2 g too much of component 2 are added	
Confirm weighing 		

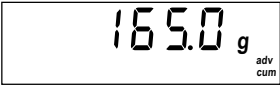
Action	"ADV ABS END"	"ADV CUM END"
<p>Target weight of component 3 Enter 5 g (ABS)/150 g (CUM) digit by digit and confirm (for procedure, see component 1)</p> 	<p>* </p> <p>* </p>	<p>* </p> <p>* </p>
<p>Fill and weigh component 3</p> 	<p>* </p> <p>Note: The error in weighing component 2 is already taken into account when weighing component 3. Although the display shows 0.0, 5.5 g are actually added and weighed.</p>	<p>* </p>
<p>Confirm (last) weighing</p> 	<p>* </p> <p>Note: Because of the error in weighing component 2, an extra 12.5 g of component 1 must be added.</p>	<p>* </p>
<p>Add an extra 12.5 g of component 1</p> 	<p>* </p>	<p>* </p>
<p>Confirm the extra quantity</p> 	<p>* </p> <p>The formula weighing operation is terminated. The final weight of the mixture is displayed.</p> <p></p>	<p>* </p> <p></p>

## 5.8 Formula weighing with "ADV ABS IMM" and "ADV CUM IMM"









### Procedure







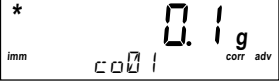
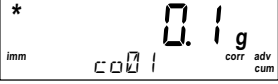

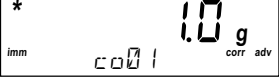
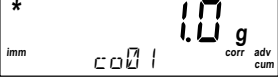





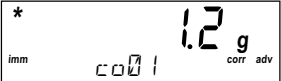

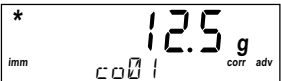

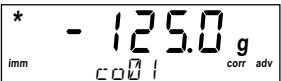
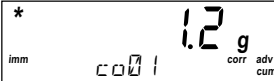

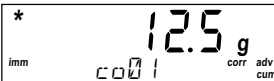

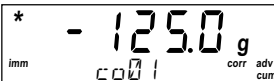

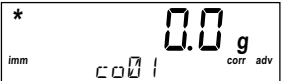

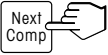
1. Place empty container on scale and tare.
2. Press **«Next Comp»** key to start formula weighing.
3. Enter the target weight of the component shown digit by digit. (Use the **«+»** and **«-»** keys to enter the digit and then confirm it by briefly pressing the **«Enter»** key). Confirm the target weight entered by pressing the **«Enter»** key and holding it down.
4. Fill and weigh the component to zero and then confirm the weighing with the **«Next Comp»** key (even if the quantity weighed was excessive). If too much of the component was added, the error is automatically compensated when the other components are added.
5. Immediately after each component, the scale checks whether extra quantities of the preceding components must be added. If so, add the extra quantities of the components shown, and confirm each time with the **«Next Comp»** key. Repeat this step until all the extra component quantities have been added.
6. Repeat steps 3, 4, and 5 until all components have been filled and weighed. Confirm the last component with the **«Last Comp»** key.











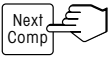
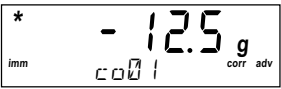
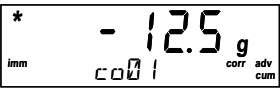

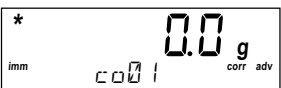
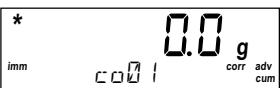
When formula weighing is complete, the scale displays "done", followed by the final weight of the mixture.

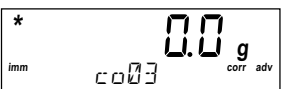
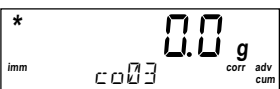
### Example

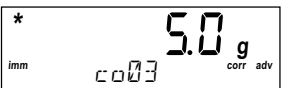
A formula comprises 125 g of component 1, 20 g of component 2, 5 g of component 3.  
No factor or tolerance has been selected. Component 2 is incorrectly weighed (22.0 g instead of 20.0 g).

Action	"ADV ABS IMM"	"ADV CUM IMM"
Place empty container on scale and tare 		
Start formula weighing 		
Enter target weight of component 1 (125 g) digit by digit		
Digit 1 		
		

Action	"ADV ABS IMM"	"ADV CUM IMM"
Digit 2   Digit 3   Confirm the target weight you entered 	    	    
Fill and weigh component 1 		
Confirm weighing 		
Enter target weight of component 2 20 g (ABS)/145 g (CUM) digit by digit and confirm (for procedure, see component 1) 	 	 
Fill and weigh component 2 	 2 g too much of component 2 are filled	

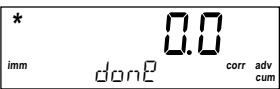
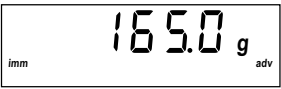
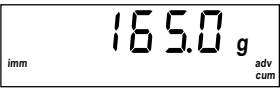
Action	"ADV ABS IMM"	"ADV CUM IMM"
Confirm weighing 		
Note: Because of the error when weighing component 2, an extra 12.5 g of component 1 must be added.		
Add an extra 12.5 g of component 1 		
Confirm the extra quantity 		
Target weight of component 3 Enter 5 g (ABS)/150 g (CUM) digit by digit and confirm (for procedure, see component 1) 		
Fill and weigh component 3 		
Note: The error in weighing component 2 is already compensated when component 3 is weighed. Although the display shows 0.0, the actual amount weighed is 5.5 g.		
Confirm (last) weighing 		
The formula weighing operation is terminated. The actual final weight of the mixture is displayed.		
		

## 6 Master Mode

In Master Mode, the settings of the scale can be changed and functions can be activated.

### 6.1 Calling up Master Mode

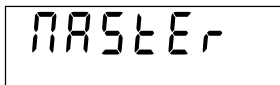

In weighing mode, press the **«Menu»** key and hold it down until the display shown at left appears.

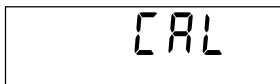
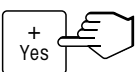

Within 3 seconds, press the **«Yes»** key (otherwise the scale returns to weighing mode). The first menu block of Master mode then appears.

### 6.2 The menus of Master Mode

To operate Master Mode: confirm option with **«Yes»**, reject option with **«No»**.

Display/Settings	Function/Notes
CAL	Calibrate scale (see Section 6.3, not available on certified scales)
SCALE	Scale settings
RESOLU	Select resolution (not available on certified scales)
0.1	"Full Range" 0 ... 7100 g / 0.1 g (factory setting)
0.05	"Delta Range" 0 ... 999.95 g / 0.05 g, 1000 ... 7100 g / 0.1 g
Unit	Select weighing unit (not available on certified scales)
g	Gram (factory setting)
oz	Ounce
P	Parts (1 part = 1/32 oz)
BLIGHT	Switch display lighting on/off
On	Switched on (factory setting)
OFF	Switched off
REMEM	Switch automatic memory function on/off (not available on certified scales)
On	Switched on
OFF	Switched off (factory setting)
VIBRATE	Select vibration adapter
NEd	Normal weighing substances (factory setting)
HIGH	Unstable environment
LOW	Very stable environment
PROCES	Select process adapter
UNWEIR	Normal weighing substances
DOSING	Dosing, e.g. liquid or powder weighing substances (factory setting)
RESET	Reset all SCALE settings to the factory settings
Set On	Reset to factory settings with <b>«Yes»</b> , reject with <b>«No»</b>
End SC	Quit "SCALE" block with <b>«Yes»</b>

Display/Settings	Function/Notes
IFACE 1 / IFACE 2	Configure interface(s)
Mode	Select mode
<b>d IALOG</b>	Communication with computer (factory setting IFACE 1)
2nd d IS	Control of auxiliary display (factory setting IFACE 2)
PN	PM scale emulation
Print	Communication with printer
CYCLE	Data printout when weight changes
Protocol	Select protocol
<b>HOFF</b>	Xon/Xoff protocol (factory setting)
NO	No protocol
PARITY	Select bits and parity
7 EVEN	7 data bits with even parity
7 NO P	7 data bits with no parity
<b>8 NO P</b>	8 data bits with no parity (factory setting)
7 Odd	7 data bits with odd parity
BRUD	Select data transmission rate
300	300, 600, 1200, 2400, 4800, <b>9600</b> (factory setting),
⋮	19200 and 38400
38400	
AutoMod	Automatic mode
<b>AUTS IF</b>	Interface continuously transmits data (factory setting IFACE 1)
NO	Automatic mode switched off (factory setting IFACE 2)
RESET	Reset IFACE setting to factory settings
Std On	Reset factory settings with «Yes», reject with «No».
End IF 1	Quit "IFACE1" or "IFACE2" block with «Yes»
List	Print out Master Mode settings with «Yes»
End	Quit Master Mode with «Yes». Answer "StorE?" with «Yes» to save settings or «No» to reject them.

### 6.3 Adjusting/calibrating the scale (not available on certified scales)

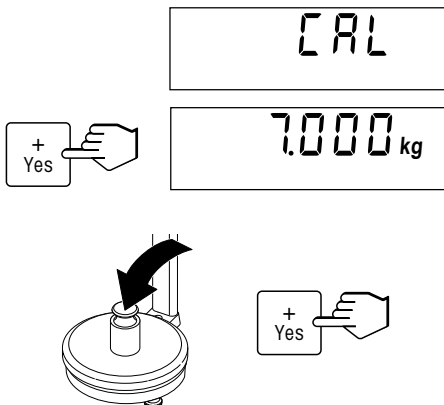

Call up Master Mode and select "CAL".

Unload the weighing pan and then press the «Yes» key to start the calibration procedure.

The scale flashes the calibration weight (corresponding to the nominal load of the scale). If desired, the «No» key can be used to select other calibration weights.

Place the calibration weight shown in the display on the scale and confirm with «Yes».

Note: Calibration can be **terminated** at any time by pressing the «On/Off» key and holding it down.

Wait until the calibration terminates successfully (the display shows "done") and the scale returns to weighing mode.

## 7 Error messages



### Overload

Unload the scale or reduce the preload.

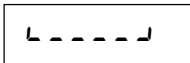

### Underload

Place the weighing pan on the scale and ensure that it can move freely.



### Weighing result never becomes stable

1. Ensure the environment is stable
2. Ensure the weighing pan can move freely
3. Change the setting of the vibration adapter (Section 6.2)

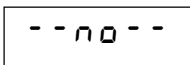

### Function not executed

The called function could not be executed.

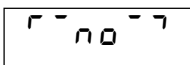

### Zero setting not possible (overload/underload)

Ensure that zeroing is not done with overload or underload.

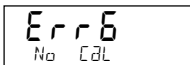

### No calibration/adjustment

Unplug power plug and plug in again. If message reappears, calibrate/adjust scale (Section 6.3). If this still does not help, contact your authorized METTLER TOLEDO representative.

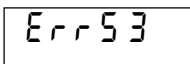

### EAROM checksum error

Unplug power plug and plug in again. If message reappears, contact your authorized METTLER TOLEDO representative.



### Undervoltage

The output voltage of the AC adapter is too low. Replace with an AC adapter with the correct output voltage.



### Readability

The resolution of the target weight which was entered when formula weighing is too fine. Adjust to the readability of the scale (e.g. 15.01 g is entered with a readability of 0.05 g).

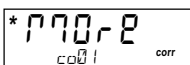

### Target quantity not yet reached

The target quantity of the component has not yet been reached. Add more of the component until the target quantity is reached.



### Formula weighing terminated

Formula weighing has been terminated by pressing the «Last Comp» key and holding it down.



## 8 Interfaces / accessories

### 8.1 Interface definition

As standard equipment the PS7 scale has a double RS232C interface while the PS7-X has a single RS232C interface. The interface(s) are available via the 9-pin sub-D socket. The maximum cable length is 15 m. The interfaces are configured in Master Mode (see Section 6.2).

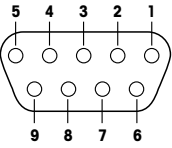
Built-in interface(s) RS232C, 9-pin D-sub, f		Assignment on PS7	Assignment on PS7-X	2 interfaces with use of Y cable (accessory), PS7 only	
Assignments				COM1	COM2
	Pin 1	nc	nc	—	—
	Pin 2	TxD 1	TxD 1	TxD 1	TxD 2
	Pin 3	RxD 1	RxD 1	RxD 1	RxD 2
	Pin 4	nc	nc	—	—
	Pin 5	GND	GND	GND	GND
	Pin 6	nc	nc	—	—
	Pin 7	RxD 2	nc	—	—
	Pin 8	TxD 2	nc	—	—
	Pin 9	VCC (5V, ≤50mA)	nc	—	VCC (5V, ≤50mA)

TxD: Transmit data

GND: Signal ground

nc: Not connected

RxD: Receive data

VCC: Voltage (+5V, ≤50mA)

### 8.2 Accessories

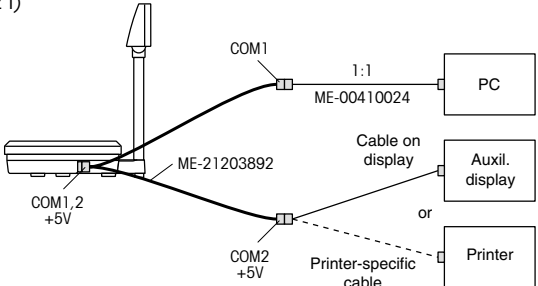
Accessory	Art. no.
Protective cover (set of 5)	21302841
Y-cable (9-pin D-sub, m, COM1/2 f)  	21203892
RS232 cable for PC 1.8 m (9-pin D-sub, m/f, 1:1)	00410024

## 9 Technical data / guidelines and test standards

### 9.1 Technical data

Max. capacity	7100 g
Readability	Full Range: 0.1 g (0 ... 7100 g) Delta Range: 0.05 g (0 ... 999.95 g), 0.1 g (1000 ... 7100 g)
Stabilization time	Approx. 1.0 seconds
Linearity	0.2 g
Power supply	Via AC adapter/power supply unit 13.5 VAC, 4 watt
Weighing units	g, oz and P (1 part = 1/32 oz)
Display	LCD (liquid crystal display), backlit
Environmental conditions	Temperature range: +10 ... +30°C Relative air humidity: 20 ... 80% rF (non-condensing)
Weight net/gross	3.4 kg / 4.5 kg
Overvoltage category:	II
Pollution degree:	2

### Dimensions

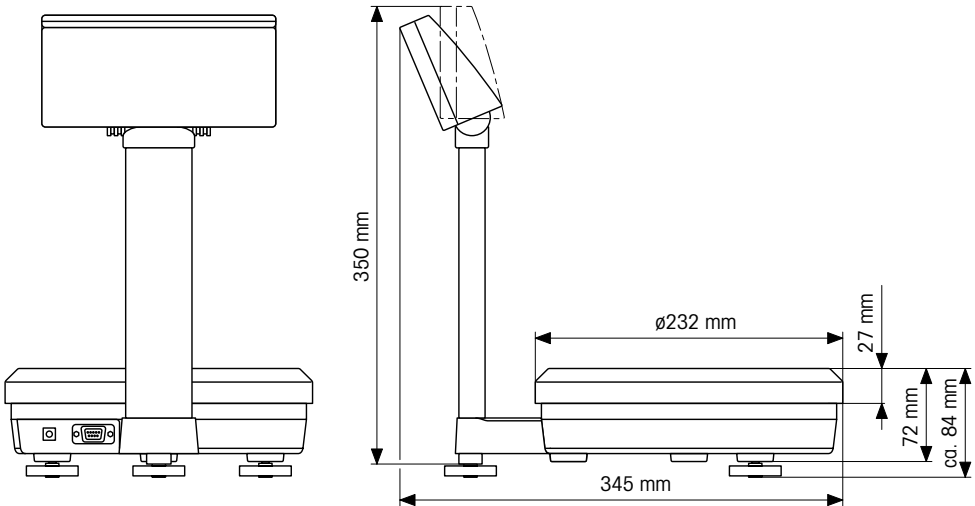



## 9.2 Directives and test standards

### Scale line PS7

We declare with sole responsibility that the product to which this declaration relates conforms with the EU directives stated below.

Note: EU pattern approval has been obtained for certified scales. The year of first certification is shown adjacent to the CE marking. Such scales are certified at the factory and bear the mark «M» on the instrument itself and on the packaging. If the letter M appears on a solid ground, the scale may be used immediately. If the ground is broken and hatched, the scale must be certified locally at the place of use by the certified METTLER TOLEDO Service. If the national regulations of individual countries limit the period of validity of the certification, the operator of such a scale is responsible for its timely recertification.

Marking	EU directive	Tested to standard
	73/23EEC low voltage	EN61010-1  CAN/CSA-22.2 No. 1010.1-92
	89/336EEC EMC	EN61326-1 Emission Cl. B EN61000-3-2 Harmonic Oscillations EN61000-3-3 Voltage Fluctuations EN61326-1 Immunity (Industrial) AS/NZS2064.1/2, AS/NZS3548 AS/NZS4251.1, AS/NZS4252.1
	90/384EEC <sup>1)</sup> Non-automatic Scales	EN45501 <sup>1)</sup> Metrological Aspects

<sup>1)</sup> Applies only to certified scales

Mettler-Toledo GmbH  
Industrial BA IND-N  
Nänikon, May 2001

Johannes Schmid  
General Manager  
Standard Industrial

Marlise Ackermann  
Project Manager  
Product Area General Weighing

### USA

*This equipment has been tested and found to comply with the limits for a Class A digital device, pursuant to both Part 15 of the FCC Rules and the radio interference regulations of the Canadian Department of Communications. These limits are designed to provide reasonable protection against harmful interference when the equipment is operated in a commercial environment. This equipment generates, uses and can radiate radio frequency energy and, if not installed and used in accordance with the instruction manual, may cause harmful interference to radio communications. Operation of this equipment in a residential area is likely to cause harmful interference, in which case the user will be required to correct the interference at his own expense.*

### Canada







*ICES-001 Notice for Industrial, Scientific and Medical Radio Frequency Generators: This ISM apparatus meets all requirements of the Canadian Interference-Causing Equipment Regulations. Please note that this requirement is only for generators which operate at over 10 kHz.*

*Avis de l'ICES-001, générateurs de radiofréquences dans le domaine industriel, scientifique et médical: Cet appareil ISM (industriel, scientifique et médical) satisfait à toutes les exigences définies par la réglementation canadienne en matière d'équipements générant des perturbations radioélectriques. Veuillez noter qu'il s'agit d'une exigence concernant uniquement les générateurs fonctionnant au-delà de 10 kHz.*

**Scale line PS7-X**

We declare with sole responsibility that the product to which this declaration relates conforms with the EU directives stated below.

Note: EU pattern approval has been obtained for certified scales. The year of first certification is shown adjacent to the CE marking. Such scales are certified at the factory and bear the mark «M» on the instrument itself and on the packaging. If the letter M appears on a solid ground, the scale may be used immediately. If the ground is broken and hatched, the scale must be certified locally at the place of use by the certified METTLER TOLEDO Service. If the national regulations of individual countries limit the period of validity of the certification, the operator of such a scale is responsible for its timely recertification.

Marking	EU directive	Tested to standard
  	94/9/EEC (ATEX)	EN50014, EN50020  FMRC 3600, 3610, 3810  CSA-C22.2 No. 157-92 CSA-C22.2 No. 142-M 1987
	73/23EEC low voltage	EN60950-1
 	89/336EEC EMC	EN61326-1 Emission Cl. B EN61000-3-2 Harmonic Oscillations EN61000-3-3 Voltage Fluctuations EN61326-1 Immunity (Industrial)  AS/NZS2064.1/2, AS/NZS3548 AS/NZS4251.1, AS/NZS4252.1

Mettler-Toledo GmbH  
 Industrial BA IND-N  
 Nänikon, May 2001

Johannes Schmid  
 General Manager  
 Standard Industrial

Marlise Ackermann  
 Project Manager  
 Product Area General Weighing

**USA**

*This equipment has been tested and found to comply with the limits for a Class A digital device, pursuant to both Part 15 of the FCC Rules and the radio interference regulations of the Canadian Department of Communications. These limits are designed to provide reasonable protection against harmful interference when the equipment is operated in a commercial environment. This equipment generates, uses and can radiate radio frequency energy and, if not installed and used in accordance with the instruction manual, may cause harmful interference to radio communications. Operation of this equipment in a residential area is likely to cause harmful interference, in which case the user will be required to correct the interference at his own expense.*

**Canada**

*ICES-001 Notice for Industrial, Scientific and Medical Radio Frequency Generators: This ISM apparatus meets all requirements of the Canadian Interference-Causing Equipment Regulations. Please note that this requirement is only for generators which operate at over 10 kHz.*

*Avis de l'ICES-001, générateurs de radiofréquences dans le domaine industriel, scientifique et médical: Cet appareil ISM (industriel, scientifique et médical) satisfait à toutes les exigences définies par la réglementation canadienne en matière d'équipements générant des perturbations radioélectriques. Veuillez noter qu'il s'agit d'une exigence concernant uniquement les générateurs fonctionnant au-delà de 10 kHz.*

# 1 Einleitung

## 1.1 Allgemein

Wir danken Ihnen, dass Sie die **Farbmischwaage PS7 bzw. deren explosionsgeschützte Variante PS7-X** erworben haben. Mit der PS7/PS7-X lassen sich Komponenten mit einem zuvor festgelegten Mischverhältnis einwiegen. Die Waage besitzt verschiedene Korrekturmodi, um allfällig fehlerhaft eingewogene Komponenten zu kompensieren. Über die eingebaute RS232-Schnittstelle kann die Waage an einen Drucker angeschlossen oder mit einem Rechner oder mit einer Zweitanzeige verbunden werden.

Bitte lesen Sie diese Bedienungsanleitung sorgfältig durch und halten Sie sich an die Anweisungen!

## 1.2 Sicherheit und Umwelt



- **PS7-Waage nicht in explosionsgefährdeter Umgebung** (mit explosionsgefährdeten Gemischen von Gasen, Dämpfen, Nebeln und Stäuben) betreiben.

Für **explosionsgefährdete Zonen** ist eine Waage des Typs **PS7-X** zu verwenden. Diese Waagen müssen **zwingend über das zertifizierte Speisegerät** von METTLER TOLEDO angeschlossen werden. Die Hinweise in der Installationsanleitung zum Speisegerät sind unbedingt zu beachten und einzuhalten. Die Verwendung einer Schutzhülle in explosionsgefährdeten Zonen ist wegen der Gefahr elektrostatischer Aufladung nur zulässig, wenn sie aus statisch unbedenklichem Material besteht.

- Waage **nur mit dem mitgelieferten Netzadapter (PS7)** bzw. mit dem **Speisegerät (PS7-X)** ans Stromnetz anschliessen. Sicherstellen, dass der aufgedruckte Spannungswert mit der lokalen Netzspannung übereinstimmt. Kabel des Netzadapters/Speisegerätes regelmässig überprüfen. Sind die Kabel oder ist der Netzadapter/das Speisegerät beschädigt, darf die Waage nicht weiter betrieben werden.
- Nur empfohlenes Zubehör und Peripheriegeräte verwenden.
- Waage sorgfältig behandeln, sie ist ein Präzisionsinstrument. Schläge auf die Waagschale sowie das Auflegen hoher Überlasten beschädigen die Waage.
- **Waage vor Beginn der Reinigungsarbeiten vom Stromnetz trennen!**  
Reinigung: Feuchten Lappen verwenden (keine Säuren, Laugen oder Lösungsmittel). Bei starker Verschmutzung Waagschale, Schutzhülle (falls vorhanden) und Stellfüsse (nur bei geeichten Waagen) entfernen und separat reinigen. Betriebsinterne und branchenspezifische Vorschriften betreffend Reinigungsintervalle und zulässige Reinigungsmittel beachten.
- Für die Entsorgung der Waage die geltenden Umweltvorschriften beachten.

## 1.3 Hinweise zu geeichten Modellen

Bei geeichten Modellen sind die folgenden Funktionen deaktiviert:

- Rezeptieren (Faktorwägen und Rezeptieren mit Korrektur)
- Ändern der Wägeinheit (Wägeinheit bei Eichwaagen standardmässig auf "g" eingestellt)
- Kalibrierung (Geeichte Modelle müssen durch eine autorisierte METTLER TOLEDO Servicestelle justiert/kalibriert werden)

## 2 Inbetriebnahme

### 2.1 Waage aufstellen und ausrichten

Der richtige Standort trägt entscheidend zur Genauigkeit der Wägeregebnisse bei!



Stabile, erschütterungsfreie und möglichst horizontale Lage wählen.

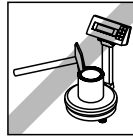

Verschliessen Sie Farbdosen, die sich noch auf der Waagschale befinden niemals mit einem Hammer.



Vermeiden Sie übermässige Temperaturschwankungen und direkte Sonnenbestrahlung. Umgebungsbedingungen beachten.

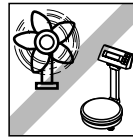

Vermeiden Sie Zugluft (z.B. von Ventilatoren oder Klimaanlage).

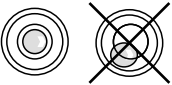

**Nur Eichwaage:** Waage durch Drehen der Stellfüsse horizontal ausrichten. Die Luftblase muss innerhalb des inneren Kreises liegen.

Hinweis: Eichwaagen müssen am Aufstellungsort durch eine autorisierte METTLER TOLEDO Servicestelle justiert werden.

#### Grössere geografische Standortänderungen

Wir empfehlen Ihnen, bei der ersten Inbetriebnahme die Waage zu kalibrieren (siehe Kapitel 6.3). Geeichte Waagen müssen unter Beachtung der nationalen Eichvorschriften vor Ort geeicht werden.

### 2.2 Stromversorgung anschliessen

**PS7-X für explosionsgefährdete Zonen:** Die Waagen des Typs PS7-X für explosionsgefährdete Zonen dürfen nur über ein zertifiziertes Speisegerät angeschlossen werden. Beachten und befolgen Sie deshalb unbedingt die Hinweise in der separaten Installationsanleitung zum Speisegerät.

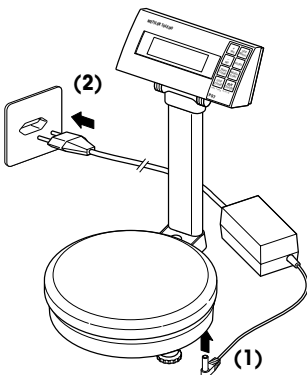









**Achtung!** Vor dem Anschluss des Netzadapters prüfen, ob der aufgedruckte Spannungswert mit der örtlichen Netzspannung übereinstimmt.

**Wichtig!** Zuerst Netzadapter mit der Buchse an der Waagenunterseite verbinden (1). Erst dann Stecker des Netzadapters in die Steckdose einstecken (2).

Nach dem Anschliessen führt die Waage einen Anzeigetest durch, bei dem alle Segmente und anschliessend die Softwareversion kurz angezeigt werden. Sobald die Nullanzeige erscheint, ist die Waage betriebsbereit.

### 3 Tastenfunktionen

Taste	Funktion bei	
	Kurzdruck	Langdruck
	Waage tarieren **	Waage ein- bzw. ausschalten **
	Umrechnungsfaktor wählen, um eine kleinere oder grössere Menge eines Rezeptes einzuwägen	Zurücksetzen des Umrechnungsfaktors auf "1" (Wägen ohne Faktor)
	Ändern der Wägeeinheit	Einstieg in den Mastermode ** (siehe Kapitel 6.1)
	Bestätigen des Zielgewichtes einer eingewogenen Komponente und weiterfahren mit der nächsten Komponente	—
	Bestätigen des Zielgewichtes der letzten eingewogenen Komponente eines Rezeptes	Rezeptiervorgang abrechnen
	Rezeptiermethode oder Toleranz auswählen <b>Advanced-Rezeptiermodus</b> Nächste Ziffer des Zielgewichtes setzen	Gewählte Rezeptiermethode bestätigen oder gewählte Toleranz bestätigen <b>Advanced-Rezeptiermodus</b> Eingegebenes Zielgewicht bestätigen
	Funktion abhängig vom aktuell gewählten Arbeitsmodus <b>Mastermode **</b> Bestätigen der aktuellen Einstellung <b>Standard-Rezeptiermodus</b> Sollwert der Komponente erhöhen <b>Advanced-Rezeptiermodus</b> Sollwert der Komponente erhöhen	<b>Mastermode</b> — <b>Standard-Rezeptiermodus</b> Sollwert der Komponente um 1.0 erhöhen <b>Advanced-Rezeptiermodus</b> —
	Funktion abhängig vom aktuell gewählten Arbeitsmodus <b>Mastermode **</b> Verwerfen der aktuellen Einstellung <b>Standard-Rezeptiermodus</b> Sollwert der Komponente verringern <b>Advanced-Rezeptiermodus</b> Sollwert der Komponente verringern	<b>Mastermode</b> — <b>Standard-Rezeptiermodus</b> Sollwert der Komponente um 1.0 verringern (bei gedrückt gehaltener Taste wird der Wert automatisch weiter verringert) <b>Advanced-Rezeptiermodus</b> Zurück zur letzten Ziffer

\*\* Bei Eichwaagen sind nur diese Tasten aktiv

## 4 Wägen

### 4.1 Ein-/Ausschalten und Wägeeinheit wählen

#### Ein-/Ausschalten



Durch **langes Drücken** der Taste **«On/Off»** schalten Sie die Waage ein bzw. aus. Nach dem Einschalten führt die Waage einen Anzeigetest durch. Sobald die Gewichtsanzeige erscheint, ist die Waage wägebereit und automatisch auf Null gestellt.

#### Wägeeinheit wählen (bei Eichwaagen nicht verfügbar)



Durch **kurzes Drücken** der Taste **«Unit»** kann die Wägeeinheit zwischen "g" (Gramm), "oz" (Unze) und "P" (Parts) umgeschaltet werden.

### 4.2 Einfaches Wägen

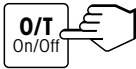
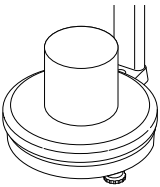

Wägebehälter auflegen. Zum Trieren, kurz die Taste **«O/T»** drücken. Die Nullanzeige erscheint.

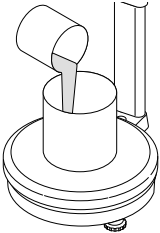

Gewünschte Menge des Wägegutes einfüllen.

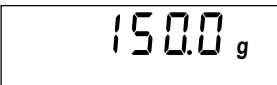

Warten bis die Stillstandskontrolle (Ringsymbol in der Anzeige) erlischt und Wägeresultat ablesen.



## 5 Rezeptieren

Hinweis: **Bei Eichwaagen sind die Rezeptierfunktionen deaktiviert** (Faktorwägen, Rezeptieren mit Korrektur).

### 5.1 Faktor wählen

Um eine grössere oder kleinere Menge eines vorgegebenen Rezeptes einzuwägen, kann ein Faktor (Multiplikator) gewählt werden.



Durch **kurzes Drücken** der Taste **«Factor»** aktivieren Sie die Faktorwägung.

In der Anzeige erscheint unten links der bei der letzten Faktorwägung verwendete Faktor (z.B. 0.50).

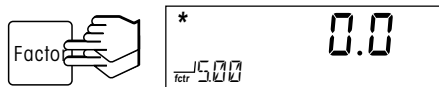

Drücken Sie anschliessend **mehrmals kurz** die Taste **«Factor»**, bis der gewünschte Faktor (0.20 ... 5.00) angezeigt wird.

Bei der anschliessenden Wägung wird auf das Zielgewicht (z.B. 1000 g) einer Komponente gemäss Rezept eingewogen. Abhängig vom gewählten Faktor wird effektiv jedoch eine um den Faktor kleinere oder grössere Menge eingewogen.

**Beispiel 1:** Gewicht gemäss Rezept 1000 g, gewählter Faktor 0.50 (für halbe Menge). Anzeige: 1000, effektiv eingewogen: 500 g

**Beispiel 2:** Gewicht gemäss Rezept 1000 g, gewählter Faktor 3.00 (für dreifache Menge). Anzeige: 1000, effektiv eingewogen: 3000 g



**Faktorwägung deaktivieren:** Durch **langes Drücken** der Taste **«Factor»** deaktivieren Sie die Faktorwägung.

Die Faktoranzeige verschwindet und der Faktor wird auf 1 zurückgesetzt.

## 5.2 Die verschiedenen Rezeptiermethoden

Die PS7 bietet verschiedene Rezeptiermethoden an. Jede Rezeptiermethode setzt sich zusammen aus:

- dem **Rezeptiermodus**:
  - **“ST” Standard-Rezeptieren**: In diesem Modus wird die gewünschte Menge einer Komponente eingewogen und bestätigt. Bei einer Fehldosierung ist vor dem Einwiegen der nächsten Komponente das effektive Zielgewicht der falsch eingewogenen Komponente einzugeben. Der Fehler wird beim Einwiegen nachfolgender Komponenten automatisch berücksichtigt.
  - **“ADV” Advanced-Rezeptieren**: In diesem Modus wird zuerst das Zielgewicht einer Komponente eingegeben. Anschliessend wird die Komponente eingewogen und bestätigt. Ein allfälliger Einwägefehler wird beim Zuwiegen nachfolgender Komponenten automatisch berücksichtigt.
- der **Anzeigeart**:
  - **“ABS” Absolut-Anzeige**: Anzeige des absoluten Gewichtes einer Komponente.
  - **“CUM” Kumulativ-Anzeige**: Anzeige des kumulierten Gewichtes.
- dem **Korrekturmodus**:
  - **“IMM” Korrektur**: Korrektur unmittelbar nach jeder falsch eingewogenen Komponente
  - **“END” Korrektur**: Korrektur am Schluss der Rezeptierung

Durch Kombination resultieren **8 verschiedene Rezeptiermethoden**:

Rezeptiermethode	Rezeptiermodus		Anzeigeart		Korrekturmodus	
	Standard	Advanced	Absolut	Kumulativ	unmittelbar	am Schluss
ST ABS END → Kap. 5.5	X		X			X
ST CUM END → Kap. 5.5	X			X		X
ST ABS IMM → Kap. 5.6	X		X		X	
ST CUM IMM → Kap. 5.6	X			X	X	
ADV ABS END → Kap. 5.7		X	X			X
ADV CUM END → Kap. 5.7		X		X		X
ADV ABS IMM → Kap. 5.8		X	X		X	
ADV CUM IMM → Kap. 5.8		X		X	X	

### 5.3 Rezeptiermethode wählen



Corr P  
STD ABS END

Taste **«Mode» kurz drücken**. Die zuletzt angewählte Rezeptiermethode erscheint in der Anzeige (ab Werk: "STD ABS END").



Corr P  
ADV ABS END

Durch wiederholtes, **kurzes Drücken** der Taste **«Mode»**, die gewünschte Rezeptiermethode (z.B. "ADV ABS END") auswählen.

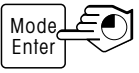

tol P  
1.5 % tol adv

Gewählte Rezeptiermethode durch **langes Drücken** der Taste **«Mode»** bestätigen.

Falls Sie eine Advanced-Rezeptiermethode ("ADV ...") gewählt haben, erscheint die Anzeige für die Auswahl der Toleranz, bei deren Überschreitung die einzelnen Komponenten korrigiert werden sollen.



tol P  
1.5 % tol adv

Durch wiederholtes, **kurzes Drücken** der Taste **«Mode»**, die gewünschte Plus/Minus-Toleranz in % (no, 0.5 ... 15.0) auswählen.

Hinweis: "no" bedeutet eine Toleranz von Null.

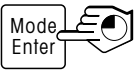

Gewählte Toleranz (z.B. 1.5%) durch **langes Drücken** der Taste **«Mode»** bestätigen. Die Waage ist anschließend bereit für die Rezeptierung.

**Hinweis:** Die gewählte Rezeptiermethode bleibt aktiv, bis eine andere angewählt wird.

### 5.4 Hinweise zum Rezeptieren

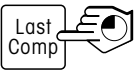

#### Rezeptierung abbrechen

Eine Rezeptierung kann jederzeit durch **langes Drücken** der Taste **«Last Comp»** abgebrochen werden.

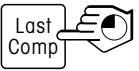

#### Rezeptierprotokoll ausdrucken

Falls Ihre Waage mit einem Drucker verbunden ist, kann nach Abschluss einer Rezeptierung durch **langes Drücken** der Taste **«Last Comp»** das entsprechende Rezeptierprotokoll ausgedruckt werden.

```
Mode :STD ABS END
Components:
co01
  target: 100.0 g
  true  : 110.0 g
co02
  target: 20.0 g
  true  : 22.0 g
co03
  target: 5.0 g
  true  : 5.5 g
```











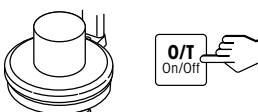

## 5.5 Rezeptieren mit "STD ABS END" und "STD CUM END"

### Ablauf











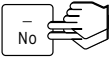





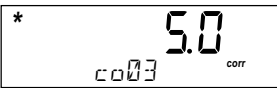

1. Leeren Behälter auflegen und tarieren.
  2. Komponente auf das Zielgewicht einwiegen und korrekte Einwägung mit der Taste **«Next Comp»** bestätigen.  
 Falls die Komponente überfüllt wurde, zuerst mit der Taste **«←»** das Sollgewicht der Komponente eingeben und mit Taste **«Next Comp»** bestätigen.  
 Hinweis: Der Fehler wird beim Einfüllen nachfolgender Komponenten automatisch berücksichtigt.  
 Diesen Schritt wiederholen, bis alle Komponenten eingewogen sind. Letzte Komponente mit der Taste **«Last Comp»** bestätigen.
  3. Die Waage prüft, ob einzelne Komponenten nachdosiert werden müssen. Falls ja: Angezeigte Komponenten nachdosieren und jeweils mit der Taste **«Next Comp»** bestätigen.  
 Diesen Schritt wiederholen, bis alle Komponenten nachdosiert sind.
- Nach Beendigung der Rezeptierung zeigt die Waage "done", danach das Endgewicht der Mischung.

### Beispiel

Rezeptur bestehend aus: 1. Komponente 100 g, 2. Komponente 20 g, 3. Komponente 5 g  
 Kein Faktor angewählt. Die 2. Komponente wird falsch eingewogen (22.0 g statt 20.0 g)

Aktion	"STD ABS END"	"STD CUM END"
Leeren Behälter auflegen und tarieren 		
1. Komponente einfüllen (Sollwert 100 g) 		
1. Komponente bestätigen 		
2. Komponente einfüllen (Sollwert 20 g) 	 2. Komponente wird um 2 g überfüllt	

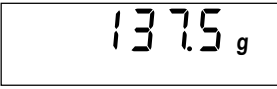
Deutsch

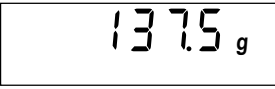
Aktion	"STD ABS END"	"STD CUM END"
Sollwert für 2. Komponente eingeben 20 g (ABS)/120 g (CUM) 		
Sollwert bestätigen 		
3. Komponente einfüllen (Sollwert 5 g) 	 <p data-bbox="465 582 1043 715">Hinweis: Der Fehler beim Einwägen der 2. Komponente wird beim Einwägen der 3. Komponente bereits berücksichtigt, d. h. es werden für die 3. Komponente effektiv 5.5 g (statt 5.0 g) eingewogen. Diese Überdosierung erfolgt jedoch im Hintergrund, d.h. in der Anzeige wird der Sollwert gemäss Rezept (5.0 bzw. 125.0) angezeigt.</p>	
3. (Letzte) Komponente bestätigen 	 <p data-bbox="465 839 1043 890">Hinweis: Aufgrund des Fehlers beim Einwägen der 2. Komponente muss die 1. Komponente um 10 g nachdosiert werden.</p>	
1. Komponente um 10 g nachdosieren 		
Korrektur bestätigen 	 <p data-bbox="465 1193 1043 1244">Der Rezeptvorgang wird beendet. Das Endgewicht der Mischung wird angezeigt.</p> 	 

## 5.6 Rezeptieren mit "STD ABS IMM" und "STD CUM IMM"









### Ablauf

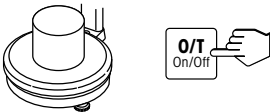





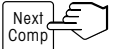
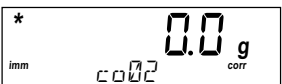

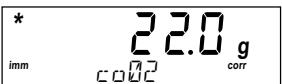
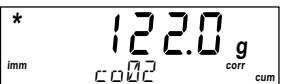

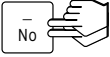

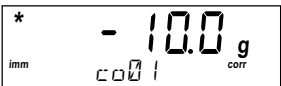
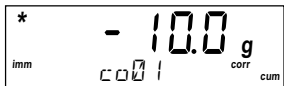

1. Leeren Behälter auflegen und tarieren.
2. Komponente auf das Zielgewicht einwiegen und korrekte Einwägung mit der Taste «Next Comp» bestätigen.  
Falls die Komponente überfüllt wurde, zuerst mit der Taste «←» das Sollgewicht der Komponente eingeben und mit Taste «Next Comp» bestätigen. Der Fehler wird beim Einfüllen nachfolgender Komponenten automatisch berücksichtigt.
3. Die Waage prüft unmittelbar nach jeder Komponente, ob die vorgängig eingewogenen Komponenten nachdosiert werden müssen. Falls ja: Angezeigte Komponenten nachdosieren und jeweils mit der Taste «Next Comp» bestätigen. Diesen Schritt wiederholen, bis alle Komponenten nachdosiert sind.
4. Schritte 2 und 3 wiederholen, bis alle Komponenten eingewogen sind. Letzte Komponente mit der Taste «Last Comp» bestätigen.

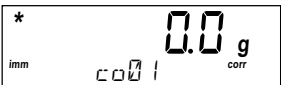
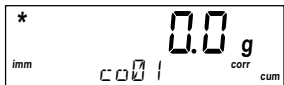
Nach Beendigung der Rezeptierung zeigt die Waage "done", danach das Endgewicht der Mischung.

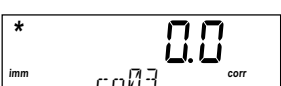
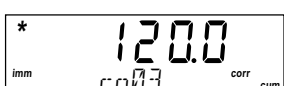
### Beispiel

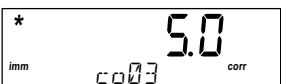
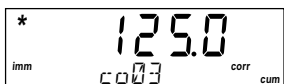
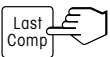
Rezeptur besteht aus: 1. Komponente 100 g, 2. Komponente 20 g, 3. Komponente 5 g  
Kein Faktor angewählt. Die 2. Komponente wird falsch eingewogen (22.0 g statt 20.0 g)

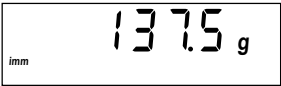
Aktion	"STD ABS IMM"	"STD CUM IMM"
Leeren Behälter auflegen und tarieren 		
1. Komponente einfüllen (Sollwert 100 g) 		
1. Komponente bestätigen 		
2. Komponente einfüllen (Sollwert 20 g) 	 <p style="text-align: center;">2. Komponente wird um 2 g überfüllt</p>	

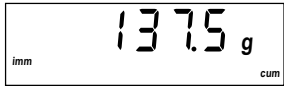
Aktion	"STD ABS IMM"	"STD CUM IMM"
Sollwert für 2. Komponente eingeben 20 g (ABS)/120 g CUM 		
Sollwert bestätigen 	 <p data-bbox="468 464 1050 512">Hinweis: Aufgrund des Fehlers beim Einwiegen der 2. Komponente muss die 1. Komponente um 10 g nachdosiert werden.</p>	
1. Komponente um 10 g nachdosieren 		
Korrektur bestätigen 		
3. Komponente einfüllen (Sollwert 5 g) 	 <p data-bbox="468 932 1050 1062">Hinweis: Der Fehler beim Einwiegen der 2. Komponente wird beim Einwiegen der 3. Komponente bereits berücksichtigt, d. h. es werden für die 3. Komponente effektiv 5.5 g (statt 5.0 g) eingewogen. Diese Überdosierung erfolgt jedoch im Hintergrund, d.h. in der Anzeige wird der Sollwert gemäss Rezept (5.0 bzw. 125.0) angezeigt.</p>	
3. (letzte) Komponente bestätigen 	 <p data-bbox="468 1187 1050 1235">Der Rezeptvorgang wird beendet. Das Endgewicht der Mischung wird angezeigt.</p> 	 

## 5.7 Rezeptieren mit "ADV ABS END" und "ADV CUM END"









### Ablauf

1. Leeren Behälter auflegen und tarieren.
2. Taste «Next Comp» drücken, um mit dem Rezeptieren zu beginnen.
3. Zielgewicht der angezeigten Komponente ziffernweise eingeben (mit Taste «+» bzw. «-» Ziffer setzen und gesetzte Ziffer durch kurzes Drücken der Taste «Enter» bestätigen). Eingegebenes Zielgewicht durch langes Drücken der Taste «Enter» bestätigen.
4. Komponente gegen Null einwiegen und Einwägung (auch bei Überfüllung) mit der Taste «Next Comp» bestätigen. Falls die Komponente überfüllt wurde, wird der Fehler beim Einfüllen nachfolgender Komponenten automatisch berücksichtigt.
5. Schritte 3 und 4 wiederholen, bis alle Komponenten eingewogen sind. Letzte Komponente mit der Taste «Last Comp» bestätigen.
6. Die Waage prüft, ob einzelne Komponenten nachdosiert werden müssen. Falls ja: Angezeigte Komponenten nachdosieren und jeweils mit der Taste «Next Comp» bestätigen.  
Diesen Schritt wiederholen, bis alle Komponenten nachdosiert sind.





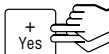
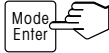

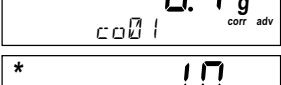
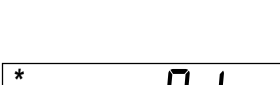
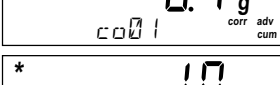



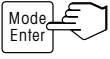
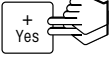

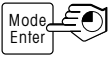

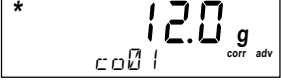
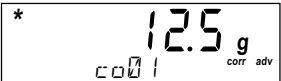

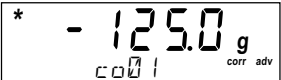

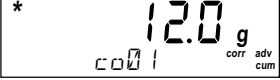
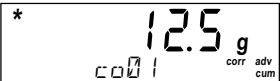

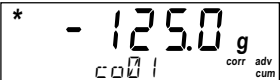



Nach Beendigung der Rezeptierung zeigt die Waage "done", danach das Endgewicht der Mischung.



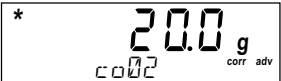



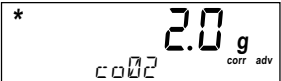
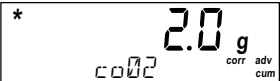
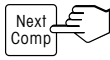



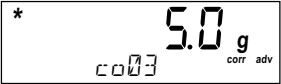
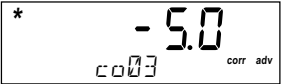

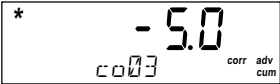
### Beispiel

Rezeptur besteht aus: 1. Komponente 125 g, 2. Komponente 20 g, 3. Komponente 5 g  
Kein Faktor, keine Toleranz angewählt. Die 2. Komponente wird falsch eingewogen (22.0 g statt 20.0 g)

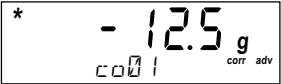
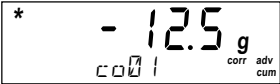
Aktion	"ADV ABS END"	"ADV CUM END"
Leeren Behälter auflegen und tarieren 		
Rezeptieren starten 		
Zielgewicht der 1. Komponente (125 g) ziffernweise eingeben 1. Ziffer  	 	 

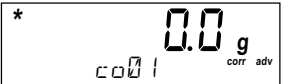
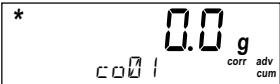

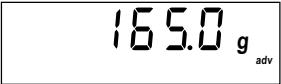
Aktion	"ADV ABS END"	"ADV CUM END"
<p>2. Ziffer</p>   <p>3. Ziffer</p>   <p>Eingegebenes Zielgewicht bestätigen</p> 	    	    
<p>1. Komponente einfüllen</p> 		
<p>Einwägung bestätigen</p> 		
<p>Zielgewicht der 2. Komponente 20 g (ABS)/145 g (CUM) ziffernweise eingeben und bestätigen (Vorgehen siehe 1. Komponente)</p> 	 	 
<p>2. Komponente einfüllen</p> 		 <p>2. Komponente wird um 2 g überfüllt</p>
<p>Einwägung bestätigen</p> 		

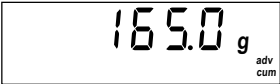
Aktion	"ADV ABS END"	"ADV CUM END"
<p>Zielgewicht der 3. Komponente 5 g (ABS)/150 g (CUM) ziffernweise eingeben und bestätigen (Vorgehen siehe 1. Komponente)</p> 	<p>* </p> <p>* </p>	<p>* </p> <p>* </p>
<p>3. Komponente einfüllen</p> 	<p>* </p> <p>Hinweis: Der Fehler beim Einwiegen der 2. Komponente wird beim Einwiegen der 3. Komponente bereits berücksichtigt. Bei Anzeige 0.0 wurden effektiv 5.5 g eingewogen.</p>	<p>* </p>
<p>Einwägung (letzte) bestätigen</p> 	<p>* </p> <p>Hinweis: Aufgrund des Fehlers beim Einwiegen der 2. Komponente muss die 1. Komponente um 12.5 g nachdosiert werden.</p>	<p>* </p>
<p>1. Komponente um 12.5 g nachdosieren</p> 	<p>* </p>	<p>* </p>
<p>Nachdosierung bestätigen</p> 	<p>* </p> <p>Der Rezeptvorgang wird beendet. Das Endgewicht der Mischung wird angezeigt.</p> <p></p>	<p>* </p> <p></p>

## 5.8 Rezeptieren mit "ADV ABS IMM" und "ADV CUM IMM"











### Ablauf



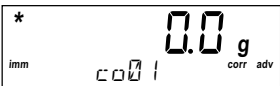
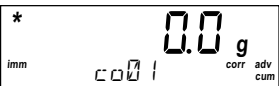



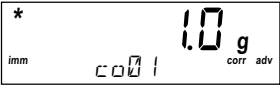



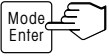





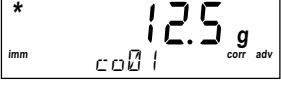
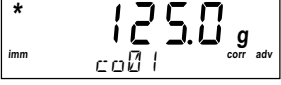



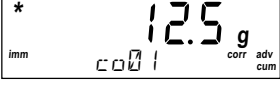
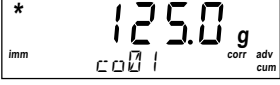

1. Leeren Behälter auflegen und tarieren.
2. Taste «Next Comp» drücken, um mit dem Rezeptieren zu beginnen.
3. Zielgewicht der angezeigten Komponente ziffernweise eingeben (mit Taste «+» bzw. «-» Ziffer setzen und gesetzte Ziffer durch kurzes Drücken der Taste «Enter» bestätigen). Eingegebenes Zielgewicht durch langes Drücken der Taste «Enter» bestätigen.
4. Komponente gegen Null einwiegen und Einwägung (auch bei Überfüllung) mit der Taste «Next Comp» bestätigen. Falls die Komponente überfüllt wurde, wird der Fehler beim Einfüllen nachfolgender Komponenten automatisch berücksichtigt.
5. Die Waage prüft unmittelbar nach jeder Komponente, ob die vorgängig eingewogenen Komponenten nachdosiert werden müssen. Falls ja: Angezeigte Komponenten nachdosieren und jeweils mit der Taste «Next Comp» bestätigen. Diesen Schritt wiederholen, bis alle Komponenten nachdosiert sind.
6. Schritte 3, 4 und 5 wiederholen, bis alle Komponenten eingewogen sind. Letzte Komponente mit der Taste «Last Comp» bestätigen.

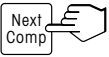



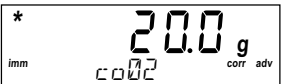
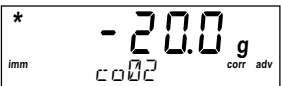

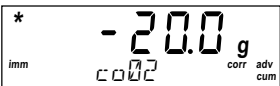

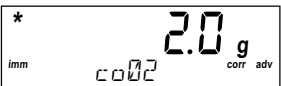
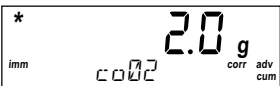

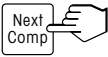
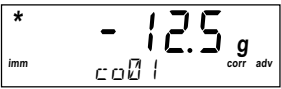
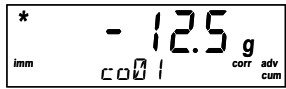

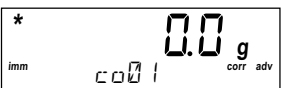
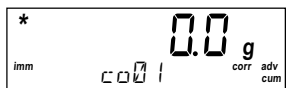
Nach Beendigung der Rezeptierung zeigt die Waage "done", danach das Endgewicht der Mischung.

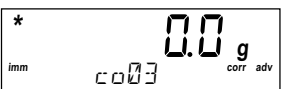
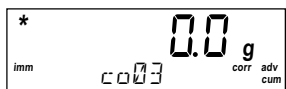
### Beispiel

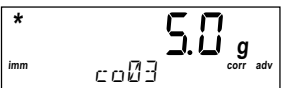
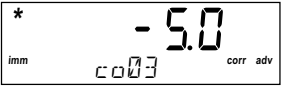
Rezeptur besteht aus: 1. Komponente 125 g, 2. Komponente 20 g, 3. Komponente 5 g  
Kein Faktor, keine Toleranz angewählt. Die 2. Komponente wird falsch eingewogen (22.0 g statt 20.0 g)

Aktion	"ADV ABS IMM"	"ADV CUM IMM"
Leeren Behälter auflegen und tarieren 		
Rezeptieren starten 		
Zielgewicht der 1. Komponente (125 g) ziffernweise eingeben 1. Ziffer  	 	 

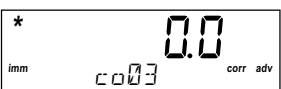
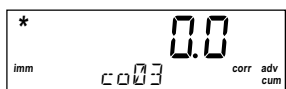
Aktion	"ADV ABS IMM"	"ADV CUM IMM"
<p>2. Ziffer </p> <p></p> <p>3. Ziffer </p> <p></p> <p>Eingegebenes Zielgewicht bestätigen </p>	<p></p> <p></p> <p></p> <p></p> <p></p>	<p></p> <p></p> <p></p> <p></p> <p></p>
<p>1. Komponente einfüllen </p>	<p></p>	<p></p>
<p>Einwägung bestätigen </p>	<p></p>	<p></p>
<p>Zielgewicht der 2. Komponente 20 g (ABS)/145 g (CUM) ziffernweise eingeben und bestätigen (Vorgehen siehe 1. Komponente) </p>	<p></p> <p></p>	<p></p> <p></p>
<p>2. Komponente einfüllen </p>	<p></p>	<p></p> <p>2. Komponente wird um 2 g überfüllt</p>

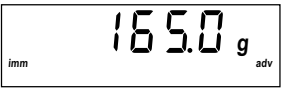
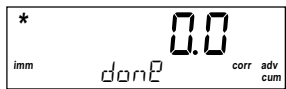
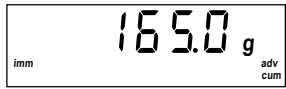
Aktion	"ADV ABS IMM"	"ADV CUM IMM"
Einwägung bestätigen 	 <p>Hinweis: Aufgrund des Fehlers beim Einwägen der 2. Komponente muss die 1. Komponente um 12.5g nachdosiert werden.</p>	
1. Komponente um 12.5 g nachdosieren 		
Nachdosierung bestätigen 		
Zielgewicht der 3. Komponente 5 g (ABS)/150 g (CUM) ziffernweise eingeben und bestätigen (Vorgehen siehe 1. Komponente) 	 	 
3. Komponente einfüllen 	 <p>Hinweis: Der Fehler beim Einwägen der 2. Komponente wird beim Einwägen der 3. Komponente bereits berücksichtigt. Bei Anzeige 0.0 wurden effektiv 5.5 g eingewogen.</p>	
Einwägung (letzte) bestätigen 	 <p>Der Rezeptvorgang wird beendet. Die effektive Endgewicht der Mischung wird angezeigt.</p> 	 

## 6 Der Mastermode

Im Mastermode lassen sich die Einstellungen der Waage ändern und Funktionen aktivieren.

### 6.1 Aufruf des Mastermodes

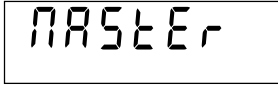
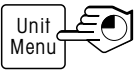

Im Wägemodus die Taste **«Menu»** solange gedrückt halten, bis die nebenstehende Anzeige erscheint.

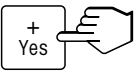

Innerhalb von 3 Sekunden die Taste **«Yes»** drücken (andernfalls kehrt die Waage wieder in den Wägemodus zurück). Anschließend erscheint der erste Menüblock des Mastermode.

### 6.2 Menü-Übersicht Mastermode

Bedienung des Mastermodes: Mit **«Yes»** Option bestätigen, mit **«No»** Option verwerfen.

Anzeige/Einstellungen	Funktion/Hinweise
CAL	Waage kalibrieren (siehe Kapitel 6.3, bei Eichwaagen nicht verfügbar)
SCALE	Waageneinstellungen
RESOLU	Auflösung wählen (bei Eichwaagen nicht verfügbar)
0.1	"Full Range" 0 ... 7100 g / 0.1 g (Werkseinstellung)
0.05	"Delta Range" 0 ... 999.95 g / 0.05 g, 1000 ... 7100 g / 0.1 g
Unit	Wägeeinheit wählen (bei Eichwaagen nicht verfügbar)
g	Gramm (Werkseinstellung)
oz	Unze
P	Parts (1 Part = 1/32 oz)
BLIGHT	Anzeigebeleuchtung ein-/ausschalten
On	eingeschaltet (Werkseinstellung)
OFF	ausgeschaltet
RESTART	Automatische Speicherfunktion ein-/ausschalten (bei Eichwaagen nicht verfügbar)
On	eingeschaltet
OFF	ausgeschaltet (Werkseinstellung)
VIBRATE	Vibrationsadapter wählen
NED	normale Wägegüter (Werkseinstellung)
HIGH	unruhige Umgebung
LOW	sehr ruhige Umgebung
PROCESS	Prozessadapter wählen
UNIVER	normale Wägegüter
DOSING	Dosieren, z.B. von flüssigen oder pulverförmigen Wägegütern (Werkseinstellung)
RESET	Rücksetzung aller SCALE-Einstellungen auf die Werkseinstellungen
Set On	Mit <b>«Yes»</b> auf Werkseinstellungen zurücksetzen, mit <b>«No»</b> verwerfen
End SC	"SCALE"-Block verlassen mit <b>«Yes»</b>

Anzeige/Einstellungen	Funktion/Hinweise
IFACE 1 / IFACE 2	Schnittstelle(n) konfigurieren
ModE	Betriebsart wählen
<b>d IALOG</b>	Kommunikation mit Computer (Werkseinstellung IFACE 1)
2nd d IS	Ansteuerung Zweitanzeige (Werkseinstellung IFACE 2)
PN	PM-Waagenmodus
Print	Kommunikation mit Drucker
CYCLE	Datenausdruck bei Gewichtsänderung
Protokoll	Protokoll wählen
<b>XONOFF</b>	Xon/Xoff-Protokoll (Werkseinstellung)
NO	kein Protokoll
PARITY	Bits und Parität wählen
7 EVEN	7 Datenbits mit gerader Parität
7 NO P	7 Datenbits ohne Parität
<b>8 NO P</b>	8 Datenbits ohne Parität (Werkseinstellung)
7 Odd	7 Datenbits mit ungerader Parität
BRUD	Datenübertragungsrate wählen
300	300, 600, 1200, 2400, 4800, <b>9600</b> (Werkseinstellung),
⋮	19200 und 38400
38400	
AutoMod	Automatikmodus
<b>AUTO S IF</b>	Schnittstelle sendet ununterbrochen Daten (Werkseinstellung IFACE 1)
NO	Automatikmodus ausgeschaltet (Werkseinstellung IFACE 2)
RESET	Rücksetzung der IFACE-Einstellung auf die Werkseinstellungen
Std On	Mit «Yes» auf Werkseinstellungen zurücksetzen, mit «No» verwerfen
End IF 1	“IFACE1”- bzw. “IFACE2”-Block verlassen mit «Yes»
List	Mit «Yes» Mastermode-Einstellungen ausdrucken
End	Mit «Yes» Mastermode verlassen. Rückfrage “StorE?” mit «Yes» bestätigen, um die Einstellungen zu speichern bzw. «No» um diese zu verwerfen.

### 6.3 Waage justieren/kalibrieren (bei Eichwaagen nicht verfügbar)

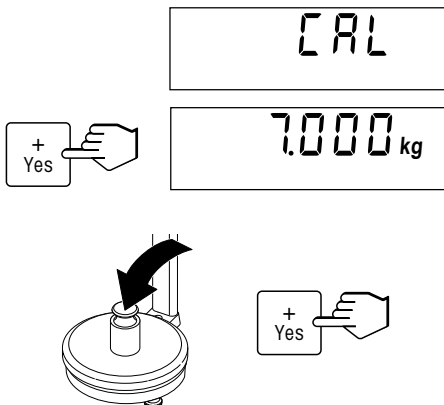

Mastermode aufrufen und “CAL” anwählen.

Waagschale entlasten und anschliessend die Taste «Yes» drücken, um den Kalibriervorgang zu starten.

Die Waage zeigt blinkend das Kalibriergewicht an (entsprechend der Nennlast der Waage). Mit der Taste «No» können auf Wunsch andere Kalibriergewichte gewählt werden.

Kalibriergewicht gemäss Anzeige auflegen und mit «Yes» bestätigen.

Hinweis: Die Kalibrierung kann jederzeit durch **langes Drücken der Taste «On/Off» abgebrochen** werden.

Warten bis die Kalibrierung erfolgreich abgeschlossen ist (wird in der Anzeige mit “done” bestätigt) und die Waage in den Wägemodus zurückkehrt.

## 7 Fehlermeldungen

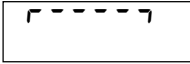

### Überlast

Waage entlasten oder Vorlast verringern.

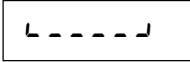

### Unterlast

Waagschale auflegen und sicherstellen, dass diese frei beweglich ist.



### Wägeresultat erreicht keine Stabilität

1. Für ruhige Umgebung sorgen
2. Sicherstellen, dass Waagschale frei beweglich ist
3. Einstellung des Vibrationsadapters ändern (Kap. 6.2)



### Funktion nicht ausgeführt

Die aufgerufene Funktion konnte nicht ausgeführt werden.

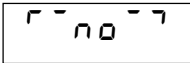

### Nullstellen nicht möglich (Überlast/Unterlast)

Sicherstellen, dass Nullstellen nicht bei Überlast bzw. Unterlast durchgeführt wird.

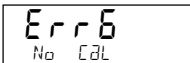
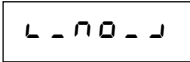

### Keine Kalibrierung/Justierung

Netzstecker aus- und wieder einstecken. Falls Meldung wieder erscheint, Waage kalibrieren/justieren (Kapitel 6.3). Falls auch dies nichts nützt, mit Händler oder Vertretung Kontakt aufnehmen.

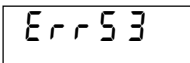

### EAROM Prüfsummenfehler

Netzstecker aus- und wieder einstecken. Falls Meldung wieder erscheint, mit Händler oder Vertretung Kontakt aufnehmen.

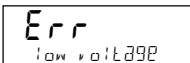

### Unterspannung

Ausgangsspannung des Netzadapters zu klein. Netzadapter durch solchen mit korrekter Ausgangsspannung ersetzen.



### Ablesbarkeit

Sollwerteingabe beim Rezeptieren mit zu feiner Auflösung. Wert der Ablesgenauigkeit der Waage anpassen (z.B. wenn Eingabe 15.01 g bei Ablesgenauigkeit 0.05 g).

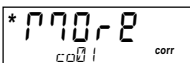

### Sollmenge noch nicht erreicht

Sollmenge der Komponente noch nicht erreicht. Nachdosieren bis Sollmenge erreicht ist.

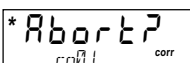

### Rezeptierung abgebrochen

Rezeptierung durch langes Drücken der Taste «Last Comp» abgebrochen.



## 8 Schnittstellen / Zubehör

### 8.1 Schnittstellendefinition

Standardmässig ist die Waage PS7 mit einer doppelt belegten RS232C-Schnittstelle und die PS7-X mit einer einfachen RS232C-Schnittstelle ausgerüstet. Die Schnittstelle(n) sind über die 9-polige Sub-D Buchse verfügbar. Die maximale Leitungslänge beträgt 15 m. Die Konfigurierung der Schnittstellen erfolgt im Mastermode (siehe Kapitel 6.2).

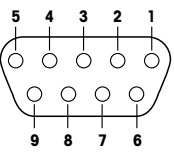
Eingebaute Schnittstelle(n) RS232C, 9-pin D-Sub, f		Belegung bei PS7	Belegung bei PS7-X	2 Schnittstellen bei Verwendung des Y-Kabels (Zubehör), nur bei PS7 COM1		COM2
<b>Belegung</b>	Pin 1	nc	nc	—	—	—
	Pin 2	TxD 1	TxD 1	TxD 1	TxD 2	TxD 2
	Pin 3	RxD 1	RxD 1	RxD 1	RxD 2	RxD 2
	Pin 4	nc	nc	—	—	—
	Pin 5	GND	GND	GND	GND	GND
	Pin 6	nc	nc	—	—	—
	Pin 7	RxD 2	nc	—	—	—
	Pin 8	TxD 2	nc	—	—	—
	Pin 9	VCC (5V, ≤50mA)	nc	—	—	VCC (5V, ≤50mA)

TxD: Daten senden

RxD: Daten empfangen

GND: Signallerde

VCC: Speisung (+5V, ≤50mA)

nc: not connected (nicht angeschlossen)

### 8.2 Zubehör

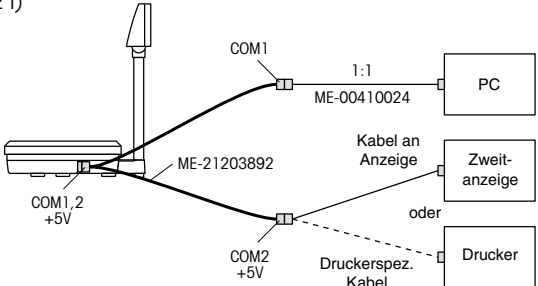
Zubehör	Art.-Nr.
Schutzhülle (Set à 5 Stk.)	21302841
Y-Kabel (9-pin D-Sub, m, COM1/2 f)  	21203892
RS232-Kabel für PC 1,8m (9-pin D-Sub, m/f, 1:1)	00410024

## 9 Technische Daten / Richtlinien und Prüfnormen

### 9.1 Technische Daten

Höchstlast	7100 g
Ablesbarkeit	Full Range: 0.1 g (0 ... 7100 g) Delta Range: 0.05 g (0 ... 999.95 g), 0.1 g (1000 ... 7100 g)
Einschwingzeit	ca. 1.0 Sekunden
Linearität	0.2 g
Stromversorgung	über Netzadapter/Speisegerät 13.5 VAC, 4 Watt
Wägeeinheiten	g, oz und P (1 Part = 1/32 oz)
Anzeige	LCD (Flüssigkristallanzeige), hinterleuchtet
Umgebungsbedingungen	Temperaturbereich: +10 ... +30°C Relative Luftfeuchtigkeit: 20 ... 80% rF (nicht betauend)
Gewicht netto/brutto	3.4 kg / 4.5 kg
Überspannungskategorie:	II
Verschmutzungsgrad:	2

### Abmessungen

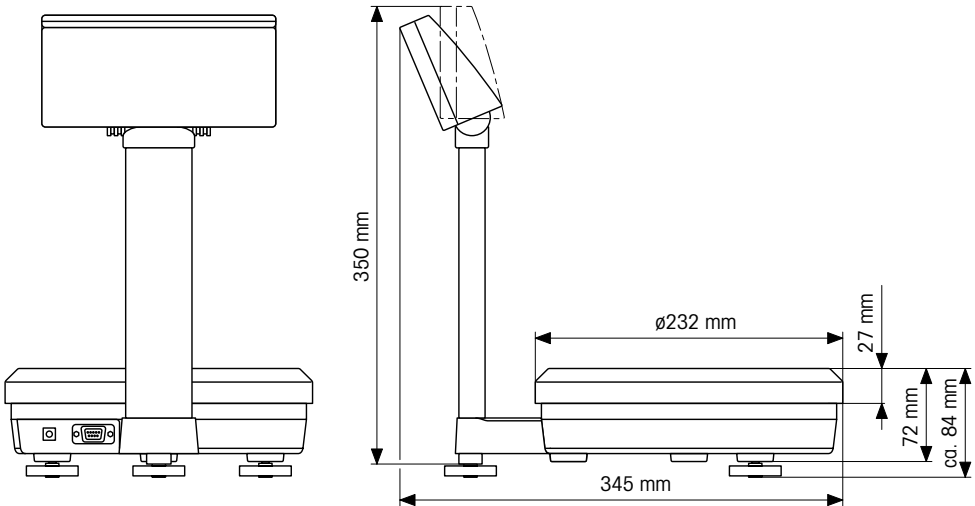







## 9.2 Richtlinien und Prüfnormen

### Waagenlinie PS7

Wir erklären in alleiniger Verantwortung, dass das Produkt, auf das sich diese Erklärung bezieht, mit den nachstehenden EG-Richtlinien übereinstimmt.

Hinweise: Für geeichte/eichpflichtige Waagen liegt eine EG-Bauartzulassung vor. Das Jahr der ersten Eichung ist neben dem CE Zeichen aufgeführt. Solche Waagen sind ab Werk geeicht und tragen die Kennzeichnung «M» auf dem Gerät selbst und auf der Verpackung. Erscheint der Buchstabe M auf vollem Grund, darf die Waage sofort in Betrieb genommen werden. Ist der Grund geteilt und schraffiert, muss die Waage am Verwendungsort durch den zertifizierten METTLER TOLEDO Service ortsgeeicht werden. Sofern gemäss den nationalen Vorschriften in den einzelnen Staaten die Gültigkeitsdauer der Eichung beschränkt ist, ist der Betreiber einer solchen Waage für die rechtzeitige Nacheichung selbst verantwortlich.

Kennzeichen	EG-Richtlinie	geprüft nach Norm
 	73/23EEC Niederspannung	EN61010-1  CAN/CSA-22.2 No. 1010.1-92
 	89/336EEC EMV	EN61326-1 Emission Kl. B EN61000-3-2 Oberschwingungen EN61000-3-3 Spannungsschwankungen EN61326-1 Immunität (Industriebereich) AS/NZS2064.1/2, AS/NZS3548 AS/NZS4251.1, AS/NZS4252.1
 [year] <sup>1)</sup>  [code]	90/384EEC <sup>1)</sup> Nicht selbsttätige Waagen	EN45501 <sup>1)</sup> Metrologische Aspekte

<sup>1)</sup> gilt nur für geeichte Waagen

Mettler-Toledo GmbH  
Industrial BA IND-N  
Nänikon, Mai 2001

Johannes Schmid  
General Manager  
Standard Industrial

Marlise Ackermann  
Project Manager  
Product Area General Weighing

### USA

*This equipment has been tested and found to comply with the limits for a Class A digital device, pursuant to both Part 15 of the FCC Rules and the radio interference regulations of the Canadian Department of Communications. These limits are designed to provide reasonable protection against harmful interference when the equipment is operated in a commercial environment. This equipment generates, uses and can radiate radio frequency energy and, if not installed and used in accordance with the instruction manual, may cause harmful interference to radio communications. Operation of this equipment in a residential area is likely to cause harmful interference, in which case the user will be required to correct the interference at his own expense.*

### Canada







*ICES-001 Notice for Industrial, Scientific and Medical Radio Frequency Generators: This ISM apparatus meets all requirements of the Canadian Interference-Causing Equipment Regulations. Please note that this requirement is only for generators which operate at over 10 kHz.*

*Avis de l'ICES-001, générateurs de radiofréquences dans le domaine industriel, scientifique et médical: Cet appareil ISM (industriel, scientifique et médical) satisfait à toutes les exigences définies par la réglementation canadienne en matière d'équipements générant des perturbations radioélectriques. Veuillez noter qu'il s'agit d'une exigence concernant uniquement les générateurs fonctionnant au-delà de 10 kHz.*

**Waagenlinie PS7-X**

Wir erklären in alleiniger Verantwortung, dass das Produkt, auf das sich diese Erklärung bezieht, mit den nachstehenden EG-Richtlinien übereinstimmt.

Hinweise: Für geeichte/eichpflichtige Waagen liegt eine EG-Bauartzulassung vor. Das Jahr der ersten Eichung ist neben dem CE Zeichen aufgeführt. Solche Waagen sind ab Werk geeicht und tragen die Kennzeichnung «M» auf dem Gerät selbst und auf der Verpackung. Erscheint der Buchstabe M auf vollem Grund, darf die Waage sofort in Betrieb genommen werden. Ist der Grund geteilt und schraffiert, muss die Waage am Verwendungsort durch den zertifizierten METTLER TOLEDO Service ortsgerecht werden. Sofern gemäss den nationalen Vorschriften in den einzelnen Staaten die Gültigkeitsdauer der Eichung beschränkt ist, ist der Betreiber einer solchen Waage für die rechtzeitige Nacheichung selbst verantwortlich.

Kennzeichen	EG-Richtlinie	geprüft nach Norm
  	94/9/EEC (ATEX)	EN50014, EN50020  FMRC 3600, 3610, 3810  CSA-C22.2 No. 157-92 CSA-C22.2 No. 142-M 1987
	73/23EEC Niederspannung	EN60950-1
 	89/336EEC EMV	EN61326-1 Emission Kl. B EN61000-3-2 Oberschwingungen EN61000-3-3 Spannungsschwankungen EN61326-1 Immunität (Industriebereich)  AS/NZS2064.1/2, AS/NZS3548 AS/NZS4251.1, AS/NZS4252.1

Mettler-Toledo GmbH  
Industrial BA IND-N  
Nänikon, Mai 2001

Johannes Schmid  
General Manager  
Standard Industrial

Marlise Ackermann  
Project Manager  
Product Area General Weighing

**USA**

*This equipment has been tested and found to comply with the limits for a Class A digital device, pursuant to both Part 15 of the FCC Rules and the radio interference regulations of the Canadian Department of Communications. These limits are designed to provide reasonable protection against harmful interference when the equipment is operated in a commercial environment. This equipment generates, uses and can radiate radio frequency energy and, if not installed and used in accordance with the instruction manual, may cause harmful interference to radio communications. Operation of this equipment in a residential area is likely to cause harmful interference, in which case the user will be required to correct the interference at his own expense.*

**Canada**

*ICES-001 Notice for Industrial, Scientific and Medical Radio Frequency Generators: This ISM apparatus meets all requirements of the Canadian Interference-Causing Equipment Regulations. Please note that this requirement is only for generators which operate at over 10 kHz.*

*Avis de l'ICES-001, générateurs de radiofréquences dans le domaine industriel, scientifique et médical: Cet appareil ISM (industriel, scientifique et médical) satisfait à toutes les exigences définies par la réglementation canadienne en matière d'équipements générant des perturbations radioélectriques. Veuillez noter qu'il s'agit d'une exigence concernant uniquement les générateurs fonctionnant au-delà de 10 kHz.*

# 1 Introduction

## 1.1 Généralités

Nous vous remercions d'avoir opté pour la **balance pour le mélange des couleurs PS7 ou pour sa variante pour atmosphère explosible PS7-X**. La balance PS7/PS7-X permet de doser des composants avec un rapport de mélange préalablement défini. La balance dispose de différents modes de correction, pour compenser les composants éventuellement incorrectement dosés. Via l'interface RS232 intégrée, la balance peut être raccordée à une imprimante ou être reliée à un ordinateur ou à un afficheur auxiliaire.

Nous vous demandons de lire attentivement le présent mode d'emploi et de respecter les instructions!

## 1.2 Sécurité et environnement



- **La balance PS7 ne doit pas être utilisée en atmosphère explosible** (comportant des mélanges explosibles de gaz, de vapeurs, de brouillards et de poussières).

Pour les **zones à risques d'explosion**, il faut utiliser une balance du type **PS7-X**. Ces balances doivent être **obligatoirement** raccordées **via l'unité d'alimentation certifiée** METTLER TOLEDO. Tenez absolument compte des remarques données dans la notice d'installation relative à l'unité d'alimentation. L'utilisation d'une housse de protection dans des zones à risques d'explosion n'est permise, en raison du danger de charge électrostatique, que si elle est constituée d'un matériau neutre sur le plan statique.

- Ne raccorder la balance au secteur **qu'avec l'adaptateur secteur fourni (PS7)** ou avec **l'unité d'alimentation (PS7-X)**. S'assurer que la valeur de tension imprimée sur l'appareil concorde avec la tension secteur locale. Contrôler régulièrement le câble de l'adaptateur secteur/de l'unité d'alimentation. Si les câbles ou si l'adaptateur secteur/l'unité d'alimentation sont endommagés, il ne faut pas continuer à utiliser la balance.
- N'utiliser que les accessoires et les périphériques recommandés.
- Manipuler la balance avec précaution, elle est un instrument de précision. Des coups sur le plateau de la balance et la pose de surcharges importantes sur celui-ci endommagent la balance.
- **Avant de commencer des opérations de nettoyage, couper la balance du secteur!**

Nettoyage: Utiliser un chiffon humide (pas d'acides, de détergents ou de solvants). En cas d'encrassement important, retirer le plateau de la balance, la housse de protection (si existante) et les pieds réglables (uniquement sur les balances vérifiées) et les nettoyer séparément. Respecter les prescriptions internes à l'entreprise et spécifiques au secteur d'activité concernant les intervalles de nettoyage et les produits de nettoyage autorisés.

- Pour l'élimination de la balance, tenir compte de la législation relative à la protection de l'environnement.

## 1.3 Remarques sur les modèles vérifiés

Les fonctions indiquées ci-dessous sont désactivées sur les modèles vérifiés :

- formulation (pesée avec coefficient multiplicateur et formulation avec correction)
- modification de l'unité de pesée (unité de pesée définie par défaut sur "g" pour les balances vérifiées)
- étalonnage (les modèles vérifiés doivent être ajustés/étalonnés par une agence de maintenance METTLER TOLEDO agréée)

## 2 Mise en service

### 2.1 Installation de la balance et mise de niveau

L'emplacement approprié contribue de manière décisive à la précision des résultats de pesée!

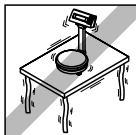

Choisissez un support fixe, dépourvu de vibrations et le plus horizontal possible.



Ne fermez jamais à l'aide d'un marteau les pots de peinture se trouvant encore sur le plateau de la balance.



Évitez les fluctuations importantes de température et les rayons directs du soleil. Tenez compte des conditions ambiantes.

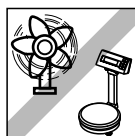

Évitez les courants d'air (p. ex. de ventilateurs ou d'installations de climatisation).

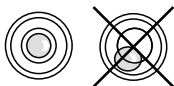

**Uniquement balance vérifiée:** Mettre la balance de niveau en tournant les pieds réglables. La bulle d'air doit se trouver dans le cercle intérieur.

Remarque: Les balances vérifiées doivent être réglées sur le lieu d'utilisation par un service de maintenance METTLER TOLEDO autorisé.

#### Changement d'emplacement, avec éloignement important

Nous vous recommandons d'étalonner la balance lors de la première mise en service (voir chapitre 6.3). La vérification des balances vérifiées doit être effectuée sur le lieu d'utilisation en respectant les prescriptions de métrologie légale.

Français

### 2.2 Raccordement de l'alimentation électrique

**PS7-X pour des zones à risques d'explosion:** Les balances du type PS7-X pour zones à risques d'explosion ne doivent être raccordées que par l'intermédiaire d'une unité d'alimentation certifiée. Veuillez donc impérativement tenir compte des indications mentionnées dans la notice d'installation séparée de l'unité d'alimentation.

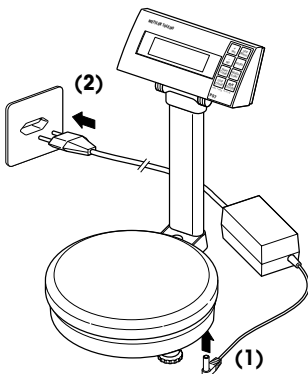

**Attention!** Avant le raccordement de l'adaptateur secteur, contrôler si la valeur de tension imprimée sur l'appareil concorde avec la tension secteur locale.

**Important!** Raccorder d'abord l'adaptateur secteur à la prise située sous la face inférieure de la balance (1). Ensuite seulement enficher le connecteur mâle de l'adaptateur secteur dans la prise secteur (2).

Après le raccordement, la balance effectue un test d'affichage au cours duquel tous les segments et ensuite la version logicielle sont brièvement affichés. Dès que l'affichage du zéro apparaît, la balance est prête à fonctionner.

### 3 Fonctions des touches

Touche	Fonction lors d'une	
	Pression brève	Pression prolongée
<b>O/T</b> On/Off	Tarer la balance **	Mettre en marche ou arrêter la balance **
Factor	Sélectionner le facteur de conversion pour doser une quantité plus petite ou plus grande d'une formule	Réinitialiser le facteur de conversion à "1" (pesage sans facteur)
Unit Menu	Modifier l'unité de poids	Accéder au Master Mode ** (voir chapitre 6.1)
Next Comp	Confirmer le poids cible d'un composant dosé et poursuivre avec le prochain composant	—
Last Comp	Confirmer le poids cible du dernier composant dosé d'une formule	Annuler le processus de formulation
Mode Enter	Sélectionner la méthode de formulation ou la tolérance <b>Mode formulation avancée</b> Saisir le prochain chiffre du poids cible	Confirmer la méthode de formulation ou la tolérance sélectionnée <b>Mode formulation avancée</b> Confirmer le poids cible entré
+ Yes	Fonction dépendante du mode de fonctionnement actuellement sélectionné <b>Master Mode **</b> Confirmer le paramétrage actuel <b>Mode formulation standard</b> Augmenter la val. de cons. du composant <b>Mode formulation avancée</b> Augmenter la val. de cons. du composant	<b>Master Mode</b> — <b>Mode formulation standard</b> Augmenter la val. de cons. du compos. de 1.0 <b>Mode formulation avancée</b> —
- No	Fonction dépendante du mode de fonctionnement actuellement sélectionné <b>Master Mode **</b> Rejeter le paramétrage actuel <b>Mode formulation standard</b> Réduire la valeur de cons. du composant  <b>Mode formulation avancée</b> Réduire la valeur de cons. du composant	<b>Master Mode</b> — <b>Mode formulation standard</b> Réduire la valeur de consigne du composant de 1.0 (si la touche est maintenue pressée, la valeur continue à être réduite automatiquement) <b>Mode formulation avancée</b> Revenir au dernier chiffre

\*\* Seules ces touches sont actives sur les balances vérifiées

## 4 Pesage

### 4.1 Mise en marche/arrêt et sélection de l'unité de poids

#### Mise en marche/arrêt



Par une **pression prolongée** de la touche «**O/T**», vous allumez ou éteignez la balance. Après la mise en marche, la balance effectue un test d'affichage. Dès que l'affichage du poids apparaît, la balance est prête à peser et est automatiquement mise à zéro.

#### Sélection de l'unité de poids (non disponible pour les balances vérifiées)



Par une **pression brève** de la touche «**Unit**», l'unité de poids peut être commutée entre "g" (gramme), "oz" (once) et "P" (Parts).

### 4.2 Pesage simple

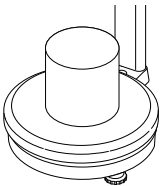

Placer le récipient de pesage sur le plateau. Pour tarer, presser brièvement la touche «**O/T**». L'affichage du zéro apparaît.

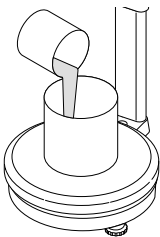

Verser la quantité de produit à peser voulue.

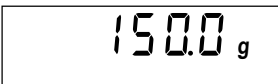

Attendre que le détecteur de stabilité (symbole annulaire dans l'affichage) s'éteigne et lire le résultat de pesée.



## 5 Formulation

Remarque: **les fonctions de formulation sont désactivées sur les balances vérifiées** (pesée avec coefficient multiplicateur, formulation avec correction).

### 5.1 Sélection du facteur

Pour doser une quantité plus importante ou plus faible d'une formule prédéfinie, un facteur (multiplicateur) peut être sélectionné.

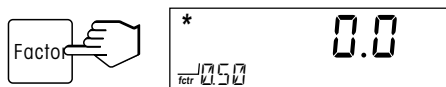

Par une **pression brève** de la touche «**Factor**», vous activez la pesée avec facteur.

Dans l'affichage apparaît en bas à gauche le facteur utilisé lors de la dernière pesée avec facteur (p. ex. 0.50).

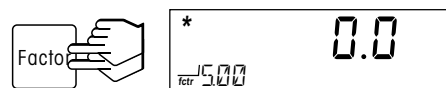

Pressez ensuite **plusieurs fois brièvement** la touche «**Factor**», jusqu'à ce que le facteur voulu (0.20 ... 5.00) soit affiché.

Lors de la pesée qui suit, un composant est dosé vers le poids cible (p. ex. 1000 g) selon la formule. En fonction du facteur sélectionné, une quantité plus importante ou plus faible, proportionnelle au facteur, sera effectivement dosée.

**Exemple 1 :** Poids selon formule 1000 g, facteur sélectionné 0.50 (pour la moitié de la quantité). Affichage: 1000, dosage effectif: 500 g

**Exemple 2 :** Poids selon formule 1000 g, facteur sélectionné 3.00 (pour le triple de la quantité). Affichage: 1000, dosage effectif: 3000 g



**Désactivation de la pesée avec facteur :** Vous désactivez la pesée avec facteur par une **pression prolongée** de la touche «**Factor**».

L'affichage du facteur disparaît et le facteur est ramené à 1.

## 5.2 Les diverses méthodes de formulation

La PS7 propose diverses méthodes de formulation. Chaque méthode de formulation comprend:

- le **mode formulation**:
  - **"STJ" Formulation standard**: Dans ce mode, la quantité voulue d'un composant est dosée et validée. En cas de dosage erroné, le poids cible effectif du composant incorrectement dosé doit être saisi avant le dosage du prochain composant. L'erreur sera automatiquement prise en compte lors du dosage des composants qui suivent.
  - **"RJV" Formulation avancée**: Dans ce mode, le poids cible d'un composant est d'abord saisi. Ensuite, le composant est dosé et validé. Une éventuelle erreur de dosage est automatiquement prise en compte lors du rajout des composants qui suivent.
- le **type d'affichage**:
  - **"ABS" Affichage absolu**: Affichage du poids absolu d'un composant.
  - **"CUM" Affichage cumulatif**: Affichage du poids cumulé.
- le **mode correction**:
  - **Correction "IMM"**: Correction immédiate après chaque composant incorrectement dosé
  - **Correction "END"**: Correction à la fin de la formulation

Les **8 méthodes de formulation différentes** obtenues par combinaison:

Méthode de formulation	Mode formulation		Type d'affichage		Mode correction	
	Standard	Avancé	Absolu	Cumulatif	immédiat	à la fin
STJ ABS END → Chap. 5.5	X		X			X
STJ CUM END → Chap. 5.5	X			X		X
STJ ABS IMM → Chap. 5.6	X		X		X	
STJ CUM IMM → Chap. 5.6	X			X	X	
RJV ABS END → Chap. 5.7		X	X			X
RJV CUM END → Chap. 5.7		X		X		X
RJV ABS IMM → Chap. 5.8		X	X		X	
RJV CUM IMM → Chap. 5.8		X		X	X	

### 5.3 Sélection de la méthode de formulation

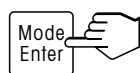

Corr P  
STD ABS END

Presser brièvement la touche «**Mode**». La dernière méthode de formulation sélectionnée apparaît sur l'affichage (d'origine: "STD ABS END").



Corr P  
ADV ABS END

Par une **pression brève** répétée de la touche «**Mode**», sélectionner la méthode de formulation voulue (p. ex. "ADV ABS END").



tol P  
1.5 % tol adv

Confirmer la méthode de formulation sélectionnée par une **pression prolongée** de la touche «**Mode**».

Si vous avez sélectionné une méthode de formulation avancée ("ADV ..."), apparaît l'affichage pour la sélection de la tolérance dont le dépassement doit entraîner la correction des divers composants.



tol P  
1.5 % tol adv

Par une **pression brève** et répétée de la touche «**Mode**», sélectionner la tolérance plus/moins en % (no, 0.5 ... 15.0) voulue.

Remarque: "no" signifie une tolérance de zéro.



Confirmer la tolérance sélectionnée (p. ex. 1.5 %) par une **pression prolongée** de la touche «**Mode**». La balance est ensuite prête pour la formulation.

**Remarque:** La méthode de formulation sélectionnée reste active jusqu'à ce qu'une autre méthode soit sélectionnée.

### 5.4 Divers



#### Annulation de la formulation

Une formulation peut être annulée à tout moment par une **pression prolongée** de la touche «**Last Comp**».



#### Impression du compte rendu de formulation

Si votre balance est reliée à une imprimante, le compte rendu de formulation correspondant peut être imprimé après la fin d'une formulation par une **pression prolongée** de la touche «**Last Comp**».

```
Mode :STD ABS END
Components:
co01
  target: 100.0 g
  true : 110.0 g
co02
  target: 20.0 g
  true : 22.0 g
co03
  target: 5.0 g
  true : 5.5 g
```

## 5.5 Formulation avec "STD ABS END" et "STD CUM END"

### Déroulement

- Placer le récipient vide sur le plateau et effectuer le tarage.
  - Doser le composant vers le poids cible et confirmer le dosage correct avec la touche «Next Comp».
 

Si le composant a été surdosé, saisir d'abord le poids de consigne du composant avec la touche «←» et confirmer avec la touche «Next Comp».









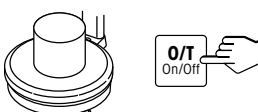

Remarque: L'erreur sera automatiquement prise en compte lors du dosage des composants qui suivent.

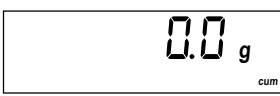

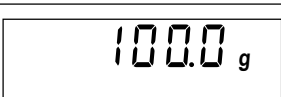
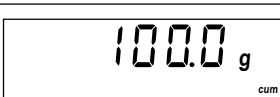

Répéter cette étape, jusqu'à ce que tous les composants soient dosés. Confirmer le dernier composant avec la touche «Last Comp».
  - La balance contrôle si des composants doivent être redosés. Si oui: Redoser les composants affichés et confirmer à chaque fois avec la touche «Next Comp».
 

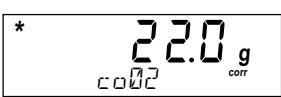
Répéter cette étape, jusqu'à ce que tous les composants soient redosés.
- Lorsque la formulation est clôturée, la balance affiche "done", puis le poids final du mélange.

### Exemple

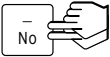
Formulation constituée de: 1<sup>er</sup> composant 100 g, 2<sup>e</sup> composant 20 g, 3<sup>e</sup> composant 5 g  
Aucun facteur sélectionné. Le 2<sup>e</sup> composant est incorrectement dosé (22.0 g au lieu de 20.0 g)

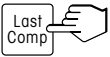
Action	"STD ABS END"	"STD CUM END"
Placer le récipient vide et tarer 		
Verser le 1 <sup>er</sup> composant (valeur de consigne 100 g) 		
Confirmer le 1 <sup>er</sup> composant 		
Verser le 2 <sup>e</sup> composant (valeur de consigne 20 g) 		
	Le 2 <sup>e</sup> composant est surdosé de 2 g	

Action	"STD ABS END"	"STD CUM END"
Saisir la valeur de consigne pour le 2 <sup>e</sup> composant 20 g (ABS)/120 g (CUM) 	* 20.0 g c002 corr	* 120.0 g c002 corr cum
Confirmer la valeur de consigne 	* 0.0 c003 corr	* 120.0 c003 corr cum
Verser le 3 <sup>e</sup> composant (valeur de consigne 5 g) 	* 5.0 c003 corr	* 125.0 c003 corr cum
Confirmer le 3 <sup>e</sup> (dernier) composant 	* - 10.0 g c001 corr	* - 10.0 g c001 corr cum
Redoser le 1 <sup>er</sup> composant de 10 g 	* 0.0 g c001 corr	* 0.0 g c001 corr cum
Confirmer la correction 	* 0.0 g done corr	* 0.0 g done corr cum
	137.5 g	137.5 g

Remarque: L'erreur commise lors du dosage du 2<sup>e</sup> composant est déjà prise en compte lors du dosage du 3<sup>e</sup> composant, c-à-d, pour le 3<sup>e</sup> composant sont effectivement dosés 5.5 g (au lieu de 5.0 g). Ce surdosage s'effectue cependant en tâche de fond, c-à-d, sur l'affichage apparaît la valeur de consigne selon la formule (5.0 ou 125.0).

Remarque: Suite à l'erreur commise lors du dosage du 2<sup>e</sup> composant, le 1<sup>er</sup> composant doit être redosé de 10 g.

Le processus de formulation est clôturé. Le poids final du mélange est affiché.

## 5.6 Formulation avec "STD ABS IMM" et "STD CUM IMM"









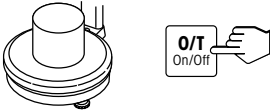
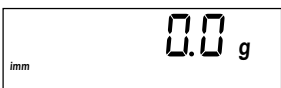
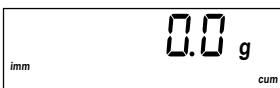

### Déroulement





1. Placer le récipient vide sur le plateau et effectuer le tarage.
2. Doser le composant vers le poids cible et confirmer le dosage correct avec la touche «Next Comp». Si le composant a été surdosé, saisir d'abord le poids de consigne du composant avec la touche «←» et confirmer avec la touche «Next Comp». L'erreur sera automatiquement prise en compte lors du versement des composants qui suivent.
3. Immédiatement après chaque composant, la balance contrôle si les composants préalablement dosés doivent être redosés. Si oui: Redoser les composants affichés et confirmer à chaque fois avec la touche «Next Comp». Répéter cette étape, jusqu'à ce que tous les composants soient redosés.
4. Répéter les étapes 2 et 3, jusqu'à ce que tous les composants soient dosés. Confirmer le dernier composant avec la touche «Last Comp».

Lorsque la formulation est clôturée, la balance affiche "done", puis le poids final du mélange.

### Exemple

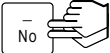
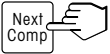
Formulation constituée de: 1<sup>er</sup> composant 100 g, 2<sup>e</sup> composant 20 g, 3<sup>e</sup> composant 5 g  
Aucun facteur sélectionné. Le 2<sup>e</sup> composant est incorrectement dosé (22.0 g au lieu de 20.0 g)

Action	"STD ABS IMM"	"STD CUM IMM"
Placer le récipient vide et tarer 		
Verser le 1 <sup>er</sup> composant (valeur de consigne 100 g) 		
Confirmer le 1 <sup>er</sup> composant 		
Verser le 2 <sup>e</sup> composant (valeur de consigne 20 g) 		
	Le 2 <sup>e</sup> composant est surdosé de 2 g	

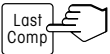
Action	"STD ABS IMM"	"STD CUM IMM"
Saisir la valeur de consigne pour le 2 <sup>e</sup> composant 20 g (ABS)/120 g CUM 	* imm 20.0 g corr c002	* imm 120.0 g corr cum c002
Confirmer la valeur de consigne 	* imm - 10.0 g corr c001	* imm - 10.0 g corr cum c001
Redoser le 1 <sup>er</sup> composant de 10 g 	* imm 0.0 g corr c001	* imm 0.0 g corr cum c001
Confirmer la correction 	* imm 0.0 g corr c003	* imm 120.0 g corr cum c003
Verser le 3 <sup>e</sup> composant (valeur de consigne 5 g) 	* imm 5.0 g corr c003	* imm 125.0 g corr cum c003
Confirmer le 3 <sup>e</sup> (dernier) composant 	* imm 0.0 g corr done	* imm 125.0 g corr cum done
	imm 137.5 g	imm 137.5 g cum

Remarque: Suite à l'erreur commise lors du dosage du 2<sup>e</sup> composant, le 1<sup>er</sup> composant doit être redosé de 10 g.

Remarque: L'erreur commise lors du dosage du 2<sup>e</sup> composant est déjà prise en compte lors du dosage du 3<sup>e</sup> composant, c-à-d, pour le 3<sup>e</sup> composant sont effectivement dosés 5.5 g (au lieu de 5.0 g). Ce surdosage s'effectue cependant en tâche de fond, c-à-d, sur l'affichage apparaît la valeur de consigne selon la formule (5.0 ou 125.0).

Le processus de formulation est clôturé. Le poids final du mélange est affiché.

## 5.7 Formulation avec "ADV ABS END" et "ADV CUM END"

### Déroulement







1. Placer le récipient vide sur le plateau et effectuer le tarage.
2. Presser la touche **«Next Comp»** pour commencer la formulation.
3. Saisir chiffre par chiffre le poids cible du composant affiché (sélectionner le chiffre avec la touche **«+»** ou **«-»** et confirmer les chiffres sélectionnés par une pression brève de la touche **«Enter»**). Confirmer le poids cible saisi par une pression prolongée de la touche **«Enter»**.
4. Doser le composant jusqu'à ce que l'affichage indique zéro et confirmer le dosage (même en cas de surdosage) avec la touche **«Next Comp»**. Si le composant a été surdosé, l'erreur sera automatiquement prise en considération lors du versement des composants qui suivent.
5. Répéter les étapes 3 et 4, jusqu'à ce que tous les composants soient dosés. Confirmer le dernier composant avec la touche **«Last Comp»**.
6. La balance contrôle si certains composants doivent être redosés. Si oui: Redoser les composants affichés et confirmer à chaque fois avec la touche **«Next Comp»**.  
Répéter cette étape, jusqu'à ce que tous les composants soient redosés.

Lorsque la formulation est clôturée, la balance affiche "done", puis le poids final du mélange.

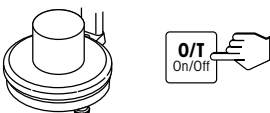
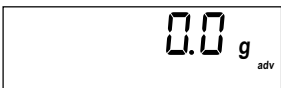
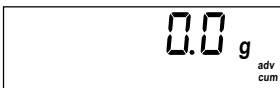



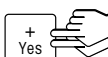

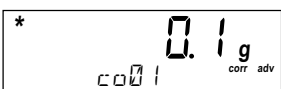
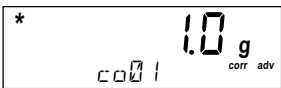
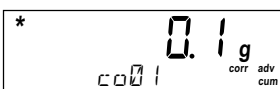
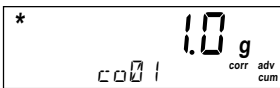

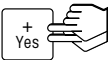

### Exemple



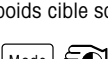
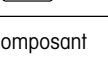





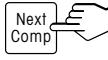

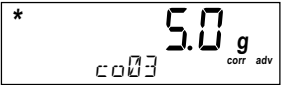
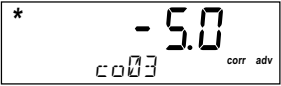

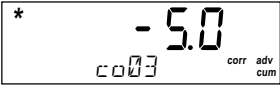

Formulation constituée de: 1<sup>er</sup> composant 125 g, 2<sup>e</sup> composant 20 g, 3<sup>e</sup> composant 5 g

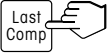
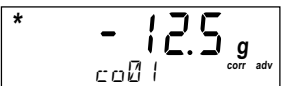
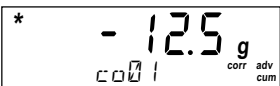
Aucun facteur, aucune tolérance sélectionnés. Le 2<sup>e</sup> composant est incorrectement dosé (22.0 g au lieu de 20.0 g)

Action	"ADV ABS END"	"ADV CUM END"
Placer le récipient vide et tarer 		
Démarrer la formulation 		
Saisir chiffre par chiffre le poids cible du 1 <sup>er</sup> composant (125 g) 1 <sup>er</sup> chiffre  	 	 

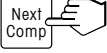

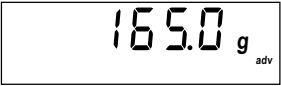
Action	"ADV ABS END"	"ADV CUM END"
2 <sup>e</sup> chiffre  	* 1.2 g corr adv c 0 0 1	* 1.2 g corr adv cum c 0 0 1
3 <sup>e</sup> chiffre  	* 12.0 g corr adv c 0 0 1	* 12.0 g corr adv cum c 0 0 1
3 <sup>e</sup> chiffre  	* 12.5 g corr adv c 0 0 1	* 12.5 g corr adv cum c 0 0 1
Confirmer le poids cible saisi 	* - 125.0 g corr adv c 0 0 1	* - 125.0 g corr adv cum c 0 0 1
Verser le 1 <sup>er</sup> composant 	* 0.0 g corr adv c 0 0 1	* 0.0 g corr adv cum c 0 0 1
Confirmer le dosage 	* 0.0 g corr adv c 0 0 2	* 0.0 g corr adv cum c 0 0 2
Saisir chiffre par chiffre le poids cible du 2 <sup>e</sup> composant 20 g (ABS)/145 g (CUM) et confirmer (pour la procédure, voir 1 <sup>er</sup> composant) 	* 20.0 g corr adv c 0 0 2	* 145.0 g corr adv cum c 0 0 2
Verser le 2 <sup>e</sup> composant 	* 2.0 g corr adv c 0 0 2	* 2.0 g corr adv cum c 0 0 2
	Le 2 <sup>e</sup> composant est surdosé de 2 g	
Confirmer le dosage 	* 0.0 g corr adv c 0 0 3	* 0.0 g corr adv cum c 0 0 3

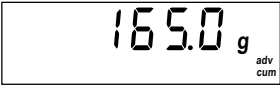
Action	"ADV ABS END"	"ADV CUM END"
<p>Saisir chiffre par chiffre le poids cible du 3<sup>e</sup> composant 5 g (ABS)/150 g (CUM) et confirmer (pour la procédure, voir 1<sup>er</sup> composant)</p> 	<p>* </p> <p>* </p>	<p>* </p> <p>* </p>
<p>Verser le 3<sup>e</sup> composant</p> 	<p>* </p> <p>Remarque: L'erreur commise lors du dosage du 2<sup>e</sup> composant est déjà prise en compte lors du dosage du 3<sup>e</sup> composant. 5.5 g ont été effectivement dosés, alors que la balance affichait 0.0.</p>	<p>* </p>
<p>Confirmer le (dernier) dosage</p> 	<p>* </p> <p>Remarque: Suite à l'erreur commise lors du dosage du 2<sup>e</sup> composant, le 1<sup>er</sup> composant doit être redosé de 12.5 g.</p>	<p>* </p>
<p>Redoser le 1<sup>er</sup> composant de 12.5 g</p> 	<p>* </p>	<p>* </p>
<p>Confirmer le redosage</p> 	<p>* </p> <p>Le processus de formulation est clôturé. Le poids final du mélange est affiché.</p> 	<p>* </p> 

## 5.8 Formulation avec "ADV ABS IMM" et "ADV CUM IMM"

### Déroulement









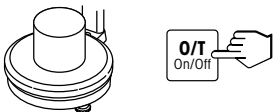

1. Placer le récipient vide sur le plateau et effectuer le tarage.
2. Presser la touche «**Next Comp**» pour commencer la formulation.
3. Saisir chiffre par chiffre le poids cible du composant affiché (sélectionner le chiffre avec la touche «**+**» ou «**-**» et confirmer les chiffres sélectionnés par une pression brève de la touche «**Enter**»). Confirmer le poids cible saisi par une pression prolongée de la touche «**Enter**».
4. Doser le composant jusqu'à ce que l'affichage indique zéro et confirmer le dosage (même en cas de surdosage) avec la touche «**Next Comp**». Si le composant a été surdosé, l'erreur sera automatiquement prise en considération lors du versement des composants qui suivent.
5. Immédiatement après chaque composant, la balance contrôle si les composants préalablement dosés doivent être redosés. Si oui: Redoser les composants affichés et confirmer à chaque fois avec la touche «**Next Comp**». Répéter cette étape, jusqu'à ce que tous les composants soient redosés.
6. Répéter les étapes 3, 4 et 5, jusqu'à ce que tous les composants soient dosés. Confirmer le dernier composant avec la touche «**Last Comp**».

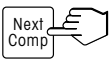

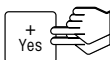







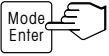





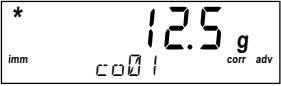

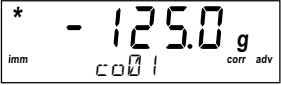

Lorsque la formulation est clôturée, la balance affiche "done", puis le poids final du mélange.



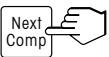
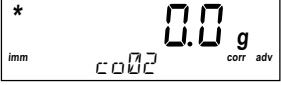
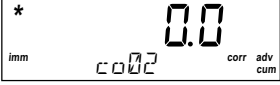





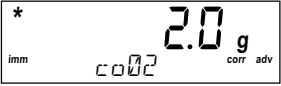
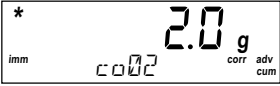

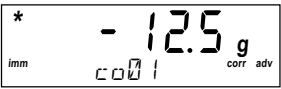
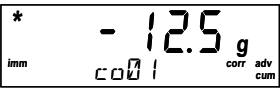

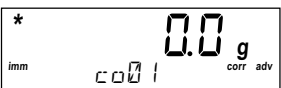
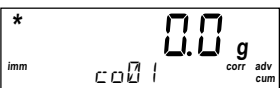
### Exemple

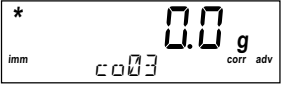
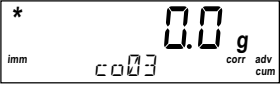
Formulation constituée de: 1<sup>er</sup> composant 125 g, 2<sup>e</sup> composant 20 g, 3<sup>e</sup> composant 5 g

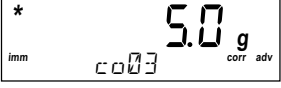
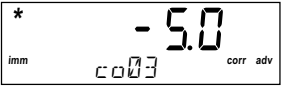
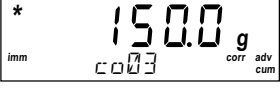
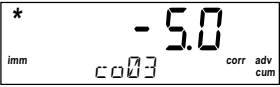
Aucun facteur, aucune tolérance sélectionnés. Le 2<sup>e</sup> composant est incorrectement dosé (22.0 g au lieu de 20.0 g)

Action	"ADV ABS IMM"	"ADV CUM IMM"
Placer le récipient vide et tarer 		
Démarrer la formulation 		
Saisir chiffre par chiffre le poids cible du 1 <sup>er</sup> composant (125 g)		
1 <sup>er</sup> chiffre 		
		

Action	"ADV ABS IMM"	"ADV CUM IMM"
2 <sup>e</sup> chiffre  	 	 
3 <sup>e</sup> chiffre  	 	 
Confirmer le poids cible saisi 		
Verser le 1 <sup>er</sup> composant 		
Confirmer le dosage 		
Saisir chiffre par chiffre le poids cible du 2 <sup>e</sup> composant 20 g (ABS)/145 g (CUM) et confirmer (pour la procédure, voir 1 <sup>er</sup> composant) 	 	 
Verser le 2 <sup>e</sup> composant 		
	Le 2 <sup>e</sup> composant est surdosé de 2 g	

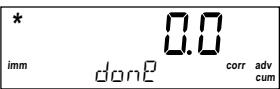
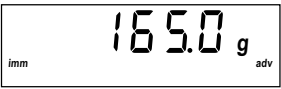
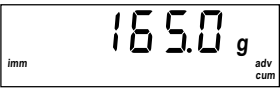
Action	"ADV ABS IMM"	"ADV CUM IMM"
Confirmer le dosage 		
	Remarque: Suite à l'erreur commise lors du dosage du 2 <sup>e</sup> composant, le 1 <sup>er</sup> composant doit être redosé de 12.5 g.	
Redoser le 1 <sup>er</sup> composant de 12.5 g 		
Confirmer le redosage 		
Saisir chiffre par chiffre le poids cible du 3 <sup>e</sup> composant 5 g (ABS)/150 g (CUM) et confirmer (pour la procédure, voir 1 <sup>er</sup> composant) 	 	 
Verser le 3 <sup>e</sup> composant 		
	Remarque: L'erreur commise lors du dosage du 2 <sup>e</sup> composant est déjà prise en compte lors du dosage du 3 <sup>e</sup> composant. 5.5 g ont été effectivement dosés, alors que la balance affichait 0.0.	
Confirmer le (dernier) dosage 		
	Le processus de formulation est clôturé. Le poids final effectif du mélange est affiché.	
		

## 6 Le Master Mode

Le Master Mode permet de modifier les paramètres de la balance et d'activer les fonctions.

### 6.1 Appel du Master Mode

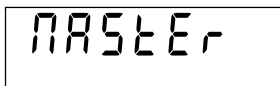

En mode pesage, maintenir pressée la touche **«Menu»** jusqu'à ce qu'apparaisse l'affichage ci-contre.

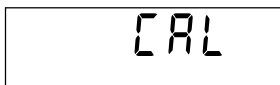
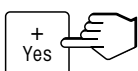

Dans un délai de 3 secondes, presser la touche **«Yes»** (sinon la balance retourne en mode pesage). Ensuite apparaît le premier bloc du menu du Master Mode.

### 6.2 Vue d'ensemble du menu du Master Mode

Utilisation du Master Mode: Confirmer l'option avec **«Yes»**, rejeter l'option avec **«No»**.

Affichage/Paramétrages	Fonction/Remarques
CAL	Étalonnage de la balance (voir chapitre 6.3, non disponible pour les balances vérifiées)
SCALE	Paramétrages de la balance
Resolution	Sélection de la résolution (non disponible pour les balances vérifiées) "Full Range" 0 ... 7100 g / 0.1 g (paramétrage d'origine) "Delta Range" 0 ... 999.95 g / 0.05 g, 1000 ... 7100 g / 0.1 g
Unit	Sélection de l'unité de poids (non disponible pour les balances vérifiées) g oz P Gramme (paramétrage d'origine) Once Parts (1 Part = 1/32 oz)
Backlight	Allumage/extinction de l'éclairage de l'affichage On Off activé (paramétrage d'origine) désactivé
Reset	Activation/désactivation de la fonction de mémorisation automatique (non disponible pour les balances vérifiées) On Off activée désactivée (paramétrage d'origine)
Vibrate	Sélection de l'adaptateur de vibration Normal High Low produits à peser normaux (paramétrage d'origine) environnement instable environnement très stable
Process	Sélection de l'adaptateur de processus Normal Dosing produits à peser normaux dosage, p. ex. de produits à peser liquides ou pulvérulents (paramétrage d'origine)
Reset	Réinitialisation de tous les paramètres SCALE aux paramètres d'origine Avec <b>«Yes»</b> retour aux paramètres d'origine, rejet avec <b>«No»</b>
End Scale	Quitter le bloc "SCALE" avec <b>«Yes»</b>

Affichage/Paramétrages	Fonction/Remarques
IFACE 1 / IFACE 2	Configuration interface(s)
Mode	Sélection du mode de fonctionnement
<b>d IALOG</b>	communication avec un ordinateur (paramétrage d'origine IFACE 1)
2nd IS	commande de l'affichage auxiliaire (paramétrage d'origine IFACE 2)
PM	mode balance PM
Print	communication avec une imprimante
CYCLE	impression de données en cas de modification de poids
Protocole	Sélection du protocole
<b>XON/OFF</b>	protocole Xon/Xoff (paramétrage d'origine)
PB	pas de protocole
PRR.ÉY	Sélection des bits et de la parité
7 EVEN	7 bits de données avec parité paire
7 NO P	7 bits de données sans parité
<b>8 NO P</b>	8 bits de données sans parité (paramétrage d'origine)
7 Odd	7 bits de données avec parité impaire
bRUD	Sélection de la vitesse de transmission de données
300	300, 600, 1200, 2400, 4800, <b>9600</b> (paramétrage d'origine),
⋮	19200 et 38400
38400	
Aut. Mod	Mode automatique
<b>AUT.5 IF</b>	l'interface transmet en continu des données (paramétrage d'origine IFACE 1)
PB	mode automatique désactivé (paramétrage d'origine IFACE 2)
RESET	Réinitialisation du paramétrage IFACE au paramétrage d'origine
Std On	Réinitialisation aux paramétrages d'origine avec « <b>Yes</b> », rejet avec « <b>No</b> »
End IF 1	Quitter le bloc "IFACE1" ou "IFACE2" avec « <b>Yes</b> »
List	Impression des paramétrages du Master Mode avec « <b>Yes</b> »
End	Avec « <b>Yes</b> » quitter le Master Mode. Avec « <b>Yes</b> », confirmer la demande de confirmation "Store?" pour mémoriser les paramétrages ou la rejeter avec « <b>No</b> ».

### 6.3 Réglage/étalonnage de la balance (non disponible pour les balances vérifiées)

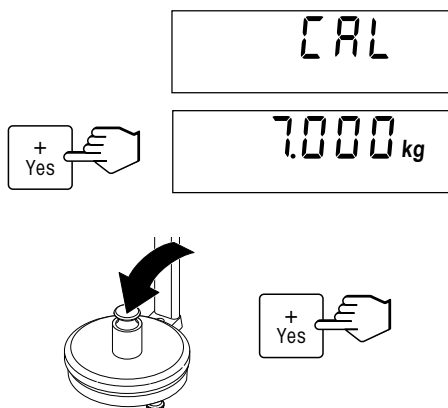

Appeler le Master Mode et sélectionner "CAL".

Décharger le plateau de la balance et presser ensuite la touche «**Yes**» pour démarrer le processus d'étalonnage. La balance affiche en clignotant le poids d'étalonnage (en fonction de la charge nominale de la balance). Avec la touche «**No**» d'autres poids d'étalonnage peuvent être sélectionnés.

Placer sur le plateau le poids d'étalonnage conformément à l'affichage et confirmer avec «**Yes**».

Remarque: L'étalonnage peut être **interrompu** à tout moment par une pression prolongée de la touche «**On/Off**».

Attendre que l'étalonnage se soit clôturé avec succès (cela est confirmé sur l'affichage par "done") et que la balance soit retournée dans le mode pesage.

## 7 Messages d'erreur



### Surcharge

Décharger la balance ou réduire la précharge.

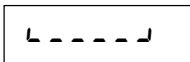

### Sous-charge

Placer le plateau sur la balance et s'assurer que celui-ci peut bouger librement.

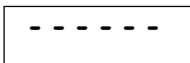

### Le résultat de pesée reste instable

1. Assurer un environnement stable
2. S'assurer que le plateau de la balance peut bouger librement
3. Modifier le paramétrage de l'adaptateur de vibration (chap. 6.2)

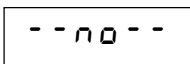

### Fonction non exécutée

La fonction appelée n'a pas pu être exécutée.

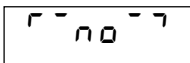

### Mise à zéro non possible (surcharge/sous-charge)

S'assurer que la mise à zéro ne soit pas exécutée en cas de surcharge ou de sous-charge.

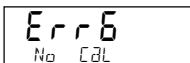

### Pas de réglage/d'étalonnage

Débrancher et rebrancher la fiche secteur. Si le message apparaît à nouveau, régler/étalonner la balance (chapitre 6.3). En cas d'échec, contacter le revendeur ou l'agence.

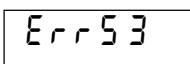

### Erreur de total de contrôle EARM

Débrancher et rebrancher la fiche secteur. Si le message apparaît à nouveau, contacter le revendeur ou l'agence.

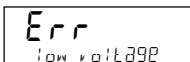

### Sous-tension

La tension de sortie de l'adaptateur secteur est trop faible. Le remplacer par un adaptateur ayant une tension de sortie correcte.



### Précision d'affichage

Lors de la formulation, saisie de la valeur de consigne avec une résolution trop fine. Adapter la valeur de la précision d'affichage de la balance (p. ex. si saisie 15.01 g pour une précision d'affichage de 0.05 g).

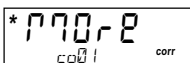

### Quantité de consigne non encore atteinte

Quantité de consigne du composant non encore atteinte. Redoser jusqu'à ce que la quantité de consigne soit atteinte.



### Formulation annulée

Formulation annulée par une pression prolongée de la touche «Last Comp».



## 8 Interfaces / Accessoires

### 8.1 Définition d'interfaces

En standard, la balance PS7 est dotée d'une interface RS232C double et la PS7-X d'une interface RS232C single. L'interface/les interfaces sont disponibles via le connecteur Sub-D à 9 broches. La longueur maximale de la ligne est de 15 m. La configuration des interfaces s'effectue dans le Master Mode (voir chapitre 6.2).

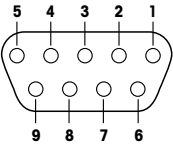
Interface(s) intégrée(s) RS232C, Sub D à 9 broches, f		Brochage pour PS7	Brochage pour PS7-X	2 interfaces pour utilisation du câble Y (accessoire), uniquement pour PS7	
Brochage				COM1	COM2
	Broche 1	nc	nc	—	—
	Broche 2	TxD 1	TxD 1	TxD 1	TxD 2
	Broche 3	RxD 1	RxD 1	RxD 1	RxD 2
	Broche 4	nc	nc	—	—
	Broche 5	GND	GND	GND	GND
	Broche 6	nc	nc	—	—
	Broche 7	RxD 2	nc	—	—
	Broche 8	TxD 2	nc	—	—
	Broche 9	VCC (5 V, ≤ 50 mA)	nc	—	VCC (5 V, ≤ 50 mA)

TxD: Transmission de données RxD: Réception de données

GND: Terre de signalisation VCC: Alimentation (+5 V, ≤ 50 mA)

nc: not connected (non raccordée)

### 8.2 Accessoires

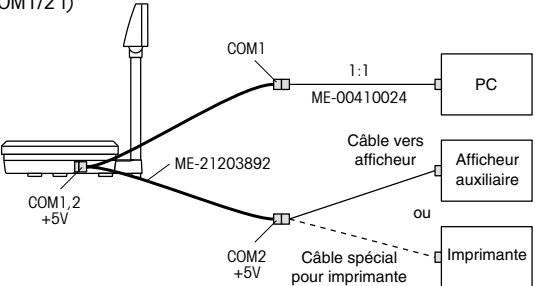
Accessoire	N° d'article
Housse de protection (ensemble de 5 pièces)	21302841
Câble Y (Sub D à 9 broches, m, COM1/2 f) 	21203892
Câble RS232 pour PC 1,8 m (Sub D à 9 broches, m/f, 1:1)	00410024

## 9 Caractéristiques techniques / Directives et normes d'essai

### 9.1 Caractéristiques techniques

Portée	7100 g
Précision d'affichage	Full Range: 0.1 g (0 ... 7100 g) Delta Range: 0.05 g (0 ... 999.95 g), 0.1 g (1000 ... 7100 g)
Temps de stabilisation	env. 1.0 seconde
Linéarité	0.2 g
Alimentation électrique	via adaptateur secteur/unité d'alimentation 13.5 VAC, 4 W
Unités de poids	g, oz et P (1 Part = 1/32 oz)
Afficheur	LCD (afficheur à cristaux liquides), rétroéclairé
Conditions ambiantes	Plage de température: +10 ... +30°C Humidité relative de l'air: 20 ... 80% hr (sans condensation)
Poids net/brut	3.4 kg / 4.5 kg
Classe de surtension:	II
Degré d'encrassement:	2

### Dimensions

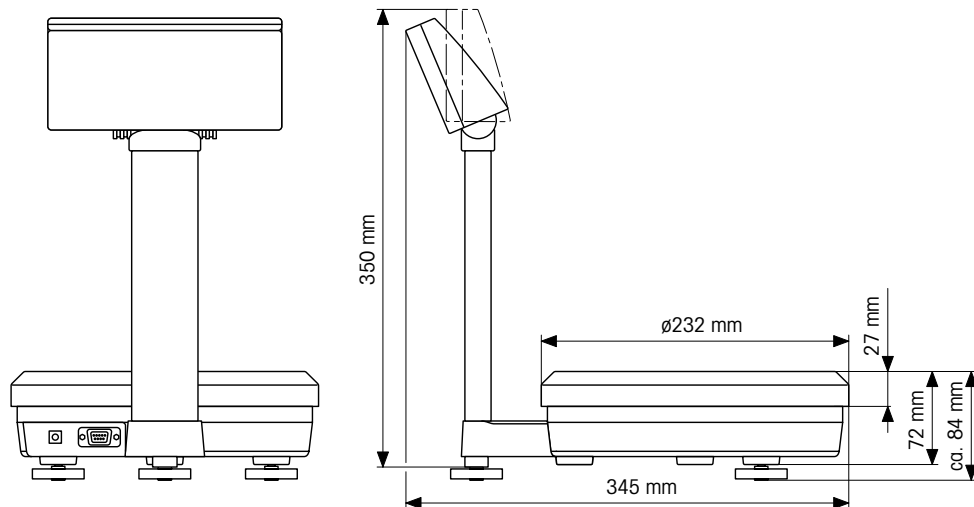



## 9.2 Directives et normes d'essai

### Gamme de balances PS7

Nous déclarons sous notre seule responsabilité, que le produit, auquel s'applique la présente déclaration, est conforme aux directives de la CEE ci-dessous mentionnées.

Remarques: Une approbation de modèle CEE est disponible pour les balances vérifiées/soumises à vérification. L'année de la première vérification est mentionnée à côté du marquage CE. Ces balances sont vérifiées en usine et portent elles-mêmes ainsi que sur leur emballage le signe «M». Si la lettre M apparaît sur fond plein, la balance peut immédiatement être mise en service. Si le fond est séparé et hachuré, la balance doit être vérifiée sur site par le service METTLER TOLEDO certifié. Dans la mesure où la durée de validité de la vérification est limitée dans les différents pays selon les prescriptions nationales, l'utilisateur doit lui-même faire revérifier les balances qu'il emploie.

Marque	Directive CEE	Contrôle selon la norme
	73/23/CEE Basse tension	EN61010-1  CAN/CSA-22.2 No. 1010.1-92
	89/336/CEE Compatibilité électromagnétique	EN61326-1 Emissions parasites classe B EN61000-3-2 Harmoniques EN61000-3-3 Fluctuations de tension EN61326-1 Immunité (domaine industriel) AS/NZS2064.1/2, AS/NZS3548 AS/NZS4251.1, AS/NZS4252.1
	90/384CEE <sup>1)</sup> Balances à fonctionnement non automatique	EN45501 <sup>1)</sup> Aspects métrologiques

<sup>1)</sup> ne s'applique qu'aux balances vérifiées

Mettler-Toledo GmbH  
Industrial BA IND-N  
Nänikon, Mai 2001

Johannes Schmid  
General Manager  
Standard Industrial

Marlise Ackermann  
Project Manager  
Product Area General Weighing

### USA

*This equipment has been tested and found to comply with the limits for a Class A digital device, pursuant to both Part 15 of the FCC Rules and the radio interference regulations of the Canadian Department of Communications. These limits are designed to provide reasonable protection against harmful interference when the equipment is operated in a commercial environment. This equipment generates, uses and can radiate radio frequency energy and, if not installed and used in accordance with the instruction manual, may cause harmful interference to radio communications. Operation of this equipment in a residential area is likely to cause harmful interference, in which case the user will be required to correct the interference at his own expense.*

### Canada







*ICES-001 Notice for Industrial, Scientific and Medical Radio Frequency Generators: This ISM apparatus meets all requirements of the Canadian Interference-Causing Equipment Regulations. Please note that this requirement is only for generators which operate at over 10 kHz.*

*Avis de l'ICES-001, générateurs de radiofréquences dans le domaine industriel, scientifique et médical: Cet appareil ISM (industriel, scientifique et médical) satisfait à toutes les exigences définies par la réglementation canadienne en matière d'équipements générant des perturbations radioélectriques. Veuillez noter qu'il s'agit d'une exigence concernant uniquement les générateurs fonctionnant au-delà de 10 kHz.*

**Gamme de balances PS7-X**

Nous déclarons sous notre seule responsabilité, que le produit, auquel s'applique la présente déclaration, est conforme aux directives de la CEE ci-dessous mentionnées.

Remarques: Une approbation de modèle CEE est disponible pour les balances vérifiées/soumises à vérification. L'année de la première vérification est mentionnée à côté du marquage CE. Ces balances sont vérifiées en usine et portent elles-mêmes ainsi que sur leur emballage le signe «M». Si la lettre M apparaît sur fond plein, la balance peut immédiatement être mise en service. Si le fond est séparé et hachuré, la balance doit être vérifiée sur site par le service METTLER TOLEDO certifié. Dans la mesure où la durée de validité de la vérification est limitée dans les différents pays selon les prescriptions nationales, l'utilisateur doit lui-même faire revérifier les balances qu'il emploie.

Marque	Directive CEE	Contrôle selon la norme
  	94/9/CEE (ATEX)	EN50014, EN50020  FMRC 3600, 3610, 3810  CSA-C22.2 No. 157-92 CSA-C22.2 No. 142-M 1987
	73/23CEE Basse tension	EN60950-1
 	89/336CEE Compatibilité électromagnétique	N61326-1 Emissions parasites classe B EN61000-3-2 Harmoniques EN61000-3-3 Fluctuations de tension EN61326-1 Immunité (domaine industriel)  AS/NZS2064.1/2, AS/NZS3548 AS/NZS4251.1, AS/NZS4252.1

Mettler-Toledo GmbH  
Industrial BA IND-N  
Nänikon, Mai 2001

Johannes Schmid  
General Manager  
Standard Industrial

Marlise Ackermann  
Project Manager  
Product Area General Weighing

**USA**

*This equipment has been tested and found to comply with the limits for a Class A digital device, pursuant to both Part 15 of the FCC Rules and the radio interference regulations of the Canadian Department of Communications. These limits are designed to provide reasonable protection against harmful interference when the equipment is operated in a commercial environment. This equipment generates, uses and can radiate radio frequency energy and, if not installed and used in accordance with the instruction manual, may cause harmful interference to radio communications. Operation of this equipment in a residential area is likely to cause harmful interference, in which case the user will be required to correct the interference at his own expense.*

**Canada**

*ICES-001 Notice for Industrial, Scientific and Medical Radio Frequency Generators: This ISM apparatus meets all requirements of the Canadian Interference-Causing Equipment Regulations. Please note that this requirement is only for generators which operate at over 10 kHz.*

*Avis de l'ICES-001, générateurs de radiofréquences dans le domaine industriel, scientifique et médical: Cet appareil ISM (industriel, scientifique et médical) satisfait à toutes les exigences définies par la réglementation canadienne en matière d'équipements générant des perturbations radioélectriques. Veuillez noter qu'il s'agit d'une exigence concernant uniquement les générateurs fonctionnant au-delà de 10 kHz.*

# 1 Introducción

## 1.1 Generalidades

Gracias por comprar la **balanza para mezcla de colores PS7 o su variante PS7-X para atmósferas explosivas**. Las balanzas PS7/PS7-X permiten pesar componentes con una relación de mezclas previamente fijada. La balanza incorpora diversos modos de corrección para compensar los posibles errores en el pesaje de los componentes. Con el interface RS232 integrado, la balanza se conecta a una impresora, un ordenador o a una pantalla auxiliar.

Lea con atención las instrucciones de manejo y siga las recomendaciones allí contenidas.

## 1.2 Seguridad y medio ambiente



- Utilice la **balanza PS7 en entornos no expuestos a explosiones** (con mezclas explosivas de gases, vapores, niebla y polvo).

Utilice una balanza del tipo **PS7-X en zonas explosivas**. Es **imprescindible** conectar estas balanzas mediante la **fuelle de alimentación certificada** de METTLER TOLEDO. Siga estrictamente las indicaciones de instalación de la fuente de alimentación. Debido al peligro que suponen las cargas electrostáticas en zonas explosivas sólo es posible utilizar fundas protectoras realizadas con material antiestático.

- Conecte la balanza a la alimentación eléctrica **sólo con el adaptador de red integrado (PS7)** o con la **fuelle de alimentación (PS7-X)**. Cerciérese de que el valor de tensión impreso coincide con la tensión de red local. Compruebe con regularidad los cables del adaptador de red/fuelle de alimentación. Si se dañan los cables o el adaptador de red/fuelle de alimentación, no ponga en marcha la balanza.

- Utilice únicamente accesorios y periféricos recomendados.

- Recuerde que la balanza es un instrumento de precisión. Trátela con cuidado. Evite darle golpes o colocar obre ella cargas más pesadas que las permitidas.

- **¡Desenchufe siempre la balanza antes de limpiarla!**

Limpieza: utilice un paño húmedo (evite los ácidos, los detergentes y los disolventes). Si está muy sucia, retire primero el platillo, la funda protectora (si la hay) y las patas regulables (sólo en balanzas verificadas) y límpielos por separado. Respete la normativa específica de la marca referente a los intervalos de limpieza y los productos admisibles.

- Cumpla las normas medioambientales a la hora de eliminar su balanza.

## 1.3 Indicaciones para modelos verificados

En los modelos verificados las siguientes funciones están desactivadas:

- Formulación (pesaje factorial y formulación con corrección)
- Modificación de la unidad de pesada (la unidad de pesada en balanzas verificadas está ajustada por defecto en "g")
- Calibración (los modelos verificados deben ser calibrados por un centro de servicio postventa autorizado por METTLER TOLEDO)

## 2 Puesta en marcha

### 2.1 Colocación y orientación de la balanza

¡La colocación correcta facilita en gran medida la exactitud de los resultados de pesada!



Elija una posición estable, libre de vibraciones y lo más horizontal posible.

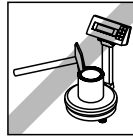

No utilice nunca un martillo para cerrar los botes de pintura que están depositados sobre el platillo.



Evite los cambios de temperatura y los rayos solares directos. Atención a las condiciones ambientales admisibles.

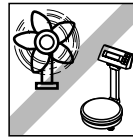

Evite las corrientes (p. ej. de ventiladores o climatizadores).

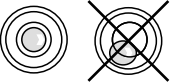

**Sólo balanzas verificadas:** oriente la balanza horizontalmente girando las patas regulables. La burbuja de aire debe situarse dentro del círculo interior.

Advertencia: las balanzas verificadas deben ser ajustadas en su lugar de montaje por el servicio postventa autorizado de METTLER TOLEDO.

#### Traslados importantes

Recomendamos que calibre su balanza la primera vez que la ponga en marcha (ver capítulo 6.3). Las balanzas verificadas están sujetas a las normas nacionales y se verifican en su lugar de emplazamiento.

### 2.2 Conexión a la alimentación eléctrica

**PS7-X para zonas explosivas:** la conexión de las balanzas del tipo PS7-X para zonas explosivas requiere expresamente una fuente de alimentación certificada. Preste atención y siga exactamente las indicaciones del manual de instalación específico para la fuente de alimentación.

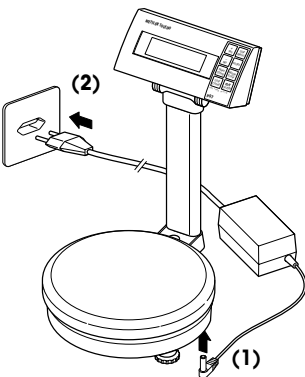

**¡Atención!** Antes de conectar el adaptador a la red, compruebe si el valor de tensión impreso coincide con la tensión de red local.

**¡Importante!** En primer lugar, una el adaptador de red al conector situado en la parte inferior de la balanza (1). A continuación, introduzca la clavija del adaptador de red en el enchufe (2).

La balanza realiza entonces una prueba de indicación, donde se muestran brevemente todos los segmentos y la versión de software. La balanza está lista para funcionar cuando aparece en el indicador de cero.

### 3 Funciones de teclas

Teclas	Función con	
	Pulsación breve	Pulsación prolongada
<b>O/T</b> On/Off	Tarar balanza **	Conectar y desconectar balanza **
Factor	Seleccionar factor de conversión, para pesar una cantidad mayor o menor de una fórmula	Reponer factor de conversión a "1" (Pesada sin factor)
Unit Menu	Modificar unidad de pesada	Acceso a Master Mode ** (ver capítulo 6.1)
Next Comp	Confirmar peso final de un componente pesado y continuar con el componente siguiente	—
Last Comp	Confirmar el peso final del último componente pesado de una fórmula	Cancelar el proceso de formulación
Mode Enter	Seleccionar método de formulación o tolerancia <b>Modo de formulación avanzado</b> Introducir siguiente cifra del peso final	Confirmar método de formulación o tolerancia seleccionados <b>Modo de formulación avanzado</b> Confirmar peso final introducido
+ Yes	Función dependiente del modo de trabajo seleccionado <b>Master Mode **</b> Confirmar ajuste actual <b>Modo de formulación estándar</b> Aumentar valor teórico del componente <b>Modo de formulación avanzado</b> Aumentar valor teórico del componente	<b>Master Mode</b> — <b>Modo de formulación estándar</b> Aumentar valor teórico del comp. en 1,0 <b>Modo de formulación avanzado</b> —
- No	Función dependiente del modo de trabajo seleccionado <b>Master Mode **</b> Desechar ajuste actual <b>Modo de formulación estándar</b> Reducir valor teórico del componente <b>Modo de formulación avanzado</b> Reducir valor teórico del componente	<b>Master Mode</b> — <b>Modo de formulación estándar</b> Reducir valor teórico del componente en 1,0 (manteniendo pulsada la tecla, el valor se reduce automáticamente) <b>Modo de formulación avanzado</b> Volver a la última cifra

\*\* Las balanzas verificadas sólo tienen activadas las siguientes teclas

## 4 Pesaje

### 4.1 Conexión/Desconexión y selección de la unidad de pesada

#### Conexión/Desconexión



La balanza se conecta y desconecta con la **pulsación prolongada** de la tecla «**O/T**». Una vez conectada, la balanza realiza una prueba de indicación. Cuando aparece el indicador de peso, la balanza se pone a cero y ya está lista para funcionar.

#### Selección de la unidad de pesada (no disponible en balanzas verificadas)



Cambie de unidad de pesada "g" (gramo) a "oz" (onza) y "P" (piezas) con la **pulsación breve** de la tecla «**Unit**».

### 4.2 Pesadas sencillas

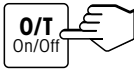
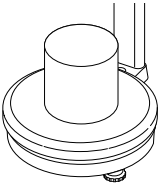

Deposite el recipiente de pesada. Para tarar, pulse brevemente la tecla «**O/T**». Verá enseguida el indicador de cero.

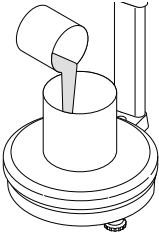

Añada la cantidad deseada de producto.

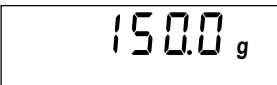

Espere a que se apague el control de estabilidad (símbolo anular en pantalla) y anote el resultado de pesada.



## 5 Formulación

Atención: **En las balanzas verificadas las funciones de formulación están desactivadas** (pesaje factorial, formulación con corrección).

### 5.1 Selección del factor

Seleccione un factor (multiplicador) para medir una cantidad mayor o menor de una fórmula predeterminada.

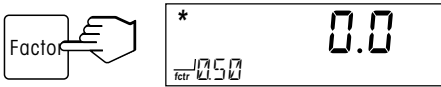

Active el pesaje con factor con la **pulsación breve** de la tecla «**Factor**». En la parte inferior izquierda de la pantalla aparece el factor utilizado en la última pesada con multiplicador (p. ej. 0,50).



A continuación pulse **varias veces** la tecla «**Factor**», hasta que aparezca el factor deseado (0,20 ... 5,00).

En la pesada siguiente se utiliza el peso final (p. ej. 1.000 g) de un componente según la fórmula. No obstante, dependiendo del factor seleccionado, el peso efectivo corresponde a una cantidad mayor o menor.

**Ejemplo 1:** peso según fórmula de 1.000 g, factor seleccionado 0,50 (para media cantidad). Indicador: 1.000, peso efectivo: 500 g

**Ejemplo 2:** peso según fórmula de 1.000 g, factor seleccionado 3,00 (para un tercio de la cantidad). Indicador: 1.000, peso efectivo: 3.000 g



**Desactivar pesaje con factor:** desactivar con **pulsación prolongada** de la tecla «**Factor**».

El indicador del factor desaparece y el factor se repone a 1.

## 5.2 Métodos de formulación

La PS7 ofrece diversos métodos de formulación. Cada método se compone de:

– **Modo de formulación:**

- **Formulación estándar "STJ":** en este modo se pesa y se confirma la cantidad deseada de un componente. En caso de dosificación errónea, antes de pesar el siguiente componente introduzca el peso final efectivo del componente pesado incorrectamente. El fallo se subsana automáticamente cuando se pesan los componentes siguientes.
- **Formulación avanzada "ADV":** en este modo se introduce primero el peso final de un componente. Luego se pesa y se confirma el componente. Los posibles errores de pesaje se subsanan automáticamente cuando se pesan los componentes siguientes.

– **Tipo de indicación:**

- **Indicador absoluto "ABS":** indicador del peso absoluto de un componente.
- **Indicador acumulativo "CUM":** indicador del peso acumulativo.

– **Modo de corrección:**

- **Corrección "IMM":** corrección inmediata después de cada pesada incorrecta de un componente
- **Corrección "END":** corrección al final de la formulación

Por combinación resultan **8 métodos de formulación distintos**:

Método de formulación	Modo de formulación		Tipo de indicación		Método de corrección	
	Estándar	Avanzado	Absoluto	Acumulativo	Inmediato	Al final
STJ ABS END → Cap. 5.5	X		X			X
STJ CUM END → Cap. 5.5	X			X		X
STJ ABS IMM → Cap. 5.6	X		X		X	
STJ CUM IMM → Cap. 5.6	X			X	X	
ADV ABS END → Cap. 5.7		X	X			X
ADV CUM END → Cap. 5.7		X		X		X
ADV ABS IMM → Cap. 5.8		X	X		X	
ADV CUM IMM → Cap. 5.8		X		X	X	

### 5.3 Selección del método de formulación



Corr P  
STD ABS END

**Pulse brevemente** la tecla «**Mode**». En la pantalla aparece el último método de formulación seleccionado (configuración de fábrica: "STD ABS END").



Corr P  
ADV ABS END

De nuevo, **pulse brevemente** la tecla «**Mode**» y seleccione el método de formulación deseado (p. ej. "ADV ABS END").

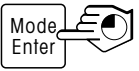

tol P  
10% tol adv

Para confirmar el método de formulación seleccionado, **pulsación prolongada** de la tecla «**Mode**».

Si ha seleccionado un método de formulación avanzado ("ADV ..."), aparecerá la pantalla de selección de la tolerancia. En caso de tolerancia rebasada, corrija cada uno de los componentes.



tol P  
15% tol adv

De nuevo, **pulse brevemente** la tecla «**Mode**» para seleccionar la tolerancia más/menos deseada en % (no, 0,5 ... 15,0).

Advertencia: "no" significa tolerancia de cero.

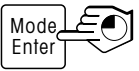

Confirme la tolerancia (p. ej. 1,5%) con **pulsación prolongada** de la tecla «**Mode**». La balanza está lista para la formulación.

**Advertencia:** el método de formulación seleccionado permanece activado hasta que se selecciona otro distinto.

### 5.4 Indicaciones para la formulación

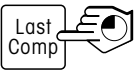

#### Cancelar formulación

Es posible cancelar la formulación en cualquier momento mediante **pulsación prolongada** de la tecla «**Last Comp**».

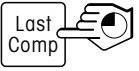

#### Imprimir informe de formulación

Si su balanza está conectada a una impresora, al terminar la formulación puede imprimir el informe mediante **pulsación prolongada** de la tecla «**Last Comp**».

```
Mode :STD ABS END
Components:
co01
  target: 100.0 g
  true  : 110.0 g
co02
  target: 20.0 g
  true  : 22.0 g
co03
  target: 5.0 g
  true  : 5.5 g
```

## 5.5 Formulación con "STD ABS END" y "STD CUM END"







### Procedimiento



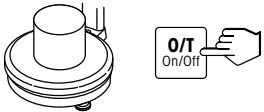
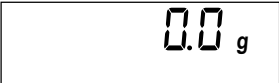
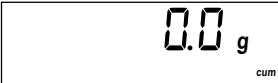



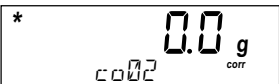

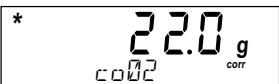
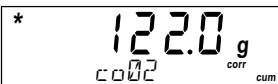

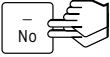

1. Deposite el recipiente vacío y tárelo.
2. Halle el peso final del componente y confirme la pesada inicial correcta con la tecla «Next Comp». En caso de sobrellenado de componente, introduzca primero el peso teórico con la tecla «←» y confirme pulsando «Next Comp».  
Advertencia: el error se subsana automáticamente cuando se añaden los componentes siguientes.  
Repita este paso hasta haber pesado la totalidad de los componentes. Confirme el último componente con la tecla «Last Comp».
3. La balanza verifica si es preciso redosificar algún componente. En caso afirmativo: redosifique los componentes indicados y confirme cada vez con la tecla «Next Comp». Repita este paso hasta haber redosificado la totalidad de los componentes.

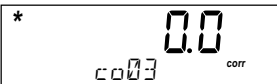
Al terminar la formulación, la balanza muestra en pantalla "done" y después el peso definitivo de la mezcla.

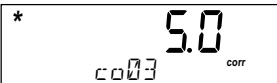
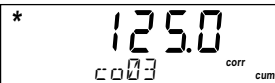
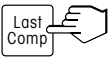
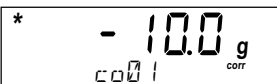
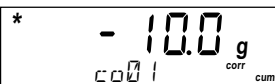
### Ejemplo

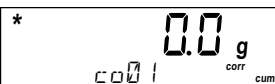
Fórmula consistente en: 1<sup>er</sup> componente 100 g, 2<sup>o</sup> componente 20 g, 3<sup>er</sup> componente 5 g  
Ningún factor seleccionado. El 2<sup>o</sup> componente se pesa mal (22,0 g en lugar de 20,0 g)

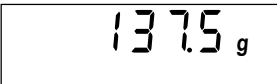
Acción	"STD ABS END"	"STD CUM END"
Depositar y tarar el recipiente vacío 		
Añadir el 1 <sup>er</sup> componente (valor teórico 100 g) 		
Confirmar el 1 <sup>er</sup> componente 		
Añadir el 2 <sup>o</sup> componente (valor teórico 20 g) 	 Sobrellenado del 2 <sup>o</sup> componente en 2 g	

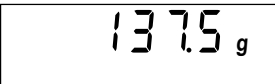
Acción	"STD ABS END"	"STD CUM END"
Introducir el valor teórico del 2º componente 20 g (ABS)/120 g (CUM) 		
Confirmar el valor teórico 		
Añadir el 3º componente (valor teórico 5 g) 		 Advertencia: el error en la pesada del 2º componente se subsana al pesar el 3º componente, es decir, el peso efectivo del 3º componente es de 5,5 g (en lugar de 5,0 g). No obstante, este exceso de dosificación no se muestra; en pantalla aparece el valor teórico según la fórmula (5,0 y 125,0).
Confirmar el 3º (y último) componente 		 Advertencia: el 1º componente debe redosificarse en 10 g debido al error en la pesada del 2º componente.
Redosificar el 1º componente en 10 g 		
Confirmar la corrección 	 	  Fin del proceso de formulación. En pantalla aparece el peso definitivo de la mezcla.

## 5.6 Formulación con "STD ABS IMM" y "STD CUM IMM"









### Procedimiento

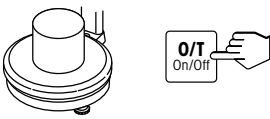
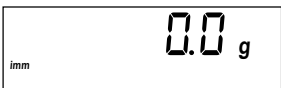
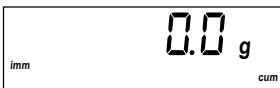



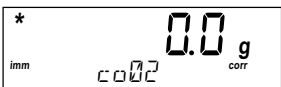





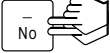

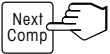
1. Deposite el recipiente vacío y tárelo.
2. Halle el peso final del componente y confirme la pesada inicial correcta con la tecla «Next Comp». En caso de sobrellenado de componente, introduzca primero el peso teórico con la tecla «←» y confirme pulsando «Next Comp». El error se subsana automáticamente cuando se añaden los siguientes componentes.
3. La balanza verifica inmediatamente después de cada componente si es preciso redosificar los componentes pesados hasta el momento. En caso afirmativo: redosifique los componentes indicados y confirme cada vez con la tecla «Next Comp». Repita este paso hasta haber dosificado la totalidad de los componentes.
4. Repita los pasos 2 y 3 hasta haber pesado la totalidad de los componentes. Confirme el último componente con la tecla «Last Comp».

Al terminar la formulación, la balanza muestra en pantalla "done" y después el peso definitivo de la mezcla.

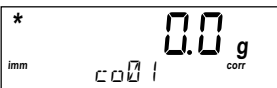
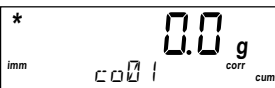
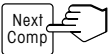
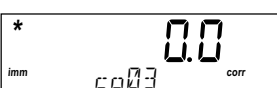
### Ejemplo

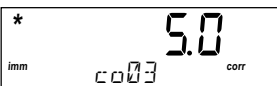
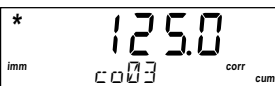
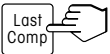
Fórmula consistente en: 1<sup>er</sup> componente 100 g, 2<sup>o</sup> componente 20 g, 3<sup>er</sup> componente 5 g  
Ningún factor seleccionado. El 2<sup>o</sup> componente se pesa mal (22,0 g en lugar de 20,0 g)

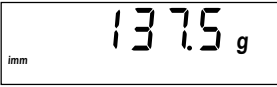
Acción	"STD ABS IMM"	"STD CUM IMM"
Depositar y tarar el recipiente vacío 		
Añadir el 1 <sup>er</sup> componente (valor teórico 100 g) 		
Confirmar el 1 <sup>er</sup> componente 		
Añadir el 2 <sup>o</sup> componente (valor teórico 20) 	 <p>Sobrellenado del 2<sup>o</sup> componente en 2 g</p>	

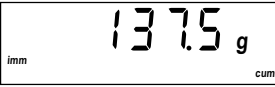
Acción	"STD ABS IMM"	"STD CUM IMM"
Introducir el valor teórico del 2º componente 20 g (ABS)/120 g CUM) 		
Confirmar el valor teórico 	 <p data-bbox="465 464 741 517">Advertencia: el 1<sup>er</sup> componente debe redosificarse en 10 g debido al error en la pesada del 2º componente.</p>	
Redosificar el 1º componente 		
Confirmar la corrección 		
Añadir el 3º componente (valor teórico 5 g) 	 <p data-bbox="465 927 741 1059">Advertencia: el error en la pesada del 2º componente se subsana al pesar el 3º componente, es decir, el peso efectivo del 3º componente es de 5,5 g (en lugar de 5,0 g). No obstante, este exceso de dosificación no se muestra; en pantalla aparece el valor teórico según la fórmula (5,0 y 125,0).</p>	
Confirmar el 3º (y último) componente 	 <p data-bbox="465 1185 741 1238">Fin del proceso de formulación. En pantalla aparece el peso definitivo de la mezcla.</p> 	 

## 5.7 Formulación con "ADV ABS END" y "ADV CUM END"









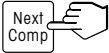

### Procedimiento

1. Deposite el recipiente vacío y tárelo.
  2. Pulse la tecla «Next Comp» para iniciar la formulación.
  3. Introduzca cifra por cifra el peso final del componente indicado (elija la cifra con «+» y «-» y confirme con una pulsación breve de la tecla «Enter»). Confirme el peso final introducido con una pulsación prolongada de la tecla «Enter».
  4. Dosifique hasta cero el componente (también por sobrellenado) y confirme la pesada inicial con la tecla «Next Comp». En caso de sobrellenado de componente, el error se subsana automáticamente cuando se añaden los siguientes componentes.
  5. Repita los pasos 3 y 4 hasta haber pesado la totalidad de los componentes. Confirme el último componente con la tecla «Last Comp».
  6. La balanza verifica si es preciso redosificar algún componente. En caso afirmativo: redosifique los componentes indicados y confirme cada vez con la tecla «Next Comp».
- Repita este paso hasta haber redosificado la totalidad de los componentes.





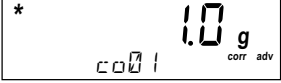

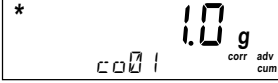





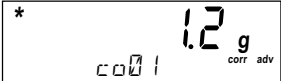

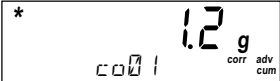



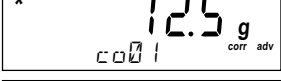
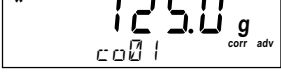
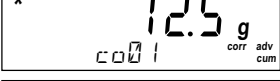
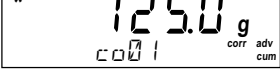

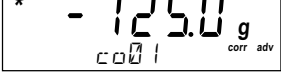
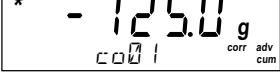

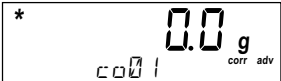
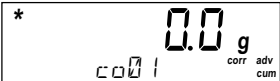

Al terminar la formulación, la balanza muestra en pantalla "done" y después el peso definitivo de la mezcla.

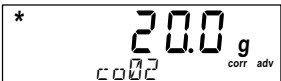

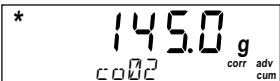

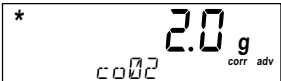
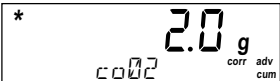

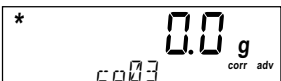



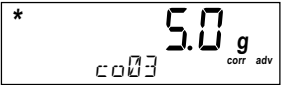
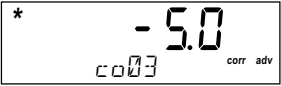

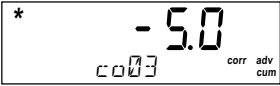

### Ejemplo

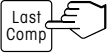
Fórmula consistente en: 1<sup>er</sup> componente 125 g, 2<sup>o</sup> componente 20 g, 3<sup>er</sup> componente 5 g  
Ningún factor y ninguna tolerancia seleccionados. El 2<sup>o</sup> componente se pesa mal (22,0 g en lugar de 20,0 g)

Acción	"ADV ABS END"	"ADV CUM END"
Depositar y tarar el recipiente vacío 		
Iniciar la formulación 		
Introducir cifra por cifra el peso final del 1 <sup>er</sup> componente (125 g)  1 <sup>a</sup> cifra   	  	  

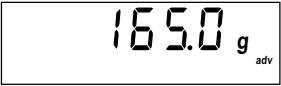
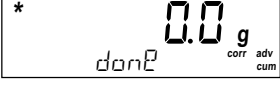
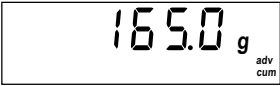

Acción	"ADV ABS END"	"ADV CUM END"
2ª cifra  	 	 
3ª cifra  	 	 
Confirmar el peso final introducido 		
Añadir el 1º componente 		
Confirmar la pesada 		
Introducir cifra por cifra el peso final del 2º componente 20 g (ABS)/145 g (CUM) y confirmar (proceso, ver 1º componente) 	 	 
Añadir 2º componente 	 Sobrellenado del 2º componente en 2 g	
Confirmar la pesada 		

Acción	"ADV ABS END"	"ADV CUM END"
<p>Introducir cifra por cifra el peso final del 3<sup>er</sup> componente 5 g (ABS)/150 g (CUM) y confirmar (proceso, ver 1<sup>er</sup> componente)</p> 	<p>* </p> <p>* </p>	<p>* </p> <p>* </p>
<p>Añadir 3<sup>er</sup> componente</p> 	<p>* </p> <p>Advertencia: el error en la pesada del 2<sup>o</sup> componente se subsana al pesar el 3<sup>er</sup> componente. El peso efectivo es de 5,5 g cuando el indicador está en 0,0.</p>	<p>* </p>
<p>Confirmar la (última) pesada</p> 	<p>* </p> <p>Advertencia: el 1<sup>er</sup> componente debe redosificarse en 12,5 g debido al error en la pesada del 2<sup>o</sup> componente.</p>	<p>* </p>
<p>Redosificar el 1<sup>er</sup> componente en 12,5 g</p> 	<p>* </p>	<p>* </p>
<p>Confirmar la redosificación</p> 	<p>* </p> <p>Fin del proceso de formulación. En pantalla aparece el peso definitivo de la mezcla.</p> <p></p>	<p>* </p> <p></p>

## 5.8 Formulación con "ADV ABS IMM" y "ADV CUM IMM"









### Procedimiento

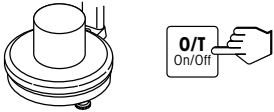

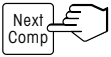
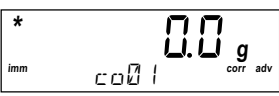
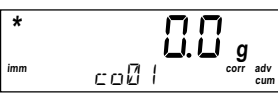

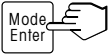
1. Deposite el recipiente vacío y tárelo.
2. Pulse la tecla «Next Comp» para iniciar la formulación.
3. Introduzca cifra por cifra el peso final del componente indicado (elija la cifra con «+» y «-» y confirme con una pulsación breve de la tecla «Enter»). Confirme el peso final introducido con una pulsación prolongada de la tecla «Enter».
4. Dosifique hasta cero el componente (también por sobrellenado) y confirme la pesada inicial con la tecla «Next Comp». En caso de sobrellenado de componente, el error se subsana automáticamente cuando se añaden los siguientes componentes.
5. La balanza verifica inmediatamente después de cada componente si es preciso redosificar los componentes pesados hasta el momento. En caso afirmativo: redosifique los componentes indicados y confirme cada vez con la tecla «Next Comp». Repita este paso hasta haber dosificado la totalidad de los componentes.
6. Repita los pasos 3, 4 y 5 hasta haber pesado la totalidad de los componentes. Confirme el último componente con la tecla «Last Comp».

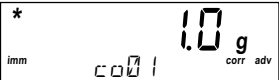

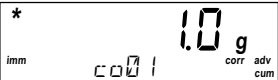

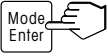
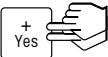
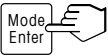

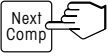
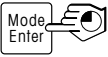



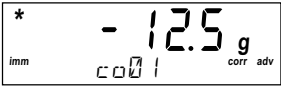





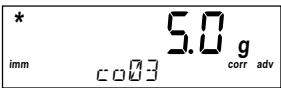
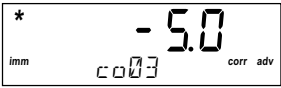

Al terminar la formulación, la balanza muestra en pantalla "done" y después el peso definitivo de la mezcla.

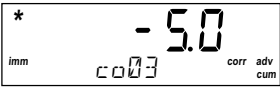
### Ejemplo

Fórmula consistente en: 1<sup>er</sup> componente 125 g, 2<sup>o</sup> componente 20 g, 3<sup>er</sup> componente 5 g  
Ningún factor y ninguna tolerancia seleccionados. El 2<sup>o</sup> componente se pesa mal (22,0 g en lugar de 20,0 g)

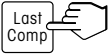
Acción	"ADV ABS IMM"	"ADV CUM IMM"
Depositar y tarar el recipiente vacío 		
Iniciar la formulación 		
Introducir cifra por cifra el peso final del 1 <sup>er</sup> componente (125 g)  1 <sup>a</sup> cifra   	  	  

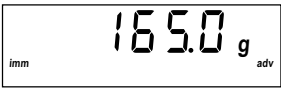
Acción	"ADV ABS IMM"	"ADV CUM IMM"
<p>2ª cifra</p>  <p>+ Yes</p>  <p>Mode/Enter</p> <p>3ª cifra</p>  <p>+ Yes</p>  <p>Mode/Enter</p> <p>Confirmar el peso final introducido</p>  <p>Mode/Enter</p>	<p>* imm 12.0 g corr adv c 0 0 1</p> <p>* imm 12.0 g corr adv c 0 0 1</p> <p>* imm 12.5 g corr adv c 0 0 1</p> <p>* imm 125.0 g corr adv c 0 0 1</p> <p>* imm - 125.0 g corr adv c 0 0 1</p>	<p>* imm 1.2 g corr adv cum c 0 0 1</p> <p>* imm 12.0 g corr adv cum c 0 0 1</p> <p>* imm 12.5 g corr adv cum c 0 0 1</p> <p>* imm 125.0 g corr adv cum c 0 0 1</p> <p>* imm - 125.0 g corr adv cum c 0 0 1</p>
<p>Añadir el 1<sup>er</sup> componente</p>  <p>1.</p>	<p>* imm 0.0 g corr adv c 0 0 1</p>	<p>* imm 0.0 g corr adv cum c 0 0 1</p>
<p>Confirmar la pesada</p>  <p>Next/Comp</p>	<p>* imm 0.0 g corr adv c 0 0 2</p>	<p>* imm 0.0 g corr adv cum c 0 0 2</p>
<p>Introducir cifra por cifra el peso final del 2º componente 20 g (ABS)/145 g (CUM) y confirme (proceso, ver 1<sup>er</sup> componente)</p>  <p>Mode/Enter</p>	<p>* imm 20.0 g corr adv c 0 0 2</p> <p>* imm - 20.0 g corr adv c 0 0 2</p>	<p>* imm 145.0 g corr adv cum c 0 0 2</p> <p>* imm - 20.0 g corr adv cum c 0 0 2</p>
<p>Añadir el 2º componente</p>  <p>2.</p>	<p>* imm 2.0 g corr adv c 0 0 2</p>	<p>* imm 2.0 g corr adv cum c 0 0 2</p>
Sobrellenado del 2º componente en 2 g		

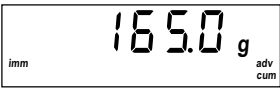
Acción	"ADV ABS IMM"	"ADV CUM IMM"
Confirmar la pesada 		
Advertencia: el 1er. componente debe redosificarse en 12,5 g debido al error en la pesada del 2º componente.		
Redosificar el 1º componente en 12,5 g 		
Confirmar la redosificación 		
Introducir cifra por cifra el peso final del 3º componente 5 g (ABS)/150 g (CUM) y confirmar (proceso, ver 1º componente) 	 	 
Añadir el 3º componente 		
Advertencia: el error en la pesada del 2º componente se subsana al pesar el 3º componente. El peso efectivo es de 5,5 g cuando el indicador está en 0,0.		
Confirmar la (última) pesada 	 	 
Fin del proceso de formulación. En pantalla aparece el peso final efectivo de la mezcla.		

## 6 Master Mode

Seleccione Master Mode para modificar los ajustes de la balanza y para activar las funciones.

### 6.1 Selección del Master Mode

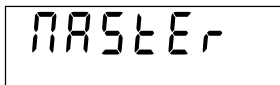

En modo Pesaje, mantenga pulsada la tecla «**Menu**» hasta que aparezca el mensaje adjunto en la pantalla.

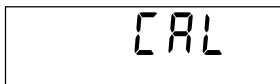
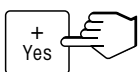

Pulse la tecla «**Yes**» antes de que pasen 3 segundos, de lo contrario la balanza retorna al modo Pesaje. A continuación accederá al primer bloque de menú de Master Mode.

### 6.2 Resumen del menú Master Mode

Manejo de Master Mode: confirme con la opción «**Yes**» o recházela con «**No**».

Pantalla/Ajustes	Función/Indicaciones
CAL	Calibrar la balanza (ver capítulo 6.3, no disponible en balanzas verificadas)
SCALE	Ajustes de la balanza
RESOLU	Seleccionar resolución (no disponible en balanzas verificadas)
0.1	"Full Range" 0 ... 7.100 g / 0,1 g (configuración de fábrica)
0.05	"Delta Range" 0 ... 999,95 g / 0,05 g, 1.000 ... 7.100 g / 0,1 g
Unit	Seleccionar unidad de pesada (no disponible en balanzas verificadas)
g	Gramo (configuración de fábrica)
oz	Onza
P	Piezas (1 pieza = 1/32 oz)
BLIGHT	Conectar/desconectar iluminación de la pantalla
On	Conectada (configuración de fábrica)
OFF	Desconectada
RESEAR	Conectar/Desconectar función de memoria automática (no disponible en balanzas verificadas)
On	Conectada
OFF	Desconectada (configuración de fábrica)
VIBRATE	Seleccionar adaptador de vibraciones
NED	Objetos de pesada normales (configuración de fábrica)
HIGH	Entorno inestable
LOW	Entorno muy estable
PROCESS	Seleccionar adaptador de proceso
NORMAL	Objetos de pesada normales
DOSING	Dosificar, p. ej. objetos en estado líquido o pulverulento (config. de fábrica)
RESET	Reposición de todos los ajustes SCALE a la configuración de fábrica
Set On	Regresar a la configuración de fábrica con « <b>Yes</b> » y rechazar con « <b>No</b> »
End SC	Abandonar el bloque "SCALE" con « <b>Yes</b> »

Pantalla/Ajustes	Función/Indicaciones
IFACE 1 / IFACE 2	Configurar interface(s)
ModE	Seleccionar tipo de operación
<b>d IALOG</b>	Comunicación con ordenador (configuración de fábrica IFACE 1)
2nd d IS	Control de pantalla auxiliar (configuración de fábrica IFACE 2)
PM	Modo de la balanza PM
Print	Comunicación con impresora
EXCLE	Impresión de datos cuando cambia el peso
Pratob	Seleccionar informe
<b>HONOFF</b>	Informe Xon/Xoff (configuración de fábrica)
NO	Ningún informe
PRR.ITY	Selección de bits y paridad
7 EVEN	7 bits de datos con paridad par
7 NO P	7 bits de datos sin paridad
<b>8 NO P</b>	8 bits de datos sin paridad (configuración de fábrica)
7 Odd	7 bits de datos con paridad impar
BRUD	Seleccionar velocidad de transferencia de datos
300	300, 600, 1.200, 2.400, 4.800, <b>9.600</b> (configuración de fábrica),
⋮	19.200 y 38.400
38400	
AutoMod	Modo automático
<b>AUTS IF</b>	El interface envía datos sin interrupción (configuración de fábrica IFACE 1)
NO	Modo automático desconectado (configuración de fábrica IFACE 2)
RESET	Reposición del ajuste IFACE a la configuración de fábrica
Std On	Regresar a la configuración de fábrica con «Yes» y rechazar con «No»
End IF 1	Abandonar bloque "IFACE1" e "IFACE2" con «Yes»
List	Imprimir ajustes Master Mode con «Yes»
End	Abandonar Master Mode con «Yes». Confirmar la pregunta "StorE?" con «Yes» para guardar los ajustes o con «No» para rechazarlos.

### 6.3 Ajuste/Calibración de la balanza (no disponible en balanzas verificadas)

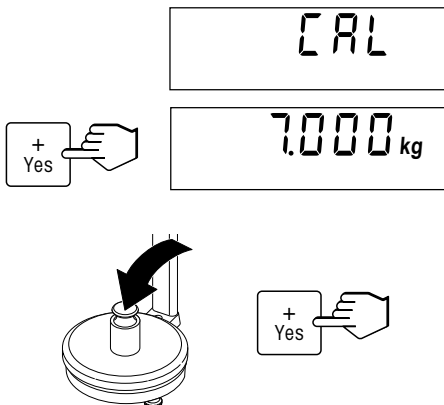

Acceda a Master Mode y seleccione "CAL".

Descargue el platillo y luego pulse la tecla «Yes» para iniciar el proceso de calibración.

La balanza muestra una señal intermitente con la pesa de calibración a depositar (de acuerdo con la carga nominal de la balanza). Para seleccionar otras pesas de calibración, pulse la tecla «No».

Deposite la pesa de calibración que se indica en pantalla y confirme con «Yes».

Advertencia: si desea **interrumpir** la calibración, **pulsación prolongada de la tecla «On/Off»**.

Espere a que aparezca el mensaje de calibración realizada con éxito (confirmación en pantalla con "done"). A continuación, la balanza regresa al modo Pesaje.

## 7 Mensajes de error

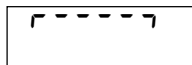

### Sobrecarga

Descargar la balanza o reducir la carga previa.

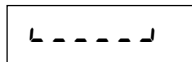

### Carga insuficiente

Colocar el platillo, garantizando que pueda moverse libremente.

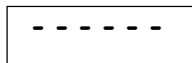

### Resultado de pesada todavía inestable

1. Lograr un entorno estable
2. Garantizar que el platillo se mueve libremente
3. Cambiar el ajuste del adaptador de vibraciones (cap. 6.2)

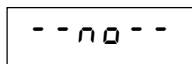

### Función no ejecutable

La función solicitada no pudo ejecutarse.

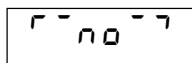

### Puesta a cero imposible (Sobrecarga/Carga insuficiente)

Asegurar que la puesta a cero se realiza sin sobrecarga o carga insuficiente.

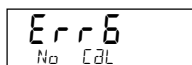
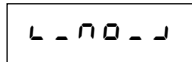

### Sin calibración/ajuste

Quitar y volver a insertar el enchufe de alimentación. Si aparece de nuevo el mensaje, calibrar/ajustar la balanza (capítulo 6.3). Si esto tampoco funciona, llamar al Distribuidor o al Servicio Técnico.

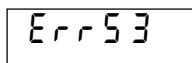

### Error en suma de prueba EARM

Quitar y volver a insertar el enchufe de alimentación. Si aparece de nuevo el mensaje, llamar al Distribuidor o al Servicio Técnico.



### Tensión baja

Tensión de salida del adaptador de red demasiado baja. Reemplazar el adaptador de red por otro con la tensión de salida correcta.



### Precisión de indicación

Introducción del valor teórico en formulación con resolución muy fina. Adapta el valor de precisión de indicación de la balanza (p. ej. entrada 15,01 g con precisión de indicación 0,05 g).

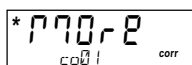

### Cantidad teórica no admisible

Cantidad teórica del componente no admisible. Redosificar hasta alcanzar la cantidad teórica.



### Formulación cancelada

Formulación cancelada con pulsación prolongada de la tecla «Last Comp».



## 8 Interfaces/ Accesorios

### 8.1 Definición de interfaces

La balanza PS7 estándar lleva incorporado un interface RS232C doble y la balanza PS7-X un interface RS232C simple. El/Los interface/s dispone/n de una clavija hembra Sub-D de 9 polos. La longitud máxima del cable es de 15 m. La configuración de los interfaces se realiza en Master Mode (ver capítulo 6.2).

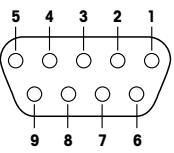
Interface(s) incorporado(s) RS232C, 9 pines D-Sub, f		Ocupación en la PS7	Ocupación en la PS7-X	2 interfaces utilizando el cable Y (accesorio), sólo en la PS7		
Ocupación				COM1	COM2	
		Pin 1	nc	nc	—	—
		Pin 2	TxD 1	TxD 1	TxD 1	TxD 2
		Pin 3	RxD 1	RxD 1	RxD 1	RxD 2
		Pin 4	nc	nc	—	—
		Pin 5	GND	GND	GND	GND
		Pin 6	nc	nc	—	—
		Pin 7	RxD 2	nc	—	—
		Pin 8	TxD 2	nc	—	—
		Pin 9	VCC (5V, ≤50mA)	nc	—	VCC (5V, ≤50mA)

TxD: enviar datos

RxD: recibir datos

GND: tierra de señales

VCC: alimentación (+5V, ≤50mA)

nc: not connected (no conectado)

### 8.2 Accesorios

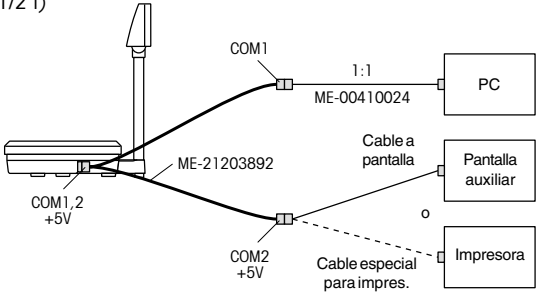
Accesorios	Nº de art.
Funda protectora (paquete de 5 unidades)	21302841
Cable Y (D-Sub 9 pines, m, COM1/2 f)  	21203892
Cable RS232 para PC 1,8m (D-Sub 9 pines, m/f, 1:1)	00410024

## 9 Datos técnicos / Directrices y normas de comprobación

### 9.1 Datos técnicos

Carga máxima	7.100 g
Precisión de indicación	Full Range: 0,1 g (0 ... 7.100 g) Delta Range: 0,05 g (0 ... 999,95 g), 0,1 g (1.000 ... 7.100 g)
Tiempo de estabilización	1,0 segundos aprox.
Linealidad	0,2 g
Alimentación de corriente	a través de adaptador de red/fuente de alimentación 13,5 VAC, 4 vatios
Unidades de pesada	g, oz y P (1 pieza= 1/32 oz)
Pantalla	LCD (de cristal líquido), retroiluminada
Condiciones ambientales	Intervalo de temperatura: +10 ... +30°C Humedad atmosférica relativa: 20 ... 80% rF (sin condensación)
Peso neto/bruto	3,4 kg / 4,5 kg
Categoría de sobretensión:	II
Grado de ensuciamiento:	2

### Medidas

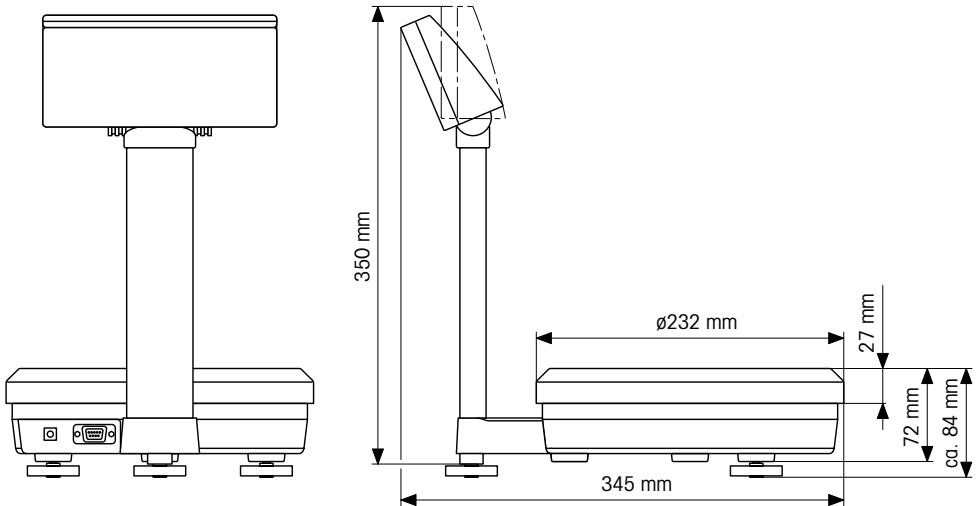



## 9.2 Directrices y normas de comprobación

### Línea de balanzas PS7

Declaramos bajo nuestra propia responsabilidad que el producto al que alude este documento cumple todas las directrices CE indicadas a continuación.

Advertencia: las balanzas verificadas/verificables disponen de un permiso de fabricación CE. El año de la primera verificación está impreso junto al símbolo CE. Estas balanzas se verifican en fábrica y llevan el distintivo «M» en el aparato y en el embalaje. Si la letra M aparece en el fondo, la balanza puede ponerse en marcha nada más montarla. Si el fondo está dividido y rayado, el servicio de mantenimiento de METTLER TOLEDO deberá verificar la balanza en su lugar de utilización. Si el plazo de validez de la verificación está limitado por las normas nacionales de cada estado, el usuario es responsable de las verificaciones posteriores reglamentarias de su balanza.

Distintivo	Directriz EC	Verificado según la norma
	73/23EEC tensión baja	EN61010-1  CAN/CSA-22.2 No. 1010.1-92
	89/336EEC EMV	EN61326-1 Clase de emisión B EN61000-3-2 Oscilaciones armónicas EN61000-3-3 Fluctuaciones de tensión EN61326-1 Inmunidad (ámbito industria) AS/NZS2064.1/2, AS/NZS3548 AS/NZS4251.1, AS/NZS4252.1
	90/384EEC <sup>1)</sup> Balanzas no automáticas	EN45501 <sup>1)</sup> Aspectos metrológicos

<sup>1)</sup> Sólo válido para balanzas verificadas

Mettler-Toledo GmbH  
Industrial BA IND-N  
Nönikon, Mai 2001

Johannes Schmid  
Director General  
Estándar Industria

Marlise Ackermann  
Director de proyecto  
Área de Producto Pesaje General

### EE.UU.

*This equipment has been tested and found to comply with the limits for a Class A digital device, pursuant to both Part 15 of the FCC Rules and the radio interference regulations of the Canadian Department of Communications. These limits are designed to provide reasonable protection against harmful interference when the equipment is operated in a commercial environment. This equipment generates, uses and can radiate radio frequency energy and, if not installed and used in accordance with the instruction manual, may cause harmful interference to radio communications. Operation of this equipment in a residential area is likely to cause harmful interference, in which case the user will be required to correct the interference at his own expense.*

### Canadá

*ICES-001 Notice for Industrial, Scientific and Medical Radio Frequency Generators: This ISM apparatus meets all requirements of the Canadian Interference-Causing Equipment Regulations. Please note that this requirement is only for generators which operate at over 10 kHz.*

*AVIS de l'ICES-001, générateurs de radiofréquences dans le domaine industriel, scientifique et médical: Cet appareil ISM (industriel, scientifique et médical) satisfait à toutes les exigences définies par la réglementation canadienne en matière d'équipements générant des perturbations radioélectriques. Veuillez noter qu'il s'agit d'une exigence concernant uniquement les générateurs fonctionnant au-delà de 10 kHz.*

**Línea de balanzas PS7-X**

Declaramos bajo nuestra propia responsabilidad que el producto al que alude este documento cumple todas las directrices CE indicadas a continuación.

Advertencia: las balanzas verificadas/verificables disponen de un permiso de fabricación CE. El año de la primera verificación está impreso junto al símbolo CE. Estas balanzas se verifican en fábrica y llevan el distintivo «M» en el aparato y en el embalaje. Si la letra M aparece en el fondo, la balanza puede ponerse en marcha nada más montarla. Si el fondo está dividido y rayado, el servicio de mantenimiento de METTLER TOLEDO deberá verificar la balanza en su lugar de utilización. Si el plazo de validez de la verificación está limitado por las normas nacionales de cada estado, el usuario es responsable de las verificaciones posteriores reglamentarias de su balanza.

Distintivo	Directriz EC	Verificado según la norma
  	94/9/EEC (ATEX)	EN50014, EN50020  FMRC 3600, 3610, 3810  CSA-C22.2 No. 157-92 CSA-C22.2 No. 142-M 1987
	73/23EEC tensión baja	EN60950-1
 	89/336EEC EMV	EN61326-1 Clase de emisión B EN61000-3-2 Oscilaciones armónicas EN61000-3-3 Fluctuaciones de tensión EN61326-1 Inmunidad (ámbito industria)  AS/NZS2064.1/2, AS/NZS3548 AS/NZS4251.1, AS/NZS4252.1

Mettler-Toledo GmbH  
 Industrial BA IND-N  
 Nänikon, Mai 2001

Johannes Schmid  
 Director General  
 Estándar industria

Marlise Ackermann  
 Director de proyecto  
 Área de Producto Pesaje General

**EE.UU.**

*This equipment has been tested and found to comply with the limits for a Class A digital device, pursuant to both Part 15 of the FCC Rules and the radio interference regulations of the Canadian Department of Communications. These limits are designed to provide reasonable protection against harmful interference when the equipment is operated in a commercial environment. This equipment generates, uses and can radiate radio frequency energy and, if not installed and used in accordance with the instruction manual, may cause harmful interference to radio communications. Operation of this equipment in a residential area is likely to cause harmful interference, in which case the user will be required to correct the interference at his own expense.*

**Canadá**

*ICES-001 Notice for Industrial, Scientific and Medical Radio Frequency Generators: This ISM apparatus meets all requirements of the Canadian Interference-Causing Equipment Regulations. Please note that this requirement is only for generators which operate at over 10 kHz.*

*Avis de l'ICES-001, générateurs de radiofréquences dans le domaine industriel, scientifique et médical: Cet appareil ISM (industriel, scientifique et médical) satisfait à toutes les exigences définies par la réglementation canadienne en matière d'équipements générant des perturbations radioélectriques. Veuillez noter qu'il s'agit d'une exigence concernant uniquement les générateurs fonctionnant au-delà de 10 kHz.*

# 1 Introduzione

## 1.1 Generale

Vi ringraziamo per aver scelto una **bilancia per vernici PS7 o la sua versione antideflagrante PS7-X**. Con la PS7/PS7-X si possono pesare i componenti di una miscela avendone stabilito in precedenza le proporzioni. La bilancia possiede diverse modalità di correzione al fine di riequilibrare i componenti che sono stati eventualmente dosati in modo errato. Attraverso l'interfaccia incorporata RS232 la bilancia può essere connessa a una stampante oppure collegata a un computer o a un secondo display.

Vi preghiamo di leggere attentamente queste istruzioni per l'uso e di attenervi alle disposizioni!

## 1.2 Sicurezza e ambiente



- **Non usare la bilancia PS7 in un ambiente a rischio di esplosioni** (in presenza di miscele esplosive di gas, vapori, fumi e polveri).

Per le **zone a rischio di esplosioni** si utilizzi la bilancia **PS7-X**. Queste bilance devono essere **assolutamente** collegate **tramite l'alimentatore certificato** di METTLER TOLEDO. Le indicazioni contenute nelle istruzioni per l'installazione e il collegamento all'alimentatore si devono osservare e seguire rigorosamente. A causa del pericolo di cariche elettrostatiche l'impiego di una capottina di protezione in zone a rischio di esplosioni è permesso solo se questo è composto da materiale sicuramente non soggetto a cariche statiche.

- Collegare la bilancia alla corrente **esclusivamente con l'adattatore di rete (PS7)** compreso nella confezione o con **l'alimentatore (PS7-X)**. Assicurarsi che il valore della tensione impresso coincida con quello della rete locale. Controllare regolarmente i cavi dell'adattatore di rete/alimentatore. Se i cavi o l'adattatore di rete/alimentatore sono danneggiati, la bilancia non deve più essere messa in funzione.
- Utilizzare solo gli accessori e le periferiche consigliati.
- Maneggiare la bilancia con cura, si tratta di uno strumento di precisione. Urti contro il piatto e sovraccarichi eccessivi danneggiano la bilancia.
- **Scollegare la bilancia dalla corrente prima di cominciare la pulizia!**

Pulizia: utilizzare panni umidi (non usare acidi, soluzioni o solventi). Nel caso di uno sporco più resistente rimuovere il piatto della bilancia, la capottina di protezione (se disponibile) e i piedini regolabili (solo per bilance approvate) e pulirli separatamente. Attenersi alle disposizioni aziendali e alle norme specifiche del settore riguardo agli intervalli di pulizia ed ai detersivi ammessi.

- Per lo smaltimento della bilancia attenersi alle norme ambientali vigenti.

## 1.3 Avvertenze inerenti i modelli approvati

Nei modelli approvati, sono disattivate le seguenti funzioni:

- ricetta (pesate con fattore di moltiplicazione e ricetta con correzione)
- cambio dell'unità di pesata (nelle bilance approvate l'unità di pesata impostata per default è "g")
- calibrazione (i modelli approvati devono essere regolati/calibrati ad opera di un centro di assistenza postvendita autorizzato METTLER TOLEDO)

## 2 Messa in funzione

### 2.1 Installazione e livellamento della bilancia

La giusta posizione contribuisce in modo decisivo alla precisione dei risultati di pesata.

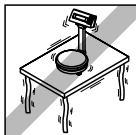

Scegliete una posizione stabile, priva di oscillazioni e possibilmente orizzontale.



Non richiudete mai con un martello le latte di vernice che si trovano ancora sul piatto della bilancia.



Evitate sbalzi di temperatura eccessivi e l'esposizione diretta ai raggi del sole. Fate attenzione alle condizioni ambientali.

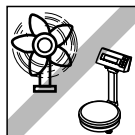

Evitate le correnti d'aria (per esempio di ventilatori o condizionatori d'aria).

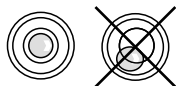

**Solo per bilance omologate:** Ruotate i piedini regolabili e disponete la bilancia in posizione orizzontale. La bolla d'aria deve trovarsi nel cerchio interno. Attenzione: le bilance omologate devono essere regolate sul posto da un centro servizi METTLER TOLEDO autorizzato.

### Grandi cambiamenti di posizione geografica

Vi suggeriamo di calibrare la bilancia per la prima messa in funzione (vedi capitolo 6.3). Le bilance omologate devono essere calibrate secondo le norme nazionali di omologazione direttamente sul luogo di utilizzo.

### 2.2 Collegamento all'alimentazione di corrente

**PS7-X per zone a rischio di esplosione:** Le bilance PS7-X per zone a rischio di esplosione possono essere collegate solo attraverso un alimentatore certificato. Osservate quindi e seguite assolutamente le disposizioni contenute nelle istruzioni separate per il collegamento all'alimentatore.

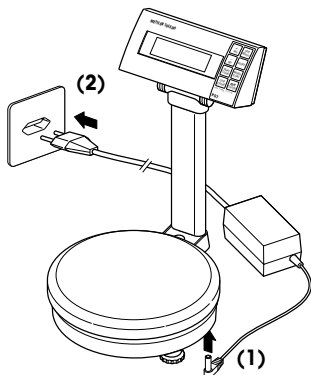









**Attenzione!** Prima di collegare l'adattatore di rete verificate che il valore della tensione impresso coincida con la tensione della rete locale.

**Importante!** per prima cosa collegare l'adattatore di rete con la presa posta sulla parte sottostante della bilancia (1). Solo successivamente infilare la spina dell'adattatore di rete nella presa (2).

Dopo il collegamento la bilancia esegue un test del display, durante il quale tutti i segmenti e successivamente le versioni software vengono visualizzate brevemente. Non appena comparirà l'indicatore di zero la bilancia sarà pronta per il funzionamento.

### 3 Tasti funzione

Tasti	Funzioni	
	premere brevemente	tenere premuto
	Tarare la bilancia **	Accendere o spegnere la bilancia **
	Scegliere il fattore di conversione, per dosare una quantità maggiore o minore di una ricetta	Riportare il fattore di conversione su "1" (pesata senza fattore)
	Modificare l'unità di misura	Entrare nella modalità Master ** (vedi capitolo 6.1)
	Confermare il peso desiderato di un componente dosato e procedere con il componente successivo	—
	Confermare il peso desiderato dell'ultimo componente dosato di una ricetta	Interrompere il processo di esecuzione della ricetta
	Scegliere il metodo di esecuzione della ricetta o la tolleranza. <b>Modalità di esecuzione della ricetta avanzata</b> Impostare la cifra seguente del peso desiderato	Confermare il metodo di esecuzione della ricetta o la tolleranza scelti <b>Modalità di esecuzione della ricetta avanzata</b> Confermare il peso desiderato inserito
	La funzione dipende dalla modalità di lavoro in atto <b>Modalità Master **</b> Confermare l'impostazione attuale <b>Modalità di esecuzione della ricetta standard</b> Aumentare il valore teorico del componente <b>Modalità di esecuzione della ricetta avanzata</b> Aumentare il valore teorico del componente	<b>Modalità Master</b> — <b>Modalità di esecuzione della ricetta standard</b> Aumentare di 1.0 il valore teorico del componente <b>Modalità di esecuzione della ricetta avanzata</b> —
	La funzione dipende dalla modalità di lavoro in atto <b>Modalità Master **</b> Cancellare l'impostazione attuale <b>Modalità di esecuzione della ricetta standard</b> Diminuire il valore teorico del componente <b>Modalità di esecuzione della ricetta avanzata</b> Diminuire il valore teorico del componente	<b>Modalità Master</b> — <b>Modalità di esecuzione della ricetta standard</b> Diminuire il valore teorico del componente di 1.0 (tenendo premuto il tasto, il valore diminuirà ulteriormente) <b>Modalità di esecuzione della ricetta avanzata</b> Ritornare all'ultima cifra

\*\* Nelle bilance approvate sono attivi solo i seguenti tasti

## 4 Pesare

### 4.1 Accensione / spegnimento e scelta dell'unità di misura

#### Accensione / spegnimento



Tenendo premuto il tasto «**O/T**» accendete o spegnete la bilancia.

Dopo l'accensione la bilancia esegue un test del display. Non appena compare l'indicazione di pesata, la bilancia è pronta a pesare ed è automaticamente impostata sullo zero.

#### Scelta dell'unità di misura (non disponibile nelle bilance approvate)



Premendo brevemente il tasto «**Unit**» si può cambiare l'unità di misura scegliendo tra "g" (Grammi), "oz" (Once) e "P" (Parti).

### 4.2 Pesata semplice

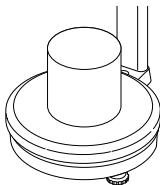

Posizionare il contenitore sulla bilancia. Per la taratura, premere brevemente il tasto «**O/T**». Comparirà l'indicazione di zero.

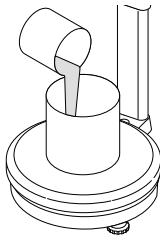

Versare la quantità desiderata del materiale da pesare.

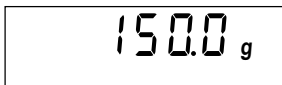

Attendere finché il rilevatore automatico di stabilità (simbolo circolare sul display) si spegne e compaiono i risultati di pesata.



## 5 Esecuzione della ricetta

Nota: **Nelle bilance approvate le funzioni di ricetta sono disattivate** (pesata con fattore di moltiplicazione, ricetta con correzione).

### 5.1 Scelta del fattore

Per dosare una quantità maggiore o minore di una data ricetta, si può scegliere un fattore (moltiplicatore).

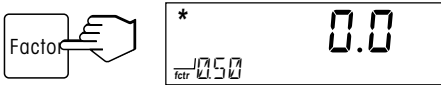

**Premendo brevemente** il tasto «Factor» attiverete la pesata a fattore.

Sul display in basso a sinistra compare il fattore utilizzato per l'ultima pesata a fattore (per esempio 0.50).

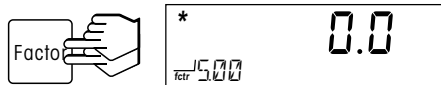

Premete **brevemente** il tasto «Factor» **per più volte di seguito**, finché compare il fattore desiderato (0.20 ... 5.00).

Con la pesata successiva viene dosato il peso desiderato (per es. 1000 g) di un componente in base alla ricetta. In funzione del fattore selezionato viene quindi dosata una quantità effettiva minore o maggiore di un fattore.

**Esempio 1:** Peso in base alla ricetta 1000 g, fattore selezionato 0.50 (per una quantità dimezzata). Indicazione: 1000, dosaggio effettivo: 500 g

**Esempio 2:** Peso in base alla ricetta 1000 g, fattore selezionato 3.00 (per la quantità tripla). Indicazione: 1000, dosaggio effettivo: 3000 g



**Disattivazione della pesata a fattore: tenendo premuto** il tasto «Factor» disattivate la pesata a fattore.

L'indicazione del fattore scompare e il fattore viene riportato a 1.

## 5.2 I diversi metodi di esecuzione della ricetta

La PS7 offre diversi metodi di esecuzione della ricetta. Ciascun metodo si compone di:

- la **modalità di esecuzione della ricetta**:
  - **"STJ" esecuzione standard**: in questa modalità viene dosata e confermata la quantità desiderata di un componente. Nel caso di un dosaggio errato si deve immettere l'effettivo peso desiderato del componente dosato in modo errato prima di dosare il componente successivo. Dosando il componente successivo l'errore viene compensato automaticamente.
  - **"ADV" esecuzione avanzata**: in questa modalità viene prima immesso il peso desiderato di un componente. In seguito il componente viene dosato e confermato. L'eventuale errore di dosaggio viene compensato automaticamente pesando il componente successivo.
- **il tipo di indicazione**:
  - **"ABS" indicazione assoluta**: indicazione del peso assoluto di un componente.
  - **"CUM" indicazione cumulativa**: indicazione del peso accumulato.
- **la modalità di correzione**:
  - **correzione "IMM"**: correzione immediata dopo ciascun componente dosato erroneamente
  - **correzione "END"**: correzione al termine della esecuzione della ricetta

Dalla loro combinazione risultano **8 diversi metodi di esecuzione della ricetta**:

Metodo di esecuzione della ricetta	Modalità esecuz. ricetta		Tipo di indicazione		Modalità di correzione	
	Standard	Avanzata	Absoluta	Cumulativa	immediata	al termine
STJ ABS END → Cap. 5.5	X		X			X
STJ CUM END → Cap. 5.5	X			X		X
STJ ABS IMM → Cap. 5.6	X		X		X	
STJ CUM IMM → Cap. 5.6	X			X	X	
ADV ABS END → Cap. 5.7		X	X			X
ADV CUM END → Cap. 5.7		X		X		X
ADV ABS IMM → Cap. 5.8		X	X		X	
ADV CUM IMM → Cap. 5.8		X		X	X	

### 5.3 Scelta del metodo di esecuzione della ricetta



Corr P  
STD ABS END

**Premere brevemente** il tasto «**Mode**». Sul display compare l'ultimo metodo di esecuzione della ricetta selezionato (impostazione di fabbrica: "STD ABS END").



Corr P  
ADV ABS END

**Premendo brevemente** e ripetutamente il tasto «**Mode**», potete scegliere il metodo di esecuzione della ricetta desiderato (es. "ADV ABS END").

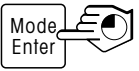

tol P  
1.5% tol adv

Confermare il metodo di esecuzione della ricetta selezionato **tenendo premuto** il tasto «**Mode**».

Nel caso in cui abbiate scelto il metodo di esecuzione avanzato ("ADV ..."), comparirà l'indicazione per la scelta della tolleranza; se la si supera i singoli componenti devono essere corretti.



tol P  
1.5% tol adv

**Premendo brevemente** e ripetutamente il tasto «**Mode**», potete scegliere la tolleranza più/meno desiderata in % (no., 0.5 ... 15.0).

Attenzione: "no" indica una tolleranza pari a zero.

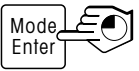

Confermare la tolleranza selezionata (es. 1.5%) **tenendo premuto** il tasto «**Mode**». Dopodiché la bilancia sarà pronta per l'esecuzione della ricetta.

**Attenzione:** Il metodo di esecuzione della ricetta selezionato rimane attivo finché non ne viene selezionato un altro.

### 5.4 Indicazioni per l'esecuzione della ricetta

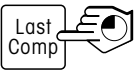

#### Interrompere l'esecuzione della ricetta

L'esecuzione di una ricetta si può interrompere in qualsiasi momento **tenendo premuto** il tasto «**Last Comp**».

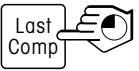

#### Stampare il protocollo di esecuzione della ricetta

Se la vostra bilancia è collegata a una stampante, potete stampare il relativo protocollo di esecuzione della ricetta **tenendo premuto** il tasto «**Last Comp**» al termine dell'operazione di esecuzione.

```
Mode :STD ABS END
Components:
co01
  target: 100.0 g
  true : 110.0 g
co02
  target: 20.0 g
  true : 22.0 g
co03
  target: 5.0 g
  true : 5.5 g
```

## 5.5 Esecuzione della ricetta con "STD ABS END" e "STD CUM END"









### Come procedere

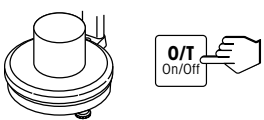
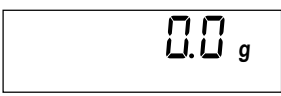
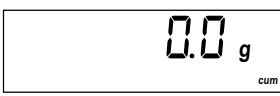



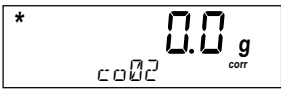

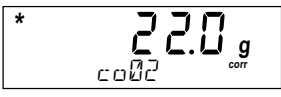



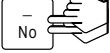









1. Posizionare il contenitore vuoto sulla bilancia e mettere in tara.
2. Dosare il componente fino a raggiungere il peso desiderato e confermare il valore con il tasto «Next Comp». Se il componente viene versato in eccesso, immettere prima il peso teorico del componente con il tasto «←» e poi confermare con il tasto «Next Comp». Attenzione: l'errore viene compensato automaticamente dosando il componente successivo. Ripetere questo passaggio finché tutti i componenti non sono dosati. Confermare l'ultimo componente con il tasto «Last Comp».
3. La bilancia verifica se i singoli componenti devono essere ulteriormente dosati. Se sì, ridosare i componenti indicati e confermare ogni volta con il tasto «Next Comp». Ripetere questo passaggio finché tutti i componenti saranno stati ridosati.

Al termine della esecuzione della ricetta la bilancia indica "done", e dopo il peso finale della miscela.

### Esempio

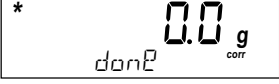
La ricetta è composta da: Componente 1: 100 g, Componente 2: 20 g, Componente 3: 5 g  
 Nessun fattore selezionato. Il componente 2 è stato dosato erroneamente (22.0 g invece di 20.0 g)

Azione	"STD ABS END"	"STD CUM END"
Posizionare e tarare il contenitore vuoto. 		
Dosare il componente 1 (Peso teorico 100 g) 		
Confermare il componente 1 		
Dosare il componente 2 (Peso teorico 20 g) 		
	Il componente 2 viene dosato in eccesso di 2 g.	

Azione	"STD ABS END"	"STD CUM END"
Immettere il valore teorico del componente 2: 20 g (ABS)/120 g (CUM) 		
Confermare il valore teorico 		
Dosare il componente 3 (Valore teorico 5 g) 		
Confermare il componente 3 (l'ultimo). 		
Ridosare il componente 1 di 10 g 		
Confermare la correzione 		
	Il processo di esecuzione della ricetta è terminato. Il peso finale effettivo della miscela compare sul display. 	

Attenzione: l'errore di dosaggio del componente 2 viene già compensato dosando il componente 3, ossia per il componente 3 vengono in realtà dosati 5.5 g (invece di 5.0 g). Tale sovradosaggio non viene evidenziato dal display, ossia sul display viene indicato dal valore teorico (5.0 o 125.0) come da ricetta.

Attenzione: a causa dell'errore di dosaggio del componente 2 il componente 1 deve essere ridosato di 10 g.

Il processo di esecuzione della ricetta è terminato. Il peso finale effettivo della miscela compare sul display.

## 5.6 Esecuzione della ricetta con "STD ABS IMM" e "STD CUM IMM"







### Come procedere



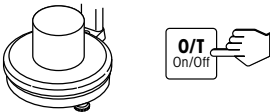
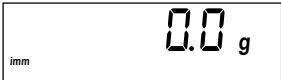
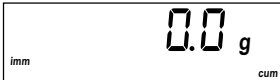



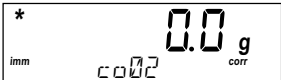

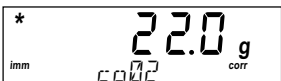
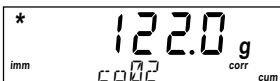

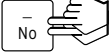

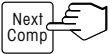

1. Posizionare il contenitore vuoto sulla bilancia e mettere in tara.
2. Dosare il componente fino a raggiungere il peso desiderato e confermare il valore con il tasto «Next Comp». Se il componente viene versato eccessivamente, immettere prima il peso teorico del componente con il tasto «←» e confermare con il tasto «Next Comp». L'errore viene compensato automaticamente dosando il componente successivo.
3. La bilancia verifica dopo ogni componente se è necessario ridosare. Se sì, ridosare i componenti indicati e confermare ogni volta con il tasto «Next Comp». Ripetere questo passaggio finché tutti i componenti saranno stati ridosati.
4. Ripetere i punti 2 e 3 finché tutti i componenti saranno stati ridosati e confermare l'ultimo componente con il tasto «Last Comp».

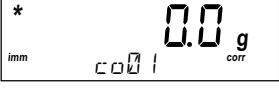
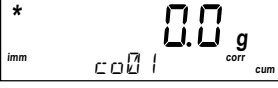
Al termine della esecuzione della ricetta la bilancia indica "done", e dopo il peso finale della miscela.

### Esempio

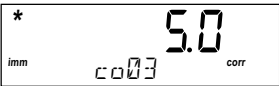
La ricetta è composta da: Componente 1: 100 g, Componente 2: 20 g, Componente 3: 5 g  
 Nessun fattore selezionato. Il componente 2 è stato dosato erroneamente (22.0 g invece di 20.0 g)

Azione	"STD ABS IMM"	"STD CUM IMM"
Posizionare e tarare il contenitore vuoto. 		
Dosare il componente 1 (Peso teorico 100 g) 		
Confermare il componente 1 		
Dosare il componente 2 (Peso teorico 20 g) 		
	Il componente 2 viene dosato in eccesso di 2 g.	

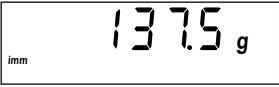
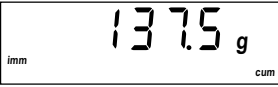
Azione	"STD ABS IMM"	"STD CUM IMM"
Immettere il valore teorico del componente 2: 20 g (ABS)/120 g CUM) 		
Confermare il valore teorico 		
Ridosare di 10 g il componente 1 		
Confermare la correzione 		
Dosare il componente 3 (Valore teorico 5 g) 		
Confermare il componente 3 (l'ultimo) 		
		

Attenzione: A causa dell'errore di dosaggio del componente 2, il componente 1 deve essere dosato nuovamente di 10 g.

Attenzione: l'errore di dosaggio del componente 2 viene già compensato dosando il componente 3, ossia in realtà vengono dosati 5.5 g (invece di 5.0 g) per il componente 3. Tale sovradosaggio non viene evidenziato dal display, ossia sul display viene indicato dal valore teorico (5.0 o 125.0) come da ricetta.

Il processo di esecuzione della ricetta è terminato. Il peso finale effettivo della miscela compare sul display.

## 5.7 Esecuzione della ricetta con "ADV ABS END" e "ADV CUM END"

### Come procedere

1. Posizionare il contenitore vuoto sulla bilancia e mettere in tara.
2. Premere il tasto «**Next Comp**» per cominciare la esecuzione di una ricetta.
3. Immettere il peso desiderato del componente indicato per cifre (impostare la cifra con il tasto «+» o «-» e confermare la cifra impostata premendo brevemente il tasto «**Enter**»). Confermare il peso desiderato immesso tenendo premuto il tasto «**Enter**».
4. Dosare il componente sullo zero e confermare il dosaggio (anche in caso di sovradosaggio) con il tasto «**Next Comp**». Se il componente è stato versato in eccesso, l'errore viene compensato automaticamente versando i componenti successivi.
5. Ripetere i passaggi 3 e 4, finché non sono stati dosati tutti i componenti. Confermare l'ultimo componente con il tasto «**Last Comp**».
6. La bilancia verifica se i singoli componenti devono essere nuovamente dosati. Se sì, dosare nuovamente i componenti e confermare ogni volta con il tasto «**Next Comp**».







Ripetere questo passaggio finché non sono stati nuovamente dosati tutti i componenti.

Terminata la esecuzione della ricetta, la bilancia indicherà "done", e dopo il peso finale della miscela.

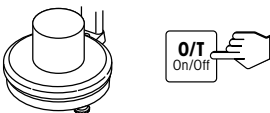





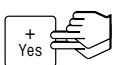
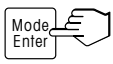
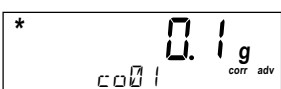
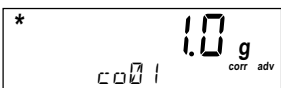
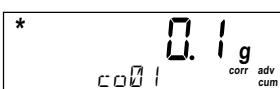
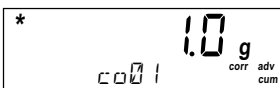



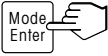

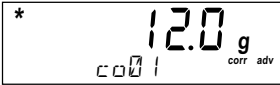





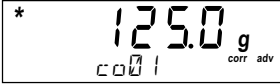





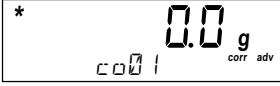

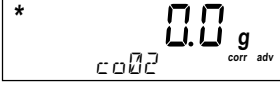
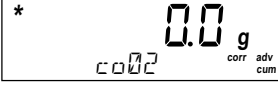
### Esempio





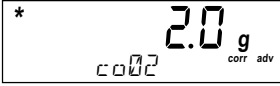
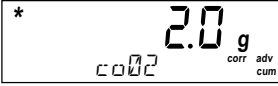





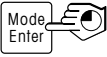
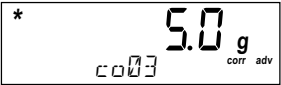
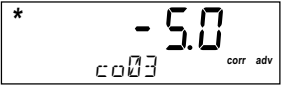

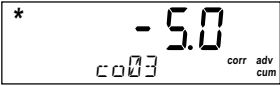
La ricetta è composta da: Componente 1: 125 g, Componente 2: 20 g, Componente 3: 5 g

Nessun fattore, nessuna tolleranza selezionati. Il componente 2 è stato dosato in eccesso (22.0 g invece di 20.0 g)

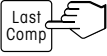
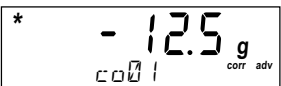
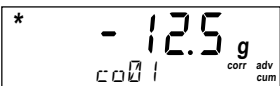
Azione	"ADV ABS END"	"ADV CUM END"
Posizionare e tarare il contenitore vuoto 		
Avviare la esecuzione della ricetta 		
Immettere per cifre il peso desiderato del componente 1 (125 g) 1° cifra  	 	 

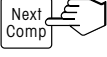

Azione	"ADV ABS END"	"ADV CUM END"
2° cifra  	 	 
3° Cifra  	 	 
Confermare il peso desiderato immesso 		
Versare il componente 1 		
Confermare il dosaggio 		
Immettere per cifre e confermare il peso desiderato del componente 2 20 g (ABS)/145 g (CUM) (Procedere come per il componente 1) 	 	 
Versare il componente 2 	 Il componente 2 viene dosato in eccesso di 2 g	
Confermare il dosaggio 		

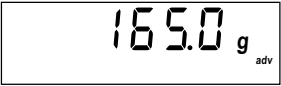
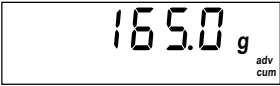
Azione	"ADV ABS END"	"ADV CUM END"
<p>Immettere per cifre e confermare il peso desiderato del componente 3 5 g (ABS)/150 g (CUM) (Procedere come per il componente 1)</p> 	 	 
<p>Versare il componente 3</p> 		 <p>Attenzione: L'errore di dosaggio del componente 2 viene compensato dosando il componente 3. Il display indica quindi 0.0, ma in realtà vengono dosati 5.5 g.</p>
<p>Confermare il dosaggio (l'ultimo)</p> 		 <p>Attenzione: A causa dell'errore di dosaggio del componente 2, il componente 1 deve essere dosato nuovamente di 12.5 g.</p>
<p>Ridossare di 12.5 g il componente 1.</p> 		
<p>Confermare il nuovo dosaggio</p> 		 <p>Il processo di esecuzione della ricetta è terminato. Il peso finale effettivo della miscela compare sul display.</p>  

## 5.8 Esecuzione della ricetta con "ADV ABS IMM" e "ADV CUM IMM"









### Come procedere

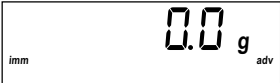

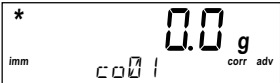



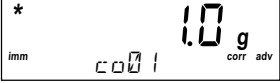

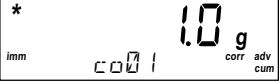

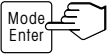





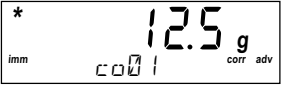

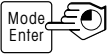
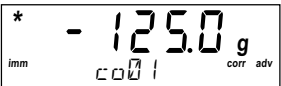
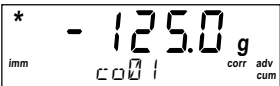

1. Posizionare il contenitore vuoto sulla bilancia e mettere in tara.
2. Premere il tasto «**Next Comp**», per cominciare la esecuzione della ricetta.
3. Immettere cifra per cifra il peso desiderato del componente indicato (impostare la cifra usando il tasto «+» o «-» e confermare l'impostazione premendo brevemente il tasto «**Enter**»). Confermare il peso desiderato premendo a lungo il tasto «**Enter**» .
4. Dosare il componente partendo dallo zero e confermare il dosaggio (anche se il componente è stato versato in eccesso) con il tasto «**Next Comp**». Se il componente è stato versato in eccesso, l'errore viene compensato automaticamente versando il componente successivo.
5. La bilancia verifica subito dopo ciascun componente se il componente precedentemente dosato deve essere dosato nuovamente. Se sì, dosare nuovamente i componenti indicati e ogni volta confermare con il tasto «**Next Comp**». Ripetere questo passaggio finché non sono stati dosati nuovamente tutti i componenti.
6. Ripetere i passaggi 3, 4 e 5, finché non sono stati dosati tutti i componenti. Confermare l'ultimo componente con il tasto «**Last Comp**».



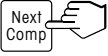

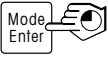

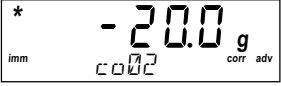

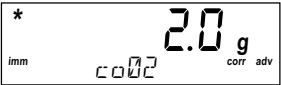
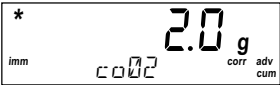

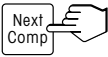
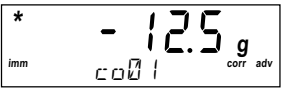
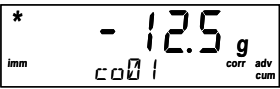

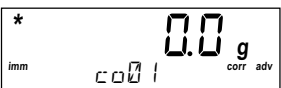
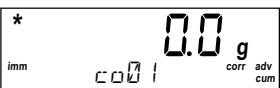
Al termine della esecuzione della ricetta la bilancia indica "done" e dopo il peso finale della miscela.

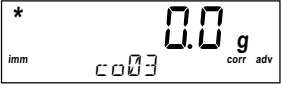
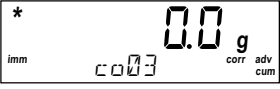
### Esempio

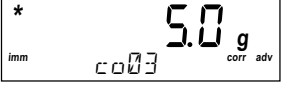
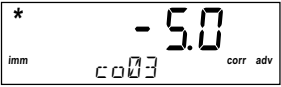
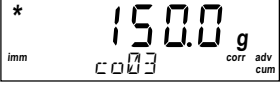
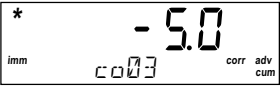
La ricetta è composta da: Componente 1: 125 g, Componente 2: 20 g, Componente 3: 5 g  
Nessun fattore, nessuna tolleranza selezionati. Il componente 2 è stato dosato in eccesso (22.0 g invece di 20.0 g)

Azione	"ADV ABS IMM"	"ADV CUM IMM"
Posizionare e tarare il contenitore vuoto 		
Avviare la esecuzione della ricetta 		
Immettere per cifre il peso desiderato del componente 1 (125 g)  Cifra 1   	  	  

Azione	"ADV ABS IMM"	"ADV CUM IMM"
Cifra 2  		
		
Cifra 3  		
		
Confermare il peso desiderato immesso 		
Versare il componente 1 		
Confermare il dosaggio 		
Immettere per cifre e confermare il peso desiderato del componente 2: 20 g (ABS)/ 145 g (CUM) (Procedere come per il componente 1) 		
		
Versare il componente 2 		
Il componente 2 viene versato in eccesso di 2 g		

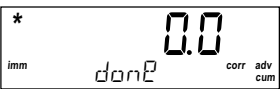
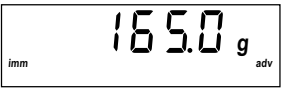
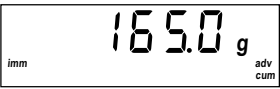
Azione	"ADV ABS IMM"	"ADV CUM IMM"
Confermare il dosaggio 		
Attenzione: A causa dell'errore di dosaggio del componente 2, il componente 1 deve essere dosato nuovamente di 12.5g.		
Dosare nuovamente il componente 1 di 12.5 g 		
Confermare il nuovo dosaggio 		
Immettere per cifre e confermare il peso desiderato del componente 3: 5 g (ABS)/ 150 g (CUM) (Procedere come per il componente 1) 	 	 
Versare il componente 3 		
Attenzione: l'errore di dosaggio del componente 2 viene compensato dosando il componente 3. Sul display compare 0.0 ma in realtà vengono dosati 5.5 g.		
Confermare il dosaggio (l'ultimo) 		
Il processo di esecuzione della ricetta è terminato. Il peso finale effettivo della miscela compare sul display.		
		

## 6 La modalità Master

Nella modalità Master si possono modificare le impostazioni della bilancia e attivare le funzioni.

### 6.1 Richiamare la modalità Master

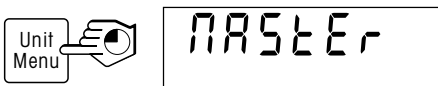

Nella modalità di pesata tenere premuto il tasto «Menu» finché non compare l'indicazione successiva.



Premere il tasto «Yes» in tre secondi (altrimenti la bilancia ritorna alla modalità di pesata). Successivamente compare il primo blocco di opzioni del menù della modalità Master.

### 6.2 Panoramica del menù della modalità Master

Condizione della modalità Master: con «Yes» si conferma l'opzione, con «No» si cancella l'opzione.

Indicazione/Impostazioni	Funzione/Note
CAL	Calibrare la bilancia (vedi capitolo 6.3, non disponibile nelle bilance approvate)
SCALE	Impostazioni della bilancia
RESOLU	Scegliere la risoluzione (non disponibile nelle bilance approvate)
0.1	"Full Range" 0 ... 7100 g / 0.1 g (Impostazioni di fabbrica)
0.05	"Delta Range" 0 ... 999.95 g / 0.05 g, 1000 ... 7100 g / 0.1 g
Unit	Scegliere l'unità di misura (non disponibile nelle bilance approvate)
g	Grammi (Impostazione di fabbrica)
oz	Once
P	Parti (1 Parte = 1/32 oz)
BLIGHT	Accendere/spegnere l'illuminazione del display
On	acceso (Impostazione di fabbrica)
OFF	spento
RESER	Accendere/spegnere la funzione di memoria automatica (non disponibile nelle bilance approvate)
On	accesa
OFF	spenta (Impostazione di fabbrica)
VIBRATE	Scegliere l'adattatore per le vibrazioni
NED	Ambiente normale (Impostazione di fabbrica)
NIKH	Ambiente non tranquillo
LQII	Ambiente molto tranquillo
PROCESS	Scegliere l'adattatore di processo
NORMER	Materiale da pesare normale
DOSING	Dosare, per esempio materiale liquido o in polvere (Impostazione di fabbrica)
RESET	Riportare tutte le impostazioni SCALE alle impostazioni di fabbrica
Set On	Con «Yes» riportare alle impostazioni di fabbrica, con «No» annullare
End SC	Uscire dal blocco "SCALE" con «Yes»

Indicazione/Impostazioni	Funzione/Note
IFACE 1 / IFACE 2	Configurare la/le interfaccia/e
ModE	Scegliere il tipo di funzionamento
<b>d IALOG</b>	Comunicazione con il Computer (Impostazione di fabbrica IFACE 1)
2nd.d IS	Comando del display secondario (Impostazione di fabbrica IFACE 2)
PM	Modalità bilancia PM
Print	Comunicazione con la stampante
CYCLE	Stampa dati in caso di variazione del peso
Protot	Scegliere il protocollo
<b>XONOFF</b>	Protocollo Xon/Xoff (Impostazione di fabbrica)
NO	Nessun protocollo
PARITY	Scegliere i bit e la parità
7 EVEN	7 bit di dati con parità pari
7 NO P	7 bit di dati senza parità
<b>8 NO P</b>	8 bit di dati senza parità (Impostazione di fabbrica)
7 Odd	7 bit di dati con Parità dispari
BRUD	Scegliere la velocità di trasmissione dati
300	300, 600, 1200, 2400, 4800, <b>9600</b> (Impostazione di fabbrica),
⋮	19200 e 38400
38400	
Aut.Mod	Modalità in automatico
<b>AUT.S IF</b>	L'interfaccia invia dati ininterrottamente (Impostazione di fabbrica IFACE 1)
NO	Modalità in automatico disattivata (Impostazione di fabbrica IFACE 2)
RESET	Ripartire l'impostazione IFACE alle impostazioni di fabbrica
Std On	Con «Yes» ritornare alle impostazioni di fabbrica, con «No» annullare
End IF 1	Con «Yes» uscire dal blocco "IFACE1" o "IFACE2"
List	Con «Yes» stampare le impostazioni della modalità Master
End	Con «Yes» uscire dalla modalità Master. Alla domanda "Store?" confermare con «Yes» per salvare le impostazioni o con «No» per annullarle.

### 6.3 Regolare/calibrare la bilancia (non disponibile nelle bilance approvate)

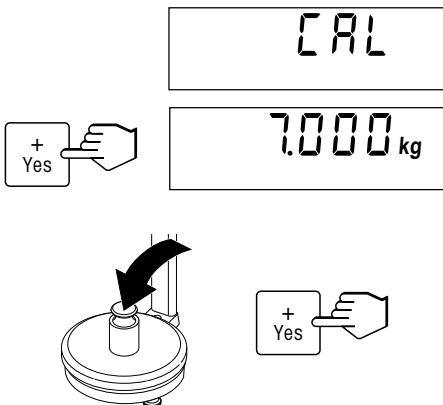

Richiamare la modalità Master e scegliere "CAL".

Svuotare il piatto della bilancia e poi premere il tasto «Yes» per avviare la procedura di calibratura.

La bilancia indica lampeggiando il peso di calibratura (corrisponde al carico nominale della bilancia). Con il tasto «No» si possono scegliere altri pesi di calibratura a piacere.

Disporre il peso di calibratura secondo l'indicazione e confermare con «Yes».

Attenzione: la calibratura si può interrompere in ogni momento **premendo a lungo il tasto «On/Off»**.

Attendere finché la calibratura non si sia conclusa con esito positivo (sul display appare la conferma con "done") e la bilancia non sia ritornata alla modalità di pesata.

## 7 Messaggi di errore

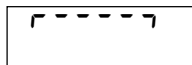

### Sovraccarico

Scaricare la bilancia o diminuire il precarico.

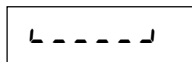

### Sottocarico

Disporre il piatto della bilancia e accertarsi che sia libero di muoversi.

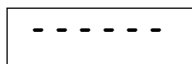

### Il risultato della pesata non raggiunge la stabilità

1. Fare in modo che l'ambiente sia tranquillo
2. Disporre il piatto della bilancia e accertarsi che sia libero di muoversi.
3. Modificare l'impostazione dell'adattatore di vibrazioni (Cap. 6.2)

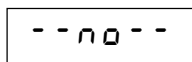

### Funzione non eseguita

Non si è potuto eseguire la funzione richiamata.

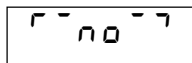

### Impossibile azzerare (Sovraccarico/Sottocarico)

Assicurarsi che l'azzeramento non venga eseguito con sovraccarico o sottocarico.

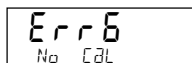
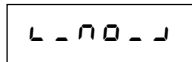

### Nessuna calibratura/regolazione

Staccare e reinserire la spina di rete. Se il messaggio ricompare, calibrare/regolare la bilancia (Capitolo 6.3). Se non si ottiene alcun effetto, contattare il fornitore o il rappresentante.

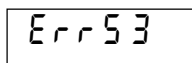

### EAROM Errore della somma di controllo

Staccare e reinserire la spina di rete. Se il messaggio ricompare, contattare il fornitore o il rappresentante.

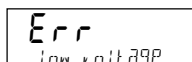

### Sottotensione

La tensione di uscita dell'adattatore di rete è troppo bassa. Sostituire l'adattatore di rete con un altro adattatore con tensione di uscita corretta.



### Risoluzione

Immissione del valore teorico durante la esecuzione della ricetta insieme a una risoluzione troppo precisa. Conformare alla bilancia il valore della precisione di lettura (per esempio se il dato è 15.01 g con una precisione di lettura di 0.05 g).

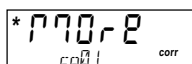

### Quantità teorica non raggiunta

Quantità teorica del componente non ancora raggiunta. Ridosare finché non la si ottiene.

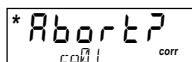

### Esecuzione della ricetta interrotta

La esecuzione della ricetta è stata interrotta premendo a lungo il tasto «Last Comp».



## 8 Interfacce/Accessori

### 8.1 Definizione delle interfacce

La bilancia standard PS7 è fornita di una interfaccia RS232C doppia mentre la PS7-X è fornita di una interfaccia RS232C singola. La/e interfaccia/e sono utilizzabili con una presa Sub-D a 9 poli. La lunghezza massima del cavo è di 15 m. La configurazione delle interfacce si realizza nella modalità Master (vedi capitolo 6.2).

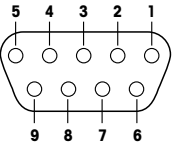
Interfaccia (e) incorporata (e) RS232C, 9-pin D-Sub, f		Occupazione in PS7	Occupazione in PS7-X	2 interfacce utilizzando il cavo Y (Accessorio), solo per la PS7 COM1		COM2
<b>Occupazione</b>	Pin 1	nc	nc	—	—	—
	Pin 2	TxD 1	TxD 1	TxD 1	TxD 2	TxD 2
	Pin 3	RxD 1	RxD 1	RxD 1	RxD 2	RxD 2
	Pin 4	nc	nc	—	—	—
	Pin 5	GND	GND	GND	GND	GND
	Pin 6	nc	nc	—	—	—
	Pin 7	RxD 2	nc	—	—	—
	Pin 8	TxD 2	nc	—	—	—
	Pin 9	VCC (5V, ≤50mA)	nc	—	—	VCC (5V, ≤50mA)

TxD: Invio dati

RxD: Ricezione dati

GND: Massa del segnale

VCC: Alimentazione (+5V, ≤50mA)

nc: Not connected (non collegato)

### 8.2 Accessori

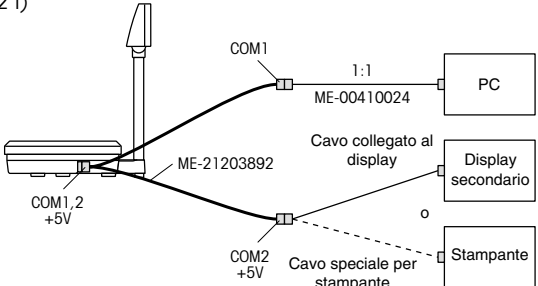
Accessorio	N° art.
Capottina di protezione (Set da 5 pz.)	21302841
Cavo Y (9-pin D-Sub, m, COM1/2 f)  	21203892
Cavo RS232 per PC 1,8m (9-pin D-Sub, m/f, 1:1)	00410024

## 9 Dati tecnici / Direttive e norme

### 9.1 Dati tecnici

Capacità	7100 g	
Risoluzione	Full Range: 0.1 g (0 ... 7100 g) Delta Range: 0.05 g (0 ... 999.95 g), 0.1 g (1000 ... 7100 g)	
Tempo di stabilizzazione	ca. 1.0 secondi	
Linearità	0.2 g	
Alimentazione	con adattatore di rete/alimentatore 13.5 VAC, 4 Watt	
Unità di misura	g, oz e P (1 Parte = 1/32 oz)	
Display	LCD (display a cristalli liquidi), con retroilluminazione	
Condizioni ambientali	Campo di temperatura:	+10 ... +30°C
	Umidità relativa dell'aria:	20 ... 80% rF (senza condensa)
Peso netto/lordo	3.4 kg / 4.5 kg	
Categoria di sovratensione:	II	
Grado di inquinamento:	2	

### Ingombri

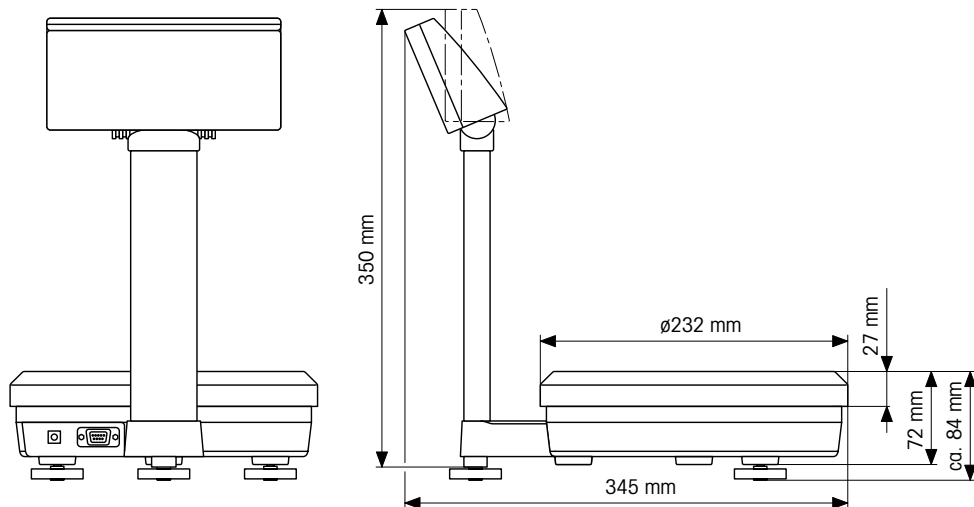



## 9.2 Direttive e norme

### Bilance della linea PS7

Con la presente dichiariamo sotto la nostra responsabilità esclusiva che il prodotto al quale fa riferimento la presente dichiarazione è conforme alle direttive CE elencate di seguito.

Note: Le bilance omologate/con l'obbligo dell'omologazione sono accompagnate dal relativo certificato di omologazione CE. L'anno della prima omologazione è indicato accanto al marchio CE. Tali bilance sono tarate in fabbrica e sono contrassegnate da una «M» sullo strumento stesso e sulla confezione. Se la lettera M appare su sfondo pieno, la bilancia può essere messa in funzione subito. Se lo sfondo è suddiviso o tratteggiato, la bilancia deve essere tarata sul luogo di utilizzo dal centro assistenza autorizzato METTLER TOLEDO. Qualora le norme vigenti nei singoli stati prevedano una limitazione della validità dell'omologazione, l'utente di questo tipo di bilance è responsabile per il tempestivo rinnovo dell'omologazione.

Marchio	Direttiva CE	provato secondo la norma
	73/23EEC Bassa tensione	EN61010-1  CAN/CSA-22.2 No. 1010.1-92
	89/336EEC EMV	EN61326-1 Emissioni cl. B EN61000-3-2 Armoniche EN61000-3-3 Oscillazioni di tensione EN61326-1 Immunità (Settore industriale) AS/NZS2064.1/2, AS/NZS3548 AS/NZS4251.1, AS/NZS4252.1
	90/384EEC <sup>1)</sup> Bilance non automatiche	EN45501 <sup>1)</sup> Aspetti metrologici

<sup>1)</sup> vale solo per bilance omologate

Mettler-Toledo GmbH  
Industrial BA IND-N  
Nänikon, Mai 2001

Johannes Schmid  
General Manager  
Standard Industrial

Marlise Ackermann  
Project Manager  
Product Area General Weighing

### USA

*This equipment has been tested and found to comply with the limits for a Class A digital device, pursuant to both Part 15 of the FCC Rules and the radio interference regulations of the Canadian Department of Communications. These limits are designed to provide reasonable protection against harmful interference when the equipment is operated in a commercial environment. This equipment generates, uses and can radiate radio frequency energy and, if not installed and used in accordance with the instruction manual, may cause harmful interference to radio communications. Operation of this equipment in a residential area is likely to cause harmful interference, in which case the user will be required to correct the interference at his own expense.*

### Canada







*ICES-001 Notice for Industrial, Scientific and Medical Radio Frequency Generators: This ISM apparatus meets all requirements of the Canadian Interference-Causing Equipment Regulations. Please note that this requirement is only for generators which operate at over 10 kHz.*

*Avis de l'ICES-001, générateurs de radiofréquences dans le domaine industriel, scientifique et médical: Cet appareil ISM (industriel, scientifique et médical) satisfait à toutes les exigences définies par la réglementation canadienne en matière d'équipements générant des perturbations radioélectriques. Veuillez noter qu'il s'agit d'une exigence concernant uniquement les générateurs fonctionnant au-delà de 10 kHz.*

**Bilance della linea PS7-X**

Con la presente dichiariamo sotto la nostra responsabilità esclusiva che il prodotto al quale fa riferimento la presente dichiarazione è conforme alle direttive CE elencate di seguito.

Note: Le bilance omologate/con l'obbligo dell'omologazione sono accompagnate dal relativo certificato di omologazione CE. L'anno della prima omologazione è indicato accanto al marchio CE. Tali bilance sono tarate in fabbrica e sono contrassegnate da una «M» sullo strumento stesso e sulla confezione. Se la lettera M appare su sfondo pieno, la bilancia può essere messa in funzione subito. Se lo sfondo è suddiviso o tratteggiato, la bilancia deve essere tarata sul luogo di utilizzo dal centro assistenza autorizzato METTLER TOLEDO. Qualora le norme vigenti nei singoli stati prevedano una limitazione della validità dell'omologazione, l'utente di questo tipo di bilance è responsabile per il tempestivo rinnovo dell'omologazione.

Marchio	Direttiva CE	provato secondo la norma
  	94/9/EEC (ATEX)	EN50014, EN50020  FMRC 3600, 3610, 3810  CSA-C22.2 No. 157-92 CSA-C22.2 No. 142-M 1987
	73/23EEC Bassa tensione	EN60950-1
 	89/336EEC EMV	EN61326-1 Emissioni cl. B EN61000-3-2 Armoniche EN61000-3-3 Oscillazioni di tensione EN61326-1 Immunità (Settore industriale)  AS/NZS2064.1/2, AS/NZS3548 AS/NZS4251.1, AS/NZS4252.1

Mettler-Toledo GmbH  
 Industrial BA IND-N  
 Nänikon, Mai 2001

Johannes Schmid  
 General Manager  
 Standard Industrial

Marlise Ackermann  
 Project Manager  
 Product Area General Weighing

**USA**

*This equipment has been tested and found to comply with the limits for a Class A digital device, pursuant to both Part 15 of the FCC Rules and the radio interference regulations of the Canadian Department of Communications. These limits are designed to provide reasonable protection against harmful interference when the equipment is operated in a commercial environment. This equipment generates, uses and can radiate radio frequency energy and, if not installed and used in accordance with the instruction manual, may cause harmful interference to radio communications. Operation of this equipment in a residential area is likely to cause harmful interference, in which case the user will be required to correct the interference at his own expense.*

**Canada**

*ICES-001 Notice for Industrial, Scientific and Medical Radio Frequency Generators: This ISM apparatus meets all requirements of the Canadian Interference-Causing Equipment Regulations. Please note that this requirement is only for generators which operate at over 10 kHz.*

*Avis de l'ICES-001, générateurs de radiofréquences dans le domaine industriel, scientifique et médical: Cet appareil ISM (industriel, scientifique et médical) satisfait à toutes les exigences définies par la réglementation canadienne en matière d'équipements générant des perturbations radioélectriques. Veuillez noter qu'il s'agit d'une exigence concernant uniquement les générateurs fonctionnant au-delà de 10 kHz.*

# 1 Inleiding

## 1.1 Algemeen

Hartelijk dank voor uw aanschaf van de **Verfmengweegschaal PS7 resp. de explosieveilige variant hiervan, de PS7-X**. Met de PS7/PS7-X kunnen componenten met een vooraf vastgestelde mengverhouding ingewogen worden. De weegschaal beschikt over diverse correctiemodi, om mogelijk incorrect ingewogen componenten te compenseren. Via de ingebouwde RS232-interface kan de weegschaal op een printer worden aangesloten of met een computer of een tweede weegschaal worden verbonden.

Lees deze bedieningshandleiding zorgvuldig door en houd de aanwijzingen in acht!

## 1.2 Veiligheid en milieu



- **Gebruik de PS7-weegschaal niet in een explosiegevaarlijke omgeving** (met explosiegevaarlijke mengsels van gassen, dampen, nevels en stof).

Voor **explosiegevaarlijke zones** dient een weegschaal van het type **PS7-X te worden gebruikt**. Deze weegschalen moeten **via de gecertificeerde voeding** van METTLER TOLEDO worden aangesloten. De aanwijzingen in de installatiehandleiding van de voeding dienen te allen tijde te worden gelezen en in acht te worden genomen. Het gebruik van een beschermhoes in explosiegevaarlijke zones is vanwege het gevaar voor elektrostatische lading alleen toegestaan, wanneer de hoes uit anti-statisch materiaal bestaat.

- Sluit weegschalen **alleen met behulp van de meegeleverde netadapter (PS7)** resp. met de **Voeding (PS7-X)** aan het stroomnet aan. Zorg ervoor dat de aangegeven spanning overeenkomt met de plaatselijke netspanning. Controleer de kabels van de netadapter/voeding regelmatig. Wanneer de kabels of de netadapter/voeding beschadigd zijn, mag de weegschaal niet meer worden gebruikt.
- Gebruik alleen aanbevolen toebehoren en randapparatuur.
- Behandel de weegschaal zorgvuldig, het is immers een precisie-instrument. Schokken van de weegschaal en het plaatsen van te zware gewichten leiden tot beschadiging van de weegschaal.
- **Haal de stekker uit het stopcontact voordat u de weegschaal reinigt!**

Reinigen: gebruik vochtige doek (geen zuren, logen of oplosmiddelen). In geval van sterke vervuiling dient u de weegschaal, de beschermhoes (indien aanwezig) en de stelvoeten (alleen bij geijkte wegers) te verwijderen en apart te reinigen. Houd bedrijfsinterne en branchespecifieke voorschriften betreffende reinigingsintervallen en toegestane reinigingsmiddelen in acht.

- Houd bij het afdanken van de weegschaal de geldende milieuvoorschriften in acht.

## 1.3 Aanwijzingen voor geijkte modellen

Bij geijkte modellen zijn de volgende functies gedeactiveerd:

- Recepteren (factorwegen en recepteren met correctie)
- Wijzigen van de weegeenheid (weegeenheid bij ijkweegschalen standaard ingesteld op "g")
- Kalibreren (geijkte modellen moeten door een geautoriseerde METTLER TOLEDO serviceafdeling worden afgesteld/gekalibreerd)

## 2 Ingebruikname

### 2.1 Weegschaal plaatsen en afstellen

De juiste opstelling is van groot belang voor de nauwkeurigheid van de weegresultaten!

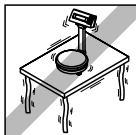

Kies stabiele, schokvrije en zo mogelijk horizontale positie.



Sluit verbussen op de weegschaal nooit met een hamer.



Vermijd overmatige temperatuurschommelingen en direct zonlicht. Houd omgevingscondities in acht.

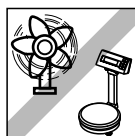

Vermijd tocht (bijv. van ventilatoren of airconditionings).



**Alleen ijkweegschaal:** Stel de weegschaal horizontaal af door de stelvoeten te verdraaien. De luchtbel moet zich binnen de cirkel bevinden.

Aanwijzing: ijkweegschalen moeten op de opstellingsplaats door een geautoriseerde METTLER TOLEDO Servicedienst afgesteld worden.

### Grotere geografische locatieveranderingen

Wij raden u aan om de weegschaal bij de eerste ingebruikname te kalibreren (zie Hoofdstuk 6.3). Ijkweegschalen moeten onder inachtneming van de landelijke ijkvoorschriften ter plaatse geïkt worden.

### 2.2 Voeding aansluiten

**PS7-X voor explosiegevaarlijke zones:** de weegschalen van het type PS7-X voor explosiegevaarlijke zones mogen alleen via een gecertificeerde voeding worden aangesloten. Lees daarom de aanwijzingen in de aparte installatiehandleiding van de voeding aandachtig en houd ze in acht.

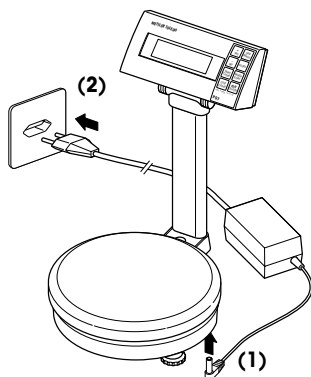

**Let op!** Controleer voordat u de netadapter aansluit of de aangegeven spanning overeenkomt met de plaatselijke netspanning.

**Belangrijk!** Verbind de netadapter eerst met de bus aan de onderzijde van de weegschaal (1). Pas daarna de stekker van de netadapter in het stopcontact steken (2).

Na het aansluiten voert de weegschaal een displaytest uit, waarbij alle segmenten en aansluitend de softwareversie kort worden weergegeven. Zodra de nulaanduiding verschijnt, is de weegschaal gereed voor gebruik.

### 3 Toetsfuncties

Toets	Functie bij	
	Kort indrukken	Lang indrukken
<b>O/T</b> On/Off	Weegschaal tarreren **	Weegschaal in- of uitschakelen **
Factor	Omrekenfactor kiezen om kleinere of grotere hoeveelheid van een recept in te wegen	Resetten van omrekenfactor naar "1" (wegen zonder factor)
Unit Menu	Wijzigen van de weegeenheid	Toegang tot de Mastermode ** (zie Hoofdstuk 6.1)
Next Comp	Bevestigen van het streefgewicht van een ingewogen component en doorgaan met de volgende component	—
Last Comp	Bevestigen van het streefgewicht van de laatst ingewogen component van een recept	Recepteerprocedure afbreken
Mode Enter	Recepteermethode of tolerantie kiezen  <b>Geavanceerd-recepteermodus</b> Volgende cijfer van streefgewicht instellen	Gekozen recepteermethode bevestigen of gekozen tolerantie bevestigen  <b>Geavanceerd-recepteermodus</b> Ingevoerd streefgewicht bevestigen
+ Yes	Functie afhankelijk van actuele gekozen bedrijfsmodus <b>Mastermode **</b> Bevestigen van actuele instelling <b>Standaard-recepteermodus</b> Streefwaarde van component verhogen <b>Geavanceerd-recepteermodus</b> Streefwaarde van component verhogen	<b>Mastermode</b> — <b>Standaard-recepteermodus</b> Streefwaarde van comp. met 1.0 verhogen <b>Geavanceerd-recepteermodus</b> —
- No	Functie afhankelijk van actuele gekozen bedrijfsmodus <b>Mastermode **</b> Verwerpen van actuele instelling <b>Standaard-recepteermodus</b> Streefwaarde van component verlagen  <b>Geavanceerd-recepteermodus</b> Streefwaarde van component verlagen	<b>Mastermode</b> — <b>Standaard-recepteermodus</b> Streefwaarde van component met 1.0 verlagen (bij ingedrukte toets wordt de waarde automatisch verder verlaagd) <b>Geavanceerd-recepteermodus</b> Terug naar laatste cijfer

\*\* Bij ijkweegschalen zijn alleen deze toetsen geactiveerd

## 4 Wegen

### 4.1 In-/uitschakelen en weegeenheid kiezen

#### In-/uitschakelen



Door de toets «**O/T**» lang in te drukken, kunt u de weegschaal in- of uitschakelen. Na het inschakelen voert de weegschaal een displaytest uit. Zodra de gewichtsaanduiding verschijnt, is de weegschaal weegbereid en automatisch op nul gesteld.

#### Weegeenheid kiezen (niet beschikbaar bij ijkweegschalen)



Door de toets «**Unit**» kort in te drukken, kan de weegeenheid worden gewisseld tussen "g" (gram), "oz" (ounce) en "P" (parts).

### 4.2 Eenvoudig wegen

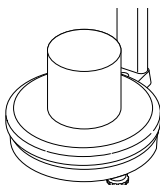

Plaats de weegbak. Om te tarreren, drukt u kort op de toets «**O/T**». De nulaanduiding verschijnt.

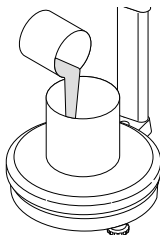

Vul de bak met de gewenste hoeveelheid van het weegproduct.

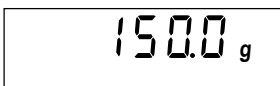

Wacht totdat de stilstandscontrole (ringsymbool op display) verdwijnt en lees het weegresultaat af.



## 5 Recepteren

Aanwijzing: **Bij ijkweegschalen zijn de recepteerfuncties gedeactiveerd** (factorwegen, recepteren met correctie).

### 5.1 Factor kiezen

Om een grotere of kleinere hoeveelheid van een bepaald recept in te wegen, kan een factor (multiplicator) worden gekozen.

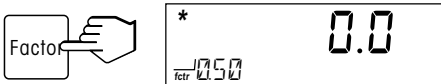

Door de toets **«Factor» kort in te drukken**, activeert u de factorweging.

In het display verschijnt links onder de bij de laatste factorweging gebruikte factor (bijv. 0.50).

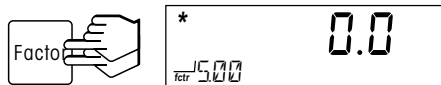

Druk aansluitend de toets **«Factor» herhaaldelijk kort in**, totdat de gewenste factor (0.20 ... 5.00) weergegeven wordt.

Bij de aansluitende weging wordt ingewogen op het streefgewicht (bijv. 1000 g) van een component volgens recept. Afhankelijk van de gekozen factor wordt echter een hoeveelheid ingewogen die de desbetreffende factor kleiner of groter is.

**Voorbeeld 1:** Gewicht volgens recept 1000 g, gekozen factor 0.50 (voor halve hoeveelheden). Weergave: 1000, daadwerkelijk ingewogen: 500 g

**Voorbeeld 2:** Gewicht volgens recept 1000 g, gekozen factor 3.00 (voor drievoudige hoeveelheid). Weergave: 1000, daadwerkelijk ingewogen: 3000 g



**Factorweging deactiveren:** Door de toets **«Factor» lang in te drukken**, deactiveert u de factorweging.

De factoraanduiding verdwijnt en de factor wordt op 1 teruggezet.

## 5.2 De verschillende recepteermethoden

De PS7 biedt verschillende recepteermethoden. Elke recepteermethode bestaat uit:

- de **recepteermodus**:
  - **“ST” Standaard recepteren**: in deze modus wordt de gewenste hoeveelheid van een component ingewogen en bevestigd. Bij onjuiste dosering dient vóór inweging van de volgende component het daadwerkelijke streefgewicht van de incorrect ingewogen component te worden ingevoerd. Bij het inwegen van volgende componenten wordt automatisch rekening gehouden met de fout.
  - **“RV” Geavanceerd recepteren**: in deze modus wordt eerst het streefgewicht van een component ingevoerd. Vervolgens wordt de component ingewogen en bevestigd. Bij inweging van volgende componenten wordt automatisch rekening gehouden met eventuele inweegfouten.
- de **weergavesoort**:
  - **“ABS” Absoluut-weergave**: weergave van het absolute gewicht van een component.
  - **“CUM” Cumulatief-weergave**: weergave van het cumulatieve gewicht.
- de **correctiemodus**:
  - **“IMM”-correctie**: correctie onmiddellijk na elke incorrect ingewogen component
  - **“END”-correctie**: correctie aan het einde van het recepteren

Via combinaties kunnen **8 verschillende recepteermethoden** worden verkregen:

Recepteermethode	Recepteermodus		Weergavesoort		Correctiemodus	
	standaard	geavanceerd	absoluut	cumulatief	onmiddellijk	aan einde
ST ABS END → Hfdst. 5.5	X		X			X
ST CUM END → Hfdst. 5.5	X			X		X
ST ABS IMM → Hfdst. 5.6	X		X		X	
ST CUM IMM → Hfdst. 5.6	X			X	X	
RV ABS END → Hfdst. 5.7		X	X			X
RV CUM END → Hfdst. 5.7		X		X		X
RV ABS IMM → Hfdst. 5.8		X	X		X	
RV CUM IMM → Hfdst. 5.8		X		X	X	

### 5.3 Recepteermethode kiezen



Druk toets **«Mode» kort in**. De als laatste gekozen recepteermethode verschijnt op het display (fabrieksinstelling: "STD ABS END").



Kies door herhaald, **kort indrukken** van de toets **«Mode»** de gewenste recepteermethode (bijv. "ADV ABS END").

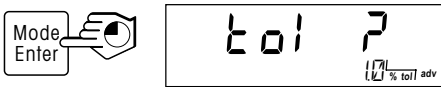

Bevestig de gekozen recepteermethode door de toets **«Mode» lang in te drukken**.

Als u een Geavanceerd-recepteermethode ("ADV ...") hebt gekozen, verschijnt de aanduiding voor de selectie van de tolerantie. Bij overschrijden van deze tolerantie moeten de afzonderlijke componenten gecorrigeerd worden.

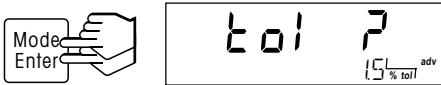

Kies door herhaald, **kort indrukken** van de toets **«Mode»** de gewenste plus/minus-tolerantie in % (no, 0.5 ... 15.0). Aanwijzing: "no" betekent een tolerantie van nul.



Bevestig de gekozen tolerantie (bijv. 1.5%) door de toets **«Mode» lang in te drukken**. De weegschaal is nu gereed voor recepteren.

**Aanwijzing:** de gekozen recepteermethode blijft geactiveerd totdat een andere methode wordt gekozen.

### 5.4 Aanwijzingen voor het recepteren



#### Recepteren afbreken

Het recepteren kan altijd worden afgebroken door de toets **«Last Comp» lang in te drukken**.



#### Recepteerverslagen afdrukken

Indien uw weegschaal is aangesloten op een printer, kan na afloop van een receptering een desbetreffend recepteerverslag worden afgedrukt door de toets **«Last Comp» lang in te drukken**.

```
Mode :STD ABS END
Components:
co01
  target: 100.0 g
  true : 110.0 g
co02
  target: 20.0 g
  true : 22.0 g
co03
  target: 5.0 g
  true : 5.5 g
```

### 5.5 Recepteren met "STD ABS END" en "STD CUM END"









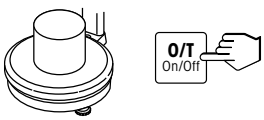

#### Procedure

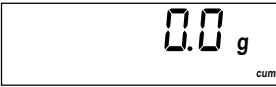



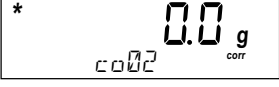

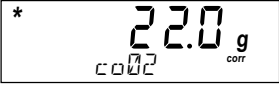

1. Plaats lege bak en tarreer.
2. Weeg componenten op het streefgewicht in en bevestig correcte inweging met de toets «Next Comp». Indien te veel componenten werden geplaatst, moet u eerst met de toets «←» het streefgewicht van de component invoeren en met de toets «Next Comp» bevestigen.  
Aanwijzing: bij het vullen van de volgende componenten wordt automatisch met deze fout rekening gehouden. Herhaal deze stap totdat alle componenten zijn ingewogen. Bevestig de laatste component met de toets «Last Comp».
3. De weegschaal controleert nu of afzonderlijke componenten opnieuw moeten worden gedoseerd. Indien ja: doseer de aangegeven componenten opnieuw en bevestig deze telkens met de toets «Next Comp». Herhaal deze stap totdat alle componenten opnieuw zijn gedoseerd.

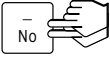
Na beëindiging van het recepteren geef de weegschaal "done" aan, daarna het eindgewicht van het mengsel.

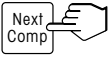
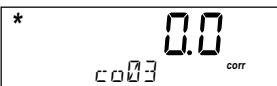
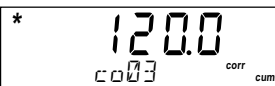
#### Voorbeeld

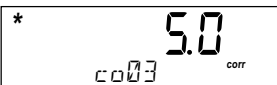
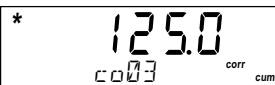
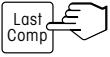
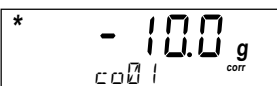
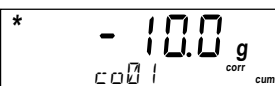
Recept bestaande uit: 1e component 100 g, 2e component 20 g, 3e component 5 g  
Geen factor gekozen. De 2e component wordt onjuist ingewogen (22,0 g i.p.v. 20,0 g)

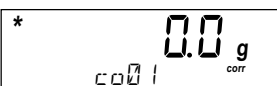
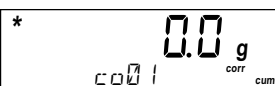
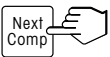
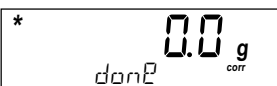
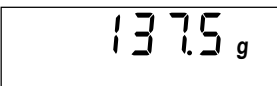
Actie	"STD ABS END"	"STD CUM END"
Plaats lege bak en tarreer 		
1e component vullen (streefwaarde 100 g) 		
1e component bevestigen 		
2e component vullen (streefwaarde 20 g) 		 <p style="text-align: center;">van 2e comp. is 2 g te veel gevuld</p>

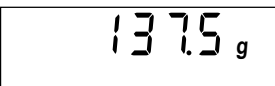
Actie	"STD ABS END"	"STD CUM END"
Voer streefwaarde voor 2e component in 20 g (ABS)/120 g (CUM) 		
Bevestig streefwaarde 		
Vul 3e component (streefwaarde 5 g) 		 Aanwijzing: de fout bij het inwegen van de 2e component wordt bij het inwegen van de 3e component gecompenseerd, d.w.z. dat voor de 3e component 5,5 g (i.p.v. 5,0 g) ingewogen. Deze overdosering vindt echter op de achtergrond plaats, d.w.z. in het display wordt de streefwaarde conform recept (5,0 resp. 125,0) getoond.
Bevestig 3e (laatste) component 		 Aanwijzing: op grond van de fout bij het inwegen van de 2e component moet van de 1e component 10 g worden bijgevoerd.
Vul 10 g van 1e component bij 		
Bevestig correctie 	 	  De recepteerprocedure wordt beëindigd. Het eindgewicht van het mengsel wordt getoond.











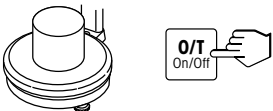

## 5.6 Recepteren met "STD ABS IMM" en "STD CUM IMM"



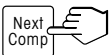







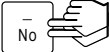

### Procedure

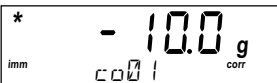
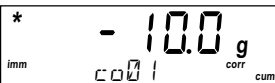
1. Plaats lege bak en tarreer.
  2. Weeg componenten op het streefgewicht in en bevestig correcte inweging met de toets «Next Comp». Indien te veel componenten werden geplaatst, moet u eerst met de toets «←» het streefgewicht van de component invoeren en met de toets «Next Comp» bevestigen. Bij het vullen van de volgende componenten wordt automatisch met deze fout rekening gehouden.
  3. De weegschaal controleert na elke component of de ingewogen componenten opnieuw moeten worden gedoseerd. Indien ja: doseer de aangegeven componenten opnieuw en bevestig deze telkens met de toets «Next Comp». Herhaal deze stap totdat alle componenten opnieuw zijn gewogen.
  4. Herhaal stap 2 en 3 totdat alle componenten zijn ingewogen. Bevestig laatste component met de toets «Last Comp».
- Na beëindiging van het recepteren geeft de weegschaal "done" aan, daarna het eindgewicht van het mengsel.

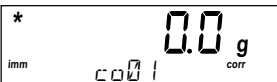
### Voorbeeld

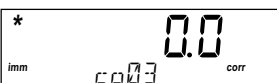
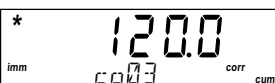
Recept bestaande uit: 1e component 100 g, 2e component 20 g, 3e component 5 g  
 Geen factor gekozen. De 2e component wordt onjuist ingewogen (22,0 g i.p.v. 20,0 g)

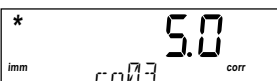
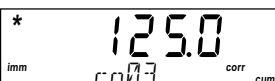
Actie	"STD ABS IMM"	"STD CUM IMM"
Plaats lege bak en tarreer 		
Vul 1e component (streefwaarde 100 g) 		
Bevestig 1e component 		
Vul 2e component (streefwaarde 20 g) 		 <p style="text-align: center;">van 2e comp. is 2 g te veel gevuld</p>

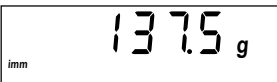
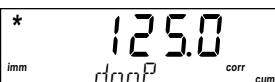
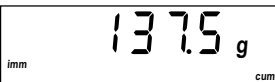
Actie	"STD ABS IMM"	"STD CUM IMM"
Voer streefwaarde voor 2e component in 20 g (ABS)/120 g CUM) 		
Bevestig streefwaarde 	 <p data-bbox="465 461 1043 512">Aanwijzing: op grond van de fout bij het inwegen van de 2e component moet van de 1e component 10 g worden bijgevuld.</p>	
Vul 10 g van 1e component bij 		
Bevestig correctie 		
Vul 3e component (streefwaarde 5 g) 		 <p data-bbox="465 924 1043 1054">Aanwijzing: de fout bij het inwegen van de 2e component wordt bij het inwegen van de 3e component gecompenseerd, d.w.z. dat voor de 3e component 5,5 g (i.p.v. 5,0 g) ingewogen. Deze overdosering vindt echter op de achtergrond plaats, d.w.z. in het display wordt de streefwaarde conform recept (5,0 resp. 125,0) getoond.</p>
Bevestig 3e (laatste) component 	 <p data-bbox="465 1174 1043 1225">De recepteerprocedure wordt beëindigd. Het eindgewicht van het mengsel wordt getoond.</p> 	 

## 5.7 Recepteren met "ADV ABS END" en "ADV CUM END"

### Procedure









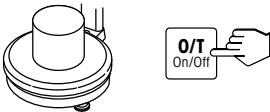

1. Plaats lege bak en tarreer.
2. Druk toets «Next Comp» in om met recepteren te beginnen.
3. Voer streefgewicht van de aangegeven component in (cijfers met toets «+» resp. «-» instellen en ingestelde cijfers bevestigen door toets «Enter» kort in te drukken). Bevestig ingevoerd streefgewicht door toets «Enter» lang in te drukken.
4. Weeg component op basis van nul in en bevestig dit (ook bij overvulling) met de toets «Next Comp». Indien van de component te veel werd gevuld, wordt de fout bij het vullen van de volgende componenten automatisch gecompenseerd.
5. Herhaal stap 3 en 4 totdat alle componenten ingewogen zijn. Bevestig laatste component met de toets «Last Comp».
6. De weegschaal controleert nu of afzonderlijke componenten opnieuw moeten worden gedoseerd. Indien ja: doseer de aangegeven componenten opnieuw en bevestig deze telkens met de toets «Next Comp».

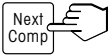
Herhaal deze stap totdat alle componenten opnieuw zijn gedoseerd.





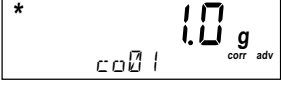

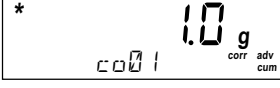



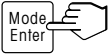

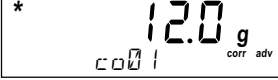

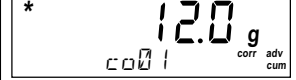

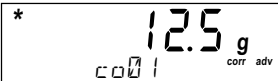

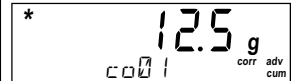

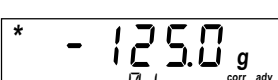
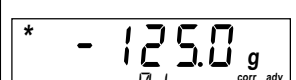





Na beëindiging van de receptering geeft de weegschaal "done" aan, daarna het eindgewicht van het mengsel.

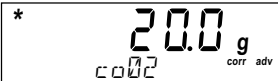
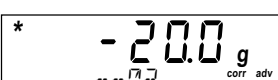

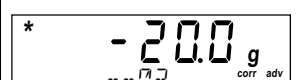

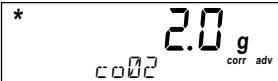

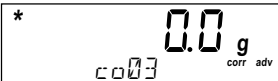





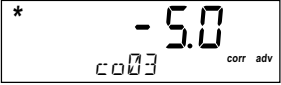

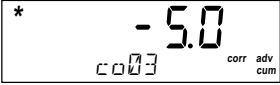
### Voorbeeld

Recept bestaande uit: 1e component 100 g, 2e component 20 g, 3e component 5 g  
 Geen factor, geen tolerantie gekozen. De 2e component wordt onjuist ingewogen (22.0 g i.p.v. 20.0 g)

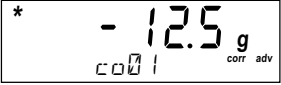
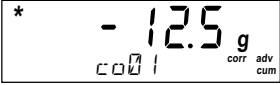
Actie	"ADV ABS END"	"ADV CUM END"
Plaats lege bak en tarreer 		
Start recepteren 		
Voer streefgewicht van 1e component (125 g) per cijfer in 1e cijfer  	 	 

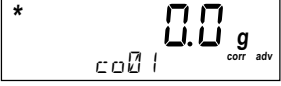
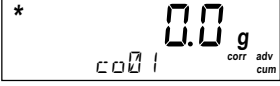
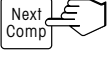

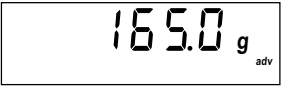
Actie	"ADV ABS END"	"ADV CUM END"
2e cijfer  	 	 
3e cijfer  	 	 
Bevestig ingevoerd streefgewicht 		
Vul 1e component 		
Bevestig inweging 		
Voer streefgewicht van 2e component 20 g (ABS)/145 g (CUM) per cijfer in en bevestig dit (zie 1e component) 	 	 
Vul 2e component 	 van 2e comp. is 2 g te veel gevuld	
Bevestig inweging 		

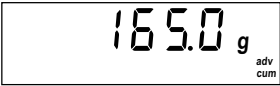
Actie	"ADV ABS END"	"ADV CUM END"
<p>Voer streefgewicht van 2e component 5 g (ABS)/150 g (CUM) per cijfer in en bevestig dit (zie 1e component)</p> 	<p>* </p> <p>* </p>	<p>* </p> <p>* </p>
<p>Vul 3e component</p> 	<p>* </p> <p>Aanwijzing: de fout bij het inwegen van de 2e component wordt bij het inwegen van de 3e component gecompenseerd. Bij de aanduiding 0.0 zijn in werkelijkheid 5,5 g ingewogen.</p>	<p>* </p>
<p>Bevestig inweging (laatste)</p> 	<p>* </p> <p>Aanwijzing: op grond van de fout bij het inwegen van de 2e component moet van de 1e component 12,5 g worden bijgevoeld.</p>	<p>* </p>
<p>Vul 12,5 g van 1e component bij</p> 	<p>* </p>	<p>* </p>
<p>Bevestig nadosering</p> 	<p>* </p> <p>De recepteerprocedure wordt beëindigd. Het eindgewicht van het mengsel wordt getoond.</p> <p></p>	<p>* </p> <p></p>

## 5.8 Recepteren met "ADV ABS IMM" en "ADV CUM IMM"





### Procedure





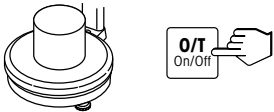
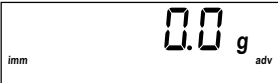
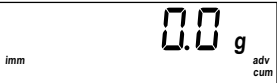

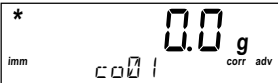

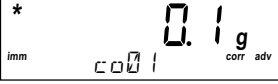
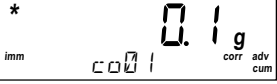
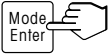
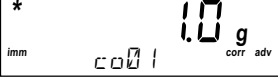
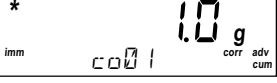
1. Plaats lege bak en tarreer.
2. Druk toets «Next Comp» in om met recepteren te beginnen.
3. Voer streefgewicht van de aangegeven component in (cijfers met toets «+» resp. «-» instellen en ingestelde cijfers bevestigen door toets «Enter» kort in te drukken). Bevestig ingevoerd streefgewicht door toets «Enter» lang in te drukken.
4. Weeg component op basis van nul in en bevestig dit (ook bij overvulling) met de toets «Next Comp». Indien van de component te veel werd gevuld, wordt de fout bij het vullen van de volgende componenten automatisch gecompenseerd.
5. De weegschaal controleert na elke component of de ingewogen componenten opnieuw moeten worden gedoseerd. Indien ja: doseer de aangegeven componenten opnieuw en bevestig deze telkens met de toets «Next Comp». Herhaal deze stap totdat alle componenten opnieuw zijn gewogen.
6. Herhaal stap 3, 4 en 5 totdat alle componenten zijn ingewogen. Bevestig laatste component met de toets «Last Comp».

Na beëindiging van het recepteren geeft de weegschaal "done" aan, daarna het eindgewicht van het mengsel.





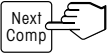





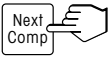
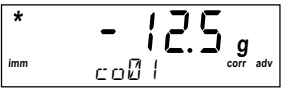
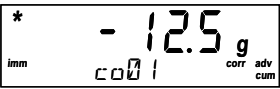

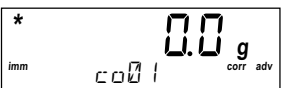
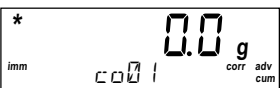
### Voorbeeld

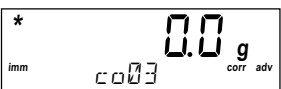
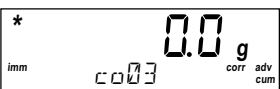
Recept bestaande uit: 1e component 125 g, 2e component 20 g, 3e component 5 g  
 Geen factor, geen tolerantie gekozen. De 2e component wordt onjuist ingewogen (22.0 g i.p.v. 20.0 g)

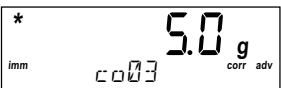
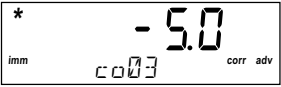
Actie	"ADV ABS IMM"	"ADV CUM IMM"
Plaats lege bak en tarreer 		
Start recepteren 		
Voer streefgewicht van 1e component (125 g) per cijfer in		
1e cijfer 		
		

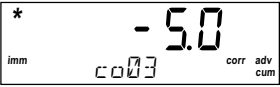
Actie	"ADV ABS IMM"	"ADV CUM IMM"
<p>2e cijfer</p>  <p>Mode Enter</p>  <p>3e cijfer</p>  <p>Mode Enter</p>  <p>Bevestig ingevoerd streefgewicht</p> 	<p>* imm 12.0 g corr adv c 0 0 1</p> <p>* imm 12.0 g corr adv c 0 0 1</p> <p>* imm 12.5 g corr adv c 0 0 1</p> <p>* imm 125.0 g corr adv c 0 0 1</p> <p>* imm - 125.0 g corr adv c 0 0 1</p>	<p>* imm 12.0 g corr adv cum c 0 0 1</p> <p>* imm 12.0 g corr adv cum c 0 0 1</p> <p>* imm 12.5 g corr adv cum c 0 0 1</p> <p>* imm 125.0 g corr adv cum c 0 0 1</p> <p>* imm - 125.0 g corr adv cum c 0 0 1</p>
<p>Vul 1e component</p> 	<p>* imm 0.0 g corr adv c 0 0 1</p>	<p>* imm 0.0 g corr adv cum c 0 0 1</p>
<p>Bevestig inweging</p> 	<p>* imm 0.0 g corr adv c 0 0 2</p>	<p>* imm 0.0 g corr adv cum c 0 0 2</p>
<p>Voer streefgewicht van 2e component 20 g (ABS)/145 g (CUM) per cijfer in en bevestig dit (zie 1e component)</p> 	<p>* imm 20.0 g corr adv c 0 0 2</p> <p>* imm - 20.0 g corr adv c 0 0 2</p>	<p>* imm 145.0 g corr adv cum c 0 0 2</p> <p>* imm - 20.0 g corr adv cum c 0 0 2</p>
<p>Vul 2e component</p> 	<p>* imm 2.0 g corr adv c 0 0 2</p>	<p>* imm 2.0 g corr adv cum c 0 0 2</p>

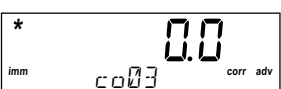
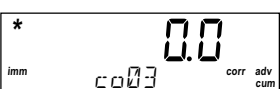
van 2e comp. is 2 g te veel gevuld

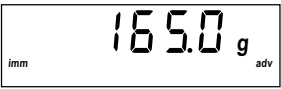
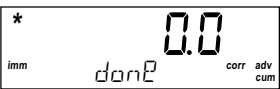
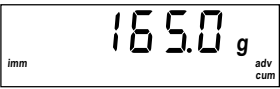
Actie	"ADV ABS IMM"	"ADV CUM IMM"
Bevestig inweging 		
Aanwijzing: op grond van de fout bij het inwegen van de 2e component moet van de 1e component 12,5 g worden bijgevoeld.		
Vul 12,5 g van 1e component bij 		
Bevestig nadosering 		
Voer streefgewicht van 2e component 5 g (ABS)/150 g (CUM) per cijfer in en bevestig dit (zie 1e component) 	 	 
Vul 3e component 		
Aanwijzing: de fout bij het inwegen van de 2e component wordt bij het inwegen van de 3e component gecompenseerd. Bij de aanduiding 0.0 zijn in werkelijkheid 5,5 g ingewogen.		
Bevestig inweging (laatste) 	 	 

## 6 De Mastermode

In de Mastermode kunt u de instellingen van de weegschaal wijzigen en functies activeren.

### 6.1 Opvragen van de Mastermode

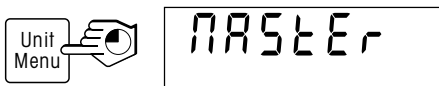

Houd in de Weegmodus de toets «**Menu**» ingedrukt, totdat de hiernaast aangegeven weergave verschijnt.



Druk binnen 3 seconden op de toets «**Yes**» (anders keert de weegschaal weer naar de Weegmodus terug). Aansluitend verschijnt het eerste menublok van de Mastermode.

### 6.2 Menuoverzicht Mastermode

Bediening van de Mastermode: bevestigen met «**Yes**», verwerpen met «**No**».

Display/instellingen	Functie/Aanwijzingen
CAL	Weegschaal kalibreren (zie Hoofdstuk 6.3, niet beschikbaar bij ijkweegschalen)
SCALE	Weegschaalinstellingen
RESOLU	Resolutie kiezen (niet beschikbaar bij ijkweegschalen)
0.1	"Full Range" 0 ... 7100 g / 0.1 g (fabrieksinstelling)
0.05	"Delta Range" 0 ... 999.95 g / 0.05 g, 1000 ... 7100 g / 0.1 g
Unit	Weegeenheid kiezen (niet beschikbaar bij ijkweegschalen)
g	Gram (fabrieksinstelling)
oz	Ounce
P	Parts (1 Part = 1/32 oz)
BLIGHT	Displayverlichting in-/uitschakelen
On	ingeschakeld (fabrieksinstelling)
OFF	uitgeschakeld
RESETR	Automatische geheugenfunctie in-/uitschakelen
(niet beschikbaar bij ijkweegschalen)	
On	ingeschakeld
OFF	uitgeschakeld (fabrieksinstelling)
VIBRATE	Vibratieadapter kiezen
NEE	normale weegproducten (fabrieksinstelling)
HIGH	onrustige omgeving
LOW	zeer rustige omgeving
PROCES	Procesadapter kiezen
UNIVER	normale weegproducten
DOSING	Doseren, bijv. van vloeibare of poedervormige weegproducten (fabrieksinstelling)
RESET	Terugzetten van alle SCALE-instellingen naar de fabrieksinstellingen
Set On	Met « <b>Yes</b> » terugzetten naar fabrieksinstelling, met « <b>No</b> » verwerpen
End SC	"SCALE"-blok verlaten met « <b>Yes</b> »

Display/Instellingen	Functie/Aanwijzingen
IFACE 1 / IFACE 2	Interface(s) configureren
ModE	Modus kiezen
<b>d IALOG</b>	Communicatie met computer (fabrieksinstelling IFACE 1)
2nd IS	Aansturing tweede display (fabrieksinstelling IFACE 2)
PN	PM-weegschaalmodus
Print	Communicatie met printer
CYCLE	Gegevens afdrukken bij wijziging gewicht
Protok	Protokol kiezen
<b>XONOFF</b>	Xon/Xoff-protokol (fabrieksinstelling)
NO	geen protokol
PRR.ITY	Bits en pariteit kiezen
7 EVEN	7 databits met even pariteit
7 NO P	7 databits zonder pariteit
<b>8 NO P</b>	8 databits zonder pariteit (fabrieksinstelling)
7 Odd	7 databits met oneven pariteit
bAUD	Baudrate kiezen
300	300, 600, 1200, 2400, 4800, <b>9600</b> (fabrieksinstelling),
⋮	19200 en 38400
38400	
AutMod	Automatische modus
<b>AUT.S IF</b>	Interface stuurt continu gegevens (fabrieksinstelling IFACE 1)
NO	Automatische modus uitgeschakeld (fabrieksinstelling IFACE 2)
RESET	Terugzetten van de IFACE-instelling naar de fabrieksinstellingen
Std On	Met «Yes» terugzetten naar fabrieksinstellingen, met «No» verwerpen
End IF 1	“IFACE1”- resp. “IFACE2”-blok verlaten met «Yes»
LIST	Met «Yes» Mastermode-instellingen afdrukken
	Met «Yes» Mastermode verlaten. Wedervraag “StorE?” met «Yes» bevestigen om instellingen op te slaan of met «No» verwerpen.

**6.3 Weegschaal kalibreren/justeren** (niet beschikbaar bij ijkweegschalen)

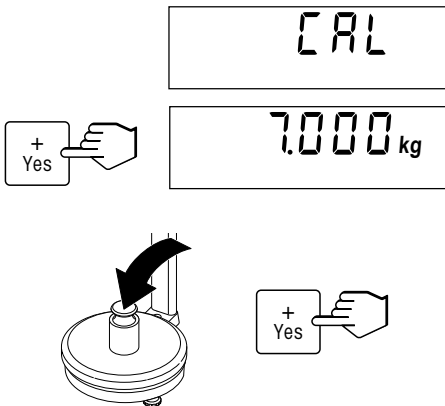

Vraag Mastermode op en kies “CAL”.

Ontlast de weegschaal en druk vervolgens op de toets «Yes» om de kalibratieprocedure te starten. De weegschaal geeft het kalibratiegewicht knipperend aan (overeenkomstig de nominale belasting van de weegschaal). Met de toets «No» kunnen desgewenst andere kalibratiegewichten worden gekozen.

Plaats kalibratiegewicht aangegeven op het display en bevestig met «Yes». Aanwijzing: Het kalibreren kan altijd worden **afgebroken door lang op de toets «On/Off» te drukken**.

Wacht totdat het kalibreren met succes is afgerond (wordt op het display aangegeven met “done”) en de weegschaal naar de Weegmodus terugkeert.

## 7 Foutmeldingen

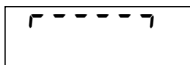

### Overbelasting

Ontlast weegschaal of verminder voorbelasting.

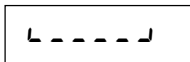

### Onderbelasting

Plaats weegplateau en zorg dat dit vrij kan bewegen.

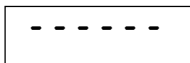

### Weegresultaat niet stabiel

1. Zorg voor een rustige omgeving
2. Zorg dat het weegplateau vrij kan bewegen
3. Wijzig de instelling van de vibratieadapter (Hfdst. 6.2)

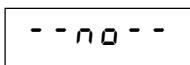

### Functie niet uitgevoerd

De opgevraagde functie kan niet worden uitgevoerd.

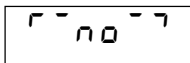

### Nulstellen niet mogelijk (overbelasting/onderbelasting)

Zorg dat nulstellen niet bij over- of onderbelasting wordt uitgevoerd.

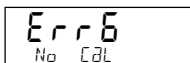
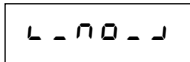

### Geen kalibratie/justering

Verwijder netstekker en steek deze weer in. Indien melding weer verschijnt, dient u de weegschaal te kalibreren/justeren (Hoofdstuk 6.3). Indien ook dit niet helpt, dient u contact op te nemen met de leverancier of de vertegenwoordiger.

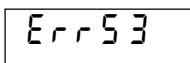

### EAROM checksum error

Verwijder netstekker en steek deze weer in. Indien melding weer verschijnt, dient u contact op te nemen met de leverancier of de vertegenwoordiger.

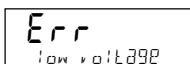

### Onderspanning

Uitgangsspanning van de netadapter te klein. Vervang netadapter door adapter met juiste uitgangsspanning.



### Afreesbaarheid

Streefwaarde met te kleine resolutie bij recepteren ingevoerd. Pas waarde van afleesnauwkeurigheid weegschaal aan (bijv. invoer 15.01 g bij afleesnauwkeurigheid 0.05 g).

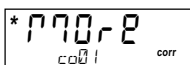

### Streefhoeveelheid nog niet bereikt

Streefhoeveelheid van de component is nog niet bereikt. Vul bij totdat streefhoeveelheid is bereikt.

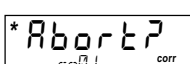

### Recepteren afgebroken

Recepteren door lang indrukken van de toets «Last Comp» afgebroken.



## 8 Interfaces /Toebehoren

### 8.1 Interface-definitie

De weegschaal PS7 is standaard uitgerust met één dubbelvoudige RS232C-interface en de PS7-X met één enkelvoudige RS232C-interface. De interface(s) zijn beschikbaar via de 9-polige Sub-D bus. De maximale kabellengte bedraagt 15 m. De configuratie van de interfaces gebeurt in de Mastermode (zie Hoofdstuk 6.2).

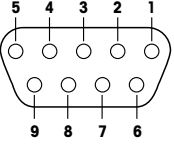
Ingebouwde interface(s) RS232C, 9-pin D-Sub, f	Toewijzing bij PS7	Toewijzing bij PS7-X	2 interfaces bij gebruik van Y-kabel (extra), alleen bij PS7		
			COM1	COM2	
<b>Toewijzing</b> 	Pin 1 Pin 2 Pin 3 Pin 4 Pin 5 Pin 6 Pin 7 Pin 8 Pin 9	nc TxD 1 RxD 1 nc GND nc RxD 2 TxD 2 VCC (5V, ≤50mA)	nc TxD 1 RxD 1 nc GND nc nc nc nc	— TxD 1 RxD 1 — GND — — — —	— TxD 2 RxD 2 — GND — — — VCC (5V, ≤50mA)

TxD: Data verzenden

RxD: Data ontvangen

GND: Signaalaaarde

VCC: Voeding (+5V, ≤50mA)

nc: not connected (niet aangesloten)

### 8.2 Toebehoren

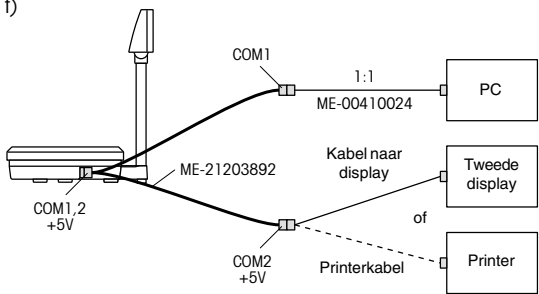
Toebehoren	Art.-nr.
Beschermhoes (set à 5 stuks)	21302841
Y-kabel (9-pin D-Sub, m, COM1/2 f)	21203892
	
RS232-kabel voor PC 1,8 m (9-pin D-Sub, m/f, 1:1)	00410024

## 9 Technische gegevens / Richtlijnen en testnormen

### 9.1 Technische gegevens

Maximale belasting	7100 g
Afreesbaarheid	Full Range: 0.1 g (0 ... 7100 g) Delta Range: 0.05 g (0 ... 999.95 g), 0.1 g (1000 ... 7100 g)
Stabilisatietijd	ca. 1.0 seconde
Lineariteit	0.2 g
Voeding	via netadapter/voeding 13.5 VAC, 4 Watt
Weegeenheden	g, oz en P (1 Part = 1/32 oz)
Display	LCD (Liquid-Crystal Display), van achteren verlicht
Omgevingscondities	Temperatuurbereik: +10 ... +30°C Relatieve luchtvochtigheid: 20 ... 80% rF (niet condenserend)
Gewicht netto/bruto	3.4 kg / 4.5 kg
Overspanningcategorie:	II
Vervuilingsgraad:	2

### Afmetingen

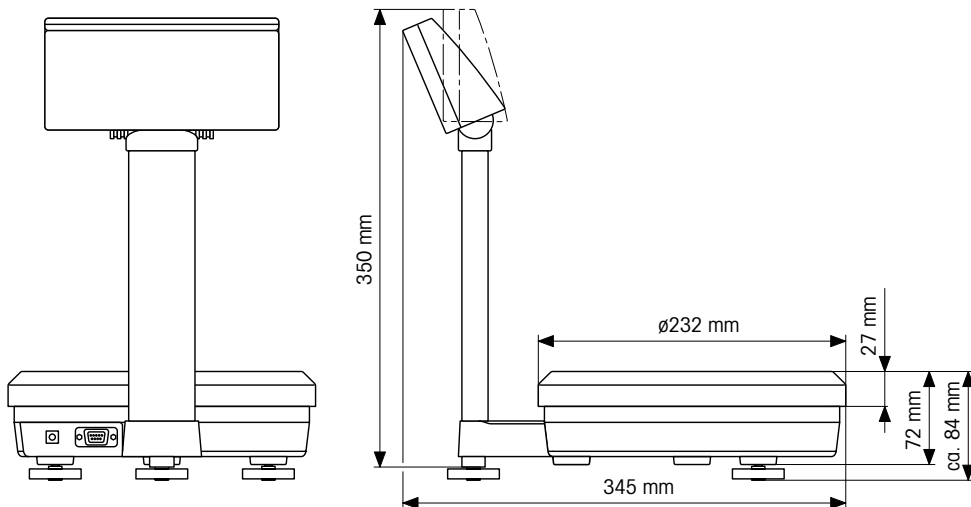







## 9.2 Richtlijnen en testnormen

### Weegschaalreeks PS7

Wij verklaren hierbij op eigen verantwoording dat het product waarop deze verklaring betrekking heeft, overeenstemt met de onderstaande EG-richtlijnen.

Aanwijzingen: voor geijkte/ijkgeschikte weegschalen is een EG-typegoedkeuring verstrekt. Naast het CE-teken staat het jaar van de eerste ijking vermeld. Deze weegschalen zijn in de fabriek geijkt en zijn voorzien van de aanduiding «M» op het apparaat zelf en op de verpakking. Wanneer de letter M op een ingekleurde achtergrond is weergegeven, mag de weegschaal direct in gebruik genomen worden. Bij een gedeelde en gearceerde achtergrond moet de weegschaal op de plaats van opstelling door de gecertificeerde METTLER TOLEDO Servicedienst ter plaatse worden geijkt. Voor zover de geldigheidsduur van de ijking conform de nationale voorschriften in de afzonderlijke landen is beperkt, is de gebruiker van een dergelijke weegschaal zelf verantwoordelijk voor een tijdige herijking.

Aanduiding	EG-richtlijn	getest conform norm
 	3/23EEC Laagspanning	EN61010-1  CAN/CSA-22.2 No. 1010.1-92
 	89/336EEC EMV	EN61326-1 Emissie Kl. B EN61000-3-2 Harmonische trillingen EN61000-3-3 Spanningsfluctuaties EN61326-1 Immunititeit(industriële toepassing) AS/NZS2064.1/2, AS/NZS3548 AS/NZS4251.1, AS/NZS4252.1
 [year] <sup>1)</sup>  [code]	90/384EEC <sup>1)</sup> Niet-zelfstandige weegschalen	EN45501 <sup>1)</sup> Metrologische aspecten

<sup>1)</sup> geldt alleen voor geijkte weegschalen

Mettler-Toledo GmbH  
Industrial BA IND-N  
Nänikon, Mai 2001

Johannes Schmid  
General Manager  
Standard Industrial

Marlise Ackermann  
Project Manager  
Product Area General Weighing

### USA

*This equipment has been tested and found to comply with the limits for a Class A digital device, pursuant to both Part 15 of the FCC Rules and the radio interference regulations of the Canadian Department of Communications. These limits are designed to provide reasonable protection against harmful interference when the equipment is operated in a commercial environment. This equipment generates, uses and can radiate radio frequency energy and, if not installed and used in accordance with the instruction manual, may cause harmful interference to radio communications. Operation of this equipment in a residential area is likely to cause harmful interference, in which case the user will be required to correct the interference at his own expense.*

### Canada







*ICES-001 Notice for Industrial, Scientific and Medical Radio Frequency Generators: This ISM apparatus meets all requirements of the Canadian Interference-Causing Equipment Regulations. Please note that this requirement is only for generators which operate at over 10 kHz.*

*Avis de l'ICES-001, générateurs de radiofréquences dans le domaine industriel, scientifique et médical: Cet appareil ISM (industriel, scientifique et médical) satisfait à toutes les exigences définies par la réglementation canadienne en matière d'équipements générant des perturbations radioélectriques. Veuillez noter qu'il s'agit d'une exigence concernant uniquement les générateurs fonctionnant au-delà de 10 kHz.*

**Weegschaalreeks PS7-X**

Wij verklaren hierbij op eigen verantwoording dat het product waarop deze verklaring betrekking heeft, overeenstemt met de onderstaande EG-richtlijnen.

Aanwijzingen: voor geijkte/ijkgeschikte weegschalen is een EG-typegoedkeuring verstrekt. Naast het CE-teken staat het jaar van de eerste ijking vermeld. Deze weegschalen zijn in de fabriek geijkt en zijn voorzien van de aanduiding «M» op het apparaat zelf en op de verpakking. Wanneer de letter M op een ingekleurde achtergrond is weergegeven, mag de weegschaal direct in gebruik genomen worden. Bij een gedeelde en gearceerde achtergrond moet de weegschaal op de plaats van opstelling door de gecertificeerde METTLER TOLEDO Servicedienst ter plaatse worden geijkt. Voor zover de geldigheidsduur van de ijking conform de nationale voorschriften in de afzonderlijke landen is beperkt, is de gebruiker van een dergelijke weegschaal zelf verantwoordelijk voor een tijdige herijking.

Aanduiding	EG-richtlijn	getest conform norm
  	94/9/EEC (ATEX)	EN50014, EN50020  FMRC 3600, 3610, 3810  CSA-C22.2 No. 157-92 CSA-C22.2 No. 142-M 1987
	73/23EEC Laagspanning	EN60950-1
 	89/336EEC EMV	EN61326-1 Emissie Kl. B EN61000-3-2 Harmonische trillingen EN61000-3-3 Spanningsfluctuaties EN61326-1 Immuniteit(industriële toepassing)  AS/NZS2064.1/2, AS/NZS3548 AS/NZS4251.1, AS/NZS4252.1

Mettler-Toledo GmbH  
Industrial BA IND-N  
Nänikon, Mai 2001

Johannes Schmid  
General Manager  
Standard Industrial

Marlise Ackermann  
Project Manager  
Product Area General Weighing

**USA**

*This equipment has been tested and found to comply with the limits for a Class A digital device, pursuant to both Part 15 of the FCC Rules and the radio interference regulations of the Canadian Department of Communications. These limits are designed to provide reasonable protection against harmful interference when the equipment is operated in a commercial environment. This equipment generates, uses and can radiate radio frequency energy and, if not installed and used in accordance with the instruction manual, may cause harmful interference to radio communications. Operation of this equipment in a residential area is likely to cause harmful interference, in which case the user will be required to correct the interference at his own expense.*

**Canada**

*ICES-001 Notice for Industrial, Scientific and Medical Radio Frequency Generators: This ISM apparatus meets all requirements of the Canadian Interference-Causing Equipment Regulations. Please note that this requirement is only for generators which operate at over 10 kHz.*

*Avis de l'ICES-001, générateurs de radiofréquences dans le domaine industriel, scientifique et médical: Cet appareil ISM (industriel, scientifique et médical) satisfait à toutes les exigences définies par la réglementation canadienne en matière d'équipements générant des perturbations radioélectriques. Veuillez noter qu'il s'agit d'une exigence concernant uniquement les générateurs fonctionnant au-delà de 10 kHz.*







**For further information** —> <http://www.e-refinish.com>

**Für weitere Informationen** —> <http://www.e-refinish.com>

**Pour de plus amples informations** —> <http://www.e-refinish.com>

**Para más información** —> <http://www.e-refinish.com>

**Per ulteriori informazioni** —> <http://www.e-refinish.com>

**Voor nadere informatie** —> <http://www.e-refinish.com>



\*P21303089\*

Subject to technical changes and to the availability of the accessories supplied with the instruments.

© Mettler-Toledo GmbH 2001 21303089A Printed in Switzerland 0110/2.47

**Mettler-Toledo GmbH**, CH-8606 Greifensee, Switzerland Tel. (01) 944 22 11, Fax (01) 944 30 60, Internet: <http://www.mt.com>

**AT Mettler-Toledo Ges.m.b.H., A-1100 Wien**, Tel. (01) 604 19 80, Fax (01) 604 28 80  
**AU Mettler-Toledo Ltd., Port Melbourne, Victoria 3207**, Tel. (03) 9644 5700, Fax (03) 9645 3935  
**BE n.v. Mettler-Toledo s.a., B-1651 Lot**, Tél. (02) 334 02 11, Fax (02) 378 16 65  
**BR Mettler-Toledo Indústria e Comércio Ltda., São Paulo, CEP 06465-130**, Tel. (11) 421 5737, Fax (11) 725 1962  
**CH Mettler-Toledo (Schweiz) AG, CH-8606 Greifensee**, Tel. (01) 944 45 45, Fax (01) 944 45 10  
**CN Mettler-Toledo Changzhou Scale Ltd., Changzhou City, Jiangsu 213001**, Tel. (519) 664 20 40, Fax (519) 664 19 91  
**CZ Mettler-Toledo, s.r.o., CZ-100 00 Praha 10**, Tel. (2) 72 123 150, Fax (2) 72 123 170  
**DE Mettler-Toledo GmbH, D-35353 Giessen**, Tel. (0641) 50 70, Fax (0641) 52 951  
**DK Mettler-Toledo A/S, DK-2600 Glostrup**, Tel. (43) 27 08 00, Fax (43) 27 08 28  
**ES Mettler-Toledo S.A.E., E-08038 Barcelona**, Tel. (93) 223 76 00, Fax (93) 223 02 71  
**FR Mettler-Toledo s.a., F-78222 Viroflay**, Tél. (01) 309 717 17, Fax (01) 309 716 16  
**HK Mettler-Toledo (HK) Ltd., Kowloon HK**, Tel. (852) 2744 1221, Fax (852) 2744 6878  
**HR Mettler-Toledo, d.o.o., CR-10010 Zagreb**, Tel. (1) 660 2189, Fax (1) 660 3009  
**HU Mettler-Toledo Kft, H-1173 Budapest**, Tel. (1) 257 9889, Fax (1) 257 7030  
**IN Mettler-Toledo India Pvt Ltd, Mumbai 400 072**, Tel. (22) 857 08 08, Fax (22) 857 50 71  
**IT Mettler-Toledo S.p.A., I-20026 Novate Milanese**, Tel. (02) 333 321, Fax (02) 356 29 73  
**JP Mettler-Toledo K.K., Shiromi, J-Osaka 540**, Tel. (6) 949 5901, Fax (6) 949 5945  
**KR Mettler-Toledo (Korea) Ltd., Seoul (135-090)**, Tel. (82) 2 518 20 04, Fax (82) 2 518 08 13  
**MY Mettler-Toledo (M) Sdn.Bhd., 40100 Shah Alam**, Tel. (603) 745 5773, Fax (603) 745 8773  
**MX Mettler-Toledo S.A. de C.V., Mexico CP 06430**, Tel. (5) 547 5700, Fax (5) 541 2228  
**NL Mettler-Toledo B.V., NL-4000 HA Tiel**, Tel. (0344) 638 363, Fax (0344) 638 390  
**NO Mettler-Toledo A/S, N-1008 Oslo**, Tel. (22) 30 44 90, Fax (22) 32 70 02  
**PL Mettler-Toledo, Sp. z o.o., PL-02-929 Warszawa**, Tel. (22) 651 92 32, Fax (22) 651 71 72  
**RU Mettler-Toledo AG, 10 1000 Moskau**, Tel. (095) 921 68 12, Fax (095) 921 63 53  
**SE Mettler-Toledo AB, S-12008 Stockholm**, Tel. (08) 702 50 00, Fax (08) 642 45 62  
**SEA Mettler-Toledo (SEA), 47301 Petaling Jaya**, Tel. (603) 704 1773, Fax (603) 703 1772  
**SG Mettler-Toledo (S) Pte. Ltd., Singapore 139959**, Tel. (65) 890 0011, Fax (65) 890 0012  
**SK Mettler-Toledo, service s.r.o., SK-83103 Bratislava**, Tel. (7) 525 2170, Fax (7) 525 2173  
**SI Mettler-Toledo, d.o.o., SI-1236 Trzin**, Tel. (016) 162 18 01, Fax (061) 162 17 89  
**TH Mettler-Toledo (Thailand), Bangkok 10310**, Tel. (662) 719 6480-7, Fax (662) 719 6479  
**TW Mettler-Toledo Pac Rim AG, Taipei**, Tel. (886) 2 2579 5955, Fax (886) 2 2579 5977  
**UK Mettler-Toledo Ltd., Leicester, LE4 1AW**, Tel. (0116) 235 0888, Fax (0116) 236 5500  
**US Mettler-Toledo, Inc., Columbus, Ohio 43240**, Tel. (614) 438 4511, Fax (614) 438 4900

**For all other countries: Mettler-Toledo GmbH**, PO Box VI-400, CH-8606 Greifensee, Tel. (01) 944 22 11, Fax (01) 944 31 70