

METTLER TOLEDO

Operator manual

METTLER TOLEDO
Viper Smart Count

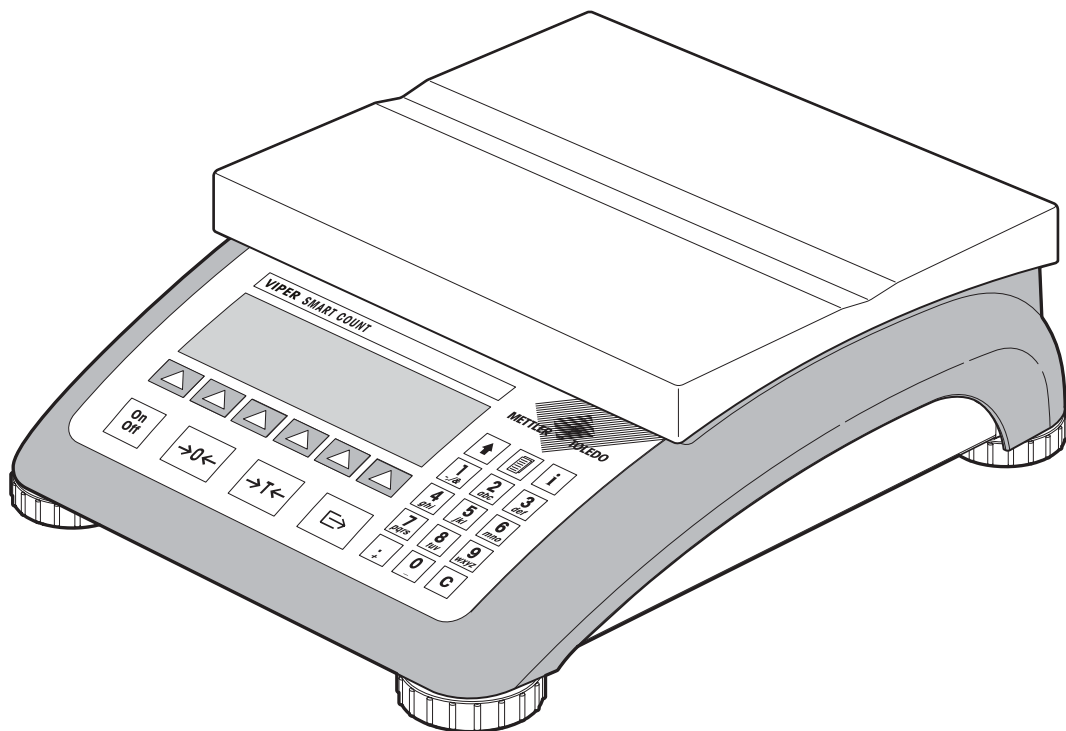

Overview

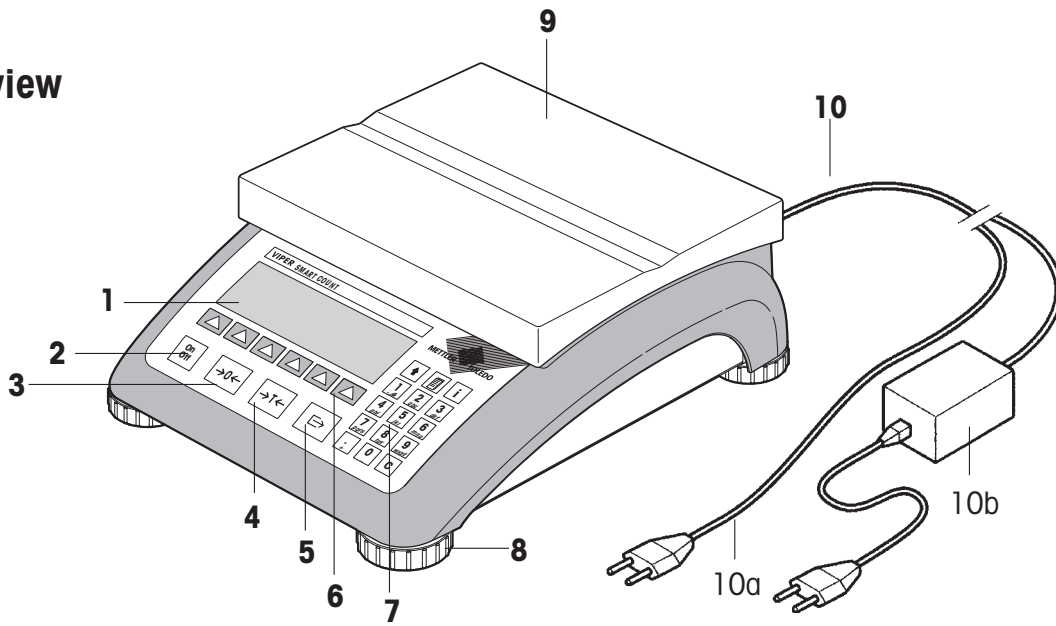

Rear of Scale

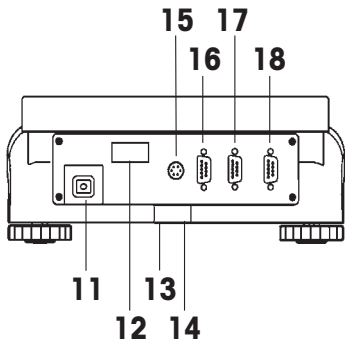

Keypad

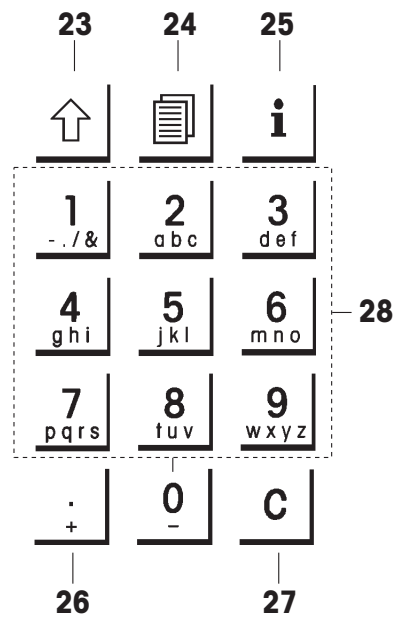

Scale specifications (example)

19	20	21	22
Max1: 3kg	Min1: 20g	e1: 1g	d1: 1g
Max2: 6kg	Min2: 40g	e2: 2g	d2: 2g

Display

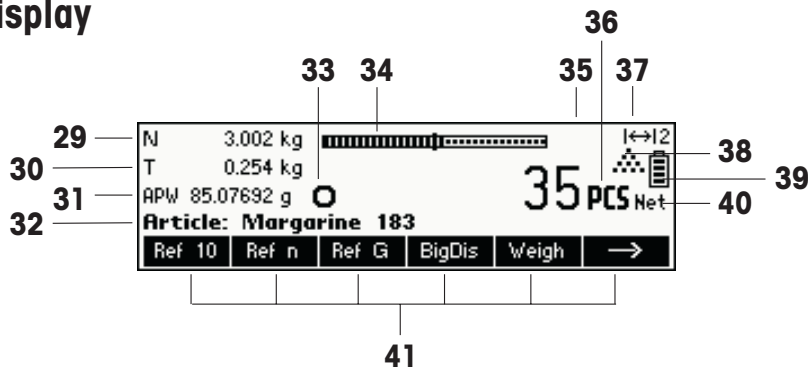

Overview

- 1** Display
- 2** On/Off key
- 3** Tare key
- 4** Zero key
- 5** Enter key
- 6** Command softkeys
- 7** Keypad
- 8** Adjustable feet
- 9** Weighing pan
- 10** Power supply:
 - 10a: power cord (scale w/o battery)
 - 10b: AC adapter (scale with battery)

Rear of scale

- 11** Power cord or jack for AC adapter
 - 12** Model plate
 - 13** Hole for anti-theft device
 - 14** Spirit level (only on certified scales and those with MonoBloc weighing cells)
- For Standard:
- 15** PS2 connector for keyboard and/or BCR (Barcode reader)
 - 16** COM3 (RS232C interface)
 - 17** COM2 (RS232C interface)
 - 18** COM1 (RS232C interface)
- For Optional Analogue Base:
- 15** PS/2 connector for keyboard and/or BCR (Barcode reader)
 - 16** Analog Base
 - 17** COM3 (RS232C interface)
 - 18** COM1/2 (RS232C interface), to access COM2 (Printer only) use included Y-cable

Scale specifications

- 19** Maximum loads (ranges 1/2)
- 20** Minimum loads (ranges 1/2)
- 21** Verification scale interval (certified scale) (ranges 1/2)
- 22** Max. resolution (ranges 1/2)

Keypad

- 23** Shift key
- 24** Database key
- 25** Info key
- 26** Special characters key
- 27** Clear key
- 28** Numeric/alphanumeric keys

Display

- 29** Info line 1
- 30** Info line 2
- 31** Info line 3
- 32** Info line 4
- 33** Stability detector
- 34** Weighing range bar graph
- 35** Active scale (in 2-scale systems)
- 36** Unit
- 37** Weighing range display
- 38** Piece counting symbol
- 39** Battery discharge status
- 40** Net weight indicator
- 41** Softkeys 1...6

4**Contents**

Page

1	Setting up the scale	8
1.1	Unpacking and checking contents	8
1.2	Safety and environment	8
1.3	Positioning and leveling the scale	9
1.4	Connecting to power supply	10
1.5	Battery operation	10
2	Basic functions	11
2.1	Switching on and off and zeroing	11
2.2	Setting date and time	11
2.3	Language settings	12
2.4	Simple weighing	13
2.5	Weighing with tare	14
	<i>2.5.1 Taring by placing the weighing container on the scale.....</i>	<i>14</i>
	<i>2.5.2 Entering the tare weight numerically (pre-tare).....</i>	<i>15</i>
	<i>2.5.3 Determining the gross and net weights</i>	<i>16</i>
2.6	Recording weighing results	16
3	Enhanced functions	17
3.1	General Info	17
3.2	Database	18
	<i>3.2.1 Database editing functions</i>	<i>18</i>
	<i>3.2.2 Defining an article</i>	<i>19</i>
	<i>3.2.3 Save As Article</i>	<i>21</i>
3.3	Backup/Restore	22
3.4	FlashLoader	22
4	Application	23
4.1	Counting pieces into a container	23
	<i>4.1.1 Determining the reference by placing pieces on the scale.....</i>	<i>23</i>
	<i>4.1.2 Entering the reference when the piece weight is known</i>	<i>24</i>
4.2	Counting out pieces out of a container	25
	<i>4.2.1 Determine reference by removing pieces</i>	<i>25</i>

Contents

	Page
4.3 Reference optimization	26
4.4 Minimum reference weight	26
4.5 Using the info key	27
4.6 Piece counting with 2-scale systems	28
4.7 Totalisation	29
4.8 Filling	30
4.9 Checkweighing (+/-)	31
4.10 Factor/Unit	31
4.11 Average weighing	33
5 Vision setup	34
5.1 Overview and operation	34
5.2 Calling up the menu and entering the password	35
5.3 Menu overview	36
5.3.1 Scale	36
5.3.2 Application	37
5.3.3 Terminal	39
5.3.4 Communications	40
5.3.5 Diagnostics	43
5.4 Scale settings (SCALE)	43
5.4.1 Adjust/calibrate (SCALE → Calibration)	44
5.4.2 Display resolution and weighing unit (SCALE → Display)	44
5.4.3 Tare settings (SCALE → Tare)	45
5.4.4 Automatic zero point correction (SCALE → Zero)	45
5.4.5 Automatic save of tare and zero values (SCALE → Restart)	46
5.4.6 Adaptation to environmental conditions and weighing mode (SCALE → Filter)	46
5.4.7 Resetting scale to factory default settings (SCALE → Reset)	47
5.5 Application settings (APPLICATION)	47
5.5.1 Settings for piece counting (APPLICATION → Counting)	47
5.5.2 Settings for database (APPLICATION → Database)	49
5.5.3 Settings for totalisation (APPLICATION → Totalisation)	50
5.5.4 Settings for filling/checkweighing (APPLICATION → Filling/Checkweighing)	50
5.5.5 Settings for softkey configuration (APPLICATION → Softkey Configuration)	51
5.5.6 Settings for Info/Help (APPLICATION → Info/Help)	52
5.5.7 Settings for reset (APPLICATION → Reset)	53

6**Contents**

	Page
5.6 Terminal settings for device (TERMINAL → Device)	53
5.6.1 Language settings (TERMINAL → Device → Language)	54
5.6.2 Sleep function (TERMINAL → Device → Sleep)	54
5.6.3 Turning off the backlight (TERMINAL → Device → Backlight)	55
5.6.4 Adjusting the contrast of the display (TERMINAL → Device → Contrast)	55
5.6.5 Invert (TERMINAL → Device → Invert)	55
5.6.6 Changing the size of weight display (TERMINAL → Device → Weight display)	56
5.6.7 Adjusting the date and time (TERMINAL → Device → Date Time)	56
5.6.8 Activating the beep (TERMINAL → Device → Beep)	56
5.7 Define supervisor password (TERMINAL → Access)	57
5.8 Reset terminal settings to factory settings (TERMINAL → Reset)	57
5.9 Communication settings (COMMUNICATIONS)	57
5.9.1 Mode (COMMUNICATIONS → Mode)	58
5.9.2 Parameters (COMMUNICATIONS → Parameters)	58
5.9.3 Define string (COMMUNICATIONS → Def. String – only if Mode is Printer or Auto Print)	59
5.9.4 Add LineFeed (COMMUNICATIONS → Add LineFeed)	60
5.9.5 Define I/O (COMMUNICATIONS → Def. I/O – only if Mode is Digital I/O)	60
5.9.6 Reset communications (COMMUNICATIONS → Comx → Reset Com)	61
5.9.7 Option Settings (COMMUNICATIONS → Option)	61
5.9.8 PS2 Settings (COMMUNICATIONS → PS2)	61
5.10 Diagnostic settings (DIAGNOSTICS)	62
5.10.1 Keyboard (DIAGNOSTICS → Keyboard Test)	63
5.10.2 Display (DIAGNOSTICS → Display Test)	63
5.10.3 Serial Number 1 (DIAGNOSTICS → SNR1)	64
5.10.4 Serial Number 2 (DIAGNOSTICS → SNR2)	64
5.10.5 List 1 (DIAGNOSTICS → List 1)	64
5.10.6 List 2 (DIAGNOSTICS → List 2)	64
5.10.7 List memory (DIAGNOSTICS → List Memory)	65
5.10.8 Reset All (DIAGNOSTICS → Reset All)	65
6 Other important information	66
6.1 Error messages	66
6.2 Sample reports	68
6.3 Cleaning instructions	68

Contents

	Page
7 Technical data, interfaces and accessories	69
7.1 General data and delivered items.....	69
7.2 Dimensions.....	70
7.3 Interface technical data.....	71
7.4 Accessories.....	71
7.5 Interface commands	72
7.5.1 <i>Preconditions</i>	72
7.5.2 <i>SICS Command set</i>	72
7.6 Declaration of conformity.....	76

1 *Setting up the scale*

Please read through these operating instructions carefully and adhere to them at all times. If you discover that materials are missing or that the wrong ones have been supplied, or if you have any other problems with your scale, please refer to the dealer and salesperson concerned, or if necessary to the METTLER TOLEDO representative responsible.

1.1 Unpacking and checking contents

Remove the scale and accessories from the packaging and check the delivered items:

- Terminal and weighing platform with installed weighing plan and level indicator (certified scales only)
- Open-end wrench for leveling the weighing platform
- Operating instructions (this document)
- Special accessories (if any) as per packing list

1.2 Safety and environment

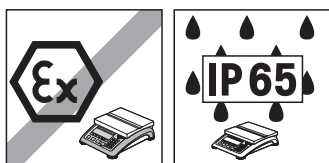

Do not use the scale in **hazardous areas** (unless it is clearly identified as being approved for these areas).

For service in **wet areas or dusty environments**, or if **wet cleaning** is necessary, scales with **IP 65 ingress protection** must be used. But even these scales must not be used in environments where there is a risk of corrosion. The scales must never be drenched or immersed in liquid.

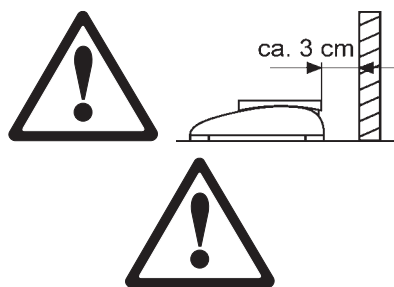

If the **power cord** is damaged, the scale must no longer be operated. Therefore check the cable regularly and ensure that a free space of about 3 cm is left at the rear of the scale, so that the cable is not kinked too severely.

Never tamper with the **retaining screws for the load plate support** underneath the weighing pan.

When the weighing pan is removed, **never insert a solid object underneath the load plate support**.

Never open the scale by removing the **screws in its base**.

Use only **approved accessories and peripherals**.

Handle the scale with **utmost care**; it is a precision instrument. Blows on the weighing pan must be avoided, and heavy overloads must not be placed on it.

Important instructions when using Viper scales in the **food sector**: those parts of the scale can come into contact with food products have smooth surfaces and are easy to clean. The materials used do not splinter and are free from contaminants. In food processing areas, it is recommended that a **protective cover** (accessory) is used. This must be cleaned regularly, just like the scale itself. Damaged or heavily contaminated protective covers must be replaced immediately.

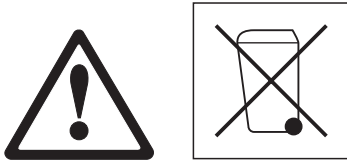

When the scale is finally **taken out of service**, observe the current environmental regulations. If the scale is equipped with a **battery**, this contains heavy metals and therefore must not be treated as normal refuse! Local regulations for disposing of environmentally hazardous substances must be complied with.

1.3 Positioning and leveling the scale

The correct location is a decisive factor in ensuring accurate weighing results.

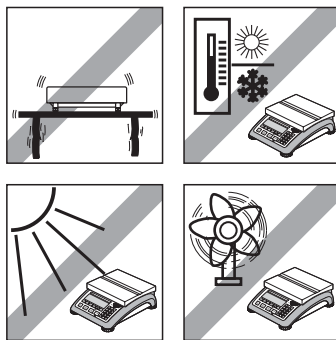

- Choose a stable and vibration-free location (particularly important for high-resolution scales using Mettler Toledo MonoBloc technology). Place the scale on a surface that is as horizontal as possible and strong enough to bear its weight when fully loaded.
- Check the ambient conditions.
- Avoid:
 - direct sunlight
 - strong drafts (e.g. from fans or air conditioning systems)
 - excessive temperature fluctuations.

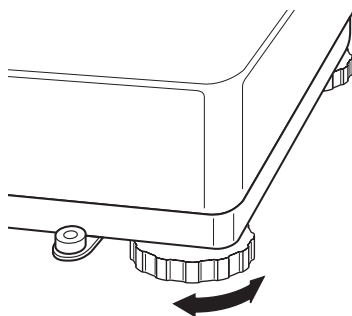

Turn the adjustable feet so that the scale is horizontal. If a spirit level is filled, the bubble must be located within the inner circle.

Note: The Viper Smart Count has a special filter that accelerates certain procedures (zeroing, taring, determining the reference weight for piece counting) in a non-tranquil environment. This inevitably means that there is a slight loss of accuracy with the results. For high-precision results, care must be taken to ensure as tranquil and stable an environment as possible, so that the filter is not activated.

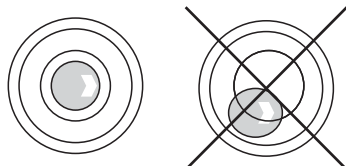

Major changes in geographical location:

Every scale is set by the manufacturer to suit the local gravitational conditions (geographical adjustment value) in the geographical zone to which the instrument is supplied. If a major change of geographical location takes place, this setting must be adjusted by a service technician or a new setting made. Certified scales must, in addition, be recalibrated in accordance with national certification regulations.

1.4 Connecting to power supply

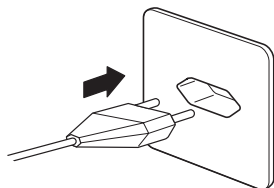

Before connecting the power supply plug or AC adapter (AccuPac version), verify that the voltage stated on the model plate is the same as the local power line voltage.

Connect the power cord plug or the AC adapter plug to the supply, then connect the AC adapter (AccuPac version) via the jack at the rear of the scale.



Powering up the scale initiates a display test in which all the segments and then the software version are briefly displayed. Once the decimal zero appears in the display, the scale is ready to operate.

For maximum possible precision, adjust/calibrate the scale after installing it (Chapter 5.4.1). **Note:** Certified scales must be adjusted by an authorized organization. Please consult your dealer.

1.5 Battery operation

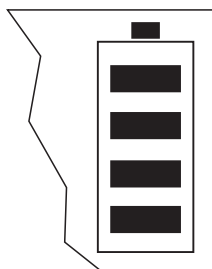

Scales with a built-in battery (AccuPac) can, under normal operation conditions, work independently of the AC power line for about 8 hours. Immediately the AC power supply is interrupted (by withdrawing the power cord plug or if there is a power failure), the scale switches automatically to battery operation. Once the AC power supply is restored, the scale reverts automatically to AC operation.

The battery symbol indicates the current discharge status of the battery (1 segment corresponding to about 25% capacity). If the symbol flashes, the battery must be recharged.

A discharged battery requires at least 8 hours until it is recharged. During the charging process, work with the scale can continue, but under these conditions, a longer charging time is needed.

The battery is protected against overcharging, and the scale can therefore remain permanently connected with the AC power line without any problems.

2 *Basic functions*

This Chapter describes how to switch the scale on and off, zero and tare it, weigh materials and record the results.

All displays are based on default settings "English".

2.1 Switching on and off and zeroing



Briefly pressing «**On/Off**» key switches the scale on or off.



The scale carries out a display test (Chapter 1.4). Once the weight display appears, the scale is ready to operate and automatically zeroed.

Note: The screen display shown here may not necessarily be the same as the display appearing on your scale. Please refer to Chapter 5 on how to navigate within the 'Vision Setup'-menu and how to define softkeys for each function.

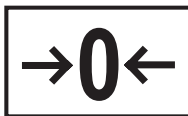

Note: If necessary, the scale can be zeroed at any time with the line «**→0←**» key.

2.2 Setting date and time

Time can be set in 24 hours or 12 hours format, and the date in European or US format.

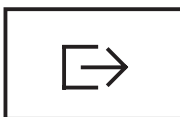

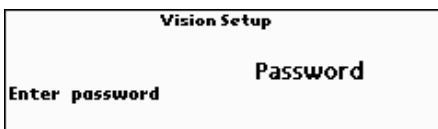

Press the «» key continuously for about 2 seconds.

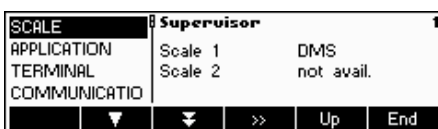

Briefly press the «» key again.



Select **TERMINAL** by pressing the «» key and press the «» key.



12

Device	Language	English	3-1
Access	Sleep	Off	
Reset	Backlight	On	
			Up End

Select **Device** and press the «**▶▶**» key.

Contrast	Date Format	EU	3-1-9
Invert	Date	22.07.2002	
Weight Display	Time	09:23:04	
Date Time			Up End

Select **Date Time** by pressing the «**▼**» key and press the «**▶▶**» key.

Date Format	Date	22.07.2002	3-1-9-2
Date			
Time			
		Edit	Up End

Select **Date** by pressing the «**▼**» key and press the «**Edit**» key.

Date Format	Date	22.07.2002	123
Date	Date :		
Time			
	Erase	←	→ OK Cancel

Use the numeric keypad to enter the date and confirm with the «**OK**» key. Incorrect inputs can be deleted with the «**Erase**» key. The «**←**» and «**→**» keys can be used to scroll the characters that are entered.

To set the correct time, do the same procedure but select **Time** instead of **Date**.

2.3 Language settings

Language can be set into US English, English, German, French, Spanish or Italian.



Press the «» key continuously for about 2 seconds.

Vision Setup	
Enter password	Password

Briefly press the «» key again.

SCALE	Supervisor	1
APPLICATION	Scale 1	DMS
TERMINAL	Scale 2	not avail.
COMMUNICATIO		
		Up End

...appears on the screen.

SCALE	Device	3
APPLICATION	Language	English
TERMINAL	Sleep	Off
COMMUNICATIO	Contrast	5
		Up End

Select **TERMINAL** by pressing the «**▼**» key and press the «**▶▶**» key.

Device	Language	English	3-1
Access	Sleep	Off	
Reset	Backlight	On	
			Up End

Select **Device** and press the «**▶▶**» key.



Select **Language** by pressing the «**▼**» key and then press the «**Edit**» key.



Choose the desired language and then press the «**OK**» key.

2.4 Simple weighing

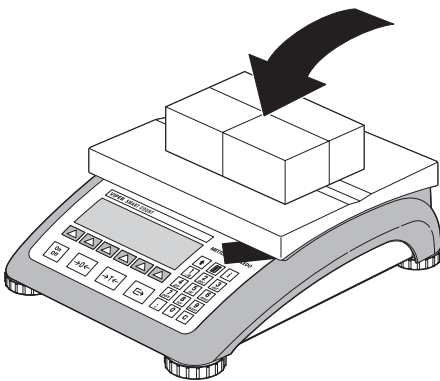

Place the object to be weighed on the scale.

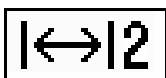
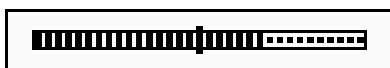
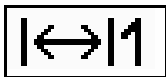
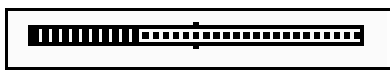

The bar graph at the top of the display shows how much of the weighing range is being used and how much is still available (as % of total scale capacity). The range symbol at the upper right corner of the display shows the first or second half of the range of the maximum load. **Note:** The number changes from 1 to 2 when set for 2 weighing ranges:

Example: 6 kg scale:

- 1. Range 0 – 3 kg Resolution 1 g
- 2. Range 0 – 6 kg Resolution 2 g

In order to switch from the 2nd range back to the 1st range, the load must first be removed from the scale or it must be zeroed.

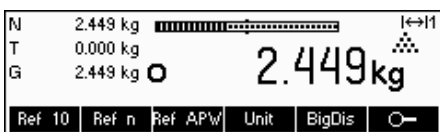

Wait until the stability detector (a small ring at the left edge of the display) disappears, then...

Note: Please refer to Chapter 5.5.5 'Vision Setup → APPLICATION → Softkey Configuration' on how to define softkeys. In this example, a new softkey was added, i.e. «**○**» softkey (high resolution).

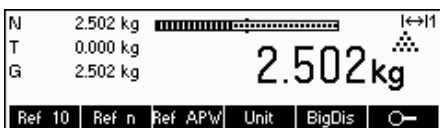

... read the indicated net weight and press the «**○**» key.

14

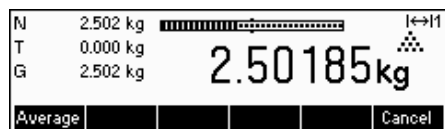

The «**↔**» key enables the weighing result to be displayed in control mode, i.e. with a higher resolution. Press «**Cancel**» key to go back to the normal weighing mode. Press «**Average**» key to perform average weighing. See also Chapter 4.11

Control mode is not available if the maximum resolution has already been selected in Vision setup (Chapter 5).

2.5 Weighing with tare

The tare can be specified by placing the weighing container on the scale or by entering the tare weight numerically. The two possibilities are described below. Moreover, the gross and net weights can be determined separately.

2.5.1 Taring by placing the weighing container on the scale

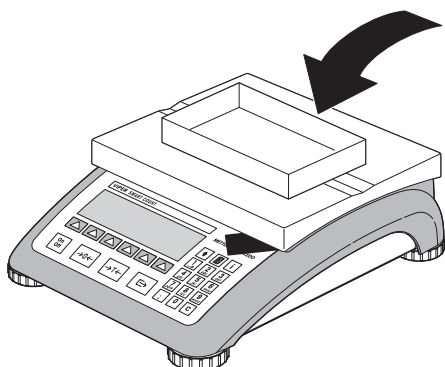

Place the **empty** weighing container or packaging on the scale.

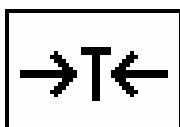

Press the «**→T←**» key briefly to tare the scale.

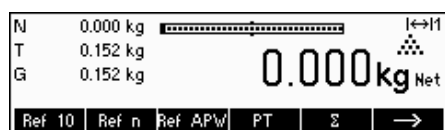

The zero display and the "Net" (net weight) symbol appear. Note: If the **automatic tare function** has been activated in Vision Setup (Chapter 5), there is no need to press the «**→T←**» key.

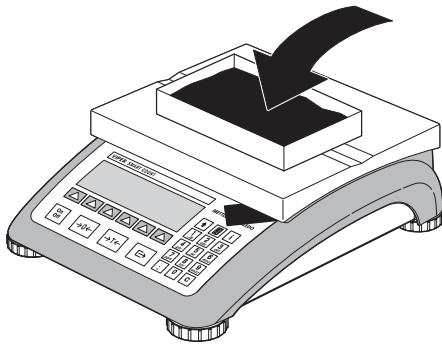

Place the material to be weighed in the container, then...



... read the result (net weight of the weighing sample).

Note: The tare weight is retained until either a new tare is determined, or the scale is set to zero or switched off. If the automatic taring function is active, the tare is automatically cleared when weighing is completed and the weighing pan emptied; the scale is then ready for the next taring and weighing.

2.5.2 Entering the tare weight numerically (pre-tare)

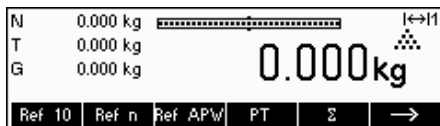

Press the «PT» key.



... appears on the screen.



Use the numeric keypad to enter the **known tare weight** in the current weighing unit and confirm with the «OK» key. Incorrect inputs can be deleted with the «Erase» key. The arrow keys can be used to scroll the characters that are entered.

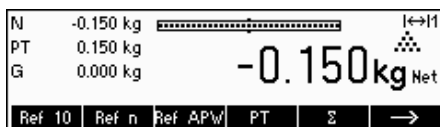

The tare values entered appear in the display with a negative sign and the symbol "Net" (net weight). As soon as the weighing container with the corresponding weighing is placed on the scale, the zero display appears.

2.5.3 Determining the gross and net weights

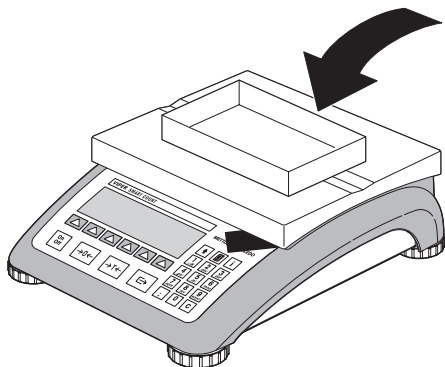

Place the **empty** weighing container or packaging on the scale and then press the «T<» key briefly, or press the «PT» softkey if a **known tare weight** has already been established.

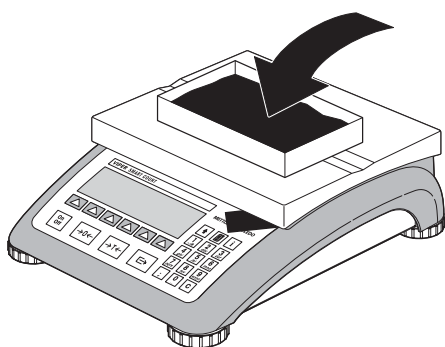

Place the material to be weighed in the container, then...

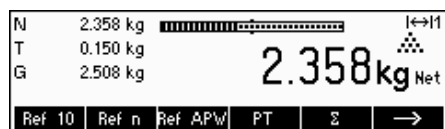

... read the indicated net weight. Scroll on the «>» key.



Press the «Gross» key. This function causes the gross weight to be displayed (the "G" symbol appears and replaces the "Net" symbol).



After a few seconds the scale automatically reverts to displaying the net weight.

2.6 Recording weighing results

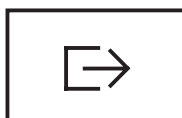

Press the «>» key to send the current weighing result to the peripheral device (printer, computer) via the interface. Factory default configures interface 1 for connection to a printer.

Please refer to Chapter 5 Vision setup for instructions on configuring the interface(s).

3 *Enhanced functions*

This Chapter describes the Smart Count features that simplify working with the application.

3.1 General Info

Smart Count provides several features which make working with the application easier.

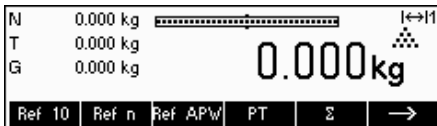

Short Input Mode

For some Smart Count functions, it is possible to use a short-cut method of user input.

As in the example for entering the pre-tare weight in Chapter 2.5.2, the normal procedure for initiating user input is to press the function softkey first before entering the data. However, it is also possible to key in the data first prior to selecting the function the data is intended for.



This example shows how to enter the pre-tare weight using short-input mode.



While in standby mode, use the numeric keypad to enter the **known tare weight** in the current weighing unit.

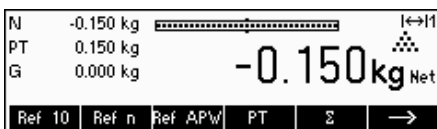

Then press the «PT» softkey or the «→T←» key to set this value as the pre-tare weight.

The result is the same as in Chapter 2.5.2.

Short-input mode works with the following function softkeys:

- «Ref X» The value keyed in replaces the value of X (Chapter 5.5.1) and perform a reference weight determination using the value as reference number of pieces (Chapter 4.1.1).
- «Ref n» The value keyed in will be used as the reference number of pieces for the reference weight determination.
- «Ref APW» The value keyed in will be used as the average piece weight.
- «PT» The value keyed in will be used as the pre-tare weight.

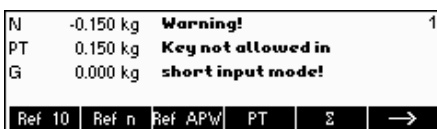

Smart Count recognizes if the function softkey pressed is not compatible with short-input mode and will display a warning indicating so.

3.2 Database

The following describes the operations for working with the article database.

N	0.000 kg	←→11
T	0.000 kg	
G	0.000 kg	
0.000 kg		
Ref 10	Ref n	Ref APW
PT	Σ	→

Briefly press the «» key.

Article	[No active article]
Batch	
Datab.	Batch
OK	Cancel

If any of the ID's in 'Vision Setup → APPLICATION → Database → ID1- ID3' are active (Please refer to Chapter 5.5.2 on how to use the ID's), you need to make a selection of which item to edit. In this example, ID1 "Softkey" and "Printout" were set to "Batch".

To enter the article database menu, press the «**Datab.**» softkey.

Note: If no ID is active, this screen will be skipped and you will be brought directly to the article database menu.

Database is empty.		
Create a new article?		
Yes	No	Cancel

The first time the article database is accessed, the database will be empty and Smart Count will prompt you to create a new article.

Maggi Dip	[Name1]	16-4/312
Maggi Dip 173	Numb	
Maggi Dip 272	ID1	
Maggi Dip 74	APW	0.000000 g
▲	▼	Search
Options	OK	Cancel

If articles have been previously defined, you will be presented with several options for working with the article database:

Press the «» key to select the previous article in the list.

Press the «» key to select the next article in the list.

Press the «**Search**» key to find an article in the list.

Press the «**Options**» key to perform other operations on the currently selected article (Chapter 3.2.1).

Press the «**OK**» key to make the currently selected article the active one for use with the various Smart Count applications and leave the article database menu.

Press the «**Cancel**» key to leave the article database menu. The article that was active before entering the article database menu will be retained except if that article was deleted. Other changes made to the database with the «**Options**» key will not be undone.

3.2.1 Database editing functions

The following describes various operations that could be performed on articles.

Maggi Dip	[Name1]	16-4/312
Maggi Dip 173	Numb	
Maggi Dip 272	ID1	
Maggi Dip 74	APW	0.000000 g
Delete	Copy	New
Define	Print	Close

With the desired article selected in the article list, press the «**Options**» key. You can then choose an operation to be done on the article.

Note: If a password was defined in 'Vision Setup → APPLICATION → Database → Article → Password' (Chapter 5.5.2) then you will be asked to enter the password before you can modify the selected article.

Maggi Dip	[Name]	16-4/312
Maggi Dip 173	Delete	
Maggi Dip 272	Maggi Dip?	
Maggi Dip 74		
		Yes No Cancel

Press «Delete» to remove the current article from the database. You will be asked to confirm deletion of an article.

Name	ABC	
Number		
Identification▶	Name	
APW▶		
		Erase ← → OK Cancel

Press «Copy» to create a duplicate of the selected article. All the parameters of the current article, except the name, will be copied into the newly created article.

Press «New» to create a blank article.

Name	Maggi Dip	1
Number	Name	
Identification▶	Maggi Dip	
APW▶		
		▼ Edit OK Cancel

Press «Define» to modify the selected article. Select the desired parameter by using the «▲», «▼», or «↔» softkeys, then press «Edit» to modify the selected parameter.

Number	Maggi Dip	4
Identification▶	APW	0.000000 g
APW▶		
Tare		
		▲ ▼ ↓ >> OK Cancel

A «>>» softkey in place of the «Edit» softkey indicates that there is a submenu for the selected item.

Press «Print» to print out the parameters of the selected article.

Maggi Dip	[Name]	16-4/312
Maggi Dip 173	Num	
Maggi Dip 272	ID1	
Maggi Dip 74	APW	0.000000 g
		▲ ▼ Search Options OK Cancel

Press «Close» to leave the article editing menu and return to the article selection menu.

3.2.2 Defining an article

The following describes the parameters of a Smart Count article.

Name	Maggi Dip	ABC
Number	Name	
Identification▶	Maggi Dip	
APW▶		
		Erase ← → OK Cancel

Name

The name of the article. If 'Vision Setup → APPLICATION → Database → Article → Search criterion' is set to "By name", this parameter is used for searching in the article database.

Name	Maggi Dip	123
Number	Number	
Identification▶	1028	
APW▶		
		Erase ← → OK Cancel

Number

The number of the article. If 'Vision Setup → APPLICATION → Database → Article → Search criterion' is set to "By number", this parameter is used for searching in the article database.

ID1	Maggi Dip	123
ID2	ID1	
	A01-555	
		Erase ← → OK Cancel

Identification / ID1 and ID2

Additional identification parameters for the article. These parameters could be used to provide additional information about the article in the report printouts.

20

Name	Maggi Dip	I↔11
Number	actual weight :	
Identification▶		44 g
APW▶		
Ref 10	Ref n	Ref APW
		OK Cancel

APW

Define the average piece weight of the article. It is possible to set the average piece weight for the article by performing a reference weight determination (Chapter 4.1.1) or by manually entering a known piece weight (Chapter 4.1.2).

Number	Maggi Dip	123
Identification▶		
APW▶	Tare	
Tare		10 g
	Erase	← → OK Cancel

Tare

Pre-defined tare weight for the article.

Identification▶	Maggi Dip	123
APW▶		
Tare	Sample Size	
Sample Size		10
	Erase	← → OK Cancel

Sample size

Define the reference number of pieces. This value will override the one set in 'Vision Setup → APPLICATION → Counting → Ref X' (Chapter 5.5.1) while the article is active.

APW▶	Maggi Dip	123
Tare		
Sample Size	PW Optimization	
PW Optimization		80 %
	Erase	← → OK Cancel

PW optimization

The correction factor for optimizing the piece weight. The previous value of the APW will be adjusted by this factor in relation to the new APW. **Note:** This works only if PW Tol+ and PW Tol- are set and the APW is within the tolerances.

Absolute	Maggi Dip	123
Relative		
Percent	PW Tol+	
		5 %
	Erase	← → OK Cancel

PW Tol+

The upper limit for a new average piece weight. If the new piece weight is above this value, a warning will be displayed prompting the operator whether or not he wants to accept the new piece weight. **Note:** APW must already be defined before setting the PW Tol+, otherwise the PW Tol+ entry will be cleared.

Absolute	Maggi Dip	123
Relative		
Percent	PW Tol-	
		5 %
	Erase	← → OK Cancel

PW Tol-

The lower limit for a new average piece weight. If the new piece weight is below this value, a warning will be displayed prompting the operator whether or not he wants to accept the new piece weight. **Note:** APW must already be defined before setting the PW Tol+, otherwise the PW Tol+ entry will be cleared.

Weight	Maggi Dip	1123
Pieces		
		100 g
	Erase	← → OK Cancel

Filling/checkweighing nominal

The nominal value used for the filling (Chapter 4.8) and checkweighing (Chapter 4.9) applications. It is possible to define the nominal value in pieces or as weight value. This parameter must be filled in first before defining Tol+ and Tol-.

Absolute	Maggi Dip	1123
Relative		
Percent	Tol+	
		3 %
	Erase	← → OK Cancel

Filling/checkweighing Tol+

The upper limit for filling (Chapter 4.8) and checkweighing (Chapter 4.9) applications. It is possible to define this parameter as an absolute value, relative to the Nominal, or as a percentage of Filling / Nominal.

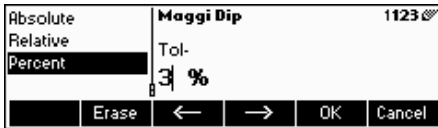

Filling/checkweighing Tol-

The lower limit for the filling (Chapter 4.8) and checkweighing (Chapter 4.9) applications. It is possible to define this parameter as an absolute value, relative to the nominal, or as a percentage of nominal.

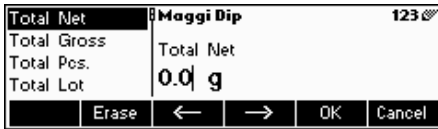

Accumulation total net

The total net weight for the Totalisation application (0)

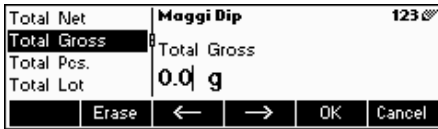

Accumulation total gross

The total gross weight for the Totalisation application (Chapter 4.7)

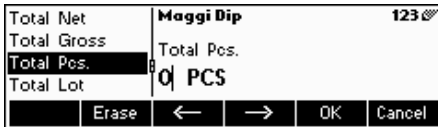

Accumulation total pcs.

The total number of pieces for the Totalisation application (Chapter 4.7)



Accumulation total lot

The total number of lots for the Totalisation application (Chapter 4.7)

3.2.3 Save As Article

In the course of working with Smart Count, you may wish to save the current state into an article. The Save As Article function makes this possible.

Define a softkey for "Save As Article" in the softkey configuration (See Chapter 5.5.5).



In this example, a reference weight determination has already been performed (Chapters 4.1.1 and 4.1.2).

Press the «**→**» softkey once to scroll to the next set of softkeys.



Press the «**SaveAs**» softkey...



...Smart Count asks for the Name you wish to use for this article. From this point on, the procedure is the same as defining a normal article (Chapter 3.2.2).



Note, however, that the parameter APW is already defined and its value is set to the APW that was active before «**SaveAs**» was pressed.

Aside from the APW, the article parameters that will also be saved are Tare, Sample Size, the Filling/Checkweighing parameters, and the Totalisation parameters.

3.3 Backup/Restore

To make working with the article database even easier, a backup/restore program is included as a standard equipment of Viper Smart Count. This program eases data entry as articles can be defined on a standard PC which are then later restored to the scale. This program also provides a means to backup the data stored on the scale for archive or security reasons.

- Install the Backup-Restore program. (Requires MS Windows 95 or higher)
- Ensure that Viper Smart Count balance is connected to the PC via a serial interface cable. It is possible to use any of the 3 COM ports of the balance but it is necessary to set the correct mode and parameters for the COM port. Set the respective COM settings as follows: Mode – Dialog / Baud – 38400 / Parity – 8-none / Handshake – XonXoff.
- Start up the Backup-Restore program by double-clicking the icon.
- The Backup-Restore program attempts to reserve the COM2 port of the PC. If it is not successful, e.g. COM2 is not installed or is used by another program, an appropriate message is shown. Should this be the case, select the appropriate port in the "Interface Configuration" under the Options menu.
- To check if the PC and scale are successfully connected, select "Help / About". An animation will indicate whether the Backup-Restore program was able to successfully communicate with the scale.
- If you have determined that the Backup-Restore program can successfully communicate with the scale, you may start the desired operation. Select either "Backup" or "Restore" from the "Transfer menu."

3.4 FlashLoader

The Viper Smart Count software is stored in flash memory and the FlashLoader program enables you to upgrade the software of your balance when updates are available.

To be able to update your software using the FlashLoader, you will need the following:

- PC with Microsoft Windows ® operating system (version 95, 98, NT 4.0, 2000, or XP)
- Computer-to-balance connection cable (RS232 cable, 9-pin sub-D plug m/f, order number 11101051)
- FlashLoader program

The FlashLoader program will guide you through the updating process.

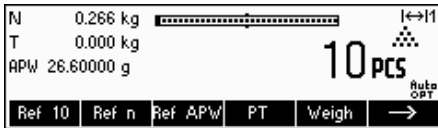

A **reference weight** has been established.

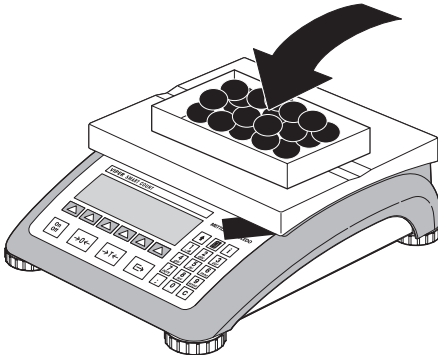

If a **different number of pieces** has been placed on the scale, press the «**Ref n**» key and choose from among the choices of **5, 20, 30, 40 or 50 pieces**. If the number of pieces is different, choose the «**Var**» key and enter the desired number of pieces.



Once a reference has been determined, you can use the «**Weigh**» key to switch back to the weight display at any time.



Press «**Count**» key to switch back again to counting mode.



You can use the «» key to transmit the piece counting result via the interface to a peripheral device (printer, computer) (for sample report see Chapter 6.2).

4.1.2 Entering the reference when the piece weight is known

Define a softkey for "Ref APW" in the softkey configuration (See Chapter 5.5.5). After the Ref APW softkey has been defined, do the following steps:

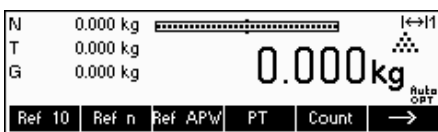

In standby mode, press the «**Ref APW**» key.

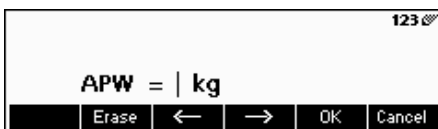

Enter piece weight, example: 0.02931 kg

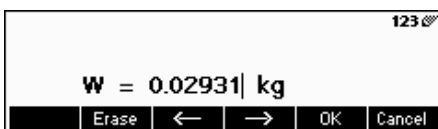

Press the «**OK**» key.

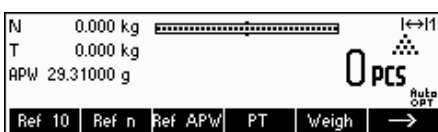

The balance has established a known reference weight and is now ready for piece counting.

4.2 Counting out pieces out of a container

Counting out pieces from a weighing container differs in a few essentials from counting them in (Chapter 4.1).

4.2.1 Determine reference by removing pieces

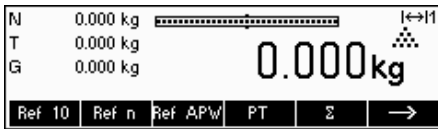

...initially appears on the screen.

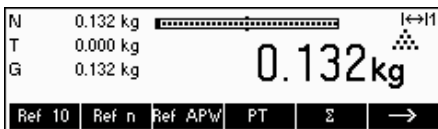

Place the full weighing container on the pan and tare the scale with the «→T←» key.

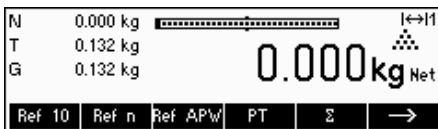
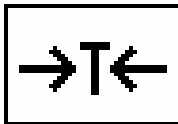

... appears on the screen again.

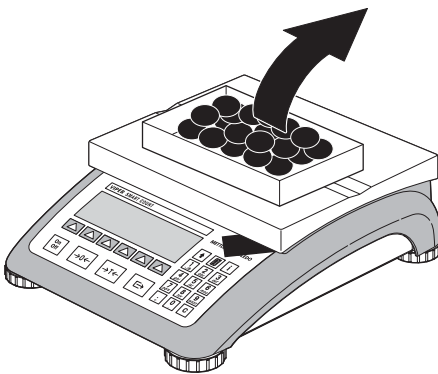

Remove the reference number of pieces from the weighing container.

Remove further pieces until the desired number has been reached.

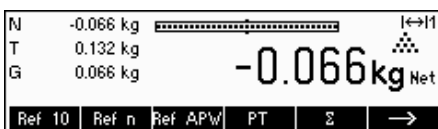

... a negative weight value appears on the screen.



Press the «**Ref 10**» or «**Ref n**» keys to determine the reference, as described in the previous chapter.

The balance is now ready for piece counting.

4.3 Reference optimization

Reference optimization serves to enhance the accuracy of the average piece weight by re-calculating it using a greater number of reference pieces. Reference optimization can be performed either manually or automatically.



Manual Reference Optimization

Define a softkey for Reference Optimization in the softkey configuration (See Chapter 5.5.5). The Reference Optimization softkey is displayed as «**RefOpt**» and it will only be active while in piece counting mode. If the scale is in weighing mode, this softkey will not appear even if it is part of the softkey configuration.

To perform a reference optimization at any time, press the «**RefOpt**» softkey. The average piece weight will be re-calculated using the current weight and the current number of pieces on the scale. At each optimization, the message "**PW Opt**" appears briefly and the new total number of pieces is then displayed.



Automatic Reference Optimization

No action is required during operation for automatic reference optimization and it functions both in "Counting in" (Chapter 4.1) and "Counting out" (Chapter 4.2). The "**Auto OPT**" symbol (located near the lower right corner of the screen) appears in the display indicates that automatic reference optimization is switched on.

Each time you place additional parts on the scale, it optimizes automatically. You do not have to press a key to perform optimization. At each optimization, the message "**PW Opt**" appears briefly and the new total number of pieces is then displayed.

Note: Automatic optimization only functions if the number of additional pieces placed on the scale is not greater than the number already on the weighing pan.

4.4 Minimum reference weight

To ensure that a more accurate average piece weight is attained during reference weight determination, it is possible to set a desired minimum percentage accuracy as determined by the reference weight placed on the scale. To enable minimum reference weight checking, set 'Vision Setup → APPLICATION → Counting → Min. Ref. WT' (See Chapter 5.5.1) to the desired percentage accuracy.

To be able to view the percentage accuracy for a reference weight determination, set 'Vision Setup → APPLICATION → Counting → Accuracy Disp.' (See Chapter 5.5.1) to 'On'.

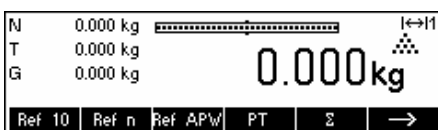

In this example, the minimum reference weight was set to 99.5% and accuracy display is active.

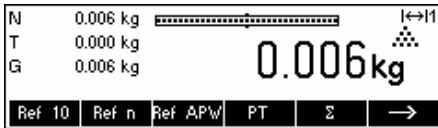

10 samples were placed on the scale and «Ref 10» was pressed.

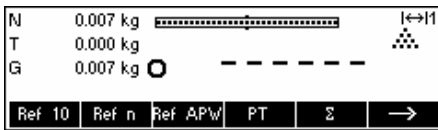

Smart Count calculates the average piece weight as in Chapter 4.1.1 but it has determined that the percentage accuracy for the reference weight is below the value set as Minimum Reference Weight.



It will calculate the number of pieces that you have to place on the pan to reach the desired percentage accuracy.

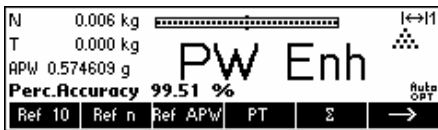

After placing the specified number of pieces on the scale, the average piece weight will be optimized (Chapter 4.3) and, since accuracy display is active, the percentage accuracy will be displayed for approximately 4 seconds.

Note that in this example, the percentage accuracy is at 99.54% which is above the desired minimum reference weight of 99.5%.



Smart Count is now ready to perform piece counting using the optimized average piece weight.



It is possible to override the minimum reference weight checking by pressing the «C» key when you are prompted to add pieces on the scale. This will enable you to use the calculated piece weight, but note that a "*" appears on the display to indicate that the reference weight is below the desired percentage accuracy.

Adding mode works both with "Counting in" (Chapter 4.1) and with "Counting out" (Chapter 4.2).

4.5 Using the info key

Use the «i» key to call up additional information as defined in the **Info/Help** menu under **Application** (Chapter 5.5.6).



In this example, Info lines 1 to 4 were configured to show the gross weight, date, time, and percentage accuracy respectively.



Pressing the «i» key will toggle between a screen that shows the default content of the Info lines and another window that shows the additional information configured such as the Gross Weight, Date, Time and Percentage Accuracy.

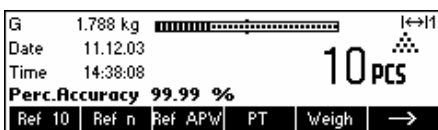

For a list of the additional information that can be displayed on the Info lines, please refer to Chapter 5.5.6.

4.6 Piece counting with 2-scale systems

You can hook up your Viper scale to a second scale, e.g. a floor scale for counting a large number of pieces that would exceed the capacity of Viper.

In the Vision Menu select the Smart Count operating mode for connecting a second scale. See Chapter 5: Vision setup under "Communications" → "Com1/Com2/Com3" → "Mode".

The interface of the second scale must be set as follows:

- **For Viper and Spider scales:**
"Mode": "Dialog" (9600 bd, 8b no parity, Xon/Xoff)
- **For PB-S scales:**
"Mode": "Host" (9600 bd, 8b no parity, Xon/Xoff)
- **For other METTLER TOLEDO products:**
MT-SICS-compatible interface (9600 bd, 8b no parity, Xon/Xoff)

There are three modes that can be assigned to the second scale:



Reference The second scale is to be used for reference weight determination only. The APW will be calculated using the weight placed on the second scale regardless of the active scale. This is used if the second scale has a finer resolution than the Smart Count scale to achieve a more precise piece weight.



Bulk The second scale is to be used as bulk weight only. The APW will be calculated using the weight placed on the first scale (Smart Count scale), regardless of the active scale, then the weight on the second scale will be used for counting. This is used if the sample to be weighed is heavier than the maximum load of the Smart Count scale.

Auxiliary The second scale can be used as either reference or bulk scale and the active scale will not be automatically switched after the reference weight determination.



When an interface is set to one of the three modes above, the scale switch key will be added to the softkeys. You can toggle between the two scales with the «» key.

While in Reference or Bulk modes, you can override the source used for reference weight determination by keeping the «» key pressed for 1 second. Info line 4 will indicate which scale will be used for reference weight determination.

The scale symbol on the top right in the display indicates the active scale: " 1" = viper scale, " 2" = second scale.

When the second scale is active, you can zero and tare it with the Viper «0T» keys, respectively.

4.7 Totalisation

If the scale is in piece counting mode, you can do several piece counts and then determine the total number of pieces weighed and their total weight. If the scale is in weighing mode, several weighings can also be accumulated to determine their total.

To print reports of the totalisation transactions, a printer should be connected to one of the COM Interfaces and the mode should be set to "Printer".

Define a softkey for Totalisation in the softkey configuration (See Chapter 5.5.5). After a Totalisation softkey has been defined, do the following steps:

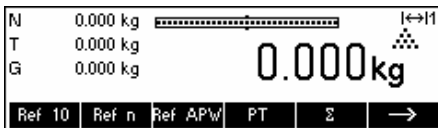

If a weighing container is used, it must be tared.

Determine the reference (see Chapter 4.1)



Press the «**→**» key to go to the next menu.



Press the «**Σ**» key to start the totalisation function.



Press the «**+**» key to add the current number of pieces to the total.



The quantity of the first lot has been saved in the memory. If Lot printing is active (Chapter 5.5.3) the lot number, net weight and number of pieces will be printed out automatically.

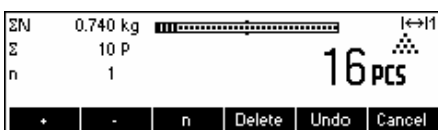

Place the desired quantity of the second lot and press the «**+**» key to add again.

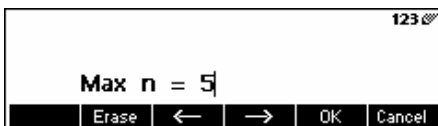

Press the «**n**» key to limit the number of lots to accumulate.



If **Max n** is defined, it will only be possible to accumulate as many lots as the value set. Once the number of lots accumulated reaches the value of **Max n**, a warning will be displayed indicating that maximum items have been reached.

Press the «**Delete**» key to clear all the lots from the memory. A summary report with the total number of lots, total weight, and total number of pieces will be printed out.

Press the «**Undo**» key to discard the last lot added.

To close the Totalisation application at any time, press the «**Cancel**» key. This will return the scale to standby mode but the lots accumulated will be retained in memory.

To close the Totalisation application and clear all the lots from memory, press the «**C**» key. This will also generate a summary report.

Note: If an article was active when the Totalisation application was started, the Totalisation parameters (Chapter 3.2.2) of the article will be updated by the transactions done with the application. That means the total net or gross weight, the total pieces, and the number of lots will be added to the values already stored in the database for the active article

4.8 Filling

The filling application simplifies weighing of small parts (e.g. liquid or powder) until a target amount or weight is reached. It provides the user a visual indication of the amount currently on the scale in relation to the target amount. If activated in the Vision Setup, the scale will also beep if the amount is already within the tolerance limits defined.

Define a softkey for Filling in the softkey configuration (See Chapter 5.5.5). After a Filling softkey has been defined, do the following steps:

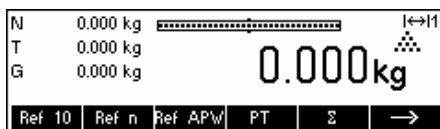

In standby mode, press the «**→**» key to scroll to the next menu.

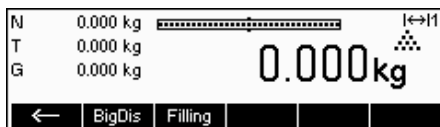

Press the «**Filling**» key.

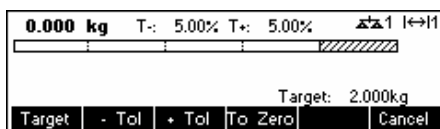

In this example, **Target** (target weight), **+ Tol** (positive tolerance) and **- Tol** (negative tolerance) have been defined. The first bar graph that appears is the coarse range indicator. The fine range, as shown by the gray area in the bar graph, depends on the tolerance limits set. As the tolerance limits are increased or decreased, the size of the fine range will also be adjusted accordingly.

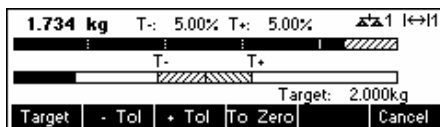

Place sample to be weighed on the scale.

As soon as the weighed amount reaches the start of the fine range, a second bar graph appears that shows the fine range.

For very small tolerance limits, there will be a third-stage indicator that will appear to show the fine range.

Please refer to the Notes in Chapter 4.9 for additional information.

4.9 Checkweighing (+/-)

The checkweighing application simplifies verification of sample weights or amounts. It provides the user with visual indicators to show whether or not weight of the sample is within tolerance limits of a specified target weight or amount.

Define a softkey for Checkweighing in the softkey configuration (See Chapter 5.5.5). After a checkweighing (+/-) softkey has been defined, do the following steps:

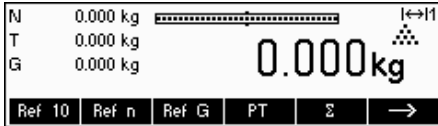

In standby mode, press the «» key to scroll to the next menu.

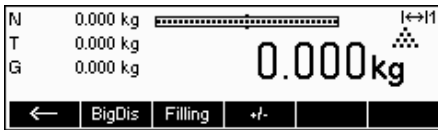

Press the «» key.

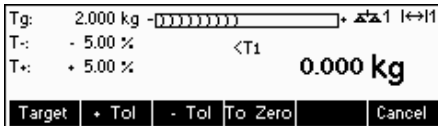

In this example, **Target** (target weight), **+ Tol** (positive tolerance) and **- Tol** (negative tolerance) have been defined.



Place sample to be weighed on the scale.

The indicators help the user easily verify the weight if the sample is within the targets defined.

Notes:

The Filling and Checkweighing applications use the filling parameters stored in the article database (Chapter 3.2.2) if they are defined and if they are in the same mode (weighing or piece counting). For example, if Filling/Checkweighing Nominal is defined as weight and the scale is currently in weighing mode, it will not be possible to define Target, Tol+, and Tol- while the Filling or Checkweighing applications are active. The values for these parameters will be taken from those defined in the current article. If however, Filling/Nominal is defined as weight and the scale is in counting mode, the Filling parameters of the article will not be used and the Target, Tol+ and Tol- parameters of the Filling or Checkweighing applications will have to be defined inside the application.

Clearing the currently selected article by pressing the «**C**» key while in standby mode will not clear the values defined for Target, Tol+, and Tol-. To clear these parameters, the «**C**» has to be pressed while inside the Filling or Checkweighing applications.

4.10 Factor/Unit

The Factor/Unit weighing function allows weighing using a unit that can be defined freely.

Define a softkey for Factor/Unit in the softkey configuration (See Chapter 5.5.5). After a Factor/Unit softkey has been defined, do the following steps:



In standby mode, press the «» key to scroll to the next menu.

32

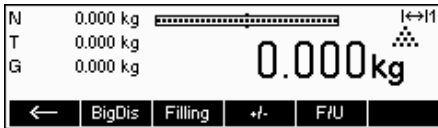

Press the «F/U» key.

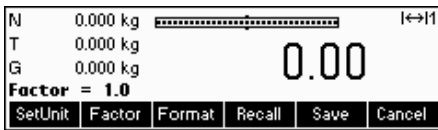

From the main Factor/Unit screen you can define the text for the custom unit, set the factor to use for weighing, recall previous definitions, or save the current definition.



Define the text for the custom unit.

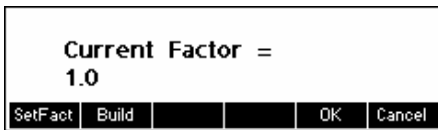

The factor can either be entered manually or can be calculated from the weight of samples placed on the balance.

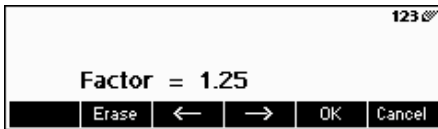

To define the factor manually, press the «SetFact» softkey.

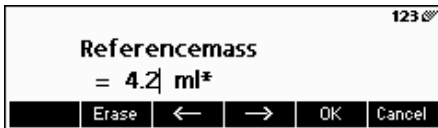

To use the automatically calculated factor, place the sample on the scale, press the «Build» softkey and enter the reference mass.

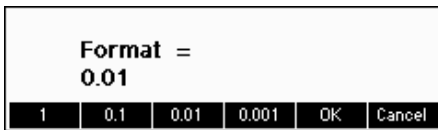

To change the resolution of the display, press the «Format» softkey and select the desired format.



You can save the factor and unit you have just defined by pressing the «Save» softkey. While in this screen, you can delete other Factor/Unit definitions you have already saved or save your current definition.

To save the current definition, press «Save» and enter the name you wish to give this definition.

You can save up to 25 Factor/Unit definitions.



To recall previous Factor/Unit definitions, press the «Recall» softkey and select the name of the Factor/Unit definition you wish to use.

4.11 Average weighing

The Average weighing function allows weighing of unstable goods (e.g. animals). It takes around 10 seconds to calculate the average weight of the load. This function also works in piece counting mode.

Define a softkey for Average weighing in the softkey configuration (See Chapter 5.5.5). After an Average weighing softkey has been defined, do the following steps:



In standby mode, press the «» key to scroll to the next menu.

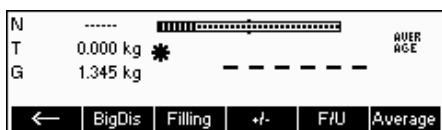

Place the load on the scale and press the «**Average**» key. Smart Count will then take weight readings for 10 seconds and average these weight values.

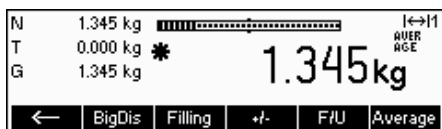

After 10 seconds, Smart Count will display the average weight of the load. Note that the 'AVERAGE' indicator on the upper right side of the display is visible while in Average weighing mode.

While in this mode, the weight displayed is frozen and small variations in the actual weight due to the unstable load will not be reflected on the display.

If the load changes more than 10% then the weight display will be released and Average weighing is no longer active.

5 *Vision setup*

Vision Setup can be used to change the settings of the scale and to activate functions, thereby allowing the scale to be adapted to individual weighing needs.

Important: To avoid incorrect operation of the scale in normal use, Vision Setup can be protected with a password. The scale differentiates between a user and a supervisor. When the scale leaves the factory, the entire menu can be accessed by both user and supervisor. **We therefore recommend you to define your own supervisor password as soon as you set up the scale (Chapter 5.7).** This limits access by the user to a smaller number of menu items (calibration, and settings for energy-saving mode and backlighting).

5.1 Overview and operation

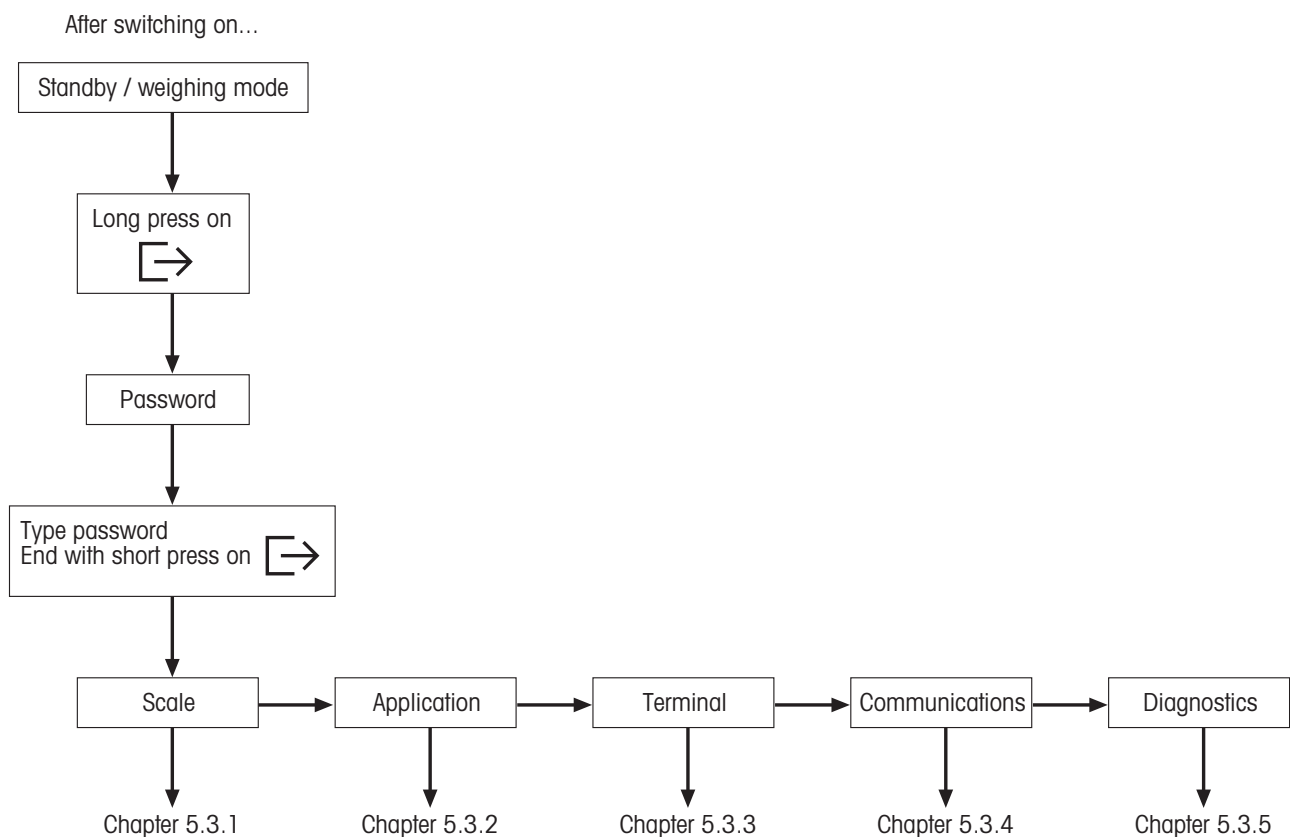

Navigating through the Vision Menu is done through the six softkeys found at the bottom of the display. The softkeys change depending on the currently selected menu item to allow the user to perform the appropriate action for the selected item.



This key selects the previous item listed on the current menu.



This key selects the next item listed on the current menu.



This key selects the first item on the next "page" of the menu. If all the items for the current menu are visible (i.e. there are four or less items for the current menu), this key is not visible.

>>

This key enters the submenu of the currently selected item. If the currently selected item does not have a submenu, this key is not visible.

Up

This key leaves the current submenu and goes one level up. If the Vision Menu is already at the top level, pressing this key is similar to pressing «**End**» (see below).

Edit

This key allows the user to edit the value or setting of the currently selected item. If the currently selected item contains a submenu, this key is not visible.

Yes

Some menu items perform specific actions rather than editing. Pressing this key directs the Vision Menu to perform the action specified by the currently selected menu item.

End

This key can be pressed at any time to leave the Vision Menu. The Vision Menu will then prompt the user to save or discard the changes the user has made. The user may also press «**Cancel**» at this time to go back to the Vision Menu.

i

This key allows the user to get an overview of the current location within the Vision Menu structure.

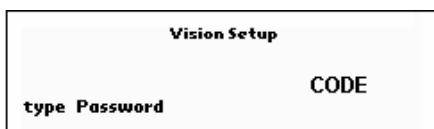

5.2 Calling up the menu and entering the password



Press the «» key and hold it down until the prompt to enter the password appears.



User: No password required, just press the «» key.

Supervisor: Enter password (sequence of keystrokes, Chapter 5.7) **immediately** and confirm with the «» key. Otherwise after a few seconds the scale returns to weighing mode. If an incorrect password is entered, the menu cannot be called up. **Note:** When the scale leaves the factory, no supervisor password is defined, so when the password is requested, just press the «» key.

5.3 Menu overview

5.3.1 Scale

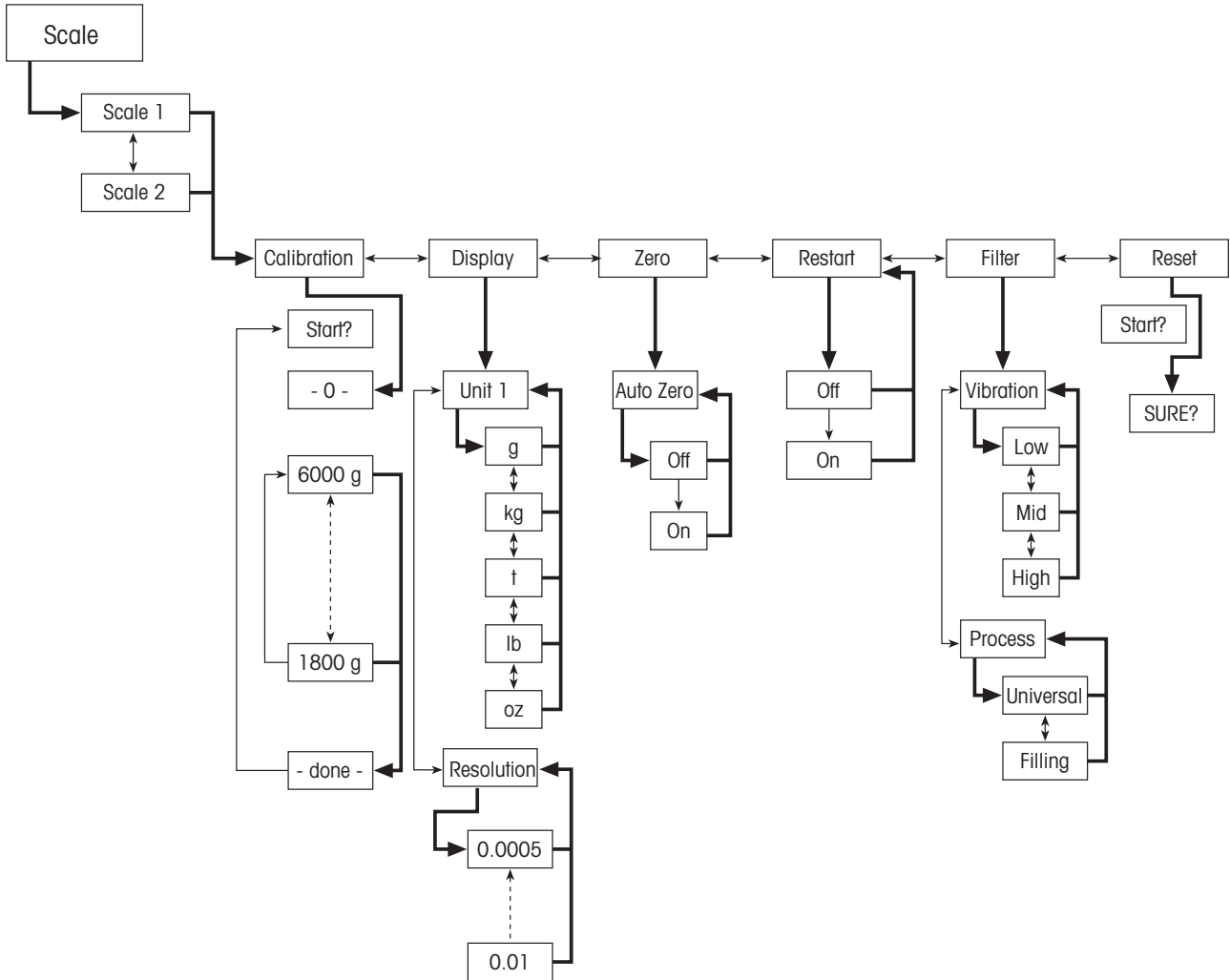

5.3.2 Application

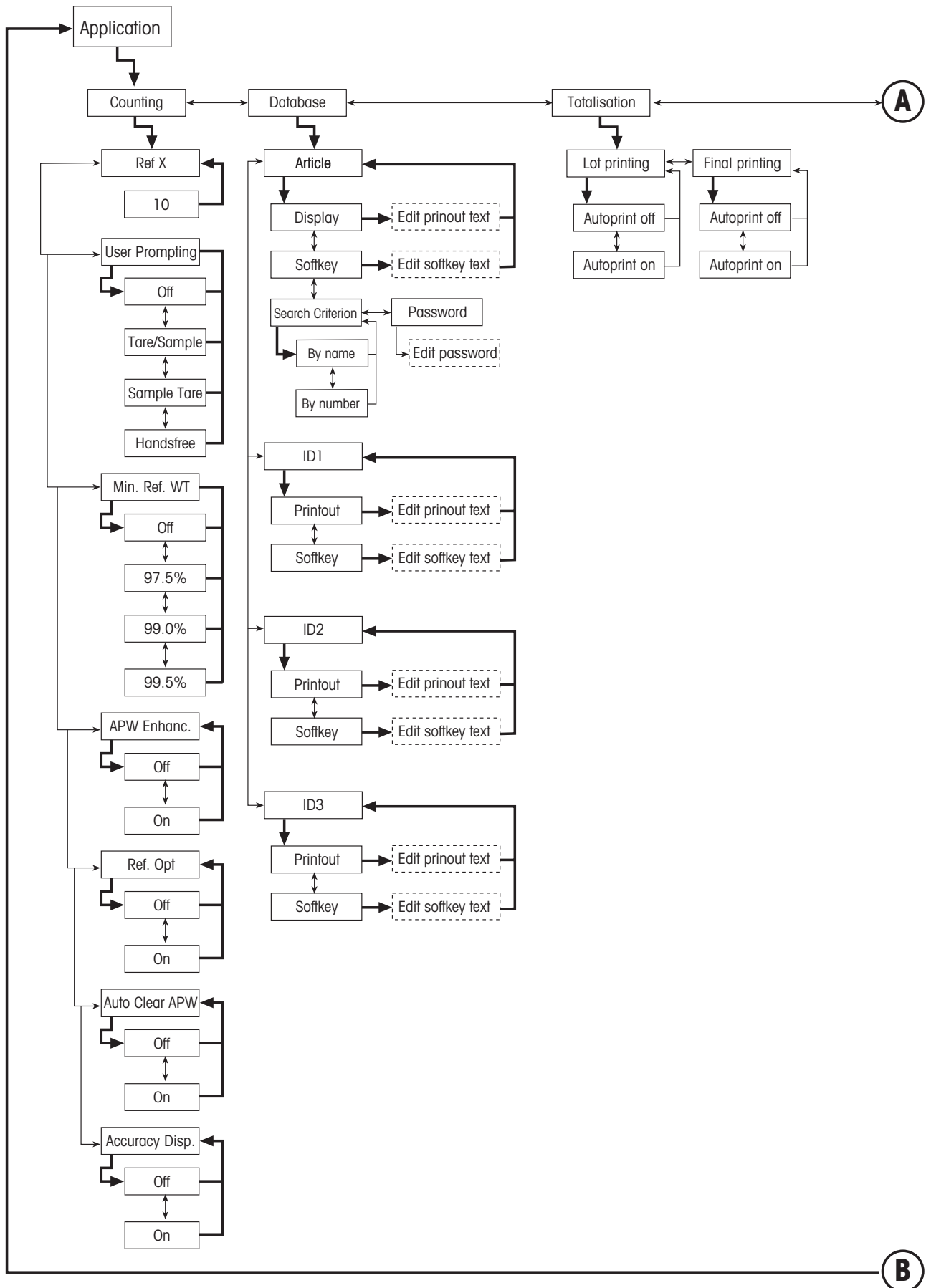

38

Applications continued....

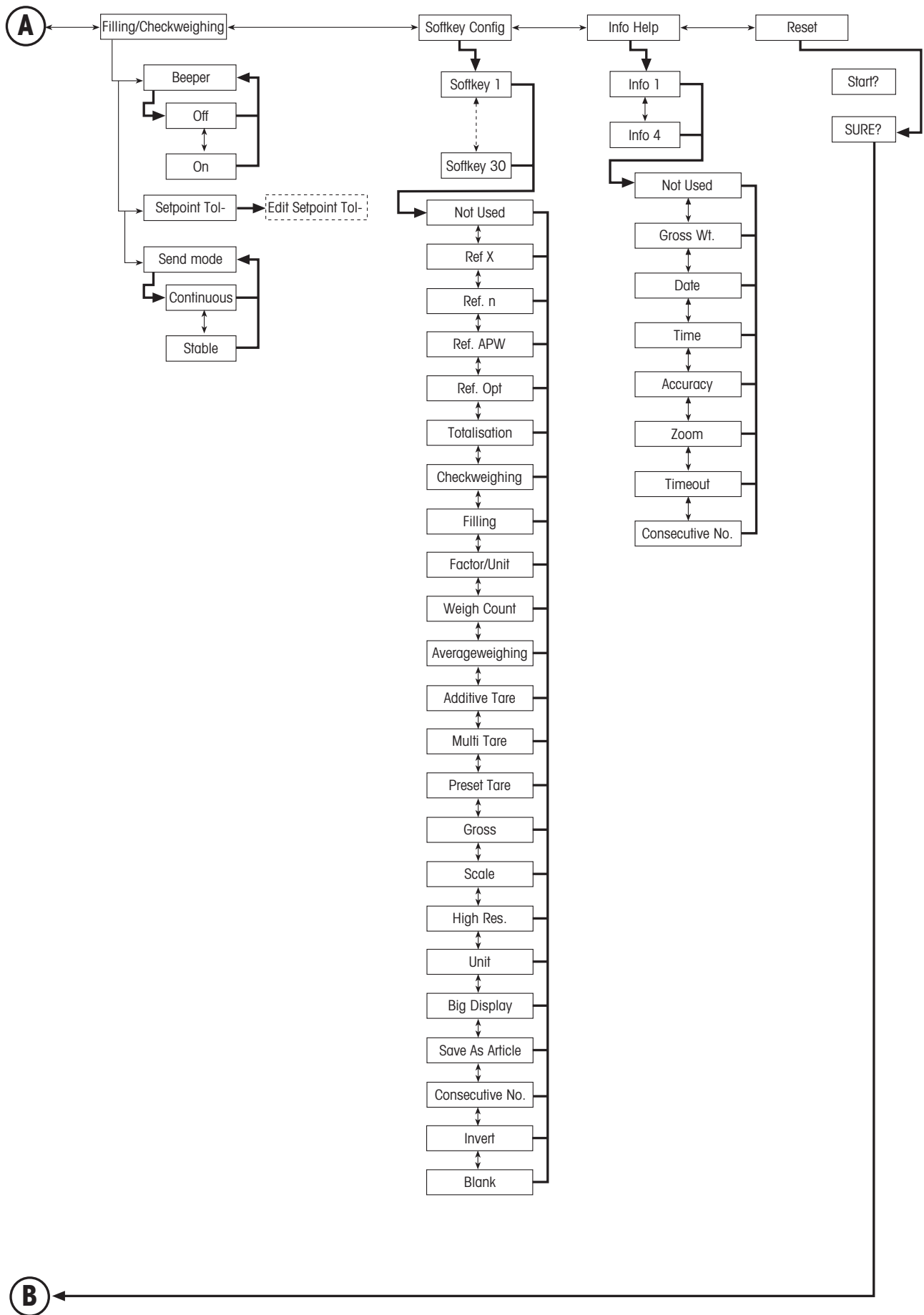

5.3.3 Terminal

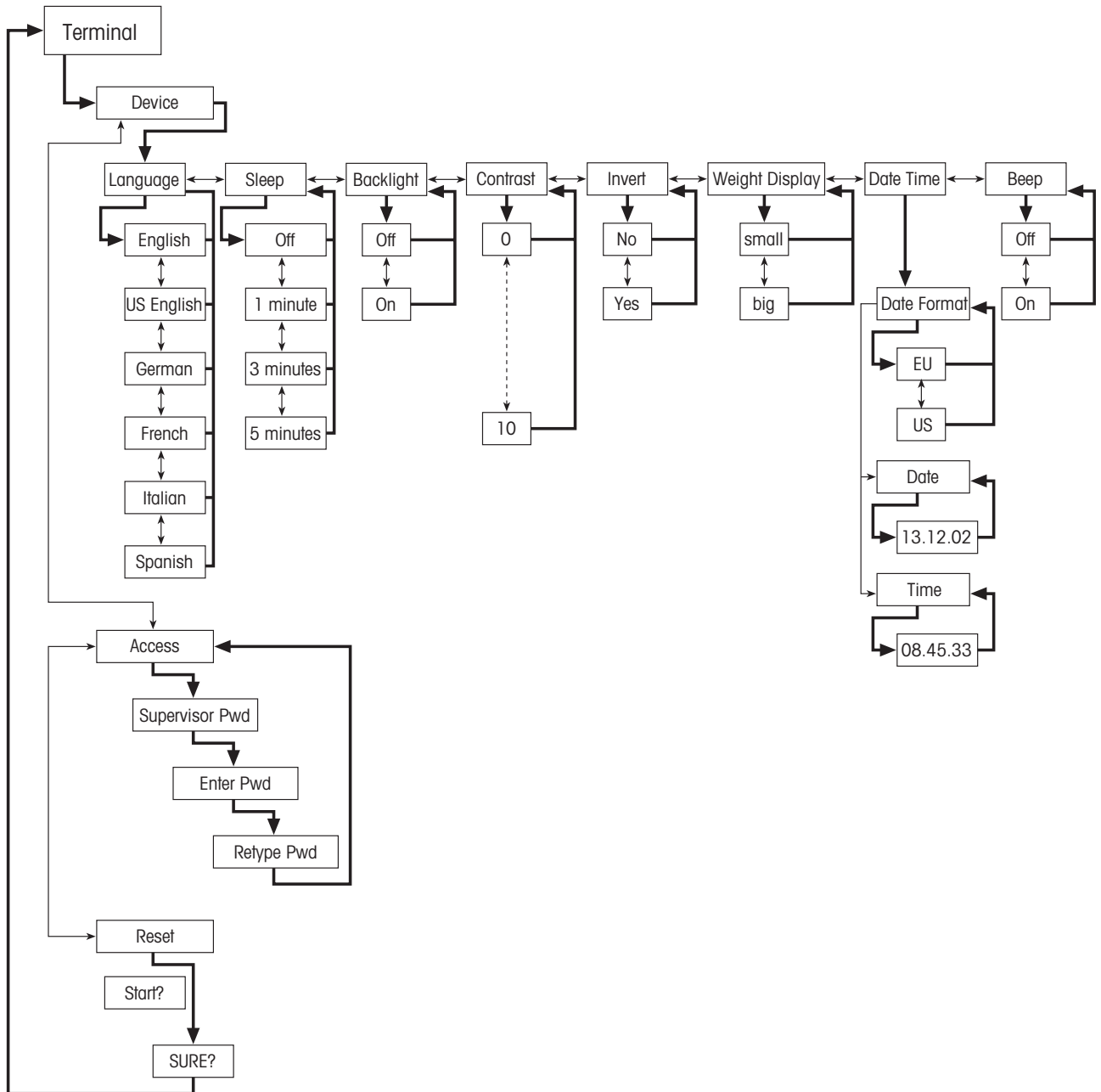

5.3.4 Communications

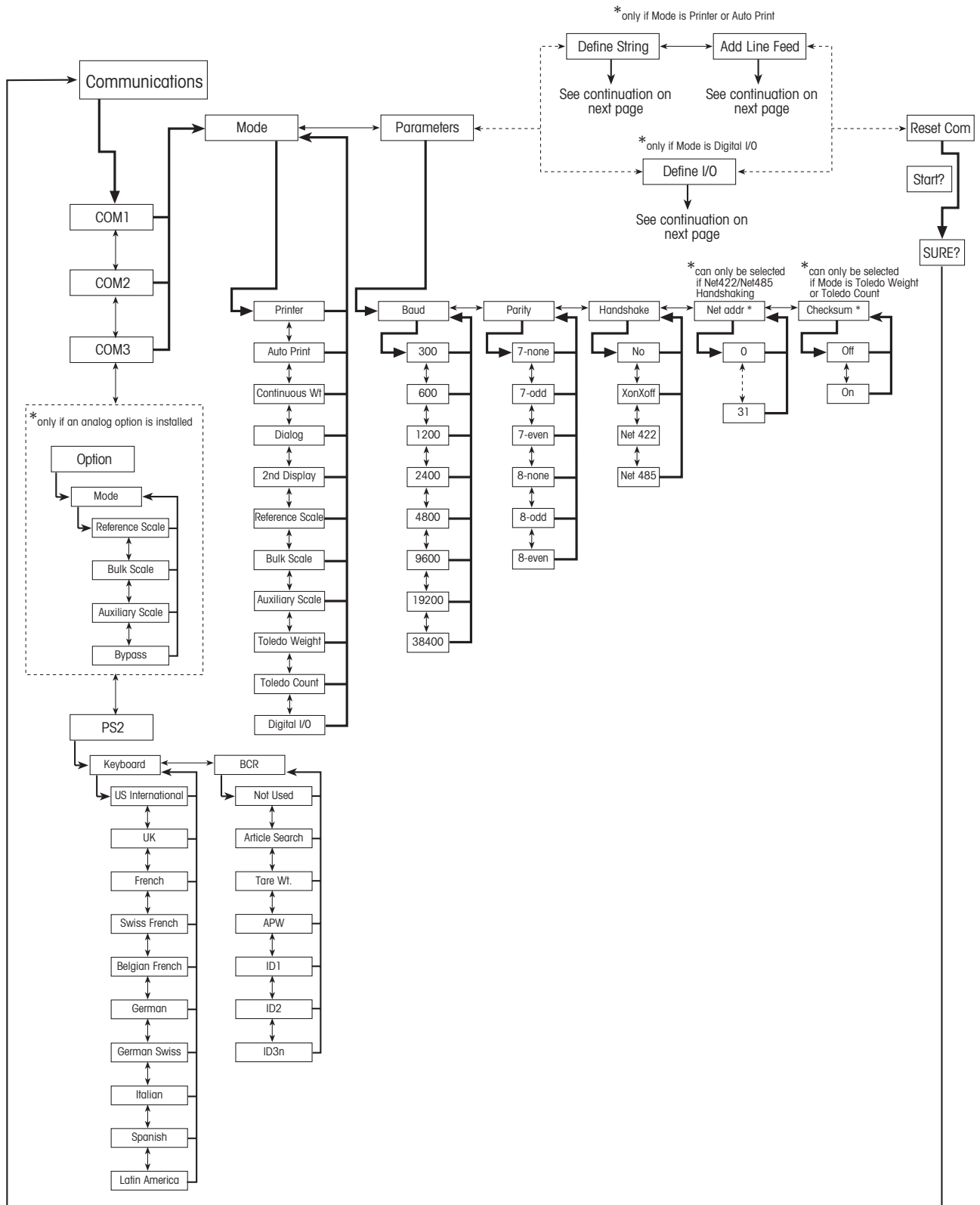

Communications continued... (only if Mode is Printer or Auto Print)

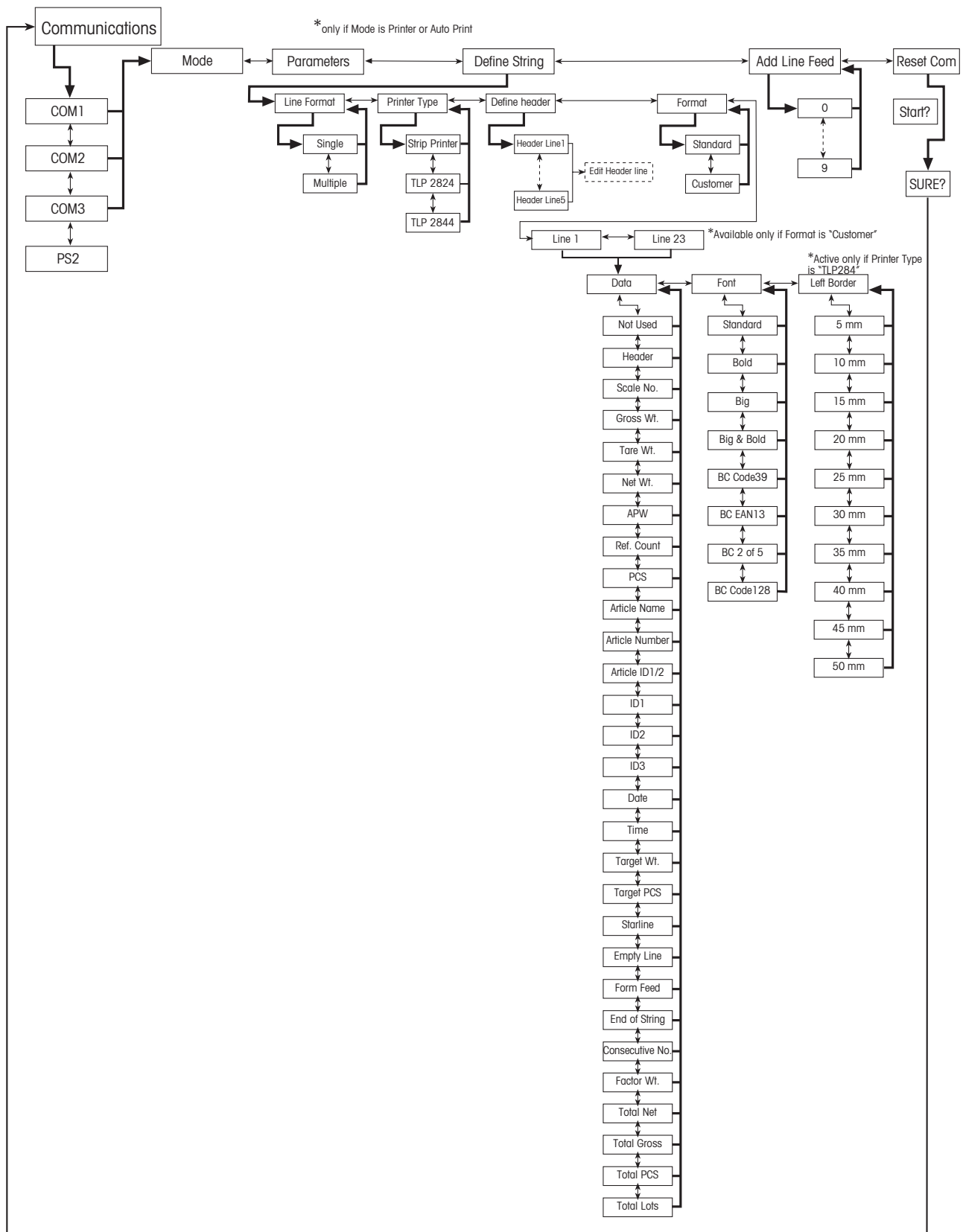

42

Communications continued... (only if Mode is Digital I/O)

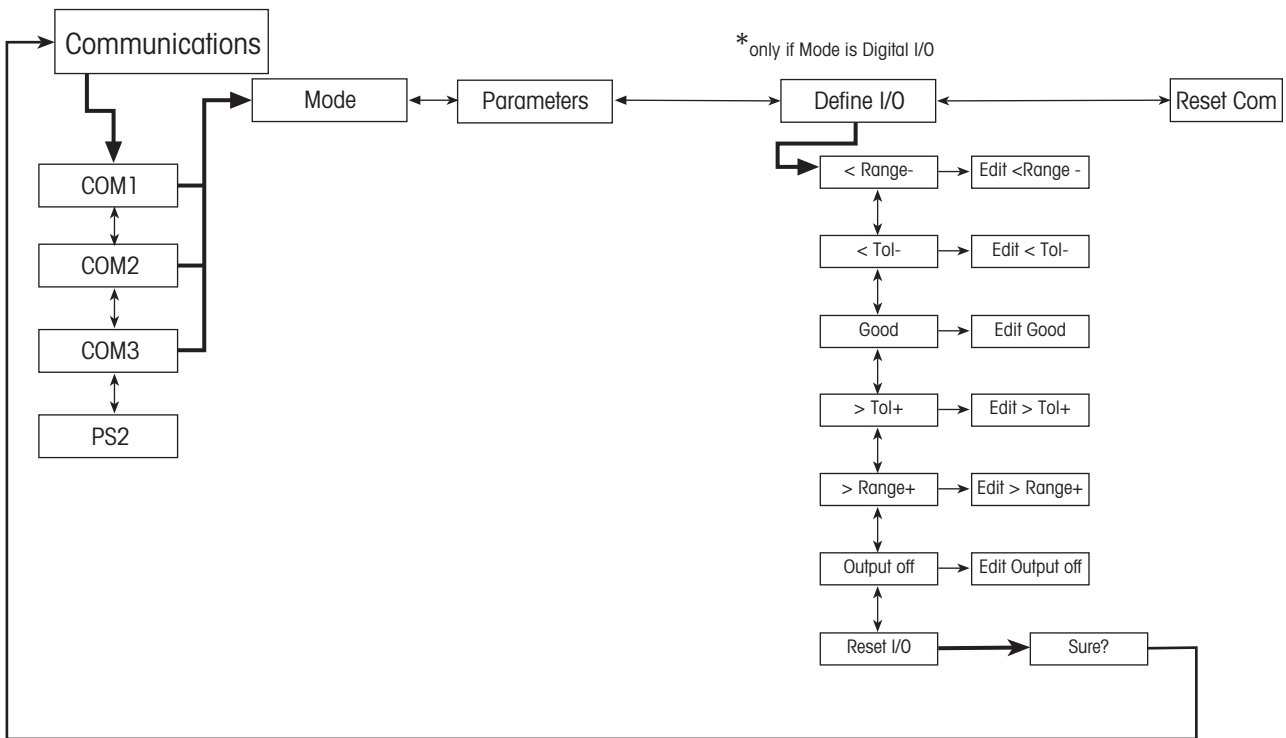

5.3.5 Diagnostics

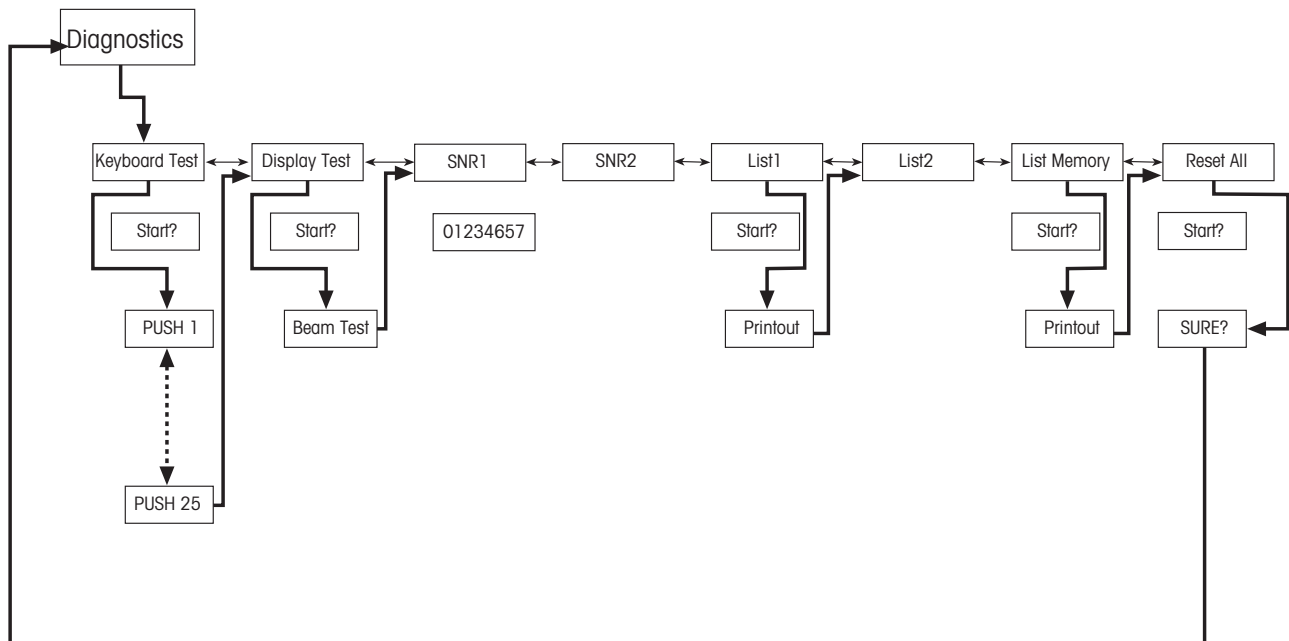

5.4 Scale settings (SCALE)

This function block allows the user to change general scale functionality.

Please refer to Chapter 5.2. on how to reach the menu position 'Vision Setup → SCALE' and how to navigate within the 'Vision Setup'-menu.

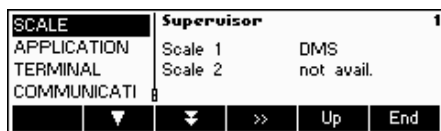

The screen shows the most important scale settings as a preview.

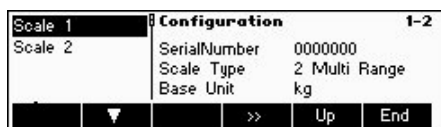

The screen shows a preview of the most important settings of the active item, e.g. those of scale 1 if 'Scale 1' is active (i.e. highlighted).

Enter the SCALE menu (◀▶▶▶), select the appropriate scale (Scale 1 or 2; note that this submenu appears only if a second scale is installed with the analog option) and choose one of the functions listed below.

Available functions and settings:

- Adjust/calibrate the scale → Chapter 5.4.1
- Display accuracy and weighing unit → Chapter 5.4.2
- Tare settings → Chapter 5.4.3
- Automatic zero point correction → Chapter 5.4.4
- Automatic storage of tare and zero values → Chapter 5.4.5
- Adaptation to environmental conditions and weighing mode → Chapter 5.4.6
- Reset 'SCALE' settings to factory settings → Chapter 5.4.7

5.4.1 Adjust/calibrate (SCALE → Calibration)

This function enables the scale to be adjusted/calibrated (weighing pan must be empty). **Not available on certified scales!**

Please refer to Chapter 5.2 on how to reach the menu position 'Vision Setup → SCALE → Calibration' and how to navigate within the 'Vision Setup'-menu.



Press «**Yes**» and follow the instructions given on the screen.

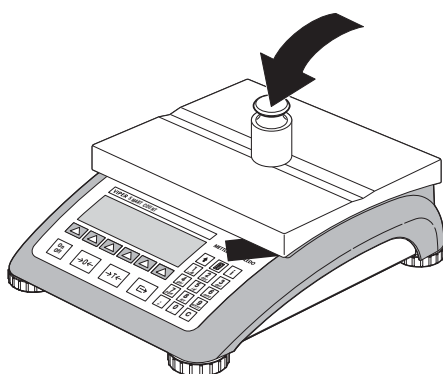

After choosing the calibration weight, place the weight on the weighing pan and then press the «**OK**» key.

It is recommended to use the maximum calibration weight from the list. If it is not possible to use the maximum weight, at least do not use less than one-third of the maximum load to ensure reliable weighing values.



Calibration is done. Continue with other functions or press «**End**» and confirm with the «**Yes**» key to save the changes.

Note: Abort calibration at any given time by pressing the «**Cancel**» key.

5.4.2 Display resolution and weighing unit (SCALE → Display)

This function allows the user to change the weighing unit, to add a second unit (to switch between Unit 1 and Unit 2, a softkey 'Unit' has to be configured in 'Vision Setup → APPLICATION → Softkey Config. ') and to set the resolution of the weight (always Unit 1).

Please refer to Chapter 5.2 on how to reach the menu position 'Vision Setup → SCALE → Display' and how to navigate within the 'Vision Setup'-menu.

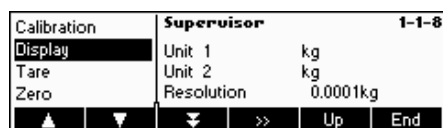

Press «**»**» and select e.g. "Unit 1", then «**Edit**» to change the unit.



In order to change the settings of the resolution of the balance, select "Resolution" (this function is not available on all models).



Use the «**▼**» key and the «**▲**» key to select the desired resolution and press the «**OK**» key. For multi range scales, the 'd1' resolution may be available twice (depending on the scale model), as single range and as multi range (with symbol in top right corner).

Note: For Multi Range scales, changing the resolution will disable the range icon. To re-enable it, select a resolution which is indicated as Multi Range.

5.4.3 Tare settings (SCALE → Tare)

This function allows the user to configure all the available tare function of the balance.

Please refer to Chapter 5.2 on how to reach the menu position 'Vision Setup → SCALE → Tare' and how to navigate within the 'Vision Setup'-menu.



Switch the available functions **Auto Tare**, **Chain Tare**, **AutoClr Tare** or **Pushb. Tare** either On or Off.

Automatic tare automatically tares the scale once a load is placed on the weighing pan. If this is active, the icon AT flashes on the lower right side of the display.

Chain tare allows several tare actions without clearing the tare memory. If this is not active, the tare memory has to be cleared by pressing the «**C**» key. The tare memory has to be cleared before a new tare can be performed.

Automatic clear tare automatically clears the tare memory once the load is removed from the weighing pan.

Push button tare enables/disables the use of the «**→T←**» key to perform manual taring.

5.4.4 Automatic zero point correction (SCALE → Zero)

With Auto Zero, small deviations in the weight (in the range of 50% of 1d) are automatically zeroed. **Always active for certified scales!**

Please refer to Chapter 5.2 on how to reach the menu position 'Vision Setup → SCALE → Zero' and how to navigate within the 'Vision Setup'-menu.



Press «**Edit**» to switch the Auto Zero function on or off.

5.4.5 Automatic save of tare and zero values (SCALE → Restart)

This function allows the user to set the scale so that it is able to automatically save the tare and zero values after switching off or when a power outage occurs. **Not available on certified scales. Automatic save switched off is the factory setting.**

Block can only be accessed by a supervisor.

Please refer to Chapter 5.2 on how to reach the menu position 'Vision Setup → SCALE → Restart' and how to navigate within the 'Vision Setup'-menu.

Display	Supervisor		1-1-11		
Tare	Restart	Off			
Zero					
Restart					
▲	▼	▼	Edit	Up	End

Press «**Edit**» to switch the automatic save switch function on or off.

5.4.6 Adaptation to environmental conditions and weighing mode (SCALE → Filter)

Vibration function allows the user to set the scale so that it is able to adapt itself to the existing environmental conditions.

Process function allows the user to set the weighing mode of the scale (weighing process adapter).

Block can only be accessed by a supervisor.

Please refer to Chapter 5.2 on how to reach the menu position 'Vision Setup → SCALE → Filter' and how to navigate within the 'Vision Setup'-menu.

Tare	Supervisor		1-1-12		
Zero	Vibration	Mid			
Restart	Process	Universal			
Filter					
▲	▼	▼	>>	Up	End

Press «**>>**» to go to the vibration and process settings menu.

Vibration	Supervisor		1-1-12-1		
Process	Vibration	Mid			
	▼	Edit	Up	End	

Vibration:

Low: For very stable and stable environment. Scale operates very quickly but is more sensitive to external influences.

Mild: For normal environment conditions. Scale operates at medium speed (**factory setting**).

High: For unstable environment. Scale operates more slowly but is less sensitive to external influences.

Process:

Universal: Setting for all weighing types and normal weighing goods (**factory setting**)

Filling: Setting for dispensing liquids or powdery substances.

5.4.7 Resetting scale to factory default settings (SCALE → Reset)

This function resets the 'SCALE' block to its original factory settings. Can only be accessed by a supervisor.

Please refer to Chapter 5.2 on how to reach the menu position 'Vision Setup → SCALE → Reset' and how to navigate within the 'Vision Setup'-menu.



Press «**Yes**» to reset the scale settings. 'SURE?' will appear, press «**Yes**» to confirm. The scale settings are now reset to its original factory settings.

5.5 Application settings (APPLICATION)

This function block allows the user to change the count application specific settings of the scale. Can only be accessed by a supervisor.

Please refer to Chapter 5.2 on how to reach the menu position 'Vision Setup → APPLICATION' and how to navigate within the 'Vision Setup'-menu.

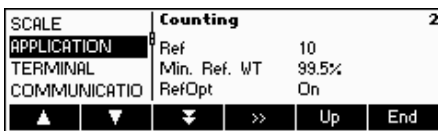

Enter the APPLICATION menu («>>>») and choose one of the functions listed below.

Available functions and settings:

The screen shows the most important application settings as a preview.



- Settings for piece counting → Chapter 5.5.1
- Database → Chapter 5.5.2
- Settings for totalisation → Chapter 5.5.3
- Settings for filling/checkweighing → Chapter 5.5.4
- Settings for softkey configuration → Chapter 5.5.5
- Info/Help → Chapter 5.5.6
- Reset 'APPLICATION' settings to factory settings → Chapter 5.5.7

The screen shows a preview of the most important settings of the active item, e.g. those of counting if 'Counting' is active (i.e. highlighted).

5.5.1 Settings for piece counting (APPLICATION → Counting)

The Ref X parameter determines the amount of pieces used to get the average piece weight.

Please refer to Chapter 5.2 on how to reach the menu position 'Vision Setup → APPLICATION → Counting' and how to navigate within the 'Vision Setup'-menu.



Press «**Edit**» to change the settings into the desired number of pieces. After the Ref X has been changed, the number of references in the main menu changes accordingly (e.g. 'Ref 10').

Ref X		2-1-2
User Prompting	User Prompting Off	
Min. Ref. WT		
RefOpt		
▲	▼	▼ Edit Up End

Off		1/4
Tare/Sample		
Sample/Tare		
Handsfree		
▼		OK Cancel

User Prompting

This setting allows the user to be in either dependent or independent mode of operation. The dependent mode provides a prompting display for a pre-selected sequence of operation. The display will prompt the operator through a complete counting sequence. The prompt will be shown in the display instead of article data. The independent mode allows the operator to choose the data to be entered and in which order. It is the default mode of the scale.

User prompting can be either one of the following modes:

- Tare/Sample - With this setting, Smart Count will guide the user through the counting procedure using the Tare -> Sample method.
- Sample/Tare - With this setting, Smart Count will guide the user through the counting procedure using the Sample -> Tare method.
- Handsfree - With this setting, Smart Count will guide the user through the counting procedure and will automatically tare the scale so that the user does not have to press the «→T←» key.

Note: User prompting should **not** be used in 2-scale counting.

Ref X		2-1-3
User Prompting	Min. Ref. WT Off	
Min. Ref. WT		
RefOpt		
▲	▼	▼ Edit Up End

Off		1/4
97.5%		
99.0%		
99.5%		
▼		OK Cancel

Minimum Reference Weight

This setting controls the limits for reference weight determination. If this function is active, the relative accuracy of the APW (see accuracy display) must be greater than the value selected. Otherwise, the user will be prompted to add more pieces to increase the value of the accuracy of the APW.

Ref X		2-1-4
User Prompting	RefOpt On	
Min. Ref. WT		
RefOpt		
▲	▼	▼ Edit Up End

Off		2/2
On		
▲		OK Cancel

Reference Optimization. See also Chapter 4.3 "Reference Optimization".

Activate Reference Optimization by choosing "On" or deactivate by choosing "Off".

User Prompting		2-1-5
Min. Ref. WT	Auto Ref. Det. Off	
RefOpt		
Auto Ref. Det.		
▲	▼	▼ Edit Up End

Off		1/2
On		
▼		OK Cancel

Auto Reference Determination

With this set to on, reference determination is automatically performed once load is placed on the scale without the user having to press the Ref_X softkey.

Activate auto sampling by choosing "On" or deactivate by choosing "Off".



Automatic Clear Average Piece Weight

With this set to on, the average piece weight is automatically cleared once the load is removed from the scale without the user having to press the «C» key.

Activate automatic clear average piece weight by choosing "On" or deactivate by choosing "Off".



Accuracy Display

This function enables the display of the percentage accuracy. With this function set to ON, the percentage accuracy will be displayed for approximately 4 seconds on the 4th Info line after a reference weight determination.

Activate accuracy display by choosing "On" or deactivate by choosing "Off".

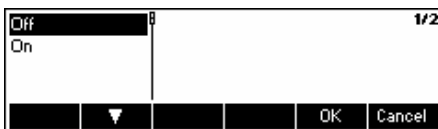

5.5.2 Settings for database (APPLICATION → Database)

The database settings allow the user to configure the operation of Smart Count while working with the article database and the Identification storage.

Please refer to Chapter 5.2 on how to reach the menu position 'Vision Setup → APPLICATION → Database' and how to navigate within the 'Vision Setup'-menu.



Press «>>» to go to database settings menu. Select the item that you wish to modify by using the «▼» and the «▲» keys. When the desired item is highlighted, press «>>» to modify the item.



- Article - Used for entering the article database.
- ID1 – ID3 - Used for identification purposes. If text is entered for the ID's they will be included in the printouts.



The following settings can be configured:

- Printout - Set the text that will serve as title for printouts.
- Softkey - Set the text that will appear on the softkey that is used to enter the articles database or to edit the selected ID.



The next settings are only for "Article":

- Search criterion - Set the field that will be used for searching, scrolling, and sorting of the list of articles in the database. It could either be by name or by number.
- Password - Password-protect the article database from being modified.

Note: Press the «Erase» key to clear the existing text and type the desired text using the keypad. Press the «→» and «←» keys to move cursor from left to right and vice-versa. Press the «OK» key when input is done. To deactivate the ID's, make their "Softkey" text blank (i.e. Press «Erase» then accept the empty text by pressing «OK»).

5.5.3 Settings for totalisation (APPLICATION → Totalisation)

These settings control the printout during the Totalisation function.

Please refer to Chapter 5.2 on how to reach the menu position 'Vision Setup → APPLICATION → Totalisation' and how to navigate within the 'Vision Setup'-menu.



Press «→» to go to Totalisation settings menu.

- Lot Printing - With this set to "Autoprint On", each lot is printed after it has been added to the total.



- Final Printing - With this set to "Autoprint On", there will be a printout of the total amount when the number of lots specified has been reached.

5.5.4 Settings for filling/checkweighing (APPLICATION → Filling/Checkweighing)

This setting controls the use of the built-in beeper during the Checkweighing (+/-) and Filling functions.

Please refer to Chapter 5.2 on how to reach the menu position 'Vision Setup → APPLICATION → Filling/Checkweighing' and how to navigate within the 'Vision Setup'-menu.



Press «Edit» to go to Filling/Checkweighing settings menu.



Press «Edit» to change settings of the Beeper. If the Beeper is set to on, there will be a short beep when the current load is within the target range.



Press «Edit» to change settings of the setpoint negative tolerance. Tolerance is shown in percent.



Press «**Edit**» to change settings of the mode of sending. Choices are either "Continuous" or "Stable".

5.5.5 Settings for softkey configuration (APPLICATION → Softkey Configuration)

This function configures the task of each softkey in the main display. There are a maximum of 30 definable softkeys, each of which can be configured to perform various applications and shortcuts to some scale operations.

Please refer to Chapter 5.2 on how to reach the menu position 'Vision Setup → APPLICATION → Softkey Configuration' and how to navigate within the 'Vision Setup'-menu.



Press «**Edit**» to go to Softkey Configuration settings menu.



Select the desired softkey that is to be defined and press «**Edit**» to designate its function. It is possible to define up to 30 softkeys.



Use the «**▼**» key and the «**▲**» key to select the desired function of the softkey then press the «**OK**» key.

Each softkey can be configured to any of the following functions:

- Not Used Select "Not Used" to indicate the last visible softkey. Softkeys with designated functions but are past the softkey set to "Not Used" will not be visible in the main display.
- Ref X Show the «**Ref X**» softkey where X is the reference number of pieces to use for average piece weight determination. The value for X can be defined in 'Vision Setup → APPLICATION → Counting → Ref X' (Chapter 5.5.1).
- Ref. n Show the «**Ref n**» softkey. With this softkey it is possible to select the reference number of pieces to use for average piece weight determination.
- Ref. APW Show the «**Ref APW**» softkey which is used to enter a pre-defined Average Piece Weight.
- Ref. Opt Show the «**RefOpt**» softkey which is used to perform a manual reference optimization (Chapter 4.3).
- Totalisation Show the «**Σ**» softkey which is be used to start the Totalisation application (Chapter 4.7).
- Checkweighing Show the «**+/-**» softkey which is used to start the Checkweighing application (Chapter 4.9).
- Filling Show the «**Filling**» softkey which is used to start the Filling application (Chapter 4.8).
- Factor/Unit Show the «**F/U**» softkey which is used to start the Factor/Unit application (Chapter 4.10).
- Weigh Count Show the «**Weigh**» (if scale is in piece counting mode) or «**Count**» (if scale is in weighing mode) softkey which is used to toggle the scale to weighing mode and piece counting mode respectively.
Note: If there is no average piece weight active, it will not be possible to switch modes so this softkey will not be visible even if it is configured.

52

Averageweighing	Show the « Average » softkey which is used to start the Average Weighing application (Chapter 4.11).
Additive Tare	Show the « AddTare » softkey which is used to add the current weight on the scale to the tare weight memory.
Multi Tare	Show the « MulTare » softkey. With this softkey, it is possible to enter the number of containers and the pre-determined tare weight of 1 container. Smart Count will automatically calculate the cumulative tare weight of the multiple containers.
Preset Tare	Show the « PT » softkey which is used to enter a pre-defined tare weight.
Gross	Show the « Gross » softkey which is used to show the gross weight on the main weight display.
Scale	Show the « ↕ » softkey which is used to toggle the weight source during 2-scale operations (Chapter 4.6). Note: This softkey will only be visible if 2-scale operations are possible. That means one of the interfaces must be set to a mode of "Reference Scale", "Bulk Scale", or "Auxiliary Scale" (Chapter 5.9.1).
High Res.	Show the « 0.1 » softkey which is used to display the net weight at a higher resolution.
Unit	Show the « Unit » softkey which is used to toggle the weight display between Unit1 and Unit2. Note: This softkey will only be visible if Unit1 and Unit2 (Chapter 5.4.2) are not the same.
Big Display	Show the « BigDis » softkey which is used to toggle the display between a large-font weight display and the normal weight display.
Save As Article	Show the « SaveAs » softkey. With this softkey, it is possible to save the current state of the applications into a new article.
Consecutive No	Show the « CNo » softkey. With this softkey, it is possible to edit the Consecutive Number which is incremented after every printout.
Invert	Show the « Invert » softkey which is used to invert the LCD display (Chapter 5.6.5).
Blank	Show a blank softkey.

5.5.6 Settings for Info/Help (APPLICATION → Info/Help)

This function configures the contents of the four Info lines located at the left side of the main display. The info lines can be accessed by pressing the «**i**» key while in the main display.

Please refer to Chapter 5.2 on how to reach the menu position 'Vision Setup → APPLICATION → Info/Help' and how to navigate within the 'Vision Setup'-menu.

Totalisation					2-6
Filling/Checkw.	Info 1	Gross Wt.			
Softkey Config	Info 2	Date			
Info/Help	Info 3	Time			
▲	▼	▼	Edit	Up	End

Press the «**Edit**» key to enter the list of available Info that can be designated for each Info line.



Each Info line can be configured to display any of the following information:



- Not Used Display a blank Info line.
- Gross Wt. Display the gross weight.
- Date Display the date.
- Time Display the time.
- Accuracy Display the percentage accuracy. This line will only be displayed if a reference weight determination has been performed.
- Zoom Display the net weight at a higher resolution.
- Timeout Display the timeout status.
- Consecutive No. Display the current value of the Consecutive Number.
- ID1 ... ID3 Display the entry for the IDs. You can only select this if the IDs have been set up in 'Vision Setup → APPLICATION → Database → ID1-ID3' (Chapter 5.5.2).

5.5.7 Settings for reset (APPLICATION → Reset)

This function resets the 'APPLICATION' block to its original factory settings.

Please refer to Chapter 5.2 on how to reach the menu position 'Vision Setup → APPLICATION → Reset' and how to navigate within the 'Vision Setup'-menu.



Press «**Yes**» to reset the application settings. 'SURE?' will appear, press «**Yes**» to confirm. The application settings are now reset to its original factory settings.

5.6 Terminal settings for device (TERMINAL → Device)

This function block allows the user to change display and peripheral oriented settings of the scale. Only the "Device" block is available to the user.

Please refer to Chapter 4.2 on how to reach the menu position 'Vision Setup → TERMINAL → Device' and how to navigate within the 'Vision Setup'-menu.

54



The screen shows the most important terminal settings as a preview.



The screen shows a preview of the most important settings of the active item, e.g. those of device if 'Device' is active (i.e. highlighted).

Enter the TERMINAL menu («>>») and choose one of the functions listed below.

Available functions and settings:

Language settings	→ Chapter 5.6.1
Sleep function	→ Chapter 5.6.2
Backlight	→ Chapter 5.6.3
Contrast	→ Chapter 5.6.4
Invert	→ Chapter 5.6.5
Weight display	→ Chapter 5.6.6
Date and time	→ Chapter 5.6.7
Beep	→ Chapter 5.6.8

5.6.1 Language settings (TERMINAL → Device → Language)

This function allows the user to change the language settings of the scale.

Please refer to Chapter 5.2 on how to reach the menu position 'Vision Setup → TERMINAL → Device → Language' and how to navigate within the 'Vision Setup'-menu.



Press the «Edit» key to go to the Language settings menu.



Use the «▼» key and the «▲» key to select the desired language setting and press the «OK» key.

5.6.2 Sleep function (TERMINAL → Device → Sleep)

When the balance is deriving its power only from a battery and is not plugged in an electrical outlet, this function is especially useful in order to conserve power.

Please refer to Chapter 5.2 on how to reach the menu position 'Vision Setup → TERMINAL → Device → Sleep' and how to navigate within the 'Vision Setup'-menu.



Press the «Edit» key to go to the Sleep settings menu.

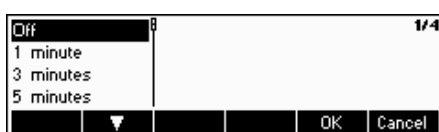

The balance will turn itself off automatically when the selected time elapses.

5.6.3 Turning off the backlight (TERMINAL → Device → Backlight)

Switch the backlight on or off. This function is again useful when conserving power, if the balance is deriving its power from a battery. Please note however that without the backlight, it is difficult to see the display. If the display becomes too dark to see when you select "Off", immediately press on the 2nd softkey to switch the backlight on again.

Please refer to Chapter 5.2 on how to reach the menu position 'Vision Setup → TERMINAL → Device → Backlight' and how to navigate within the 'Vision Setup'-menu.



Press the «**Edit**» key to go to the Backlight settings menu.



Switch on or off and then press the «**OK**» key.

5.6.4 Adjusting the contrast of the display (TERMINAL → Device → Contrast)

This function allows the user to adjust the contrast of the screen display.

Please refer to Chapter 5.2 on how to reach the menu position 'Vision Setup → TERMINAL → Device → Contrast' and how to navigate within the 'Vision Setup'-menu.



Press the «**Edit**» key to go to the Contrast settings menu.



Select the degree of contrast by scrolling the «**▼**» key or the «**▲**» key. Press the «**OK**» key to confirm selection.

5.6.5 Invert (TERMINAL → Device → Invert)

This function allows the user to select either a white or a black background of the screen display.

Please refer to Chapter 5.2 on how to reach the menu position 'Vision Setup → TERMINAL → Device → Invert' and how to navigate within the 'Vision Setup'-menu.



Press the «**Edit**» key to go to the Invert settings menu.

Choose the desired setting (Yes or No) and then press the «**OK**» key to confirm selection.

5.6.6 Changing the size of weight display (TERMINAL → Device → Weight display)

This function allows the user to select either a small or a big weight display on the screen.

Please refer to Chapter 5.2 on how to reach the menu position 'Vision Setup → TERMINAL → Device → Weight display' and how to navigate within the 'Vision Setup'-menu.



Press the «**Edit**» key to go to the Weight Display settings menu. Default setting is big.

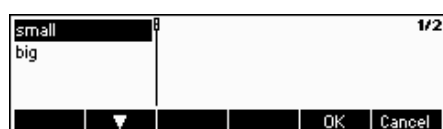

Choose the desired size and then press the «**OK**» key to confirm selection.

Note: Changing the mode of the weight display with the «**BigDis**» softkey (Chapter 5.5.5) will not affect this setting. If the mode was changed with the «**BigDis**» softkey, the display will revert to this setting after switching the balance on or after leaving the Vision Setup.

5.6.7 Adjusting the date and time (TERMINAL → Device → Date Time)

This function allows the user to set date and time of the balance.

Please refer to Chapter 5.2 on how to reach the menu position 'Vision Setup → TERMINAL → Device → Date Time' and how to navigate within the 'Vision Setup'-menu.



Press the «**Edit**» key to go to the Date and Time settings menu.

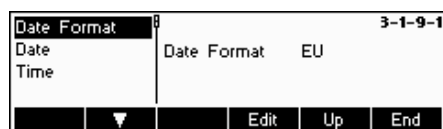

Press the «**Edit**» key to change format either from US or EU format. Select Date to change the date and Time to change the clock of the balance. Press «**OK**» key to confirm selection.

5.6.8 Activating the beep (TERMINAL → Device → Beep)

This function allows the user to switch the beep on or off, that is appearing on each key press.

Please refer to Chapter 5.2 on how to reach the menu position 'Vision Setup → TERMINAL → Device → Beep' and how to navigate within the 'Vision Setup'-menu.



Press the «**Edit**» key to go to the Beep settings menu.

Choose the desired setting (On or Off) and then press the «**OK**» key to confirm selection.

5.7 Define supervisor password (TERMINAL → Access)

This function allows the user to change the supervisor password of the scale. Can only be accessed by a supervisor.

Please refer to Chapter 5.2 on how to reach the menu position 'Vision Setup → TERMINAL → Access' and how to navigate within the 'Vision Setup'-menu.



Press the «>>» key ...



... and then press the «Edit» key to enter a new password.

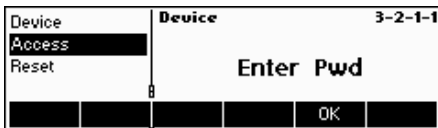

Enter the password using the keypad, press «Ok» to confirm. 'Retype Pwd' appears. Retype the new password and press «Ok» again.

If the password was forgotten, you may press «→0←», «→0←», «→0←», «» keys in sequence to access the Vision Setup.

5.8 Reset terminal settings to factory settings (TERMINAL → Reset)

This function resets the 'TERMINAL' block to its original factory settings. The supervisor password ('TERMINAL → Access') will not be reset, only "Device" block.

Please refer to Chapter 5.2 on how to reach the menu position 'Vision Setup → TERMINAL → Reset' and how to navigate within the 'Vision Setup'-menu.



Press «Yes» to reset the terminal settings. 'SURE?' will appear, press «Yes» to confirm. The terminal settings are now reset to its original factory settings.

5.9 Communication settings (COMMUNICATIONS)

This function block allows the user to change the peripheral settings of the scale. Differences will appear depending on the option pack installed. Can only be accessed by a supervisor.

Please refer to Chapter 4.2 on how to reach the menu position 'Vision Setup → COMMUNICATIONS' and how to navigate within the 'Vision Setup'-menu.

SCALE		Overview		4	
APPLICATION	Com1	Printer			
TERMINAL	Com2	Dialog			
COMMUNICATIO	Com3	Dialog			
▲		▼		»	
		Up		End	

The screen shows the most important communication settings as a preview.

Com1		4-1	
Com2	Mode	Printer	
Com3	Baud	9600	
PS2	Parity	8-none	
▼		»	
		Up	
		End	

The screen shows a preview of the most important settings of the active item, e.g. those of COM1 if 'Com1' is active (i.e. highlighted).

Enter the COMMUNICATION menu («>>»), select a COM port and choose one of the functions listed below.

Available functions and settings:

Mode	→ Chapter 5.9.1
Parameters	→ Chapter 5.9.2
Define string – if mode is Printer or Auto print	→ Chapter 5.9.3
Add Line Feed	→ Chapter 5.9.4
Define I/O – if mode is Digital I/O	→ Chapter 5.9.5
Reset 'COMMUNICATION' settings to factory settings	→ Chapter 5.9.6
Option Settings	→ Chapter 5.9.7
PS2 settings	→ Chapter 5.9.8

5.9.1 Mode (COMMUNICATIONS → Mode)

This function enables the user to set the input/output mode of a COM port.

Please refer to Chapter 5.2 on how to reach the menu position 'Vision Setup → COMMUNICATIONS → Mode' and how to navigate within the 'Vision Setup'-menu.

Mode		Com1		4-1-1	
Parameters	Mode	Dialog			
Reset Com					
▼		Edit		Up	
				End	

Press the «Edit» key to go to the Mode settings menu.

Printer		Com1		4/11	
Auto Print					
Cont Weight					
Dialog					
▲		▼		»	
		OK		Cancel	

The mode setting can be changed to either **Printer, Auto Print, Continuous Weight, Dialog, 2nd Display, Reference Scale, Bulk Scale, Auxiliary Scale, Toledo Weight, Toledo Count** or **Digital I/O**. In this example, Com1 was set to Dialog (also known as host mode for SICS commands).

Press the «End» key and confirm with the «Yes» key to save the changes.

5.9.2 Parameters (COMMUNICATIONS → Parameters)

Please refer to Chapter 5.2 on how to reach the menu position 'Vision Setup → COMMUNICATIONS → Parameters' and how to navigate within the 'Vision Setup'-menu.

Mode		Com1		4-1-2	
Parameters	Baud	2400			
Define String	Parity	7-even			
Add LineFeed	Handshake	✕on✕off			
▲		▼		»	
		Up		End	

The current Baud Rate, Parity and Handshake settings are displayed on the screen. Press «>>» and ...



... «Edit» to change settings of Baud, Parity or Handshake.

Baud:	Parity:	Handshake:
300	7-none	No
600	7-odd	XonXoff
1200	7-even	Net 422
2400	8-none	Net 485
4800	8-odd	
9600	8-even	
19200		
38400		
115200 (Only for COM3)		

Note: If Handshake "Net 422" or "Net 485", a Net Address menu will appear from which you can select from 0...31.

If Mode is "Toledo Weight" or "Toledo Count", a Checksum menu will appear which you can turn either "Off" or "On". If checksum is turned "On", the values transmitted through the interface can be verified by means of a checksum.

5.9.3 Define string (COMMUNICATIONS → Def. String – only if Mode is Printer or Auto Print)

This function allows customizing the printer output. Note that this function is only available if Mode is Printer or Auto Print.

Please refer to Chapter 5.2 on how to reach the menu position 'Vision Setup → COMMUNICATIONS → Def. String' and how to navigate within the 'Vision Setup'-menu.

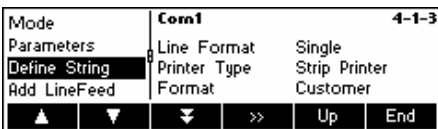

The current settings are displayed on the screen. Press «>>» and ...



Line Format menu: Choose Single or Multiple. For normal print-outs, 'Single' is recommended.

'Single' = 1 result per line. 'Multiple' = all results on one line.



Printer type menu: Choose 'Strip Printer' (e.g. 24 char/line strip printer Sprinter 1) or 'A4 Printer' (Epson LX-300).

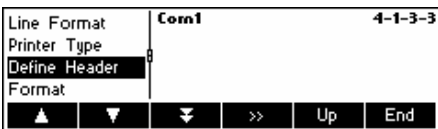

Define Header menu: Press «>>» to specify the header of the printout.



Select the header line and press «Edit» key and type in the header using the keypad or attached keyboard.



Format menu: The appearance of the printout may be altered according to the specifications of the user. To do so, choose 'Customer' rather than 'Standard'. If Customer is selected, press the «>>» key to go to the 'Line Available' menu to customize the lines to be printed out.

60

Line 1	Com1	4-2-3-5
Line 2	Data	Article
Line 3	Font	Standard
Line 4		
<div style="display: flex; justify-content: space-between; align-items: center;"> ▼ ▼ >> Up End </div>		

Browse the line numbers 1-23 and edit the lines according to your needs.

5.9.4 Add LineFeed (COMMUNICATIONS → Add LineFeed)

This feature is used to add an empty Line Feed on the printout right after each report. The default settings is 4 lines, meaning 4 empty lines are generated right after each report, to make it more convenient for the user to detach the printed output from the printer.

Please refer to Chapter 5.2 on how to reach the menu position 'Vision Setup → COMMUNICATIONS → Add LineFeed' and how to navigate within the 'Vision Setup'-menu.

Mode	Com1	4-1-4
Parameters	4	
Define String		
Add LineFeed		
<div style="display: flex; justify-content: space-between; align-items: center;"> ▲ ▼ ▼ Edit Up End </div>		

... when this screen appears, press the «**Edit**» key to change the Add LineFeed settings menu.

1	Com1	5/10
2		
3		
4		
<div style="display: flex; justify-content: space-between; align-items: center;"> ▲ ▼ ▼ OK Cancel </div>		

Press the «**▼**» and «**▲**» keys to choose the desired number of lines and then press the «**OK**» key to confirm changes.

5.9.5 Define I/O (COMMUNICATIONS → Def. I/O – only if Mode is Digital I/O)

This function defines commands sent by Smart Count to the LC-I/O during Checkweighing and Filling functions. Note that this function may only be activated if Mode is Digital I/O.

Please refer to Chapter 5.2 on how to reach the menu position 'Vision Setup → COMMUNICATIONS → Def. I/O' and how to navigate within the 'Vision Setup'-menu.

Mode	Com1	4-1-5
Parameters	< Tol-	W1 02 0
Define I/O	Good	W1 04 0
Reset Com	> Tol+	W1 08 0
<div style="display: flex; justify-content: space-between; align-items: center;"> ▲ ▼ >> Up End </div>		

Choose < **Range-**, < **Tol-**, **Good**, > **Tol+**, >**Range+**, **Output off** or **Reset I/O** and then press the «**Edit**» key to define the commands.

< Range-	Com1	4-1-5-1
< Tol-	W1 01 0	
Good		
> Tol+		
<div style="display: flex; justify-content: space-between; align-items: center;"> ▼ ▼ Edit Up End </div>		

< **Range-** The command to send if the weight is below plausible limits.

< **Tol-** The command to send if the weight is below the Tol-defined.

Good The command to send if the weight is within the tolerances defined.

> **Tol+** The command to send if the weight is above the Tol+ defined.

> **Range+** The command to send if the weight is above plausible limits.

5.9.6 Reset communications (COMMUNICATIONS → Comx → Reset Com)

This function resets the 'COMMUNICATIONS' block to its original factory settings.

Please refer to Chapter 5.2 on how to reach the menu position 'Vision Setup → COMMUNICATIONS → Comx → Reset Com' and how to navigate within the 'Vision Setup'-menu.



Press «**Yes**» to reset the settings of the current Com port. 'SURE?' will appear, press «**Yes**» to confirm. The chosen Com port is now reset to its original factory settings.

5.9.7 Option Settings (COMMUNICATIONS → Option)

This function allows setting up the attached analog option. **Available only if analog option is installed.**

Please refer to Chapter 5.2 on how to reach the menu position 'Vision Setup → COMMUNICATIONS → Def. String' and how to navigate within the 'Vision Setup'-menu.



The current settings are displayed on the screen. Press «**OK**» and ...



Press the «**Edit**» key to change the mode of the analog option input.



Choose **Reference Scale, Bulk Scale, Auxiliary Scale or Bypass** and then press the «**OK**» key to select the desired mode.

- Reference Scale-** The weight coming from the analog option is to be used for reference weight determination only.
- Bulk Scale** The weight coming from the analog option is to be used as bulk weight only.
- Auxiliary Scale** The weight coming from the analog option can be used as either reference or bulk.
- Bypass** The weight coming from the analog option will be ignored.

5.9.8 PS2 Settings (COMMUNICATIONS → PS2)

This function allows setting up of the peripherals that are attached via the PS2 Interface.



Select the item you wish to configure.

62

**Keyboard**

It is possible to attach a PS2 keyboard to the balance via the PS2 Interface. This function enables you to specify the layout of the keyboard that you are using.

Note: When a PS2 keyboard is attached, it is possible to work with Smart Count using only this keyboard. The keys F1-F6 simulate the softkeys, F9-F11 simulate the top 3 function keys of the Viper scale. You can press the «**Enter**» and «**Esc**» keys to simulate the «**OK**» and «**Cancel**» softkeys respectively. The «**Backspace**» key simulates the «**C**» key.

**BCR**

Aside from a keyboard, it is also possible to attach a barcode reader via the PS2 Interface. This function enables you to specify the designation of the data coming from the barcode reader used for Direct Input (i.e. when the scale is in weighing or piece counting mode).

Not Used	Ignore data coming from the barcode reader.
Article Search	Use the data for searching through the article database.
Tare Wt.	Assign the data read to Tare weight.
APW	Assign the data read to Average Piece Weight.
ID1	Assign the data read to ID1.
ID2	Assign the data read to ID2.
ID3	Assign the data read to ID3.

Note: The BCR setting is only used for Direct Input. Whenever the scale is asking for user input, the barcode reader can also be used to scan in data and the data will be used in the context of the user input.

5.10 Diagnostic settings (DIAGNOSTICS)

This function block allows the user to verify if all keys are functioning properly. Can only be accessed by a supervisor.

Please refer to Chapter 5.2 on how to reach the menu position 'Vision Setup → DIAGNOSTICS' and how to navigate within the 'Vision Setup'-menu.

APPLICATION	Overview		5
TERMINAL	Keyboard	US Internat.	
COMMUNICATI	Displ.Type	White	
DIAGNOSTICS	Max. Articles	311	
▲	▼	>>	Up End

Enter the DIAGNOSTICS menu («>>») and choose one of the functions listed below.

Available functions and settings:

- Keyboard Test → Chapter 5.10.1
- Display Test → Chapter 5.10.2
- Serial Number 1 → Chapter 5.10.3
- Serial Number 2 → Chapter 5.10.4
- List1 → Chapter 5.10.5
- List2 → Chapter 5.10.6
- List Memory → Chapter 5.10.7
- Reset All → Chapter 5.10.8

5.10.1 Keyboard (DIAGNOSTICS → Keyboard Test)

Please refer to Chapter 5.2 on how to reach the menu position 'Vision Setup → DIAGNOSTICS → Keyboard Test' and how to navigate within the 'Vision Setup'-menu.

Keyboard Test	Start?	5-1
Display Test		
SNR1		
SNR2		
▼	Yes	Up End

In order to check if all the keys are functioning properly, press «Yes» to start the keyboard test.

Keyboard Test	PUSH 1	5-1
Display Test		
SNR1		
SNR2		
▼	Yes	Up End

Press all 25 keys in sequence. If a key is functioning, the scale jumps to the next key. The keys are numbered as follows:

5	6	7	8	9	10	11	12	13
1	2	3	4	14	15	16		
				17	18	19		
				20	21	22		
				23	24	25		

5.10.2 Display (DIAGNOSTICS → Display Test)

Please refer to Chapter 5.2 on how to reach the menu position 'Vision Setup → DIAGNOSTICS → Display Test' and how to navigate within the 'Vision Setup'-menu.

Keyboard Test	Start?	5-2
Display Test		
SNR1		
SNR2		
▲	▼	Yes Up End

In order to check if the screen is functioning properly, press «Yes» and...



... appears on the screen.

5.10.3 Serial Number 1 (DIAGNOSTICS → SNR1)

Please refer to Chapter 5.2 on how to reach the menu position 'Vision Setup → DIAGNOSTICS → SNR1' and how to navigate within the 'Vision Setup'-menu.

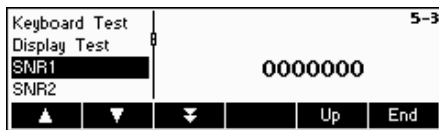

The serial number of the scale is displayed

5.10.4 Serial Number 2 (DIAGNOSTICS → SNR2)

Please refer to Chapter 5.2 on how to reach the menu position 'Vision Setup → DIAGNOSTICS → SNR2' and how to navigate within the 'Vision Setup'-menu.



The serial number of the analog option, if it is installed, is displayed.

5.10.5 List 1 (DIAGNOSTICS → List 1)

Please refer to Chapter 5.2 on how to reach the menu position 'Vision Setup → DIAGNOSTICS → List 1' and how to navigate within the 'Vision Setup'-menu.



Press «Yes» to print out the current settings of the whole Vision Setup menu.

5.10.6 List 2 (DIAGNOSTICS → List 2)

Please refer to Chapter 5.2 on how to reach the menu position 'Vision Setup → DIAGNOSTICS → List 2' and how to navigate within the 'Vision Setup'-menu.

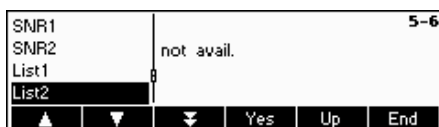

Press «Yes» to print out the current settings of analog option, if it is installed.

5.10.7 List memory (DIAGNOSTICS → List Memory)

This function prints out a listing of all the articles stored in the database including a summary of the important parameters for each article.

Please refer to Chapter 5.2 on how to reach the menu position 'Vision Setup → DIAGNOSTICS → List Memory' and how to navigate within the 'Vision Setup'-menu.



Press the «**2**» key to go to the List Memory settings menu and press the «**Yes**» key to start.

5.10.8 Reset All (DIAGNOSTICS → Reset All)

This function resets the all blocks of the whole Vision Setup Menu to its original factory settings. The supervisor password ('TERMINAL → Access') will not be reset.

Please refer to Chapter 5.2 on how to reach the menu position 'Vision Setup → DIAGNOSTICS → Reset All' and how to navigate within the 'Vision Setup'-menu.



Press the «**2**» key to go to the List Memory settings menu and press the «**Yes**» key to reset all.

6 *Other important information*

This Chapter gives information on error messages and instructions for cleaning your scale. It also includes the declaration of conformity and technical data.

6.1 Error messages

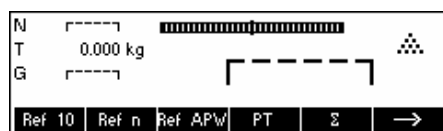

Overload

Reduce the load on the scale or the preload.



Underload

Place weighing pan on the scale and ensure that it can move freely.

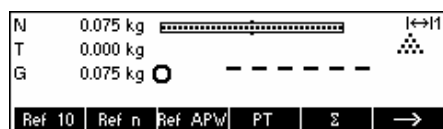

Weight reading does not stabilize

- Ensure a tranquil environment.
- Ensure that the weighing pan is free to move.
- Change the setting of the vibration adapter (Chapter 5.4.6)



Not possible to zero scale

Ensure that the zeroing is only carried out in the permissible range and not under overload or underload conditions.



Reference weight too low

The weight placed on the pan is too small to define a valid reference weight for piece counting. Place a larger number of reference pieces on the scale.

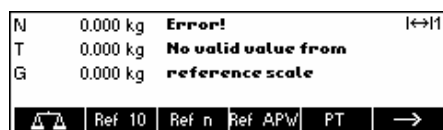

No valid value from reference scale

This message is only given when piece counting with a 2-scale system. Check the connecting cable between the scales and the interface settings.

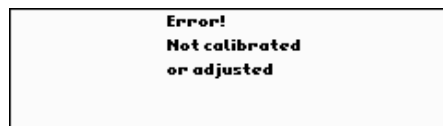

No calibration/adjustment

Disconnect the power cord plug and then plug it in again. (If operating on the battery, switch the scale off and then on again.) If the error message reappears, calibrate/adjust the scale (Chapter 5.4.1). If this does not help, contact your dealer or local representative.

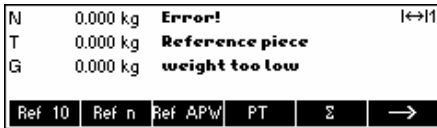

Reference piece weight too small

When defining the reference weight, the scale has found that the resultant weight of one single piece is below the permissible limit. Piece counting is not possible for articles as small as this.



Unstable weight when determining the reference weight

When determining the reference weight, the reading did not stabilize, and the scale therefore cannot determine the reference weight of a single piece.

1. Ensure a tranquil environment.
2. Ensure that the weighing pan is free to move.
3. Change the setting of the vibration adapter (Chapter 5.4.6).



EAROM checksum error

Disconnect the power cord plug and then plug it in again. (If operating on the battery, switch the scale off and then on again.) If the error message reappears, contact your dealer or local representative.



Chain Tare not allowed

Chain Tare is deactivated in the Vision Menu ('Vision Setup → SCALE → Tare → Chain Tare'). This means it is not possible to tare the balance once there is already a value in the tare memory.



Pushbutton Tare not allowed

The scale cannot be tared using the «→T←» key because this feature was deactivated in the Vision Setup ('Vision Setup → SCALE → Tare → Pushb. Tare').



Key not allowed in short input mode

The function softkey that was pressed while in Short Input Mode (Chapter 3.1) is not compatible with Short Input Mode.

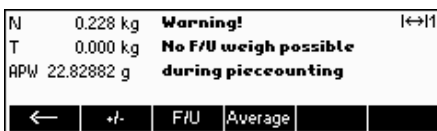

Factor/Unit weighing not possible

The application Factor/Unit weighing (Chapter 4.10) cannot be started while the balance is in piece counting mode. Either press the «Weigh» key to switch to weighing mode or press «C» to clear the APW which should automatically switch the balance to weighing mode.

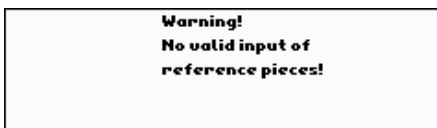

No valid input of reference pieces

The reference number of pieces that was entered via «Ref n» → «Var» or Short Input Mode → «Ref n» was invalid. The reference weight determination will not be performed.

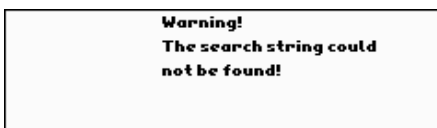

Search string not found

This warning appears if the bar code reader was configured for article searching ('Vision Setup → COMMUNICATIONS → PS2 → BCR') and the text read in by the bar code reader was not found in the article database.

6.2 Sample reports

Weigh mode

(c) Mettler-Toledo GmbH
http://www.mt.com

Date 17.07.2002
Time 15:28:12

G 0.0370 kg
T 0.2843 kg
N 0.3213 kg

Count mode

(c) Mettler-Toledo GmbH
http://www.mt.com

Date 17.07.2002
Time 15:13:51

G 0.4122 kg
T 0.0630 kg
N 0.3492 kg

Piece Wt 14.11524 g
Out of 10 PCS
QUANTITY 25 PCS

Weigh mode with article

(c) Mettler-Toledo GmbH
http://www.mt.com

Caramel 1365
Toffee Factory
000124245672

Date 17.07.2002
Time 15:32:32

G 0.6549 kg
PT 0.0630 kg
N 0.5919 kg

Count mode with article

(c) Mettler-Toledo GmbH
http://www.mt.com

English Toffees 1060
Toffee Factory
000124254467

Date 17.07.2002
Time 13:46:50

G 0.3980 kg
PT 0.0630 kg
N 0.3350 kg

Piece Wt 3.450000 g
QUANTITY 97 PCS

6.3 Cleaning instructions



Disconnect the scale from the power supply before cleaning it!

Use a damp cloth (do not use acids, alkalis or strong solvents).

Wet cleaning is only allowable on scales with IP65 ingress protection.

If heavily contaminated, the weighing pan, protective cover (if fitted) and adjustable feet must be removed and cleaned separately.

With the weighing pan removed, never use a solid object to clean underneath the load plate support!

Observe your organization's internal rules and industry-specific regulations for cleaning intervals and permissible cleaning agents.

70

Total weight	Small platform:	line-voltage scale:	Stain gauge	MonoBloc
		AccuPac scale:	4.6 kg	4.7 kg
	Large platform:	line-voltage scale:	5.2 kg	5.3 kg
		AccuPac scale:	8.2 kg	10.5 kg
		AccuPac scale:	8.8 kg	11.1 kg
Ingress protection	IP43 (optional IP65 (EN 60529) for scales with strain gauge cells. These scales are identified with an IP65 adhesive label.)			
Standard delivery package	Complete scale (terminal and weighing platform assembled) Operating instructions Open-end wrench (for leveling)			

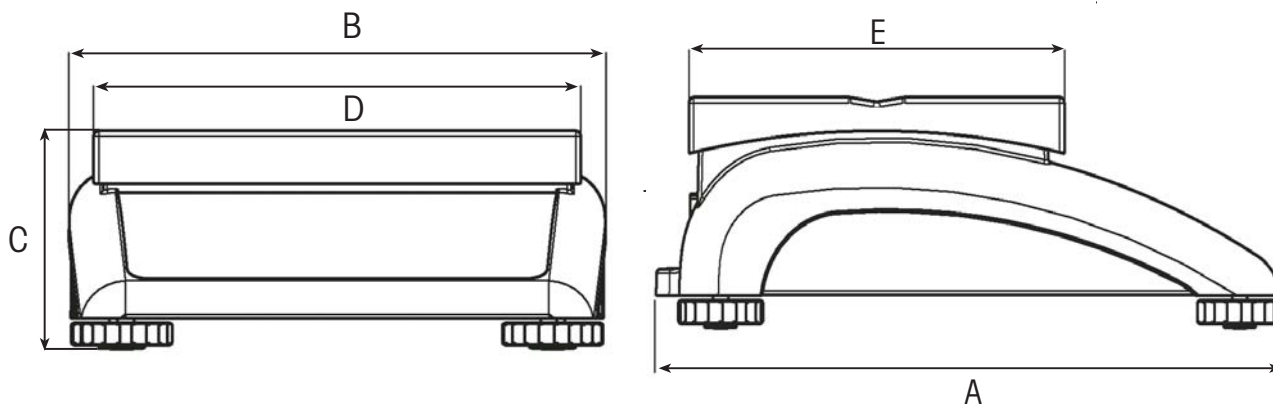
7.2 Dimensions

	A	B	C*	D	E
Small platform	335	265	110	240	200
Large platform	370	360	115	350	240

All dimensions in millimeters

* with adjustable feet fully screwed in

7.3 Interface technical data

The scale is provided with an EIA RS-232C (CCITT V24/V.28) voltage-controlled interface as standard. Maximum cable length is 15 m. All interfaces are in the form of a 9-pin D-sub female connector. Instructions for configuring the interfaces are given in Chapter 5.9.2.

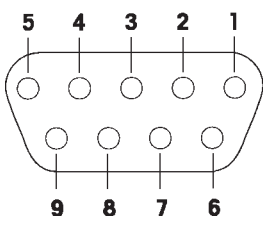
Interface		1 (standard)	2 (standard)	3 (standard)	optional
Type		RS232C	RS232C	RS232C	Analog
Pin assignment 	Pin 1	---	---	---	+ Excitation (+8.2V)
	Pin 2	TxD	TxD	TxD	+ Sense
	Pin 3	RxD	RxD	RxD	Shield
	Pin 4	---	---	---	- Sense
	Pin 5	GND	GND	GND	- Excitation (GND)
	Pin 6	---	---	---	---
	Pin 7	---	---	CTS	+ Signal
	Pin 8	---	---	RTS	- Signal
	Pin 9	VCC	VCC	VCC	---

TxD: Transmit data

RxD: Receive data

GND: Signal ground

VCC: Power supply +5V

Technical data for 'Analog' option:

A/D-Converter ('analog' option)	Load cell (weighing bridge to be connected to analog option)
Resolution (approved): 7'000 e	Power supply: 8.2 V
Resolution (not approved): 300'000 d	Impedance: 80 -1'000 R
Input signal (approved): 1.3 μ V/e	Output signal: 2 mV/V

7.4 Accessories

	Article No.
Auxiliary display RS-PD/PASM	21302875
RS232 cable for auxiliary display 1.8m (9-pin D-Sub, m/m parallel)	21250066
Protective cover for small platform scale	21203207
Protective cover for large platform scale	21203206
Antitheft device	00229175
"Sprinter 1" printer, EURO version	21253399

"Sprinter 1" printer, UK version	21253745
RS232 cable for printer 1.8m (25/9-pin D-Sub, m/m crossover)	21253677
RS232 cable for 2nd scale 1.8m (9-pin D-Sub, m/m, crossover)	21252588
RS232 cable for PC 1.8m (9-pin D-Sub, m/f, parallel)	00410024

7.5 Interface commands

Your scale can be configured and operated, and can communicate from a PC via RS232C interface.

7.5.1 Preconditions

The following preconditions must be fulfilled to achieve communication between the scale and a PC:

- The scale must be connected to the RS232C interface of the PC using the necessary cable.
- The scale interface must be set in "Dialog" mode (see Chapter 5.9.1).
- A terminal program must be available on the PC (e.g. "Hyper Terminal").
- The communications parameters (protocol, bits and parity, data transfer rate) must be set using the same values in the terminal program and in the scale (see Chapter 5.9.2).

7.5.2 SICS Command set

Your scale basically supports the **Mettler Toledo Standard Interface Command Set (MT-SICS)**. The SICS command set used are "Level 0", "Level 1", and some "Level 2" commands. Detailed information on the interface commands is given in the "MT SICS Reference Manual" (No. 705184, only available in English).

Notes:

- Every command line must be terminated with **<CR><LF>** (corresponding to the "Enter" or "Return" key on the PC keyboard). The command is then executed immediately. To correct a line, this needs to be entered again completely.
- For commands with parameters, the "_" symbol signifies an empty space, and in the examples given, serves solely to clarify the syntax.
- For commands that require text parameters, the quotation marks must be entered, as they indicate to the scale that they enclose a text string and not another parameter.

The following lists the supported MT-SICS commands:

I0	Inquiry of all implemented MT-SICS commands.
I1	Inquiry of MT-SICS level and MT-SICS versions.
I2	Inquiry of balance data.
I3	Inquiry of balance software version.
I4	Inquiry of serial number.
S	Send stable weight value.
SI	Send weight value immediately irrespective of balance stability.
SIR	Send weight values repeatedly irrespective of balance stability.

Z	Zero the balance.
ZI	Zero the balance immediately irrespective of balance stability.
@	Reset the balance to condition after switching on but without a zero setting being performed.
D	Write text into balance display. (E.g. D_`text`).
DW	Switch back to weight display after D command.
K	Configure key control.
SR	Send current stable weight value and then continuously on weight change equal to or greater than the preset value. (E.g. SR_10.00_g).
T	Tare the balance.
TA	Inquire or preset the tare weight value.
TAC	Clear the tare value.
TI	Tare immediately regardless of whether the current value is stable or not.
C2	Initiate calibration.
I10	Inquire or set the balance ID.
I11	Inquiry of balance type.
DAT	Inquire or set the date on the balance.
P100	Print out text on the printer. (E.g. P100_`text`).
P101	Print out current stable weight value.
P102	Print out current weight value irrespective of balance stability.
PWR	Switch the balance on or off.
ST	Send stable weight after pressing the  key.
TIM	Inquire or set the time on the balance.
SU	Send stable weight value with currently displayed unit.
SIU	Send weight value with currently displayed unit immediately irrespective of balance stability.
SIRU	Send weight value with currently displayed unit immediately and repeat.
SRU	Send stable weight value with currently displayed unit and repeat on weight change greater than or equal to preset value.

Aside from the standard MT-SICS commands, Smart Count also provides the following commands for working with the balance:

M01	Inquire or set the weighing mode ('Vision Setup → SCALE → Filter → Process': Chapter 5.4.6).	
	M01	Inquiry of weighing mode.
	M01_0	Set weighing mode to "Universal".
	M01_1	Set weighing mode to "Filling".
M03	Inquiry or setting of AutoZero ('Vision Setup → SCALE → Zero → Auto Zero': Chapter 5.4.4).	
	M03	Inquiry of AutoZero mode.
	M03_0	Set "AutoZero" to off.
	M03_1	Set "AutoZero" to on.
M09	Inquiry or setting of display contrast ('Vision Setup → TERMINAL → Device → Contrast': Chapter 5.6.4)	
	M09	Inquiry of display contrast.
	M09_x	Set the display contrast to x% where x can have a value of 0-100.

- I31 Inquire or define the record header for printouts.
- I31_x Inquiry the definition for the x header line.
I31_x_“text” Define the text for a specific header line where:
x 1..5
text String of characters with a maximum of 24 characters.
- Example: I31_1_“Mettler Toledo GmbH”
I31_2_“Heuwinkelstrasse”
I31_3_“CH-8606 Naenikon”
I31_4_“Telefon 01/944 22 11”
I31_5_“Internet www.mt.com”
- SWU Switch the displayed unit from “Unit1” to “Unit2” and vice versa.
- PRN Initiate a printout of the current stable weight or number of pieces.
- ICP Configure customer-defined printout (“Vision Setup → COMMUNICATIONS → Def. String”: Chapter 5.9.3).
- ICP_? Send this command to get a response from the balance with details about how to use the ICP MT-SICS command.
- SIH Send the current weight value displayed in control mode, i.e. with a higher resolution, immediately irrespective of balance stability.

7.6 Declaration of conformity

We, **Mettler-Toledo (Albstadt) GmbH, Unter dem Malesfelsen 34, D-72458 Albstadt** declare under our sole responsibility that the product

Viper Smart from serial no. 2511380,

to which this declaration relates, is in conformity with the following directives and standards:

Directive	Applicable standard
Relating to electrical equipment designed for use within certain voltage limits (73/23/EEC; amended by directive 93/68/EEC)	EN61010-1 (Safety Regulations)
Relating to electromagnetic compatibility (89/336/EEC; amended by directive 93/68/EEC; 92/31/EEC)	EN61326-1
Relating to non-automatic weighing instruments (90/384/EEC; amended by directive 93/68/EEC) ¹⁾	EN45501 ¹⁾ (Metrological Aspects) 

¹⁾ Applies only to certified scales (approved/tested certificate no. T5508 for scales with strain gauge cells, T5627 for scales with "MonoBloc" cells).

Albstadt, July 2002

Mettler-Toledo GmbH

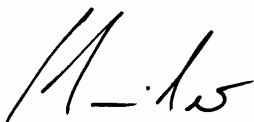

Roland Schmider, General Manager



Heiko Carls, Quality Manager

Important notice for verified weighing instruments in EC countries

Weighing instruments verified at the place of manufacture bear the preceding mark on the packing label and a green "M" sticker on the descriptive plate. They may be set to work immediately.



Weighing instruments which are verified in two steps have no green "M" on the descriptive plate and bear the preceding identification mark on the packing label. The second step of the verification must be carried out by the approved Mettler-Toledo service or by the W&M authorities. Please contact your Mettler-Toledo organization.

The first step of the verification has been carried out at the manufacturing plant. It comprises all tests according to EN45501-8.2.2.

If national regulations in individual countries limit the period of validity of the certification, the operator of such a scale is himself responsible for its timely re-certification.

USA/Canada

This equipment has been tested and found to comply with the limits for a Class A digital device, pursuant to both Part 15 of the FCC Rules and the radio interference regulations of the Canadian Department of Communications. These limits are designed to provide reasonable protection against harmful interference when the equipment is operated in a commercial environment. This equipment generates, uses and can radiate radio frequency energy and, if not installed and used in accordance with the instruction manual, may cause harmful interference to radio communications. Operation of this equipment in a residential area is likely to cause harmful interference, in which case the user will be required to correct the interference at his own expense.

Cet appareil a été testé et s'est avéré conforme aux limites prévues pour les appareils numériques de classe A et à la partie 15 des règlements FCC et à la réglementation des radio-Interférences du Canadian Department of Communications. Ces limites sont destinées à fournir une protection adéquate contre les interférences néfastes lorsque l'appareil est utilisé dans un environnement commercial. Cet appareil génère, utilise et peut radier une énergie à fréquence radioélectrique ; il est en outre susceptible d'engendrer des interférences avec les communications radio, s'il n'est pas installé et utilisé conformément aux instructions du mode d'emploi. L'utilisation de cet appareil dans les zones résidentielles peut causer des interférences néfastes, auquel cas l'exploitant sera amené à prendre les dispositions utiles pour palier aux interférences à ses propres frais.

78**Index****2**

2nd display	58
2-scale	28, 43

A

accumulation total gross weight	21
accumulation total net weight	21
accumulation total number of lots	21
accumulation total number of pieces	21
accuracy display	49
additive tare	52
analog option	61
article database	18, 49
article identification	19, 49
article name	19
article number	19
article sample size	20
article tare weight	20
auto print	58
auto sampling	48
auto zero	45
automatic clear average piece weight	49
automatic clear tare	45
automatic reference optimization	26
automatic tare	45
automatic taring	23
autoprint	50
auxiliary scale	28, 52, 58, 61
average piece weight	17, 20, 23, 26, 27, 49, 51
average weighing	33, 52
average weight	33

B

backlight	55
bar graph	30
barcode reader connection	62
battery	10
baud rate	59
beep	56
beeper	50
big display	52
blank info line	53
blank softkey	52
bulk scale	28, 52, 58, 61
bypass	61

C

calibration	44
chain tare	45
checksum	59
checkweighing	31, 50, 51
communication	28, 57, 58, 61
consecutive number	52
consecutive number info line	53
continuous weight	58

contrast	55
Count key	24

D

database	49, 50
date	27
date and time	11, 56
date info line	53
dependent mode	48
dialog	58
digital I/O	58
display	11, 28, 32
display test	63
ditigal I/O	60

E

empty line feed	60
-----------------------	----

F

factor	32
factor/unit weighing	31, 51
filling	30, 51
filling/checkweighing lower limit	21
filling/checkweighing nominal value	20
filling/checkweighing upper limit	20
final printing	50
fine range	30

G

gross weight	16, 27, 52
gross weight info line	53

H

Handsfree	48
handshake	59
header	59
high resolution info line	53
HighRes - softkey	52

I

independent mode	48
Info line	52, 54, 55, 56
Info/Help key	27, 52
interface	16, 24, 28
invert	52, 55

K

keyboard connection	62
keyboard test	63

L

language	12, 54
line format	59
lot printing	50

Index**M**

manual reference optimization	26, 51
minimum reference weight	26, 48
mode settings	58
multi range scale	45
multi tare	52

N

negative tolerance	30, 31
net weight	16

P

parity	59
password	34, 35, 50, 57
percentage accuracy	26, 27
percentage accuracy info line	53
piece counting mode	51
piece weight lower limit	20
piece weight optimization	20
piece weight upper limit	20
positive tolerance	30, 31
power cord plug	10
preset tare	52
pre-tare	15
pre-tare weight	17
printer	16, 24, 29, 58
printout	49, 59, 64, 65
push button tare	45

R

range symbol	13
reference	23
reference number	51
reference optimization	26
reference scale	28, 52, 58, 61
reference weight	23
reference weight determination	17, 26
reset	47, 53, 57, 61, 65
resolution	32, 44, 45

S

Sample/Tare	48
save as article	52
Save As Article function	21
search criterion	50
serial number	64
short-input mode	17
sleep function	54, 74
softkey	49, 51
softkey configuration	51
stability detector	13
summary report	30

T

tare	14
tare memory	45
tare weight	15

tare weight memory	52
Tare/Sample-	48
target weight	30, 31
time	27
time info line	53
timeout status	53
Toledo Count	58
Toledo Weight	58
tolerance limits	30, 31
totalisation	29

U

unit	32
unit - toggle Unit1 / Unit2	52
user prompting	48

V

vibration settings	46, 49, 50, 51
--------------------------	----------------

W

Weigh key	24
weighing mode	51
weighing range	13
weight display size	56

Z

zeroing	11
---------------	----

For the future benefit of your METTLER TOLEDO product, and to preserve its value, METTLER TOLEDO service assures you of its quality and measuring accuracy for years to come. Please request full details of our attractive terms of service. Thank you.



Subject to technical changes.
Printed on 100% chlorine-free paper.
For the sake of our environment.