

# Operating instructions

## METTLER TOLEDO MultiRange ID3s-A weighing terminal

**METTLER TOLEDO**

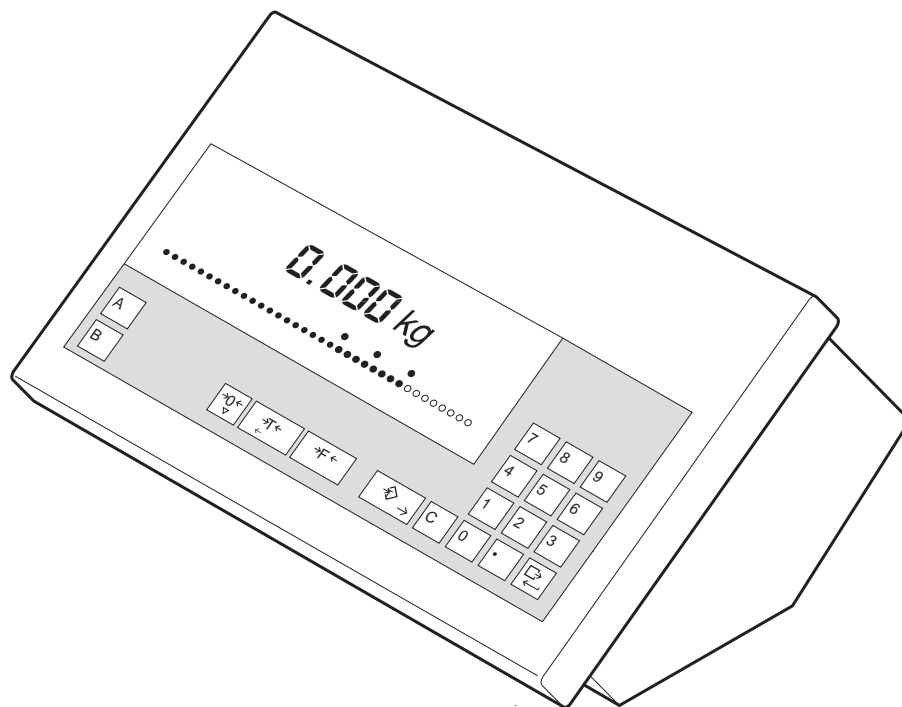



<b>Contents</b>	<b>Page</b>
<b>1 Cautionary notes .....</b>	<b>2</b>
<b>2 Putting into operation .....</b>	<b>2</b>
2.1 General information .....	2
2.2 Attaching the weighing platform to the terminal .....	3
2.3 Connecting weighing terminal to power supply .....	4
2.4 Labels on weighing terminal and sealing .....	5
<b>3 Overview of instrument .....</b>	<b>6</b>
3.1 Layout of the weighing terminal .....	6
3.2 Display .....	6
3.3 Keypad .....	7
<b>4 Operation .....</b>	<b>9</b>
4.1 On/off switching .....	9
4.2 Zero setting .....	9
4.3 Taring .....	10
4.4 Designations and identifications .....	11
4.5 Weighing .....	12
4.6 Testing the scale .....	12
<b>5 Applications .....</b>	<b>13</b>
5.1 Plus/minus weighing .....	13
5.2 Gross recall .....	17
5.3 Counting .....	18
5.4 Formula weighing .....	19
5.5 Totalization .....	20
5.6 Unit switching .....	21
5.7 Dynamic weighing .....	21
5.8 Display with enhanced readability .....	22
<b>6 Master mode .....</b>	<b>23</b>
6.1 General information .....	23
6.2 Overview of the master mode blocks .....	24
<b>7 Service mode .....</b>	<b>37</b>
7.1 General .....	37
7.2 Operation of the service mode .....	37
7.3 Settings in the service mode .....	39
<b>8 Application blocks .....</b>	<b>43</b>
<b>9 Appendix .....</b>	<b>47</b>
9.1 What if...? .....	47
9.2 Cleaning .....	48
9.3 Technical data .....	48
9.4 Optional equipment .....	50
9.5 Geo value table .....	51

## 1 Cautionary notes



- ▲ Never operate the weighing terminal in hazardous areas. We offer instruments in our product range with the appropriate types of protection for use in hazardous areas.
- ▲ As the weighing terminal can be made dead only by disconnecting the power plug, it may be connected only to a readily accessible receptacle outlet in the vicinity of its location.
- ▲ Before putting into operation, ensure that the line voltage matches the voltage printed on the label on the weighing terminal.
- ▲ Attachment of the weighing platform to the weighing terminal only by authorized METTLER TOLEDO service or as described in these instructions.
- ▲ The weighing terminal may be opened only for attachment of the weighing platform and only by a qualified electrician.

## 2 Putting into operation

### 2.1 General information

Setting up and putting into operation of the weighing terminal and weighing platform is normally performed by the METTLER TOLEDO customer service.

If you wish to install the weighing terminal yourself, follow the procedure described in these instructions.

If you wish to operate the already attached weighing platform in a configuration other than the standard configuration, you can change this setting in the service mode, see section 7. After a change in the configuration, the scale must be recertified, see section 2.4.

## 2.2 Attaching the weighing platform to the terminal

### Opening terminal

- Disconnect power plug.
- Unscrew 2 screws on the underside of the cover at the front and lift off cover.
- Disconnect keypad cables and weighing platform cable on the main board on the right next to the display.
- Detach heavy gauge cable gland from power cable connection and push in power cable by about 5 cm.
- Unscrew 2 screws on the main board, lift main board out of the guide and place to the front.
- Remove locking pin of the sealing sleeve for the weighing platform connection and detach heavy gauge cable gland for the weighing platform connection.

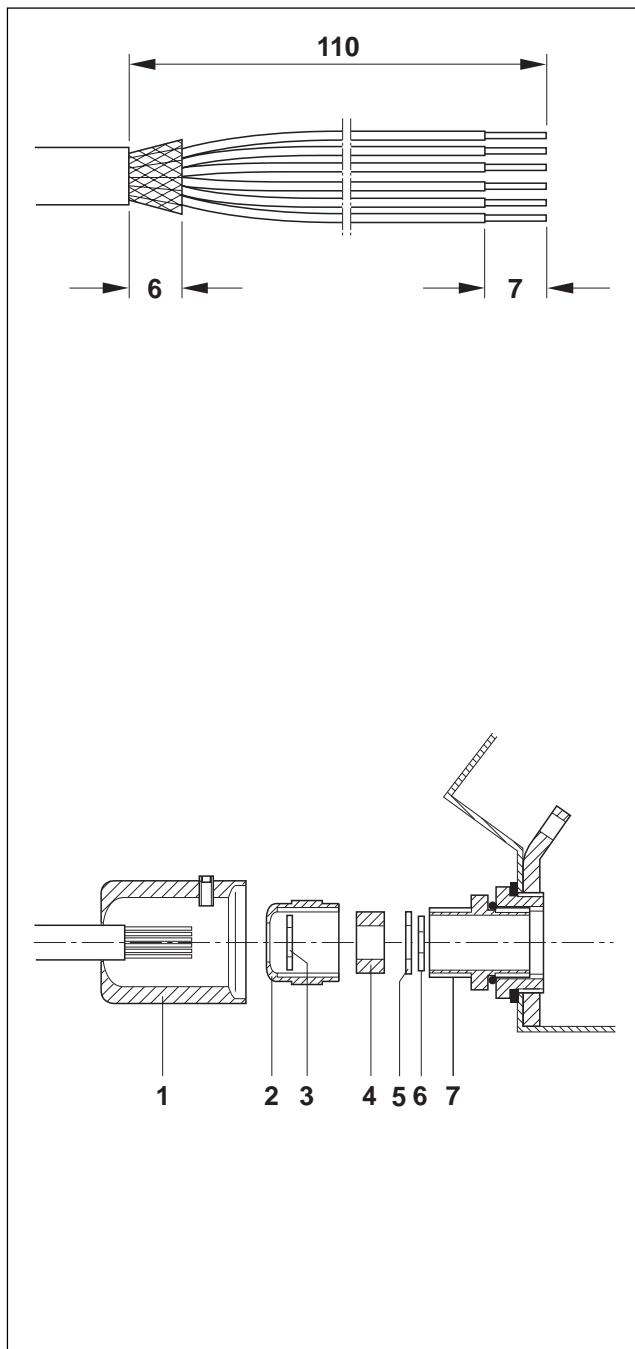

### Preparing weighing platform connection cable

- Remove approx. 110 mm insulation from cable ends.
- Shorten cable shield to 6 mm.
- Remove approx. 7 mm insulation from wire ends and twist together.
- Mount wire end ferrules and press tight with crimping tool.

#### Caution

The wire ends must not protrude beyond the wire end ferrules.

### Attaching cable gland to the weighing platform cable

#### Note

Shielding measures against noise irradiation and noise emission are particularly important with long connection cables. The maximum interference immunity classes are achieved only with careful and correct installation and wiring of all attached peripheral devices and weighing platforms. It is absolutely necessary to connect the screening expertly and on both sides. The CE-conformity of the whole system rests in the responsibility of the person who takes it into operation.

- Push sealing sleeve (1), compression nut (2), washer (3), molded seal (4) and contact washer with large hole (5) over the cable jacket.

#### Caution

If wires of the braided shield become loose, they must not come into contact with electrically conducting system parts.

- Unravel the exposed shield.
- Push molded seal (4) and contact washer (5) up to the edge of the cable jacket and lay shield in place.
- Push contact washer with small hole (6) over the wire leads so that the shield is between the two contact washers.
- If the shield wires are longer than the diameter of the contact washers, shorten shield wires to the diameter of the contact washers.
- Insert molded seal with cable in the anti-rotation element of the metal housing (7).
- Screw compression nut onto metal housing, but do not tighten it yet.

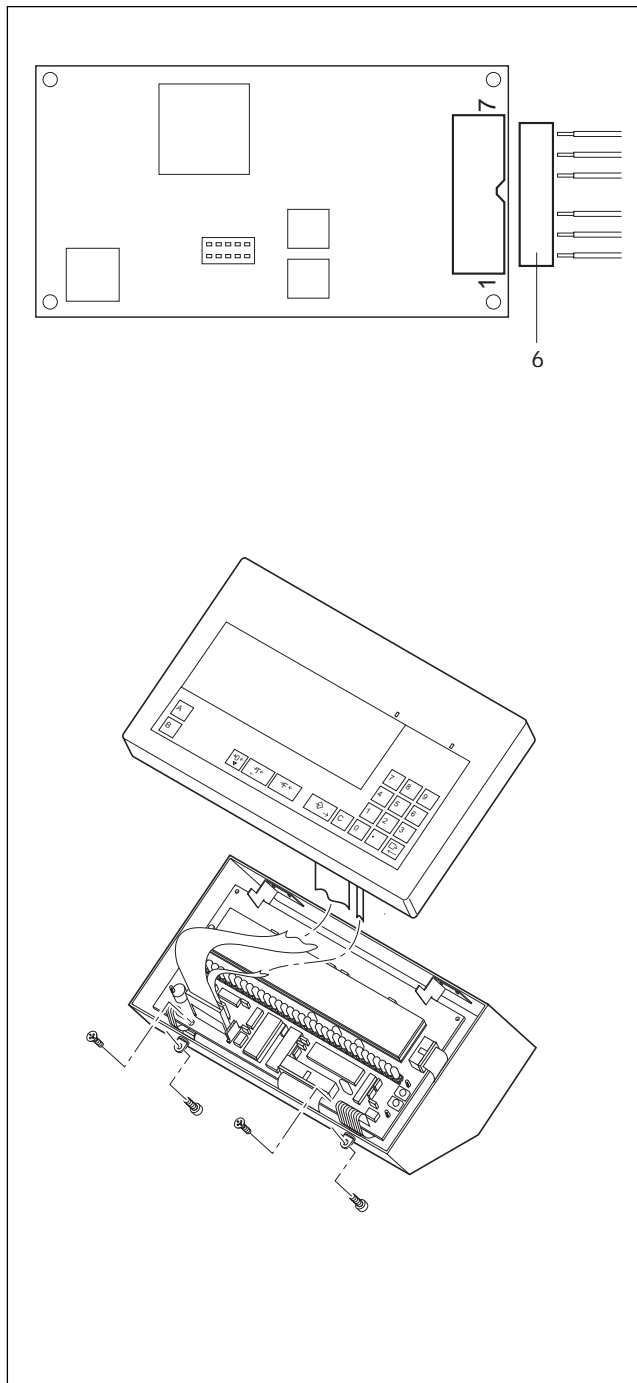

**Connecting cable**

- Disconnect connector (6) from analog board.
- Connect the conductors of the weighing platform cable to the connector terminals as follows:

Pin	Assignment	Color with METTLER TOLEDO analog weighing platforms		
		multiple cell version D...-T, N...-T RWM SPIDER large	single cell version DB...T DCC...T	SPIDER small
1	+ EXC	grey	blue	green
2	+ SEN	yellow	green	blue
3	+ SIG	white	white	red
4	–	–	–	–
5	– SIG	brown	red	white
6	– SEN	green	grey	brown
7	– EXC	blue	black	black

**Note**

If the cable of the weighing platform to be attached has only 4 wires, the following two pairs of terminals must be connected by a jumper:

- Terminals 1 and 2 (+EXC and +SEN)
- Terminals 6 and 7 (–SEN and –EXC)

- Plug connector into analog board.
- Tighten heavy gauge cable gland.
- Attach sealing sleeve and secure with locking pin. The sealing sleeve must turn easily.

**Closing terminal**

- Plug cable of analog board into main board.
- Pull power cable outward and tighten heavy gauge cable gland.
- Insert main board in the guide and install with 2 screws.
- Plug both keypad cables into main board.
- Mount cover and tighten with 2 screws on the underside of the cover at the front.

**2.3 Connecting weighing terminal to power supply**

- Ensure that the line voltage matches the voltage value on the model plate of the weighing terminal.
- Unload weighing platform.
- Connect weighing terminal to the power supply.
- Switch on weighing terminal: press any key.

## 2.4 Labels on weighing terminal and sealing

An identification code can be used with certified scales to check whether any alterations have been made to the weighing platform since the last certification. The identification code can be shown on the terminal at any time.

In the certification, the weighing terminal is provided with an identification code sticker which must match the identification code shown in the display. This identification code sticker is sealed with a verification mark. In addition, the weighing platform connection is sealed with a verification mark on the locking pin of the sealing sleeve.

Each time the configuration is changed, the displayed identification code increases and then no longer matches the affixed, sealed identification code; the certification is thus no longer valid.

### Displaying identification code

- Press the  key until "CODE = ...." is displayed.

With noncertified scales, no value is shown, but "CODE ===" appears.

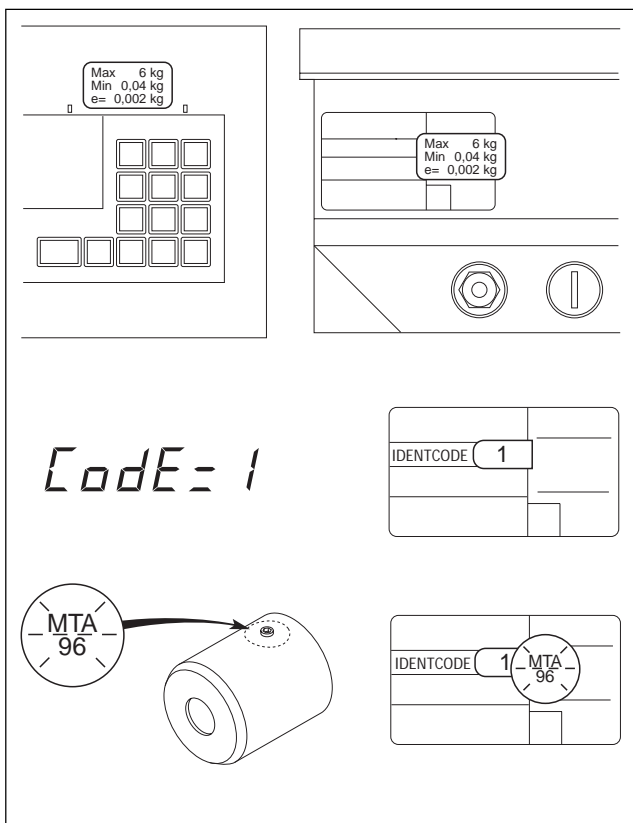

### Affixing configuration data plate

- On the cover.
- On the measurement data plate at the rear of the terminal.

### Affixing identification code sticker

- On the measurement data plate at the rear of the terminal, with certified scales the affixed identification code must match the identification code shown by the terminal.

### Affixing verification marks

- On the identification code.
- On the locking pin of the sealing sleeve.

### 3 Overview of instrument

#### 3.1 Layout of the weighing terminal

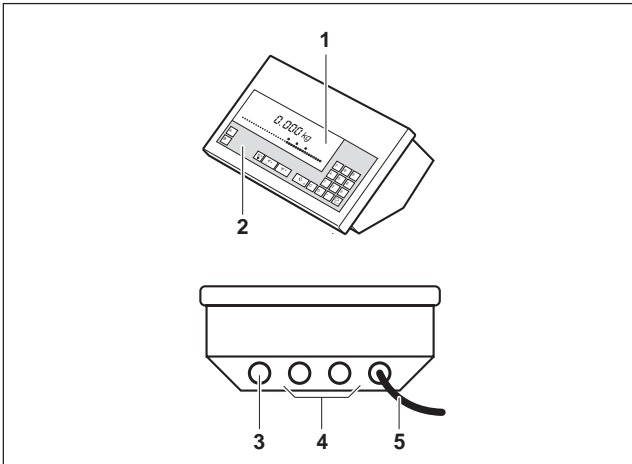

The weighing terminal comprises the following components:

- 1** Display
- 2** Keypad
- 3** Weighing platform connection
- 4** Interface connection (optional)
- 5** Power cable

#### 3.2 Display

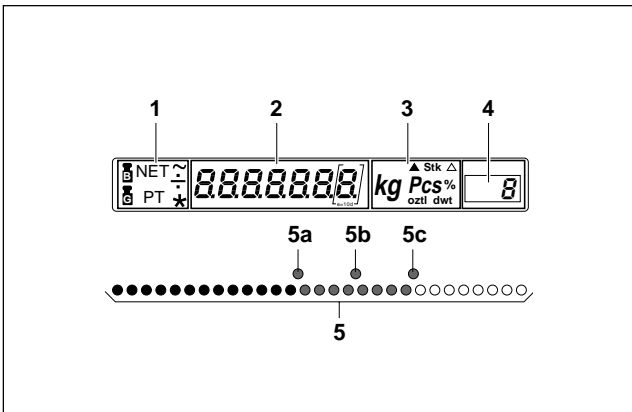

The display unit comprises 5 display groups:

- 1** Field for display of the weight statuses
- 2** 7-place digital display
- 3** Field for display of the weight unit and special symbols
- 4** Field for display of the class
- 5** LED analog display for plus/minus weighing
- 5a** Lower tolerance marker
- 5b** Target value marker
- 5c** Upper tolerance marker



### 3.3 Keypad

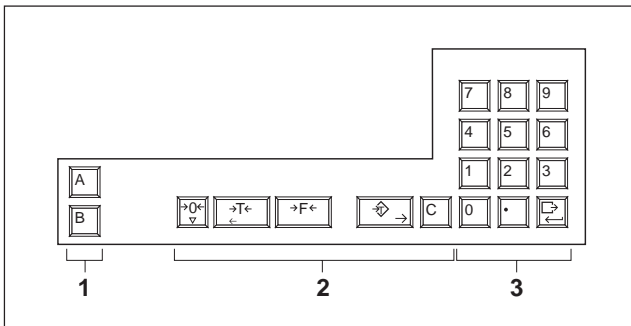

- 1 Keys for entry of identifications, e.g. article or order No.
- 2 Keys for the weighing operation
- 3 Numeric keypad with enter key

Key	Main function Press key briefly	Auxiliary function Press and hold key until <b>2nd</b> beep	Press and hold key until <b>3rd</b> beep
<b>Code keys</b> A B	Entry of identifications	Selection of the designation	
<b>Zeroing key/test key</b> →0← ▽	Manual zero setting of the scale	Display of identification code; check on the calibration and the display unit	Switch off terminal
<b>Tare key</b> →T← ←	Taring of the scale; cursor key in entry of code A, B; NO in the master mode		On/off switching of automatic taring
<b>Tare entry key</b> ↕→	Select tare entry; cursor key in entry of code A, B		
<b>Clear key</b> C	Correction of wrong entry		Clear active function (counting, formula weighing, totalization, dynamic weighing)
<b>Decimal point</b> .	Entry of tare and entry of code A, B; entry of preset special characters for code A or B	Switch special characters entered with the decimal point key: decimal point, dash or space. From current preset character cyclically – to the next	– to the next but one
<b>Enter key/ transfer key</b> ↵	Close entry; retain total; YES in the master mode; transfer of data to the data interface		Select master mode

<b>Key</b>	<b>Main function</b> Press key <b>briefly</b>	<b>Auxiliary function</b> Press and hold key until <b>2nd</b> beep	Press and hold key until <b>3rd</b> beep
<b>Function key</b>	Depending on assignment of the function key in the master mode:		
			
PLUSMIN	Enter target value, tolerances and start point of scale or limit 1 and limit 2, or accept weighed values	Recall fixed target value memory	Load fixed target value memory
GROSS	Gross recall		
COUNT	Display of weight or piece number determination	Reference piece number entry	Select reference
FORMUL	Formula weighing	Display of weight, total or item counter	Print out total and clear; retain total
TOTAL	Totalization	Display of weight, total or item counter	Print out total and clear; retain total
UNIT	Unit switching	Selection of 2nd unit	Gross recall
DYNAMIC	Dynamic weighing	Display of weight, total or item counter	Print out total and clear; retain total
CONTROL	Weight display with normal or enhanced readability		

## 4 Operation

### 4.1 On/off switching

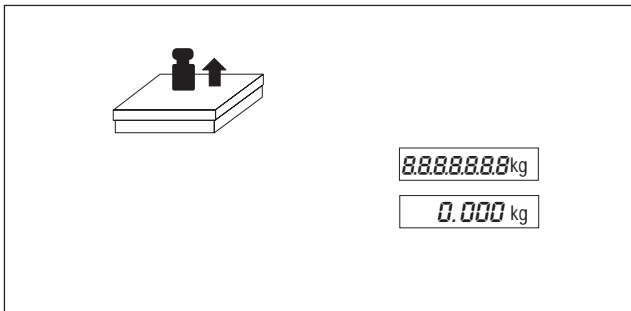

#### Switching on

- Unload weighing platform.
- Press any key and wait until "0.000 kg" appears in the display.

#### Switching off

- Press and hold  until the display fades.

#### Automatic shutdown

The weighing terminal switches itself off automatically if no weighing has been performed for 10 minutes. The automatic shutdown must be set in the master mode for this.

### 4.2 Zero setting

Zero setting corrects the weight of minor amounts of contaminants on the load plate. With severe contamination which can no longer be compensated by zero setting, NO appears in the display.

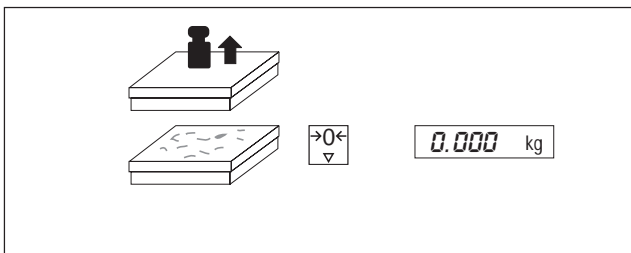

#### Manual zero setting

- Unload weighing platform.
- Press zeroing key briefly.

### 4.3 Taring

The weighing platform stores only one tare value. If a tare value is stored, it is displayed with a negative sign when the weighing platform is unloaded.

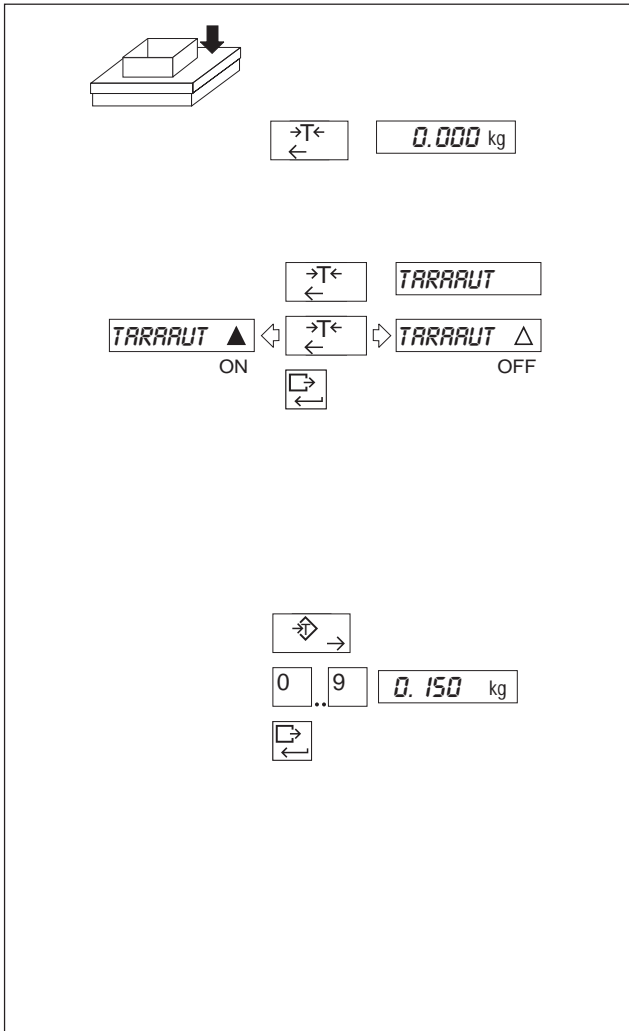

#### Manual taring

- Load empty container.
- Press tare key.

Clearing stored tare value:

- Unload weighing platform.
- Press tare key.

#### Switching automatic taring on/off

Preset: Automatic taring off. If the automatic taring is switched on, "Manual taring" and "Preset tare" are not possible.

- Press and hold the tare key until AUTTARA appears in the display.
- Switch on/off with the tare key and confirm with the enter key.

Clearing automatically stored tare value:

- Unload weighing platform.

#### Preset tare

- Press tare entry key.
- Enter known tare weight using the numeric keypad and confirm with the enter key.

Clearing preset tare value:

Either

- Unload weighing platform.
- Press tare key

or

- enter tare "0".

or

- Press tare entry key.
- Press clear key.

## 4.4 Designations and identifications

Memories for weighing data are assigned to the code keys A and B. Each memory has a name (the designation) and a content (the identification) which can be accessed with the key.

For instance, pressing the A key can recall "Article 272-54" from the memory (designation is "Article", identification "272-54").

An **identification** comprises max. 18 characters. Possible characters are numbers and special characters (decimal point, dash or space).

- To switch between decimal point, dash and space as a special character, press and hold the decimal point key until the 2nd or 3rd beep.

The setting changes cyclically. The selected setting of the special character applies until the next change.

Possible **designations** are: Article (preset designation for key A), Order (preset designation for key B), Code, Formula, Ident, Number, Comp. (and a freely selectable designation if a serial interface is attached).

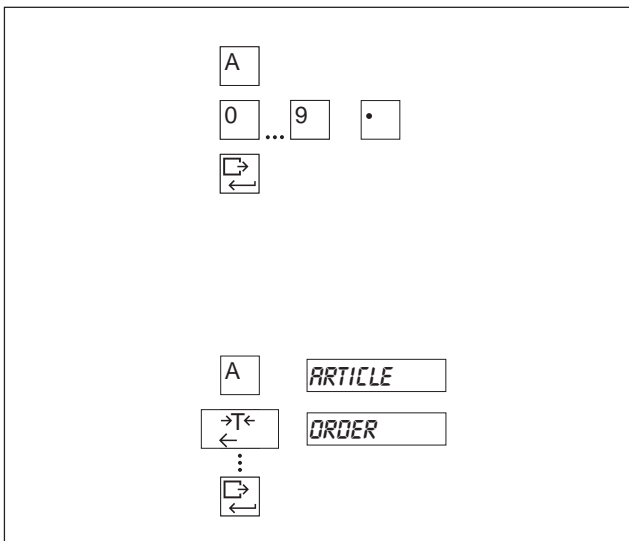

### Entering identification

- Press code key A (B).
- Enter identification via the numeric keypad or decimal point key and confirm with the enter key.

### Changing identification

- Press code key A (B). The display shows the last 5 positions.
- Move the cursor to the left/right using the tare/tare entry key and overwrite the desired position.

### Selecting designation

- Press and hold code key A (B) until the first designation appears in the display.
- Select the desired designation by pressing the tare key repeatedly and then confirm with the enter key.

### 4.5 Weighing

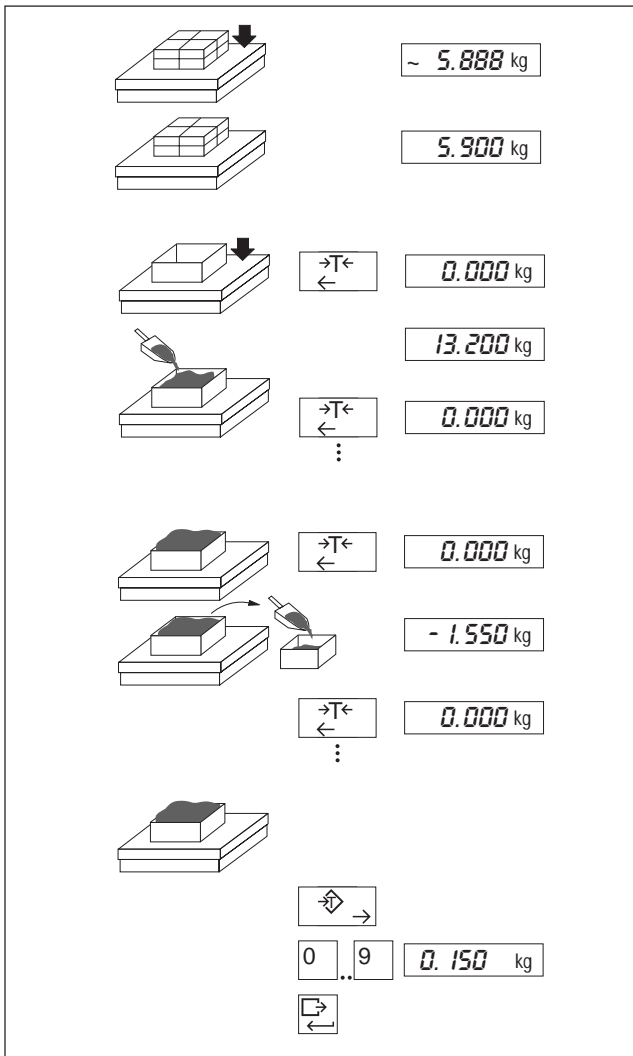

#### Weighing

- Load weighing sample and wait for stability.
- Read off weight.

#### Weighing-in

- Tare empty container.
- Add desired amount.
- Tare.
- Add additional quantity, tare, etc.

#### Subtractive weighing (weighing-out)

- Tare full container.
- Remove desired amount.
- Tare.
- Remove a further quantity, tare etc.

#### Determining net weight

- Load full container.
- Press tare entry key.
- Enter known tare weight and confirm with the enter key. The arrows in the display symbol flash during the entry. With an inadmissible tare weight, NO appears in the display.

### 4.6 Testing the scale

▲ When testing the scale, avoid ambient conditions (vibrations, drafts) which could cause disturbance.

▲ In legal applications, the identification code shown in the display must match the code on the ident (identification) card.

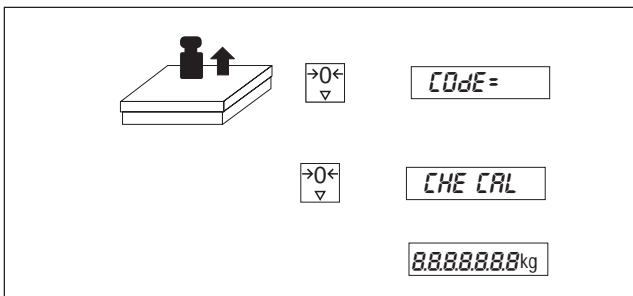

- Unload weighing platform.
- Press the test key until "Code = " appears in the display.

If a calibration error (CAL ERR) is displayed in the internal test, repeat test. If the error message reappears, inform customer service.

Internal test O.K.:

- All segments light up briefly, the scale then returns to the weighing mode.

## 5 Applications

### 5.1 Plus/minus weighing

In plus/minus weighing, three different applications can be selected in the master mode. Target values or class limit values in frequent use can be stored in the fixed value memories.

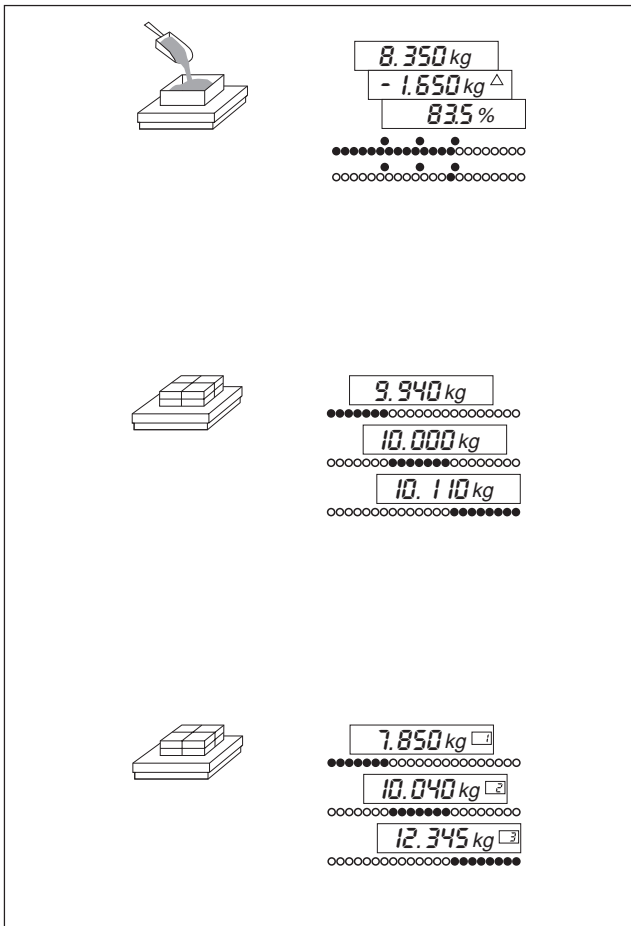

#### Weighing-in

Filling to a preset target weight.

Digital display shows either

- actual weight,
- difference to target weight or
- actual weight in % of target weight.

LED analog display shows either

- luminescent band or
- luminescent dot.

#### Checking

Testing whether the actual weight lies within preset tolerances of the target weight.

Digital display shows either

- actual weight,
- difference to target weight or
- actual weight in % of target weight.

LED analog display shows

- too little, good, too much.

#### Classifying

Test objects are sorted into 3 weight classes.

Digital display shows

- actual weight with class No.

LED analog display shows

- class 1/class 2/class 3.

#### Accepting or entering values

All values can be taken over from a reference weight or entered by the numeric keypad.

Accept weighed values of a reference weight: Use the enter key to move the cursor to the extreme right until the weight unit flashes. Load weight.

### 5.1.1 Loading and recalling fixed value memories

There are 25 fixed value memories which can be employed for values in frequent use: for target values in weighing-in and checking, for class limit values in classifying.

#### Note

Switching to a different application clears the fixed value memories.

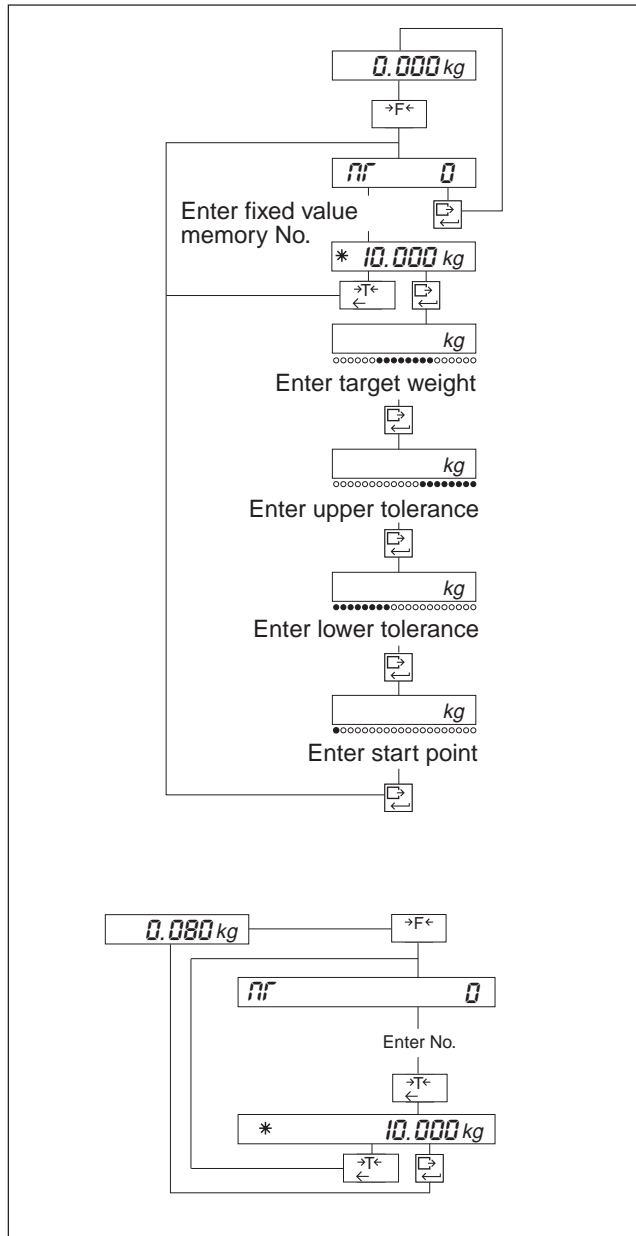

#### Loading fixed value memories

- Press function key until NR is displayed.

Entry for each fixed value memory (confirm entry each time with the enter key):

- Memory No. (1...25). If the memory is already occupied, the target weight is displayed with the symbol \*. Activate the enter key for loading the fixed value memory or return to the number entry with the tare key.
- Target weight in weighing-in and checking. Limit 1 in classifying.
- Upper tolerance in weighing-in and checking. Limit 2 in classifying.
- Lower tolerance in weighing-in and checking.
- Start point in weighing-in. In checking and classifying, the value entered in the master mode as zero limit will be used.

#### Recalling fixed value memories

Only occupied fixed value memories can be recalled, if the memories are not occupied NO is displayed.

- Press and hold the function key until the 2nd beep. The display switches to "- - - -".
- Enter number of the fixed value memory. The target value is displayed with the symbol \*.
- Activate fixed value memory with the enter key or return to the number entry.



### 5.1.2 Plus/minus weighing: Weighing-in

"Weighing-in" is suitable for filling to a preset target weight. For this, the function key must be assigned in the master mode to the WEIGHIN application under PLUSMIN.

#### Entering target/tolerance values

##### Notes

- Tolerances must be entered as a difference to the target value.  
Example: Target value = 10.000 kg, tol (+) = 0.100 kg, tol (-) = 0.050 kg.
- For tolerances taken over from a reference weight, the difference to the target value is calculated internally.  
Example: Target value = 10.000 kg, tol (+) = 10.100 kg, tol (-) = 9.050 kg.
- The following must always hold for the target value, the upper and lower tolerance (tol (+) and tol (-)) and the scale start value: target value < maximum load, target value + tol (+) ≤ maximum load, tol (-) < target value and scale start value < tol (-).

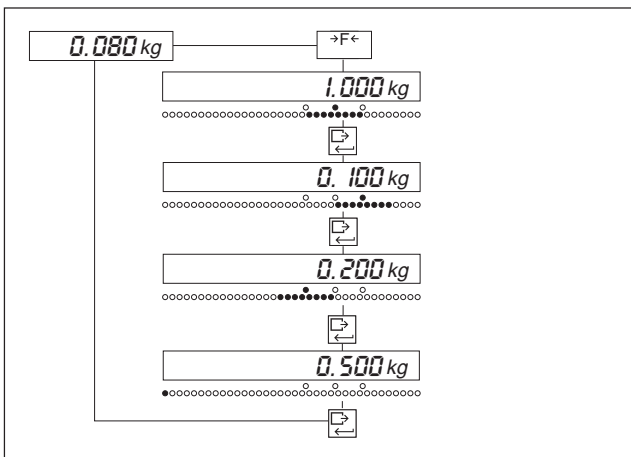

- Press the function key.
- When the target value marker flashes, enter target value or accept weighed value, confirm with the enter key.
- When the upper tolerance marker flashes, enter upper tolerance or accept weighed value, confirm with the enter key.
- Enter lower tolerance in an analogous manner.
- When the first red LED flashes, enter start value of the LED analog display or accept weighed value, confirm with the enter key.

#### Weighing-in

Depending on the selected setting, the digital display shows the actual weight, the difference to the target weight or the actual weight in % of the target weight.

- For weighing-in, add weighing sample.

Meaning of the LED analog display:

red LEDs	weight larger than start value, but below the tolerance
all green LEDs	weight within tolerance
2 green LEDs	target weight reached exactly
yellow LEDs	weight above tolerance

The 3 additional LEDs mark the lower tolerance, target value and upper tolerance.

### 5.1.3 Plus/minus weighing: Checking

"Checking" is suitable for testing whether the actual weight lies within preset tolerances. For this, the function key must be assigned in the master mode to the CHECK application under PLUSMIN.

#### Entering target/tolerance values

##### Notes

- Tolerances must be entered as a difference to the target value (example, see section 5.1.2).
- The following must always hold for the inputted values: target value < maximum load, target value + tol (+) ≤ maximum load, tol (-) < target value and zero limit < tol (-).
- Weighed tolerances are taken over as absolute values, the tolerance as a difference is calculated internally (example, see section 5.1.2).

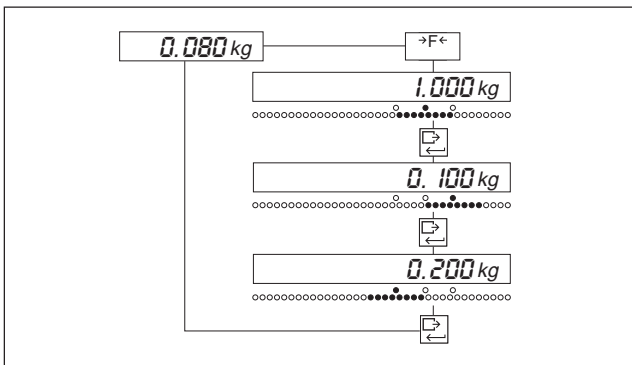

- Press the function key.
- When the target value marker flashes, enter target value or accept weighed value, confirm with the enter key.
- When the upper tolerance marker flashes, enter upper tolerance or accept weighed value, confirm with the enter key.
- Enter lower tolerance in an analogous manner.

#### Checking

Depending on the selected setting, the digital display shows the actual weight, the difference to the target weight or the actual weight in % of the target weight.

- For checking, add weighing sample.

Meaning of the LED analog display;

red LEDs	weight larger than start value, but below the tolerance
all green LEDs	weight within tolerance
2 green LEDs	target weight reached exactly
yellow LEDs	weight above tolerance

### 5.1.4 Plus/minus weighing: Classifying

"Classifying" is suitable for sorting the weighing sample into 3 weight classes. For this, the function key must be assigned in the master mode to the CLASS application under PLUSMIN.

The 3 weight classes are defined by the values zero limit, limit 1 and limit 2:

- Class 1: zero limit ≤ weight < limit 1
- Class 2: limit 1 ≤ weight < limit 2
- Class 3: limit 2 ≤ weight

#### Setting classes

##### Note

The following must hold for the inputted values: Zero limit < limit 1 < limit 2 < maximum load.

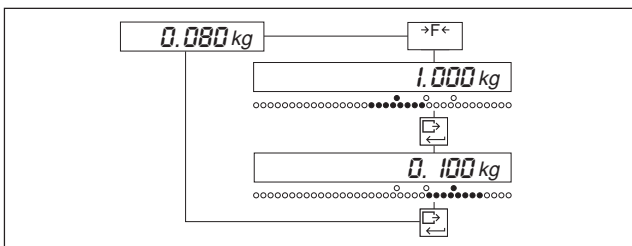

- Press the function key.
- When the lower tolerance marker flashes, enter limit 1 or accept weighed value, confirm with the enter key.
- Enter limit 2 at upper tolerance marker in an analogous manner.

#### Classifying

The digital display shows actual weight and class.

- Add weighing sample for classifying.

Meaning of the LED analog display:

- red LEDs Class 1
- green LEDs Class 2
- yellow LEDs Class 3

## 5.2 Gross recall

#### Requirements

- Function key has been assigned to GROSS in the master mode,
- a tare value is stored.

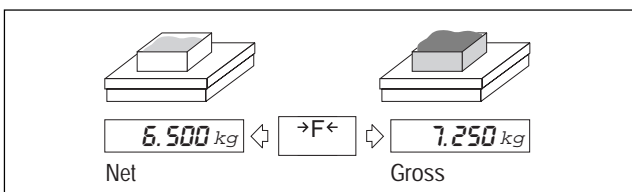

- Press and hold the function key. The gross weight is displayed. On release of the key, the net weight appears again.

### 5.3 Counting

#### Requirement

The function key has been assigned to COUNT in the master mode.

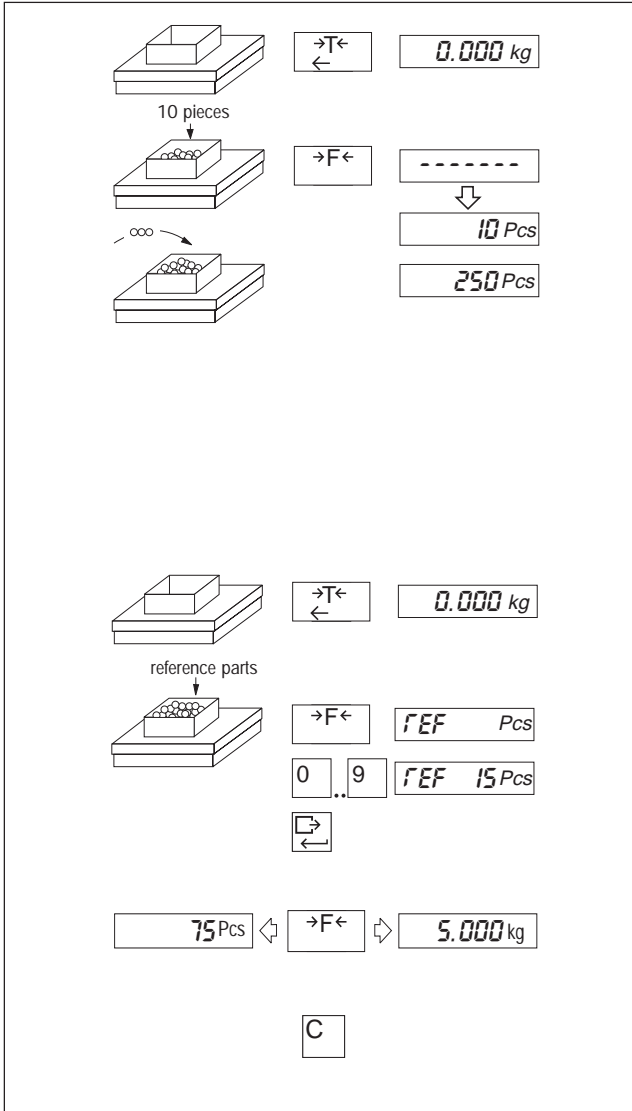

#### Counting-in (counting-out) with standard reference piece number (10 pieces)

- Tare empty (full) container.
- Add (remove) reference parts: Add (remove) 10 parts.
- Press the function key until the second beep.
- Add (remove) desired number.
  - In counting-out, the piece number is shown with a negative sign.

If ADD appears in the display after the function key has been pressed:

Either

- for improved weighing accuracy, increase reference parts by the displayed number and press the function key again.

Or

- press the function key again directly.

#### Counting with variable reference piece number

1-999 pieces can be set as a reference piece number (default setting is 10 pieces).

- Tare empty container.
- Add desired number of reference parts.
- Press and hold function key until REF appears in the display.
- Enter reference piece number and confirm with the enter key.

#### Switching piece number/weight

- Press the function key briefly.

#### Aborting counting

- Press and hold the clear key.
  - The piece number is cleared.

## 5.4 Formula weighing

### Requirement

The function key must be assigned to FORMUL in the master mode.

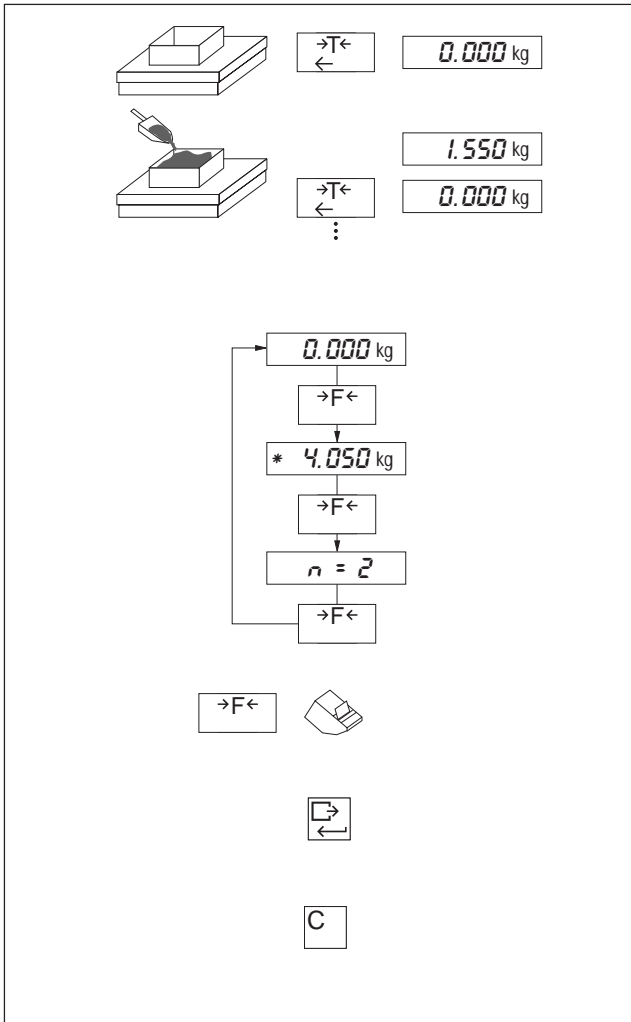

### Formula weighing

- Tare empty container.
- Add first component.
- Press the function key briefly.  
The weight is stored. If the component weight is too low, NO appears in the display.
- Add second component, press the function key briefly, etc.

### Displaying total weight and number

The function key can be used to switch the display between:

- the normal display
  - the display of the total weight (preceded by: "\*")
  - the display of the number (preceded by: "n = "; max. "n = 9999")
- Press and hold the function key until the 2nd beep. Repeat until the desired display appears.

### Printing total weight and number

- Press and hold the function key until the 3rd beep.

### Storing total weight and number temporarily

- Press the enter key.

### Aborting formula weighing = clearing total weight and number

- Press and hold the clear key.

## 5.5 Totalization

### Requirement

The function key must be assigned to TOTAL in the master mode.

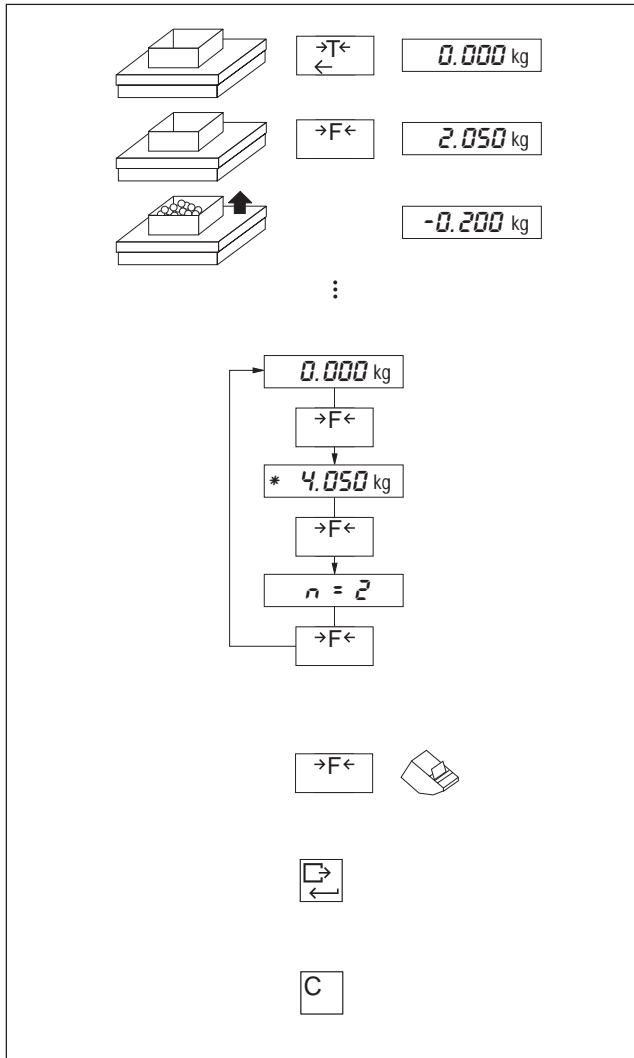

### Totalization

- Tare container.  
Before every weighing with a container having a different tare weight, retare.
- Load first item and press the function key briefly.
- Unload weighing platform.
- Load second item and press the function key briefly, etc.  
If an attempt is made to total the same item again, NO appears in the display.

### Displaying total weight and number

The function key can be used to switch the display between:

- the normal display
- the display of the total weight (preceded by: "\*")
- the display of the number (preceded by: "n = "; max. "n = 9999")
- Press and hold the function key until the 2nd beep. Repeat until the desired display appears.

### Printing total weight and number

- Press and hold the function key until the 3rd beep.

### Storing total weight and number temporarily

- Press the enter key.

### Aborting totalization = clearing total weight and number

- Press and hold the clear key.

## 5.6 Unit switching

When the scale is switched on, the 1st weight unit always appears.  
Weight values in the 2nd unit are shown with the symbol  $\Delta$ .  
Possible units are kg, g, lb, oz, ozt, dwt.

### Requirements

- The function key is assigned to UNIT in the master mode.
- Several weight units may be admissible, depending on the certification regulations of your country.

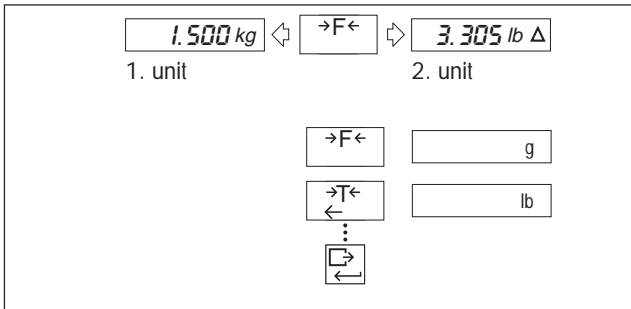

### Switching unit

- Press the function key briefly.

### Selecting the 2nd unit

- Press and hold the function key until the 2nd beep. The display switches to "2. UNIT".
- Press the tare key repeatedly until the display shows the desired second unit and confirm with the enter key.

## 5.7 Dynamic weighing

In dynamic weighing the weight is shown with the \* symbol.

As long as a dynamic result is displayed, only the clear and the function keys are active. The determined results are automatically totalized.

### Requirement

The function key is assigned to DYNAMIC in the master mode.

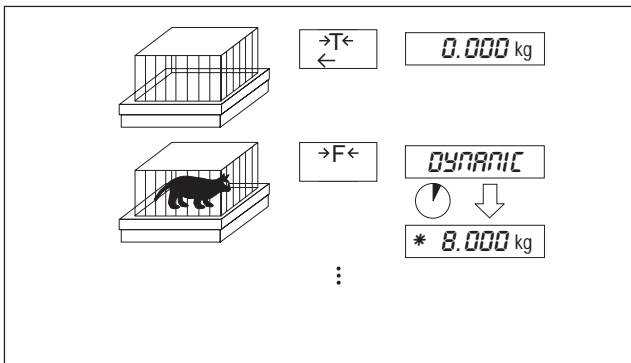

### Dynamic weighing

- Tare empty container.
- Place unstable weighing sample in container and press the function key briefly.
- Read off result.
- Place next weighing sample in the container and press the function key, etc.

On start of the next weighing cycle with a new container:

- Clear the display with the clear key.
- Retare.

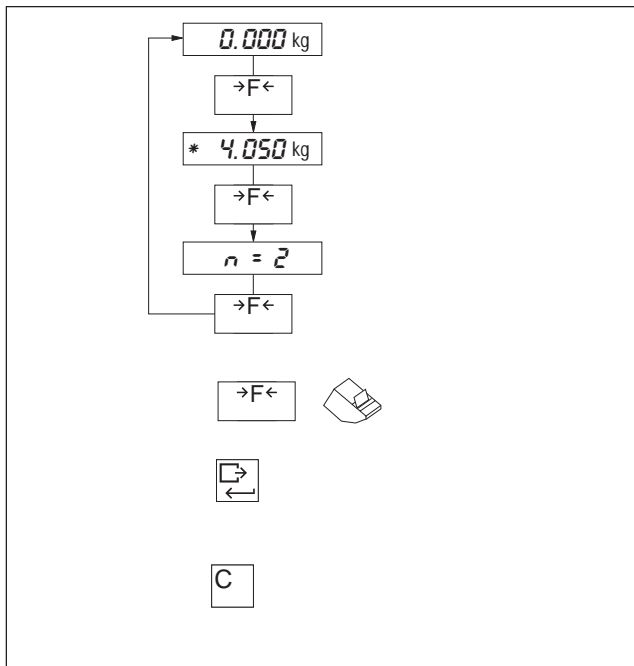

### Displaying total weight and number

The function key can be used to switch the display between:

- the normal display
- the display of the total weight (preceded by: "\*")
- the display of the number (preceded by: "n = "; max. "n = 9999")

- Press and hold the function key until the 2nd beep. Repeat until the desired display appears.

### Printing total weight and number

- Press and hold the function key until the 3rd beep.

### Storing total weight and number temporarily

- Press the enter key.

### Aborting dynamic weighing = clearing total weight and number

- Press and hold the clear key.

## 5.8 Display with enhanced readability

The weight display can be switched to enhanced readability with the function key.

### Requirement

The function key must be assigned to CONTROL in the master mode.

### Note

With enhanced readability, no weight unit is displayed.



## 6 Master mode

### 6.1 General information

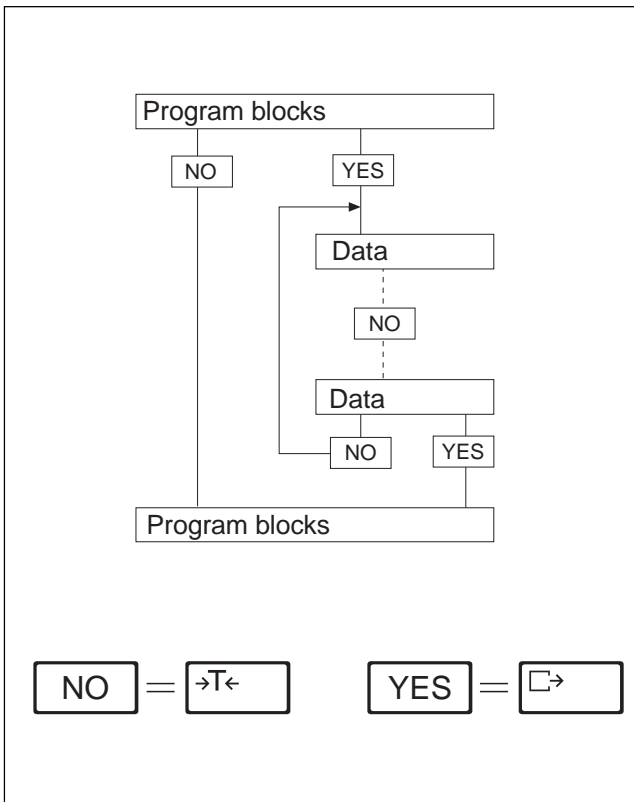

The scale is provided with a general purpose configuration in the factory, i.e. the selected parameters are those most frequently used (default configuration).

If the default configuration does not suit your requirements, you have the possibility to match the scale to your individual application conditions and end uses.

Parameters are modified in the master mode, a master program in which you are offered a selection of different sets of data.

The master mode is divided into successive program blocks with each block allowing the change of one or more parameters.

Regard the program blocks of data shown in the display quite simply as options which you respond to with YES or NO.

Use the keys shown opposite for your replies; they are allocated the meaning YES and NO in the master mode.

With NO you skip the displayed blocks or data. At the end of a data series, you return to the first value displayed.

With YES you select the data shown or enter the displayed program blocks.

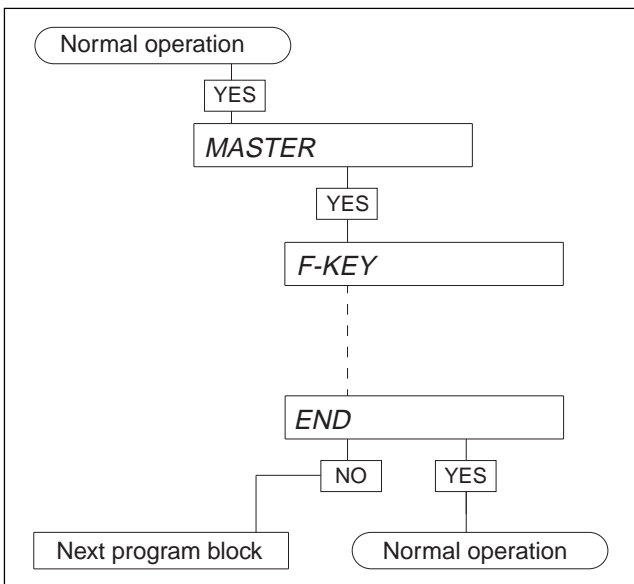

#### Entering the master mode

Press and hold the **C->** key until MASTER appears in the display.

Press the **C->** key again: The first program block F-KEY appears in the display.

#### Exiting the master mode

It is always possible to quit the master mode with YES when END appears in the display.

This is the case:

- after skipping the last program block;
- after selection of a value within a program block.

## 6.2 Overview of the master mode blocks

<b>F-KEY</b>	Assignment of the function key (6.2.1) The function key can be assigned one of the following functions: Plus-minus weighing, gross recall, piece counting, formula weighing, totalization, unit switching, dynamic weighing and control mode.
<b>LED</b>	Selecting type of analog display (6.2.2)
<b>LANGUAG</b>	Selecting the dialog language (6.2.3)
<b>DATE</b>	Entry of date and time and specification of the notation (6.2.4)
<b>PRINTER</b>	Configuring the printer (6.2.5 and operating instructions of the printer) This block appears only if a serial interface is fitted.
<b>I-FACE</b>	Configuring the interfaces (see interface description) This block appears only if a serial interface is fitted.
<b>RESET</b>	Resetting to default setting (6.2.6)
<b>PROCESS</b>	Matching the scale to the weighing sample (6.2.7)
<b>VIBRAT</b>	Matching the scale to the local conditions (6.2.8)
<b>STABLE</b>	Matching the stability detector (6.2.9)
<b>UPDATE</b>	Selecting the display speed (6.2.10)
<b>AUTZERO</b>	On/off switching of the autozero function (6.2.11)
<b>RESTART</b>	On/off switching of the restart function (6.2.12)
<b>PWROFF</b>	On/off switching of the automatic shutdown (6.2.13)
<b>INFO</b>	Display of the program number (6.2.14)
<b>CONTROL</b>	Testing the scale (6.2.15)
<b>END</b>	Exiting the master mode (6.2.16)

**6.2.1 F-KEY – Assignment of the function key**

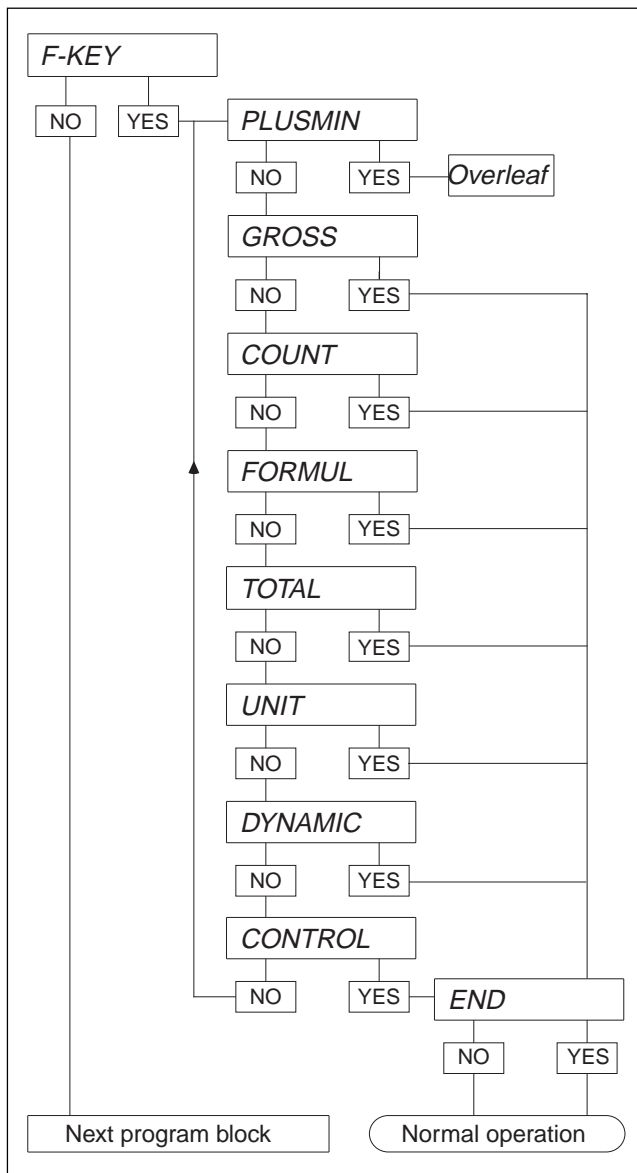

In this program block you can assign one of the following functions to the  $\rightarrow F \leftarrow$  key:

- PLUSMIN Plus/minus weighing
- GROSS Gross recall
- COUNT Piece counting
- FORMUL Formula weighing
- TOTAL Totalization
- UNIT Unit switching  
(with noncertified scales only)
- DYNAMIC Dynamic weighing
- CONTROL Display with higher resolution

You can activate the functions gross recall, piece counting, formula weighing, totalization, unit switching or control mode with YES.  
 Setting options for the "plus/minus weighing" function, see next page.  
 Setting options for the "dynamic weighing" function, see page 28.



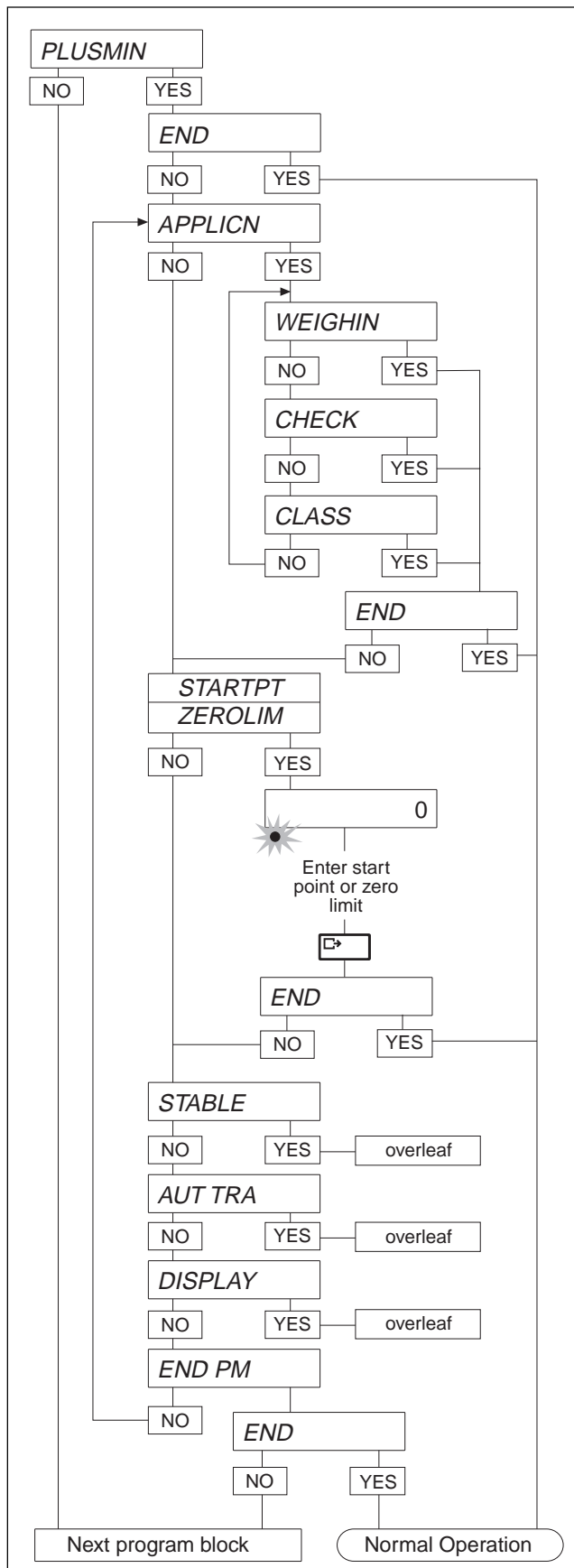

**PLUSMIN – Plus/minus weighing**

The following setting options are available with plus/minus weighing:

**APPLICN – Selection of the application**

**Note**

When the application is switched, the fixed value memories are automatically cleared!

WEIGHIN      Weighing in to a target weight.



CHECK        Checking whether the test specimen lies within the tolerance.

CLASS        Classification of the test specimens into weight classes.

**STARTPT**    Start point of the LED display in weighing-in. Entry in % of the lower tolerance limit.

**ZEROLIM**    Minimum weight in checking and classifying. The LED does not become active until the weight is equal to or greater than the zero limit.

Entering start point or zero limit:

-  Cursor one place to left.
-  Cursor one place to right.
-  Increment number by 1.

The lower LED flashes during the entry.

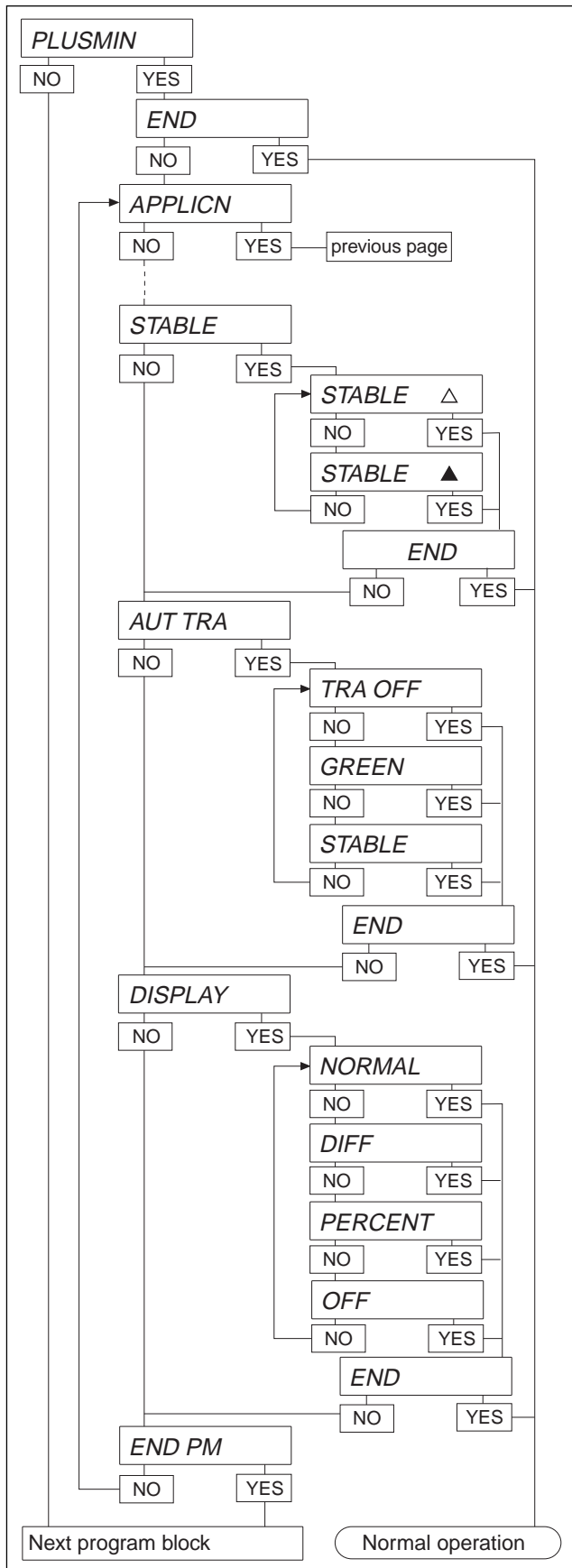

**STABLE – Stability-dependent LED display**

In the checking and classifying applications this is used to select whether the LED analog display should be on permanently or only when the scale is stable.

- STABLE △ LED display permanently on
- STABLE ▲ LED display only on stability

**AUT TRA – Automatic transfer**

If a serial data interface is installed, an automatic transfer of weight values can be switched on in the checking and classifying applications.

- TRA OFF Switches off the automatic transfer of weight values in plus/minus weighing.
- GREEN Stable weight values that lie within the plus/minus tolerance are sent.
- STABLE Every stable weight value is sent.

**DISPLAY – Digital display**

- NORMAL Normal weight display.
- DIFF Display of the difference between target and actual value. The display shows the symbol △. This option does not appear in classifying.
- PERCENT Display of the weight value in percent of the target value. This option does not appear in classifying.
- OFF Digital display switched off, weight status display and LED analog display are active.

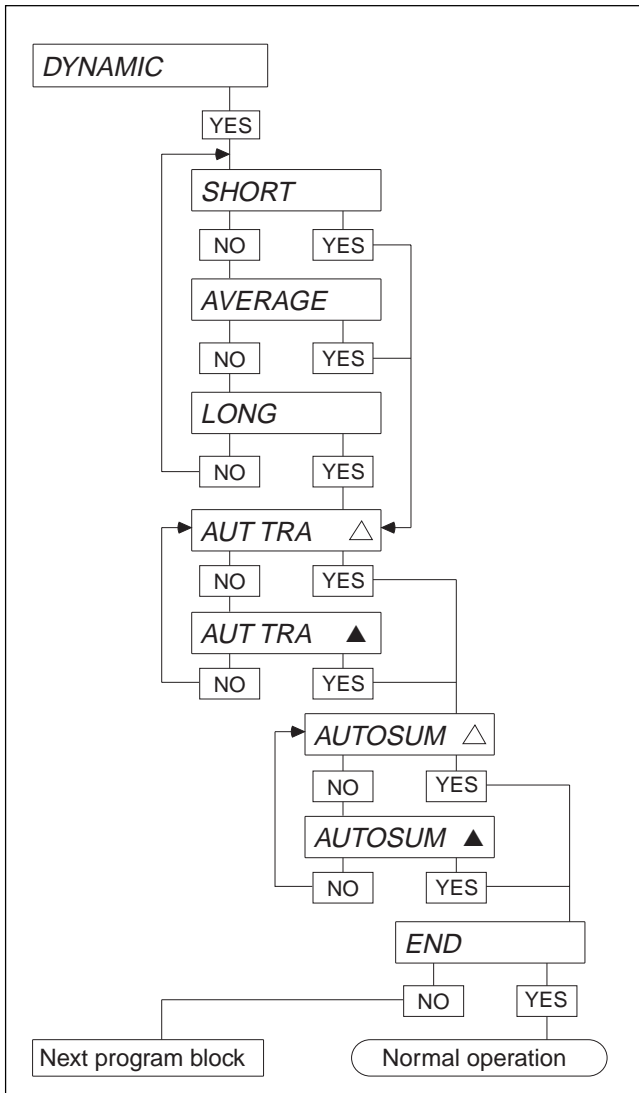

**DYNAMIC – Dynamic weighing**

Here you can set the measurement time for calculation of an average weight value: short (default), average or long. In addition you can determine whether data should be transferred automatically via the interface (AUT TRA) following the weighing.

Dynamic weighing offers the possibility of automatically totalizing the weight values (AUTOSUM); if a printer is attached the total can be printed out.

If the function AUT TRA or AUTOSUM is switched on, this is shown by the symbol ▲; if switched off (default) △ appears.

The weighing cycle can be started in two different ways:

- by pressing the  key.
- via the data interface by writing to application block 016 (see section 8).



**6.2.2 LED – Selecting the type of analog display**

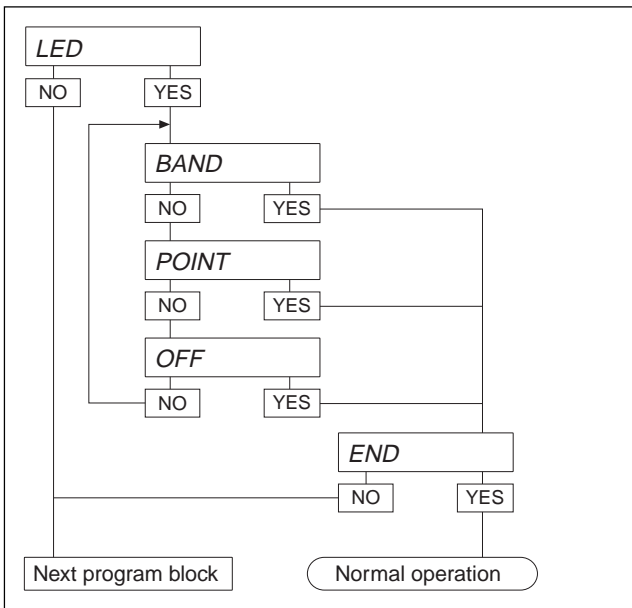

The selection applies to all operating modes except checking and classifying.

- BAND LED analog display in the form of an illuminated band.
- POINT LED analog display in the form of an illuminated point.
- OFF LED analog display switched off.

**6.2.3 LANGUAG – Selecting the dialog language**

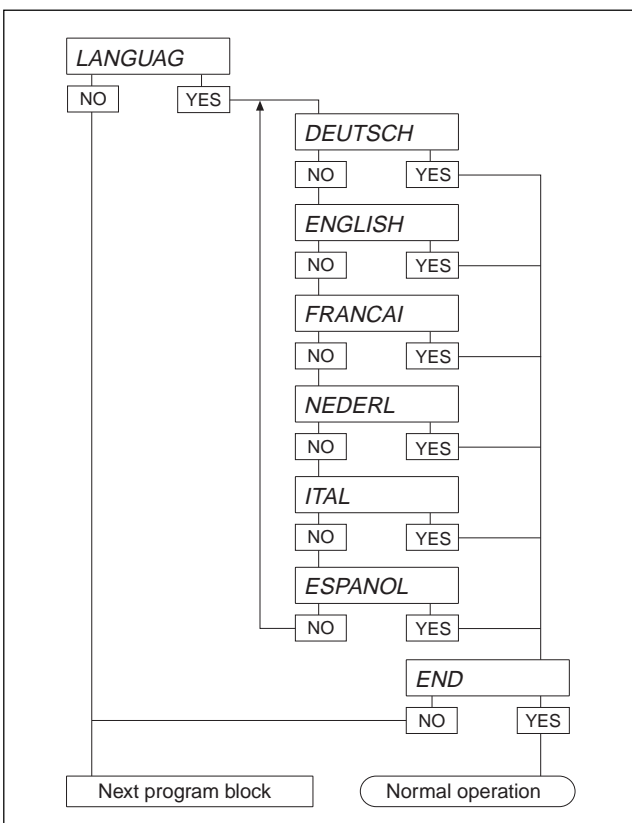

You can select the following dialog languages in the program block LANGUAG:

- DEUTSCH German
- ENGLISH English
- FRANCAI French
- NEDERL Dutch
- ITAL Italian
- ESPANOL Spanish

NO =

YES =

### 6.2.4 DATE – Entry of date and time

The weighing terminal is equipped with an internal clock with a calendar function which continues to operate when the terminal is switched off. Date and time can be printed out and outputted via the interface. Date and time can be shown in two different ways.

<b>E – Europe</b> (default)	Date:	Day Month Year
	Time:	(24) h min. sec.
<b>U – USA</b>	Date:	Month Day Year
	Time:	(12) h min. sec. AM/PM

Entry	Printout
e.g. 25.04.95	25/04/95
e.g. 14.28.55	14:28:55
e.g. 04.25.95	04/25/95
e.g. 02.28.55 PM	PM 02:28:55

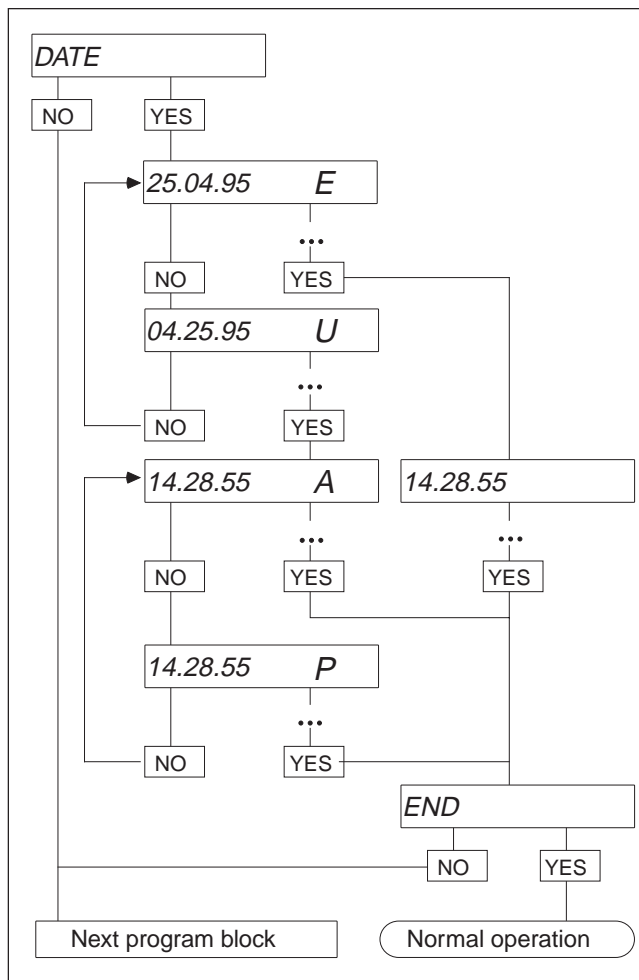

- Select type of date and time representation.
- Enter date and time (if need be with leading zeros). Use the decimal point as separator between day, month and year or hours, minutes and seconds.
- On entry of the date, the NO key serves to switch between European (E) and USA format (U).
- On entry of the US time, the NO key serves to switch between AM and PM.





**6.2.5 PRINTER – Configuring the printer**

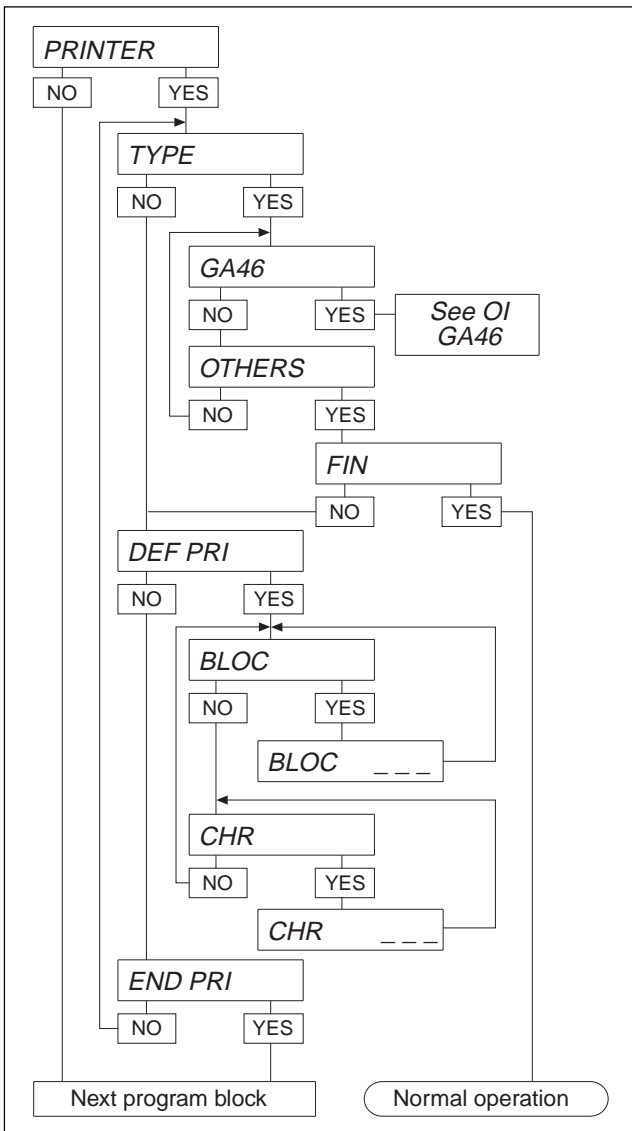

This block appears only if a serial interface is installed. In the program block you select the printer and configure the printout.

**TYPE – Selection of the printer**

**GA46** With this selection the correct transmission parameters for the GA46/GA46-W printer are set automatically. If need be the contrast and resistance value must be set, see operating instructions of GA46/GA46-W.

**OTHERS** Setting for printers other than GA46/GA46-W. With this setting the transmission parameters must be set in the INTERFACE block.

**DEF PRI – Configuring the printout**

**BLOC** Entry of the number of the application block to be printed out.

**CHR** Entry of the code of the characters to be printed out, see printer description.

**Closing configuration**

Enter BLOCK No. "00" and confirm with  to move to the program block "END PRI".

=

=

**6.2.6 RESET – Resetting to default setting**

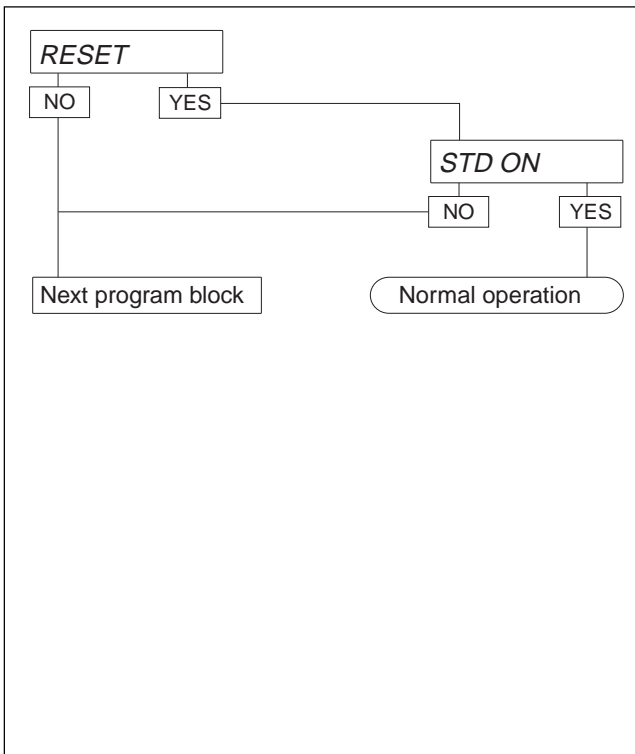

The program block RESET allows you to reset any parameters changed in the master mode to the default or standard factory settings at a keystroke. For the default settings, acknowledge STD ON with YES.

**Default setting**

- F-KEY      Gross recall; in the piece counting application, standard reference piece number 10 pieces; in the dynamic weighing application, measurement time short, AUT TRA off and AUTOSUM off
- PRINTER    Standard printout
- I-FACE     see interface description
- PROCESS    universal
- VIBRAT     normal
- STABLE     2
- AUTZERO    on
- AUTTARA    off
- RESTART    off

**Default settings for designations**

- Code key A    Article
- Code key B    Order

**6.2.7 PROCESS – Matching the scale to the weighing sample**

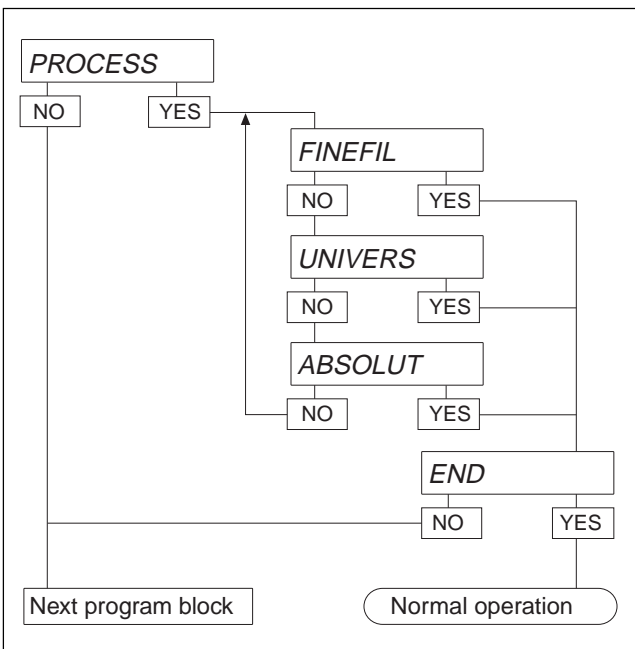

In this program block you can match the display of the weighing terminal to the weighing sample.

**Setting options**

- FINEFIL     liquid or powdery weighing sample
- UNIVERS    normal weighing sample
- ABSOLUT    solids



**6.2.8 VIBRAT – Matching the scale to the surroundings**

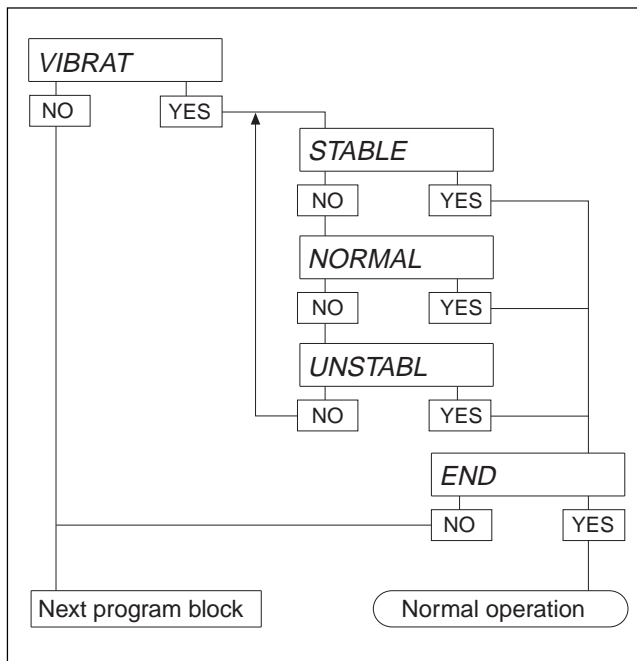

Depending on its location, the scale can be subjected to a lesser or greater extent to vibrations which are impossible to prevent. If this is the case, the program block VIBRAT offers the possibility to match the scale to the local vibrations.

**Setting options**

- STABLE** Weighing station free from vibrations and stable. The scale operates very rapidly, but is relatively sensitive to external disturbances (e.g. building oscillations, vibrations).
- NORMAL** Default setting for normal workstations.
- UNSTABL** Building oscillations and vibrations exist. The scale operates more slowly, but is less sensitive.

**6.2.9 STABLE – Matching the stability detector**

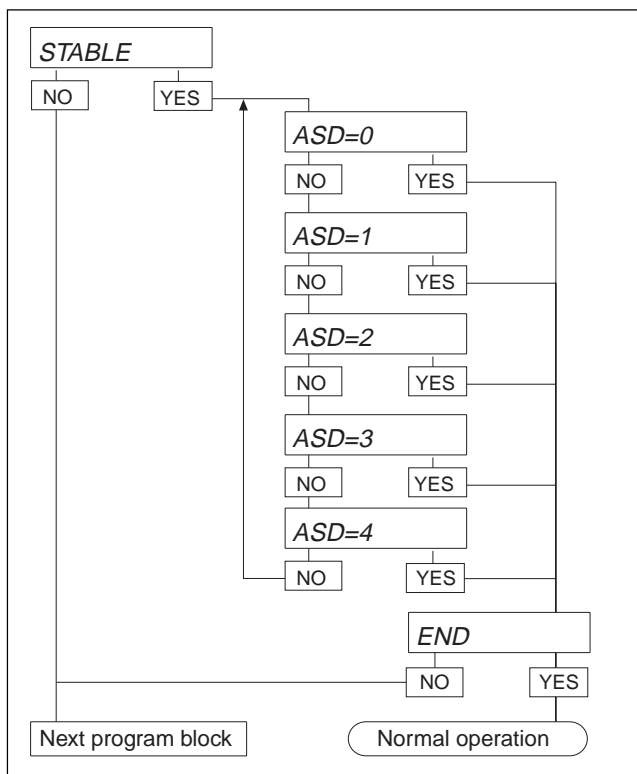

In this block you can match the automatic stability detector to meet your individual requirements. The settings change the time taken by the weighing platform to recognize stability.

Setting	Weighing speed	Reproducibility
ASD = 0	Stability detector switched off	
ASD = 1	rapid	good
ASD = 2 (default)	▲	▼
ASD = 3	▲	▼
ASD = 4	slow	very good

**Note**

ASD = 0 is selectable only with noncertified scales.

NO =  $\rightarrow T \leftarrow$

YES =  $\square \rightarrow$

**6.2.10 UPDATE – Selecting the display sped**

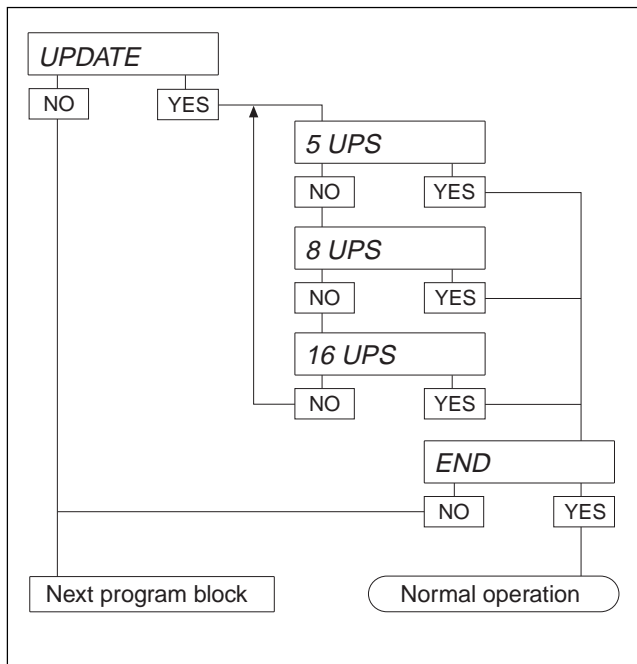

The display update speed can be set stepwise in terms of the number of measured values per second (updates per second, UPS).

The greater the number of UPSs selected, the higher the display update speed.

**6.2.11 AUTZERO – On/off switching of the autozero function**

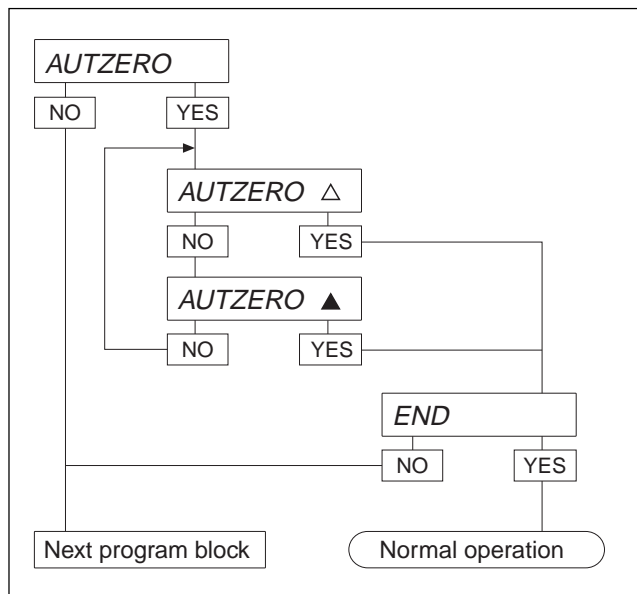

When the weighing platform is unloaded, the autozero function automatically compensates the weight of small amounts of dust or other contaminants. This block offers the possibility to switch the autozero correction on or off to suit your requirements.

**Note**

With certified scales, the autozero function is always switched on.

**Meaning of the symbols**

- ▲ AUTZERO on
- △ AUTZERO off



**6.2.12 RESTART – On/off switching of the restart function**

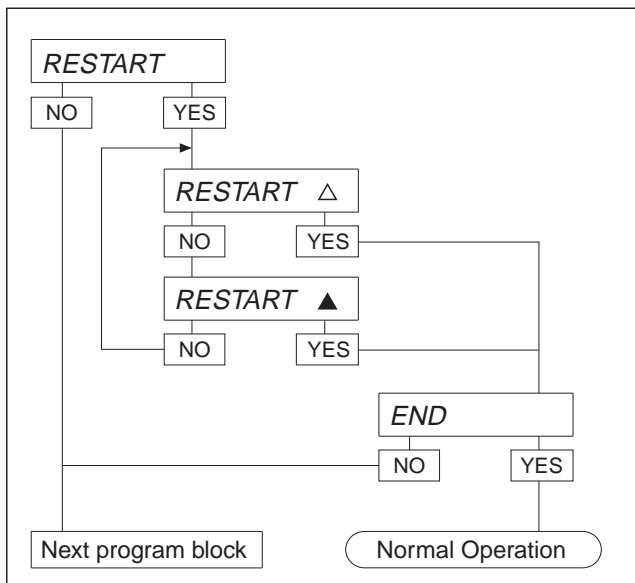

If the restart function has been activated, the zero point and tare value remain stored when the terminal is switched off. On switching on, in this case the scale shows the current weight and not zero.

The restart function is set to off in the factory.

The restart function can be activated only with a noncertified configuration. This program block is thus missing for certified scales.

With weighing platforms of the T and M series, the RESTART block is missing.

**Meaning of the symbols**

- △ RESTART off
- ▲ RESTART on

**6.2.13 PWROFF – On/off switching of the automatic shutdown**

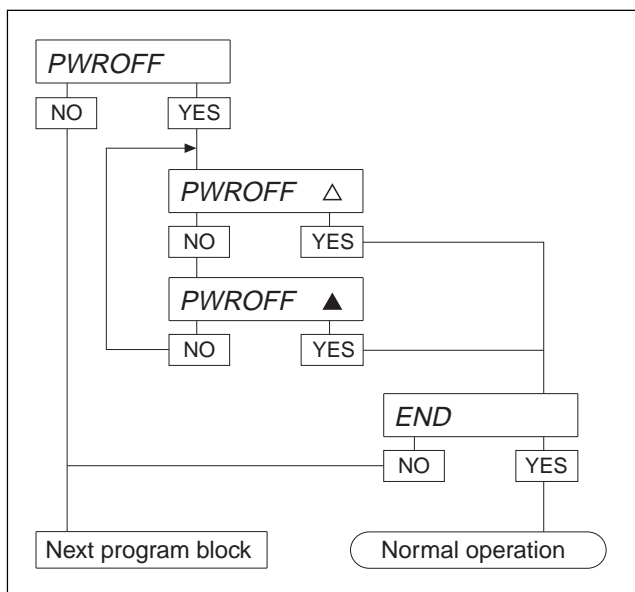

If the automatic shutdown is activated, the scale switches itself off automatically when no weight has been loaded for 10 minutes.

**Meaning of the symbols**

- △ PWROFF off
- ▲ PWROFF on



**6.2.14 INFO – Displaying the program number**

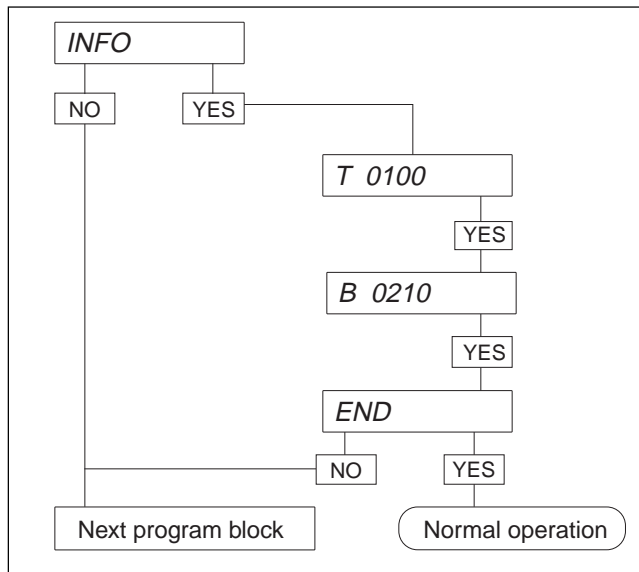

In the program block INFO you can have the instrument program numbers displayed (e.g., T 0100, B 0210).

**Identification**

T = weighing terminal number

B = weighing platform number

**6.2.15 CONTROL – Testing the scale**

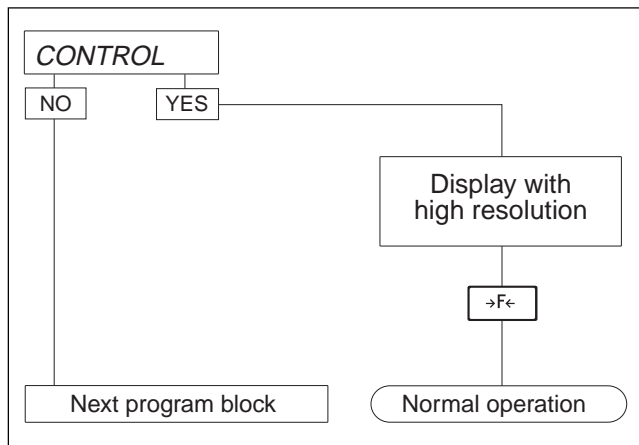

In the program block CONTROL, you can increase the resolution of the display for test purposes.

The program block does not appear with certified scales.

Your scale operates here with enhanced readability in the selected first weight unit.

Return to normal operation: Press .

**6.2.16 END – Exiting the Master mode**

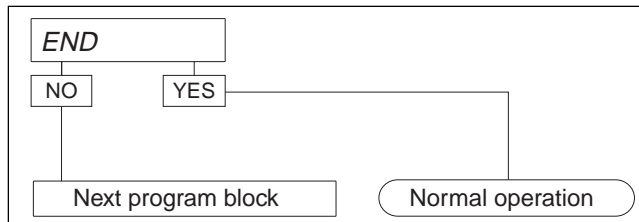

If you wish to change more data in the Master mode, return from END to the first program block with NO.

If not, press YES to return to normal operation.

=

=

## 7 Service mode

### 7.1 General

The service mode is used for

- entry of the parameters specific to the weighing platform,
- calibration of the scale,
- setting the linearity,
- resetting the measuring cell parameters to the factory setting.

The service mode is divided into program blocks within which one or more parameters can be changed.

#### Caution

The parameters which can be changed in the service mode are protected by certification. If the scale is set to certified (APPROVE in the program block SCALE), the identcode (identification code) counter will be incremented by one when the altered parameters are stored. In the case of a certified scale, this corresponds to destruction of the certification seal. Recertification of the scale is then necessary.

#### Overview of the service mode

RETURN	Quit service mode without changing the set parameters and the identcode counter.
RESET	Reset weighing platform parameters to factory setting, see section 7.3.1.
NATION	Selection of the country. This automatically takes the certification regulations of the particular country into account.
SCALE	Entry of the parameters specific to the weighing platform: certifiability, type, maximum capacity and resolution, see section 7.3.2.
LINEA	Enter or calibrate linearity, see section 7.3.3.
CAL	Calibration of the weighing platform, see section 7.3.4.
SAVE	Storage of the selected configuration, see section 7.3.5.

### 7.2 Operation of the service mode

Selection of the program blocks in the service mode is the same as in the Master mode.  
The numeric keypad is not available in the service mode!

#### 7.2.1 Entry into the service mode

- Press and hold the  key until MASTER appears in the display.
- Press NO to reach the SERVICE display.
- Press YES to enter the service mode. The inquiry CODE\_ appears.
- Enter code 2 4 8 16 32 and confirm with the  key. The first service mode block RETURN appears.

#### Caution

Entry of the code nullifies the certification validity of the scale!

### 7.2.2 Examples of numeric entries in the service mode

Only the two keys for YES and NO are active in the service mode, the numeric keypad is not available.

#### Example 1: Entry of the maximum capacity 60 kg

CA	150 kg
NO	
	0
NO	
	1
NO	
	⋮
	6
YES	
	60
YES	
	600
NO	
	60.
SI	
CA	60 kg

The maximum capacity shown in the display does not correspond to the desired value. Reply with NO.

The digit 0 appears. Use NO to increment the first digit to the desired value.

6 is the desired 1st digit, confirm with YES.

The digit 0 appears at the 2nd place. 60 is the desired value, confirm with YES.

A further place appears, but is not needed. Reply with NO.

60. is the desired value, confirm with YES.

For a check, the value of the maximum capacity just set now reappears. Confirm with YES and proceed to the next program block.

#### Example 2: Entry of the resolution 0.005 kg

d	0.001 kg
NO	
	0
YES	
	00
NO	
	0.
YES	
	0.0
YES	
	⋮
	0.000
NO	
	0.001
NO	
	⋮
	0.005
YES	
d	0.005 kg

The resolution shown in the display does not correspond to the desired value. Reply with NO.

The digit 0 appears, confirm with YES.

Another 0 appears before the point, but is not needed. Reply with NO.

The decimal point appears, confirm with YES.

Press YES for additional places until the number of desired decimal places is reached.

Select the desired resolution with NO.

0.005 is the desired value, confirm with YES.

For a check, the value of the resolution just set now reappears. Confirm with YES and proceed to the next program block.



## 7.3 Settings in the service mode

### 7.3.1 RESET – Resetting to the factory setting

The service mode block RESET contains the following subpoints:

NO RES	Quit the service mode block without resetting the parameters.
RES ALL	Reset parameters specific to weighing platform to the factory setting.

### 7.3.2 SCALE – Selecting the parameters specific to the weighing platform

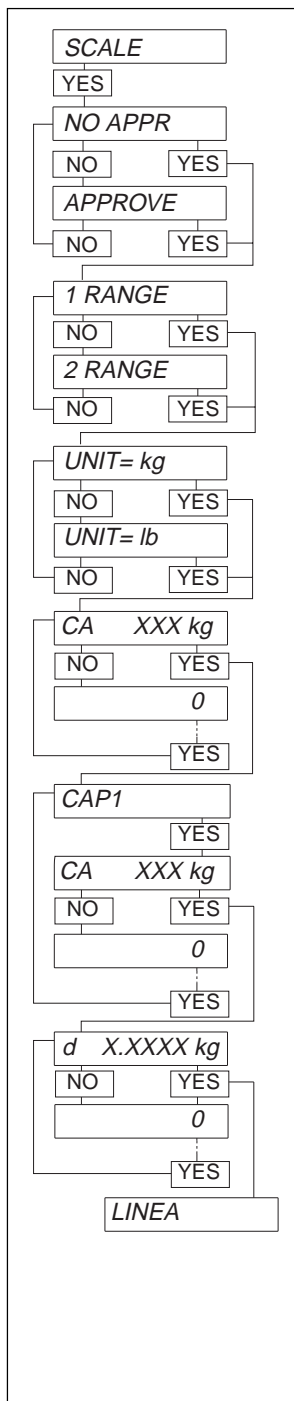

#### 1. Select certification capability

NO APPR	Noncertified scale
APPROVE	Certified scale

#### 2. Select number of weighing ranges

1 RANGE	Same resolution over the entire weighing range
2 RANGE	Two ranges with different resolution

#### 3. Select unit

UNIT = kg	Display in kg
UNIT = lb	Display in lb, if allowed by metrological regulations.

#### 4. Select maximum capacity

CA XXX kg	Maximum capacity currently set.
0	Enter desired maximum capacity and confirm, see section 7.2.2.

#### 5. Define weighing ranges (with multirange scales only)

CAP1	Display for information: Weighing range 1.
CA XXX kg	Value currently set for the first weighing range.
0	Enter desired value for the first weighing range, see section 7.2.2.

#### 6. Select resolution

d X.XXXX kg	Resolution currently set for the first weighing range. With multirange scales, the resolution of the second weighing range is automatically determined by the weighing terminal.
0	Enter desired resolution for the first weighing range, see section 7.2.2.

#### Note

If one of the settings or their combination was inadmissible, the message ERR\_Rx appears where x represents the weighing range. In this case, the program jumps back to step 1.

### 7.3.3 LINEA – Entering linearity

This service mode block can be used to compensate linearity errors. The linearity is usually checked with half the maximum capacity.

When half the maximum capacity is loaded on the scale in normal operation, the scale should show exactly this value. If this is not the case, note the displayed value (linearity) so that it can be entered at the appropriate place in the service mode.

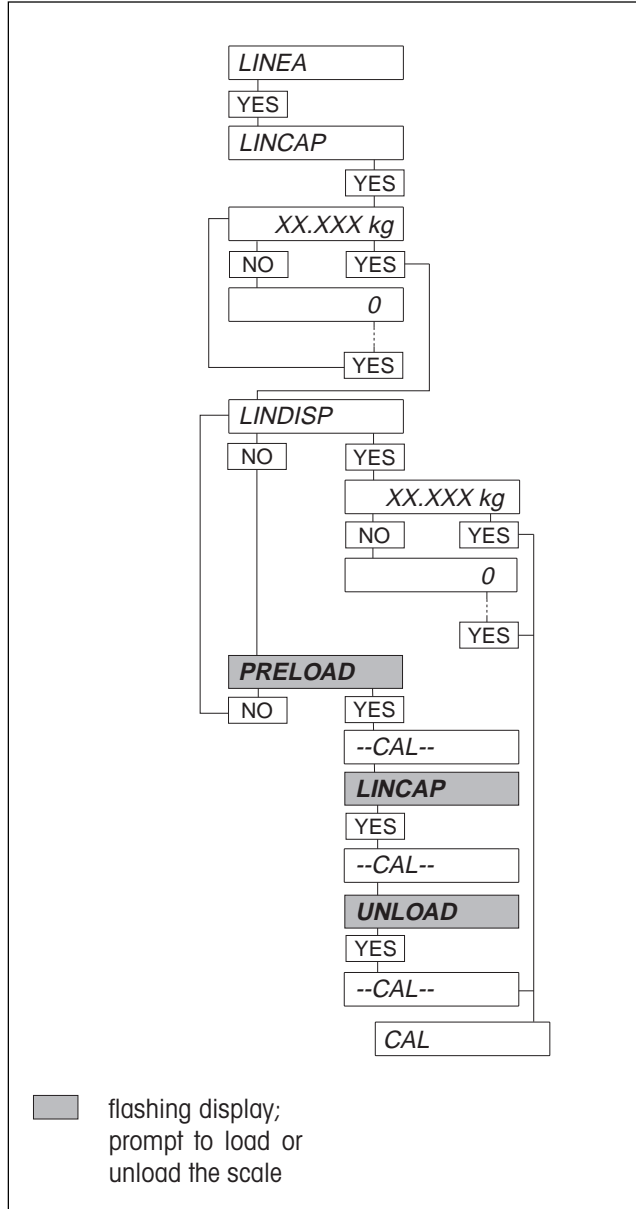

#### 1. Select linearization weight

LINCAP	Display for information: Linearization weight.
XX.XXX kg	Linearization weight currently set, e.g. half load.
0	Enter desired linearization weight, see section 7.2.2.

#### 2. Linearization

##### a) via entry of the linearity

LINDISP	Display for information: Linearity.
XX.XXX kg	Accept displayed weight value if it matches the weight value displayed when the linearization weight was loaded.
0	Enter weight value displayed when the linearization weight was loaded.

or

##### b) by loading the linearization weight

PRELOAD	Unload scale and load preload, if used, confirm with YES.
LINCAP	Load linearization weight selected in step 1, confirm with YES.
UNLOAD	Unload scale, confirm with YES.

**7.3.4 CAL – Calibrating weighing platform**

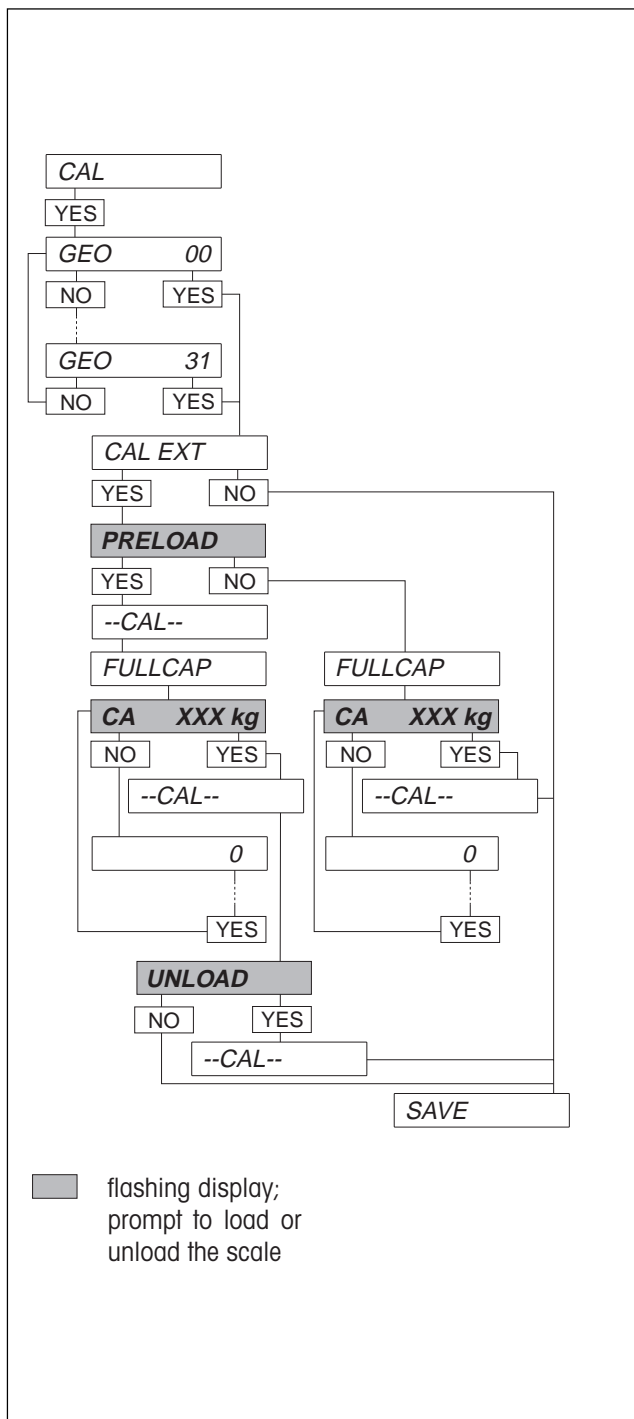

**1. Calibration using geo value**

If weighing platform and weighing terminal have already been matched to each other (calibrated) in the factory, the calibration can be corrected by the geo value up to a resolution of 3000 d.

If a higher resolution is required or if the weighing platform and weighing terminal have not yet been matched to each other, the calibration must be performed with external weights.

GEO 00            Select appropriate geo value. You will find the value appropriate to your country in the table in the appendix.

...  
GEO 31

**2. Calibration with an external weight**

CAL EXT            If you wish to calibrate with an external weight, confirm with YES.

PRELOAD            Load preload and confirm with YES. If you do not wish to calibrate the zero point, reply with NO (e.g. for the stepwise calibration of hopper scales).

--CAL--            The scale calibrates with preload if PRELOAD was confirmed with YES.

FULLCAP            Display for information: Maximum capacity.

CA XXX kg            Prompt to load and confirm the displayed maximum capacity.

**or**

0                    Enter desired maximum capacity.

--CAL--            The scale calibrates with maximum capacity.

UNLOAD            Unload weighing platform and confirm with YES.  
This prompt appears only if PRELOAD was answered with YES.

The calibration can be aborted at this point with NO, the program then jumps to the next service mode block SAVE.

--CAL--            The scale calibrates with preload.

### 7.3.5 SAVE – Storing the selected configuration

SAVE Storage of the selected configuration. The identcode counter is incremented by one. With certified scales, this corresponds to destruction of a certification seal. Recertification is then necessary.

#### Identcode counter at maximum

The identcode counter runs to 99. After this, additional certifiable configurations are not possible, the scale can be operated only in the noncertified configuration.

In this case, the following messages appear:

- Error                                   • Acknowledge error message.
- ident                                   – The error message then appears in clear text.

## 8 Application blocks

With the weighing terminal, an information memory is called an application block. The application blocks are used for the storage of

- character strings, which are entered using the keypad,
- weighing data,
- calculated quantities.

### Writing to and reading application blocks

If a serial interface is installed,

- the application blocks marked in the table overleaf can be written to via the data interface,
- all application blocks can be read via the data interface.

### Command formats for reading and writing via the data interface

**Reading**     A R   C<sub>R</sub> L<sub>F</sub>     Example:     A R 0 1 2 C<sub>R</sub> L<sub>F</sub>

The number of the application block is specified as a three-place number with leading zeros.

After receipt of the AR command: The weighing terminal sends the contents of the specified application block to the peripheral device.

Format of the transmitted application block: See table "Response formats in reading".

**Writing**     A W   \_ Information C<sub>R</sub> L<sub>F</sub>

See table "Command formats in writing"

Number of the application block to be written to

Format of the written application block: See table "Command formats in writing".

### Contents of the application blocks

No.	Contents	Comments
002	Current program number	
003	<STX>	} For printer configuration
004	<ETX>	
006	<CR><LF>	
007	Gross (2nd unit)	} Only in work with 2 weight units
008	Net (2nd unit)	
009	Tare (2nd unit)	
010	Weighing platform number	
011	Gross (1st unit)	
012	Net (1st unit)	
w 013	Tare (1st unit)	
014	Display contents	
w 016	Dynamic result (1st unit)	Writing to application block 016 starts the weighing cycle
017	Piece number	In counting
018	Difference	In plus/minus weighing
019	Percent	In plus/minus weighing (only with weighing-in and checking)

No.	Contents	Comments
w 020	Target value – upper tolerance – lower tolerance – start point	Current values In plus/minus weighing
w 021	Zero limit	In checking and classifying
022	Component/item weight	} In formula weighing and totalization
023	Total weight	
024	Component/item counter	
025	Tare container	In formula weighing
w 026	For each memory:	25 fixed value memories
...	target value – upper tolerance	
...	– lower tolerance – start point	
w 050		
w 051	Date and time	
w 052	Date	
w 053	Time	
w 054	Code key A: Designation and identification	
w 055	Code key B: Designation and identification	
w 056	Output buffer of the I/O port	} Only if interface 303 attached
057	Input buffer of the I/O port	

w = writable blocks

### Response formats in reading

No.	Response format																		
002	<table border="1"><tr><td>A</td><td>B</td><td>_</td><td>I</td><td>T</td><td>3</td><td>s</td><td>-</td><td>0</td><td>-</td><td>0</td><td>-</td><td>0</td><td>1</td><td>0</td><td>0</td><td>C<sub>R</sub></td><td>L<sub>F</sub></td></tr></table>	A	B	_	I	T	3	s	-	0	-	0	-	0	1	0	0	C <sub>R</sub>	L <sub>F</sub>
A	B	_	I	T	3	s	-	0	-	0	-	0	1	0	0	C <sub>R</sub>	L <sub>F</sub>		
007	} <table border="1"><tr><td>A</td><td>B</td><td>_</td><td>val.</td><td>_</td><td>unit</td><td>C<sub>R</sub></td><td>L<sub>F</sub></td></tr></table> val. = 10-digit value (with sign and decimal point), right aligned; unit = unit, 3 characters, left aligned	A	B	_	val.	_	unit	C <sub>R</sub>	L <sub>F</sub>										
A		B	_	val.	_	unit	C <sub>R</sub>	L <sub>F</sub>											
008																			
009																			
010	<table border="1"><tr><td>A</td><td>B</td><td>_</td><td>n2</td><td>C<sub>R</sub></td><td>L<sub>F</sub></td></tr></table> n2 = 2 places	A	B	_	n2	C <sub>R</sub>	L <sub>F</sub>												
A	B	_	n2	C <sub>R</sub>	L <sub>F</sub>														
011	} see 007																		
...																			
014 016																			
017	<table border="1"><tr><td>A</td><td>B</td><td>_</td><td>val.</td><td>_</td><td>unit</td><td>C<sub>R</sub></td><td>L<sub>F</sub></td></tr></table> val. = 10-digit value (with sign and decimal point), right aligned; unit = STK or PCS	A	B	_	val.	_	unit	C <sub>R</sub>	L <sub>F</sub>										
A	B	_	val.	_	unit	C <sub>R</sub>	L <sub>F</sub>												
018	} see 007																		
019																			

020 In weighing-in

A	B		val.	unit		val.	unit		val.	unit		val.	unit	C <sub>R</sub>	L <sub>F</sub>				
				target value					tol. (+)					tol. (-)					start point

In checking:

A	B		val.	unit		val.	unit		val.	unit	C <sub>R</sub>	L <sub>F</sub>		
				target value					tol. (+)					tol. (-)

In classifying

A	B		val.	unit		val.	unit	C <sub>R</sub>	L <sub>F</sub>		
					limit 1						limit 2

val. = 10-digit value (with sign and decimal point), right aligned;  
unit = STK or PCS

022 }  
023 } see 007

024 

A	B														number		C <sub>R</sub>	L <sub>F</sub>
---	---	--	--	--	--	--	--	--	--	--	--	--	--	--	--------	--	----------------	----------------

  
number = 3-digit, left aligned

025 see 007

026 }  
... } see 020  
050 }

051 European format: 

A	B																		
---	---	--	--	--	--	--	--	--	--	--	--	--	--	--	--	--	--	--	--

T	T	/	M	M	/	J	J								h	h	:	m	m	:	s	s	C <sub>R</sub>	L <sub>F</sub>
---	---	---	---	---	---	---	---	--	--	--	--	--	--	--	---	---	---	---	---	---	---	---	----------------	----------------

USA format: 

A	B																								
---	---	--	--	--	--	--	--	--	--	--	--	--	--	--	--	--	--	--	--	--	--	--	--	--	--

M	M	/	T	T	/	J	J								<sup>A</sup> P	M		h	h	:	m	m	:	s	s	C <sub>R</sub>	L <sub>F</sub>
---	---	---	---	---	---	---	---	--	--	--	--	--	--	--	----------------	---	--	---	---	---	---	---	---	---	---	----------------	----------------

052 European format: 

A	B														T	T	/	M	M	/	J	J	C <sub>R</sub>	L <sub>F</sub>
---	---	--	--	--	--	--	--	--	--	--	--	--	--	--	---	---	---	---	---	---	---	---	----------------	----------------

USA format: 

A	B														M	M	/	T	T	/	J	J	C <sub>R</sub>	L <sub>F</sub>
---	---	--	--	--	--	--	--	--	--	--	--	--	--	--	---	---	---	---	---	---	---	---	----------------	----------------

054 }  
055 } 

A	B		designation (18 characters)														identification (18 characters)												C <sub>R</sub>	L <sub>F</sub>
---	---	--	-----------------------------	--	--	--	--	--	--	--	--	--	--	--	--	--	--------------------------------	--	--	--	--	--	--	--	--	--	--	--	----------------	----------------

057 

A	B		0	0	0	0	x	x	C <sub>R</sub>	L <sub>F</sub>
---	---	--	---	---	---	---	---	---	----------------	----------------

x=0: no power supplied; x=1: power supplied

**Command formats in writing****No. Command format**

013 

A	W	0	1	3	_	val.	_	unit	C <sub>R</sub>	L <sub>F</sub>
---	---	---	---	---	---	------	---	------	----------------	----------------

  
val. = 10-digit value (with sign and decimal point), right aligned;  
unit = STK or PCS

016 

A	W	0	1	6	_	val.	C <sub>R</sub>	L <sub>F</sub>
---	---	---	---	---	---	------	----------------	----------------

  
val. = 7-digit value  
Writing to application block 016 starts the weighing cycle.

020 In weighing-in  

A	B	_	val.	_	unit	_	val.	_	unit	_	val.	_	unit	_	val.	_	unit	C <sub>R</sub>	L <sub>F</sub>
---	---	---	------	---	------	---	------	---	------	---	------	---	------	---	------	---	------	----------------	----------------

  
target value      tol. (+)      tol. (-)      start point

in checking:

A	B	_	val.	_	unit	_	val.	_	unit	C <sub>R</sub>	L <sub>F</sub>
			target value			tol. (+)			tol. (-)		

In classifying:

A	B	_	val.	_	unit	_	val.	_	unit	C <sub>R</sub>	L <sub>F</sub>
			limit 1			limit 2					

val. = 10-digit value (with sign and decimal point), right aligned;  
unit = STK or PCS

021 see 013

026 }  
... } see 020  
050 }

051 Date and time  
European format: 

A	W	0	5	1	_	T	T	/	M	M	/	J	J	H <sub>T</sub>
---	---	---	---	---	---	---	---	---	---	---	---	---	---	----------------

h	h	:	m	m	:	s	s	C <sub>R</sub>	L <sub>F</sub>
---	---	---	---	---	---	---	---	----------------	----------------

USA format: 

A	W	0	5	1	_	M	M	/	T	T	/	J	J	H <sub>T</sub>
---	---	---	---	---	---	---	---	---	---	---	---	---	---	----------------

A	M	_	h	h	:	m	m	:	s	s	C <sub>R</sub>	L <sub>F</sub>
---	---	---	---	---	---	---	---	---	---	---	----------------	----------------

The following holds for both formats:

With date: . is possible in place of /.

With time: / or . is possible in place of :.

052 Date: 

A	W	0	5	2	_	T	T	/	M	M	/	J	J	C <sub>R</sub>	L <sub>F</sub>
---	---	---	---	---	---	---	---	---	---	---	---	---	---	----------------	----------------

053 Time: 

A	W	0	5	3	_	h	h	:	m	m	:	s	s	C <sub>R</sub>	L <sub>F</sub>
---	---	---	---	---	---	---	---	---	---	---	---	---	---	----------------	----------------

054 

A	W	0	5	4	_	design	(max. 18 characters)	H <sub>T</sub>	ident	(18 characters)	C <sub>R</sub>	L <sub>F</sub>
---	---	---	---	---	---	--------	----------------------	----------------	-------	-----------------	----------------	----------------

  
Code A: The command replaces the existing designation.

055 see 054: here for code B instead of code A

056 





A	W	0	5	6	_	0	0	0	0	0	0	x	x	x	C <sub>R</sub>	L <sub>F</sub>
---	---	---	---	---	---	---	---	---	---	---	---	---	---	---	----------------	----------------

  
x=0: no power supplied; x=1: power supplied

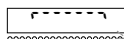
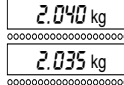

## 9 Appendix

### 9.1 What if...?

Display	Cause	Rectification
 Display blank	<ul style="list-style-type: none"> <li>No line voltage</li> <li>Terminal switched off</li> <li>Power cable not plugged in</li> <li>Brief disturbance</li> <li>Automatic shutdown active</li> <li>Display switched off in master mode</li> </ul>	<ul style="list-style-type: none"> <li>Check power supply</li> <li>Switch on</li> <li>Plug in</li> <li>Switch terminal off then on</li> <li>Press any key</li> </ul>
	Underload owing to <ul style="list-style-type: none"> <li>Load plate not in place</li> <li>Preload not loaded</li> <li>Weighing range not reached</li> </ul>	<ul style="list-style-type: none"> <li>Place load plate in position</li> <li>Load preload</li> <li>Zero</li> </ul>
	Overload owing to <ul style="list-style-type: none"> <li>Weighing range exceeded</li> <li>Weighing platform locked in place</li> </ul>	<ul style="list-style-type: none"> <li>Unload weighing platform</li> <li>Release arrestment</li> </ul>
 Display unstable	<ul style="list-style-type: none"> <li>Unstable location</li> <li>Drafts</li> <li>Unstable weighing sample</li> <li>Contact between load plate or weighing sample and surroundings</li> <li>Line disturbance</li> </ul>	<ul style="list-style-type: none"> <li>Match vibration adapter (master mode VIBRAT)</li> <li>Avoid drafts</li> <li>Use dynamic weighing operating mode</li> <li>Eliminate contact</li> <li>Check power supply</li> </ul>
Wrong display	<ul style="list-style-type: none"> <li>Wrong zero setting of scale</li> <li>Wrong tare value</li> <li>Contact between load plate or weighing sample and surroundings</li> <li>Scale at inclined angle</li> </ul>	<ul style="list-style-type: none"> <li>Unload, zero and repeat weighing</li> <li>Clear tare or enter correct tare</li> <li>Eliminate contact</li> <li>Level scale</li> </ul>
	<ul style="list-style-type: none"> <li>Test cycle started</li> </ul>	<ul style="list-style-type: none"> <li>Conclude test by pressing the test key</li> </ul>
	<ul style="list-style-type: none"> <li>Zero setting outside zero setting range</li> <li>Taring outside taring range</li> <li>Zero setting with underload/overload</li> <li>Recalled fixed target value memory not occupied in plus/minus weighing</li> <li>Reference weight too low in counting</li> <li>Weight less than 10 d in totalization</li> <li>Item counter &gt; 9999</li> <li>Deflection &lt; 30 d in formula weighing</li> <li>Component negative in formula weighing</li> </ul>	<ul style="list-style-type: none"> <li>Load fixed target value memory</li> <li>Increase reference piece number</li> <li>Increase weight</li> <li>Clear total</li> <li>Load weight</li> <li>Increase component weight</li> </ul>
No LED display	<ul style="list-style-type: none"> <li>LED analog display switched off</li> </ul>	<ul style="list-style-type: none"> <li>Switch on LED analog display (master mode LED)</li> </ul>
Red LEDs do not light up in checking and classifying	<ul style="list-style-type: none"> <li>Zero limit set larger than lower tolerance limit</li> </ul>	<ul style="list-style-type: none"> <li>Set zero limit to lower value (master mode)</li> </ul>

## 9.2 Cleaning

- ▲ Clean only outside of weighing terminal.
- ▲ Never use concentrated acids and alkalis, solvents or pure alcohol!
- Use a damp sponge for cleaning.  
Grease spots and obstinate dirt marks can be removed with commercial washing-up liquid or glass cleaning agents. The best agents are antistatic plastic cleaners and plastic preserving agents.

## 9.3 Technical data

### Main data

Digital display for weight	High-intensity, 7-segment fluorescent display, green with integrated unit characters and status symbols for display of the operating mode, digit height 12.5 mm.
Analog display	High-intensity, 3-color LED line. For weighing-in, checking and classifying. Dynamic display as light band or light spot, static display as 3-color illuminated field.
Keypad	Tactile touch membrane keypad with audio acknowledgment. Symbol inscription. 4 keys for weighing operation, 2 keys for identification data, numeric keypad for the entry of numeric data, with enter and clear keys, important keys enlarged.
Display window	Scratch-proof safety glass or plastic.

### Weighing functions

Taring	At a keystroke or automatic, by subtraction up to maximum capacity (by subtraction).
Preset tare	With single range scales over the entire weighing range (by subtraction). With multiple range scales, dependent on national certification regulations.
Zero set	Automatic or manual.
Gross select	Display of gross weight at a keystroke.
Unit select	Following weight units selectable at a keystroke: kg, g, lb, oz, ozt, dwf.
Dynamic weighing	Selectable: Cycle time (3 settings) and automatic printout, data transfer and automatic totalization.
Stability detector	4 settings, with movement indicator.
Weighing process adapter	3 settings available to match the scale to the weighing sample.
Vibration adapter	3 settings available to match the scale to the ambient conditions.
Test	Test function to display the identification code.

### Plus/minus weighing

Weighing in	Filling to a preset target weight.
Checking	Check whether test object is within preset tolerance.
Classifying	Sorting into 3 classes.

### Counting functions

Piece number	Continuously updated display, max. 7 places.
Reference weight determination	Either from standard reference piece number (simple one-key operation) or from variable reference piece number (1-999 pieces).
Minimum reference monitoring	Dependent on attached weighing platform.
Start of the counting process	At a keystroke with the possibility to switch to the current weight.

**Formula weighing**

Number of components	Maximum 9999 components.
Component total	7 places.

**Totalization**

Number of items	Maximum 9999 items.
Item total	7 places.
Dynamic result	Automatic totalization.

**General functions**

Identification data	2 keys A and B each with 18-place memory, fail-safe storage, for numeric data. Each memory can be assigned a fixed designation which is written in the inscription field next to the corresponding key.
Date and time	For printout or output via the data interface. Quartz crystal controlled, 12- or 24-hour display, automatic calendar function, European or USA format, fail-safe storage.

**Scale attachment**

Attachable weighing platforms	Strain gauge weighing platforms METTLER TOLEDO MultiRange with analog interface: types DB, DCC, D...T, N...T; strain gauge load mounts RWM; SPIDER weighing platforms
A/D converter	Resolution: certifiable max. 7500 e; noncertifiable max. 75000 d Strain gauge supply voltage: 8.75 V Limit value: 1.17 $\mu\text{V/e}$ Max. line length: 100 m Stabilization time: typically 0.6 s Measured value update: selectable in steps, max. 16/s
Third-party scales	1-4 350 $\Omega$ weighing cells; 1-8 1000 $\Omega$ weighing cells Platform sensitivity: 0.4...3 mV/V Platform resistance: 80...1200 $\Omega$

**General data**

Housing	All chrome-nickel steel DIN X5 CrNi 1810
Type of protection	Dust- and water-proof (spray water), in compliance with IP65 (IEC 529)
Power supply	115/230 V~; +10% - 15%; 50/60 Hz
Power cable	With grounding pin plug, length approx. 2.5 m
Power consumption	Approx. 25 VA
Admissible operating temperature	-10 °C to +40 °C
Weight	2.8 kg
Documentation supplied	Operating instructions

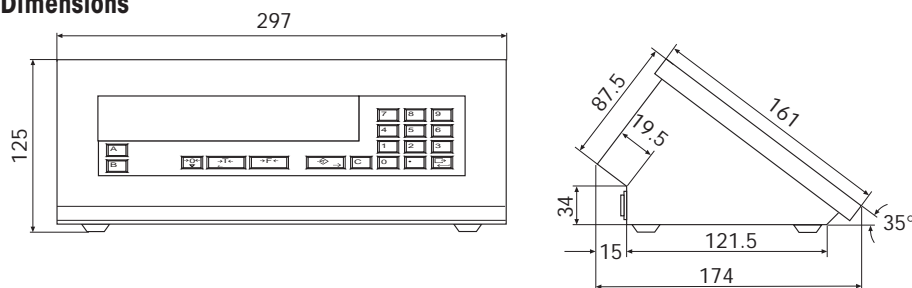
**Dimensions**

## 9.4 Optional equipment

	<b>Order no.</b>
<b>Strip printer (alphanumeric thermal printer)</b>	
GA46	505 471
GA46-W	505 799
Printer-terminal adapter for fastening the printer to the terminal	208 264
<b>Interface 301*</b>	
Retrofittable built-in interface for 20 mA current loop connection, bidirectional, 7-pin socket	506 134
<b>Accessories CL 20 mA</b>	
CL cable, 3 m	503 749
General purpose cable, 3 m	503 743
LX80/FX85 cable, 3 m	500 410
Mating connector, 7-pin	503 745
<b>Interface 302*</b>	
Retrofittable built-in interface for RS232C connection, bidirectional, 8-pin socket	506 135
<b>Accessories RS232</b>	
RS232 cable/DTE, 3 m	503 754
RS232 cable/PC, 3 m	504 374
RS232 cable/DCE, 3 m	503 755
RS232 cable/9-pin, 3 m	504 376
Mating connector, 8-pin	503 756
<b>Interface 303</b>	
Retrofittable built-in interface, digital inputs/outputs, 19-pin socket	505 714
<b>Accessories I/O</b>	
GD14 relay interface, for signal amplification	504 371
GD14 connection cable, 10 m	504 458
Mating connector, 19-pin	504 461
<b>Interface 304*</b>	
Retrofittable built-in interface for RS422/RS485 connection, bidirectional, 6-pin socket	506 964
<b>Accessories RS422/RS485</b>	
Cable with 6-pin connector and open end, 3 m	204 933
Mating connector, 6-pin	204 866
<b>Analog cable with both ends open</b>	
5 m	204 554
10 m	204 555
20 m	209 315
<b>Wall bracket</b> , for fastening the weighing terminal to the wall	
- black, plastic coated	504 129
- all stainless steel	504 130
<b>Floor stand</b> , for free standing weighing terminal	
- black, plastic coated	504 131
- all stainless steel	504 132
<b>Stand base</b> , for flexible installation of the floor stand	
- black, plastic coated	503 700
- all stainless steel	503 701
<b>Protective cover</b> , for covering the weighing terminal, set of 3	505 319

\* only 1 serial interface retrofittable

**9.5 Geo value table**

<b>Country</b>			<b>Geo value</b>	<b>Country</b>			<b>Geo value</b>
A	Austria		19	MA	Morocco		13
AUS	Australia		12	MAL	Malaysia		5
B	Belgium		21	MEX	Mexiko		5
BR	Brazil		8	N	Norway		24
CDN	Canada		18	NL	Netherlands		21
CH	Switzerland		18	NZ	New Zealand		16
CO	Columbia		2	P	Portugal		15
D	Germany		20	PE	Peru		6
DK	Denmark		23	PRC	China		10
E	Spain		15	RA	Argentina		13
EC	Ecuador		1	RCH	Chile		12
ET	Egypt		11	RI	Indonesia		6
F	France		19	ROC	Taiwan		10
GB	Great Britain		21	ROK	South Korea		15
GR	Greece		15	S	Sweden		24
HK	Hong Kong		9	SA	Saudi Arabia		8
I	Italy		17	SF	Finland		24
IL	Israel		12	SGP	Singapore		5
IND	India		8	T	Thailand		6
IR	Iran		12	TA	Turkey		16
IRL	Ireland		22	USA	United States		16
IS	Iceland		26	YUG	Yugoslavia		18
J	Japan		14	YV	Venezuela		5
JOR	Jordan		11	ZA	South Africa		12
KWT	Kuwait		11				

<b>Mettler-Toledo (Albstadt) GmbH</b>	<b>D-72458 Albstadt</b>	<b>T 0049-7431-14 0</b>	<b>F -14 232</b>
<b>AT Mettler-Toledo Ges.m.b.H.</b>	1100 Wien	T 0043-1-604 19 80	F -604 28 80
<b>AU Mettler-Toledo Ltd.</b>	Victoria 3207	T 0061-3-9646 45 51	F -9645 39 35
<b>BE N.V. Mettler-Toledo S.A.</b>	1651 Lot	T 0032-2-334 02 11	F -378 16 65
<b>CH Mettler-Toledo (Schweiz) AG</b>	8606 Greifensee	T 0041-1-944 45 45	F -944 45 10
<b>CN Mettler-Toledo (Shanghai)Ltd.</b>	Shanghai 200233	T 0086-21-6485 0435	F -6485 3351
<b>CZ Mettler-Toledo spol, s.r.o.</b>	120 00 Praha 2	T 0042-2-252 755	F -242 475 83
<b>DE Mettler-Toledo GmbH</b>	35353 Giessen	T 0049-641-50 70	F -507 129
<b>DK Mettler-Toledo A/S</b>	2600 Glostrup	T 0045-43 27 08 00	F -43 27 08 28
<b>ES Mettler-Toledo S.A.E.</b>	08038 Barcelona	T 0034-3 223 22 22	F -223 02 71
<b>FR Mettler-Toledo s.a.</b>	78220 Viroflay	T 0033-1-30 97 17 17	F -30 97 16 00
<b>HK Mettler-Toledo (HK) Ltd.</b>	Kowloon, Hongkong	T 00852-2744 1221	F -2744 6878
<b>HR Mettler-Toledo d.o.o.</b>	100 10 Zagreb	T 0038-5-166 02 189	F -166 03 009
<b>HU Mettler-Toledo Keresked. KFT</b>	1173 Budapest	T 0036-1-257 98 89	F -258 07 88
<b>IT Mettler-Toledo S.p.A.</b>	20026 Novate Milanese	T 0039-2-33 33 21	F -356 2973
<b>JP Mettler-Toledo K.K.</b>	Osaka 540	T 0081-6-949 5917	F -949 5944
<b>KO Mettler-Toledo (Korea)</b>	Seoul 135-080	T 0082-2-528 1580	F -528 1583
<b>MY Mettler-Toledo (M)</b>	47301 Petaling Jaya	T 0060-3-703 2773	F -703 8773
<b>NO Mettler-Toledo A/S</b>	1008 Oslo 10	T 0047-22-30 44 90	F -32 70 02
<b>NL Mettler-Toledo B.V.</b>	4000 HA Tiel	T 0031-344-63 83 63	F -63 83 90
<b>PL Mettler-Toledo Sp.z.o.o.</b>	02-929 Warszawa	T 0048-22-651 92 32	F -42 20 01
<b>RC Mettler-Toledo Pac Rim AG</b>	Taipei	T 00886-2-579 5955	F -579 5977
<b>SE Mettler-Toledo AB</b>	120 08 Stockholm	T 0046-8-702 50 00	F -642 45 62
<b>SG Mettler-Toledo (S) Pte. Ltd.</b>	Singapore 139944	T 0065-778 67 79	F -778 66 39
<b>SK Mettler-Toledo spol, s.r.o.</b>	831 03 Bratislava	T 0042-7-5252 170	F -5252 173
<b>SL Mettler-Toledo d.o.o.</b>	611 11 Ljubljana	T 0038-6-611 236 764	F -127 45 75
<b>TH Mettler-Toledo (Thailand)</b>	Bangkok 10310	T 0066-2-719 64 80	F -719 64 79
<b>UK Mettler-Toledo Ltd.</b>	Leicester, LE4 1AW	T 0044-116-235 70 70	F -236 63 99
<b>US Mettler-Toledo Inc.</b>	Worthington, Ohio 43085	T 001-614-438 4511	F -438 4755
<b>US Mettler-Toledo Inc.</b>	Hightstown, NJ 08520	T 001-609-448 3000	F -586 5451
Other countries: Mettler-Toledo AG	8606 Greifensee	T 0041-1-944 22 11	F -944 31 70