

Installation information

METTLER TOLEDO MultiRange

MO600/MO1200 Overhead rail scales

METTLER TOLEDO

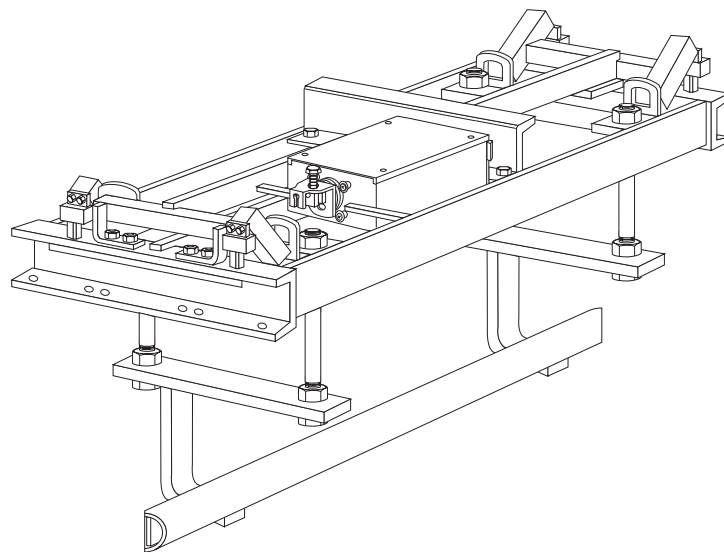

Contents		Page
1	Installation	2
1.1	Preparatory work	2
1.2	Assembling overhead rail scale	2
1.3	Transport locks / Rail carriers / Weighing rail insert.....	4
1.4	Installing connection cable	5
2	Configuration possibilities	6
2.1	General information	6
2.2	Configuration data	7
3	Appendix	8
3.1	Evaluation of supporting structure	8
3.2	Mounting possibilities	8
3.3	Dimensions of universal rail carrier with attached parts	10

1 Installation

1.1 Preparatory work

1.1.1 Selecting installation location



▲ The explosion-protected overhead-rail is approved for operation in Zone 2 (gases) and Zone 22 (dusts) hazardous areas. There is an increased danger of injuries and damage when using the overhead-rail in hazardous areas! Special care must be taken when working in such hazardous areas. The rules for behaviour are based on the concept of "Safe Distribution" established by METTLER TOLEDO.



Note

The local conditions must be clarified before beginning assembly.

→ First study the "Evaluation of supporting structure" and the related drawings in the Appendix.

ATTENTION

As METTLER TOLEDO has no knowledge of the local conditions, it shall bear no liability whatsoever for the fastening of the overhead rail scale to the tubular track support structure.

1.1.2 Accessories

- Completely unpack the accessories provided with the overhead rail.
- 1 Identcard
 - 1 Set of signs for selectable configurations
 - 1 Set of mounting parts
 - 1 Set of threaded rods

1.2 Assembling overhead rail scale

NOTE ON SAFETY

→ The assembly technician must make use of the equipment, carry out the instructions and take the measures for prevention of occupational accidents specified in the general and other applicable accident prevention regulations.

Mounting possibilities

The following mounting possibilities are illustrated in the Appendix:

- Tubular track support structure with double U-profile
- Tubular track support structure with double T-profile
- Special structure with support parallel to weighing rail insert
- Special structure with support perpendicular to weighing rail insert

**ATTENTION**

The selected support structure must be capable of bearing the load forces specified in the applicable dimensional drawing in the Appendix.

Proof of the load-bearing capacity must be confirmed by a building expert.

If the support structure does not meet these requirements, the overhead rail scale may not be installed.

1.2.1 Positioning overhead rail scale on and clamping to support structure

1. Lift the overhead rail scale and position it on the support structure provided by the customer.
2. Align the overhead rail scale on the support structure and clamp it on with the mounting elements. Depending on the tubular track support structure, refer to the corresponding drawing in the Appendix.

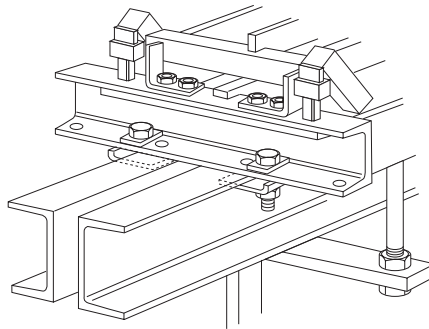

1.3 Transport locks / Rail carriers / Weighing rail insert

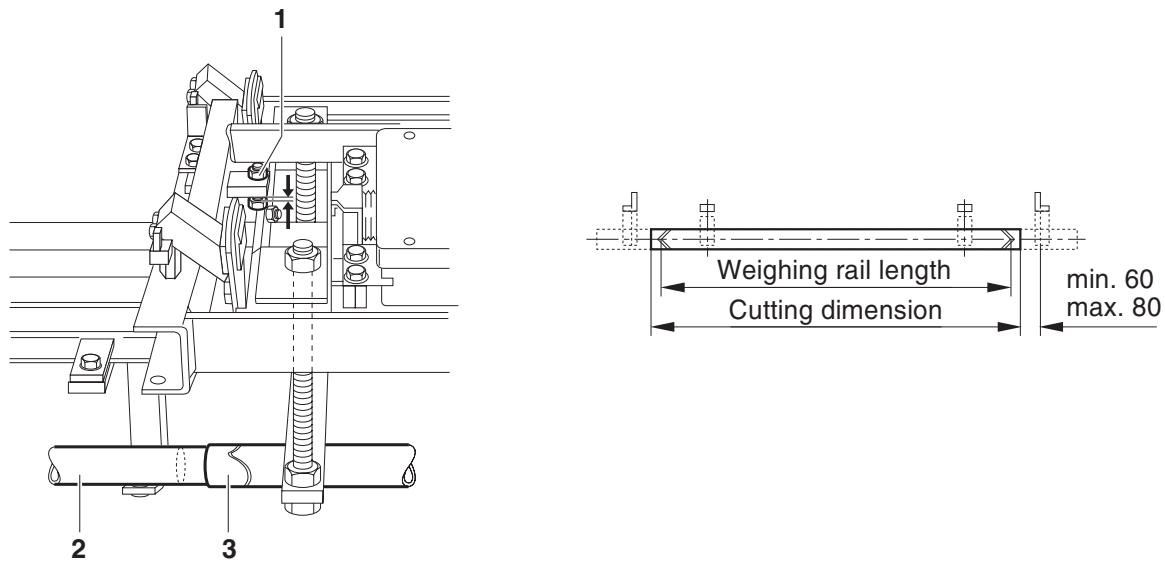

Releasing transport locks

→ Unscrew the bolts (1) on the left and right and adjust to 1 mm clearance, then lock.

Selecting rail carrier and weighing rail insert

Standard rail carrier Weighing rail insert lengths 800 mm and 1000 mm

Universal rail carrier Weighing rail insert lengths 200 mm, 400 mm and 600 mm

Preparing tubular track

1. Cut the tubular track (2) provided by the customer to length in accordance with the weighing rail insert length. To determine the length, measure the overhead rail scale and mark the scale centre on the tubular track with a plumb bob.

Weighing rail insert length (mm)	1000	800	600	400	200
Cutting dimension (mm)	1034	834	634	434	234

2. Screw on the tubular track connection pieces (3) while watching the vertical position. The connection pieces are designed with a spreading tension and can be used with inside tube diameters of 50.5 mm – 55.5 mm.

ATTENTION

The last suspension point of the stationary tubular track may be not more than 80 mm and not less than 60 mm from the weighing rail insert cut-out.

1.3.1 Mounting rail carrier and weighing rail insert

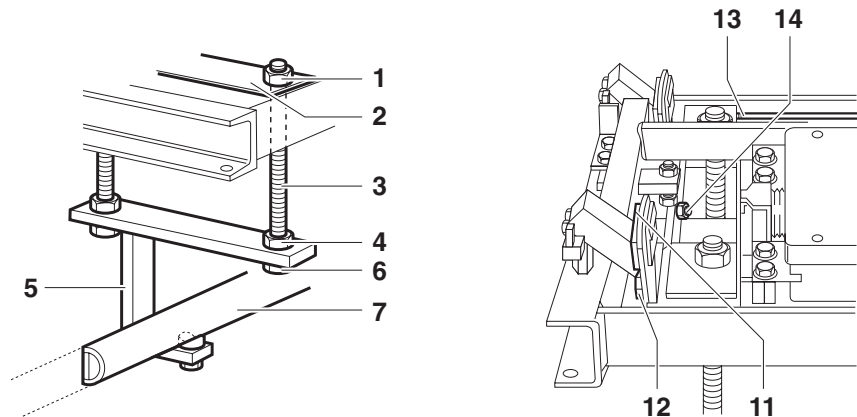

1. Screw the four threaded rods (3) into the mounting plates (2).
2. Screw on the nuts (1) from above and lock.
3. Screw in the lock nuts (4) on the four threaded rods.
4. Move into the threaded rods with the rail carrier (5) and tighten the nuts (6) on both sides.
5. Lay the spherical discs in the recesses of the standard rail carrier, centre the weighing rail insert (7) and screw on.
6. Adjust the weighing rail insert with the rail carrier horizontally and vertically relative to the tubular track provided by the customer.

Adjustment possibilities

- Height adjustment on threaded rods
- Adjustment of weighing rail insert on rail carrier
- Movement of entire overhead rail scale

Notes

- The hangers (11) must rest in the hinge pins (12).
- The hanging frame (13) may not tilt diagonally. Corrections can be made by adjusting the height of the rail carrier by moving upward with the rail carrier at the corner that tilts.
- Adjust the stop screws (14) so that the weighing rail insert does not contact the tubular track provided by the customer in the case of a stop in the longitudinal direction.
- Check all bolts and nuts for firm seating and tighten if necessary. Cut off protruding threaded rods.

1.4 Installing connection cable

Note

The connection cable may be lengthened to a maximum of 100 m.

- Route the connection cable to the terminal so that it is protected from possible damage.

2 Configuration possibilities

2.1 General information

2.1.1 MultiInterval

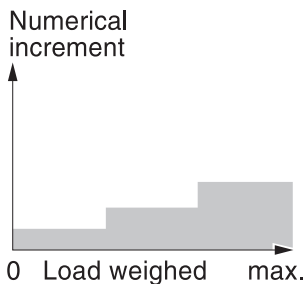

- MultiInterval precision means automatic switchover of the numerical increment (readability) in dependence on the applied load.
- All other adjustment variables (adjustment to the weighing process and vibrations, as well as adjustment of stability monitoring and the zero point correction) are adjusted to the usual user conditions, however can be changed in the master mode of the weighing terminal if necessary.

2.1.2 Single Range

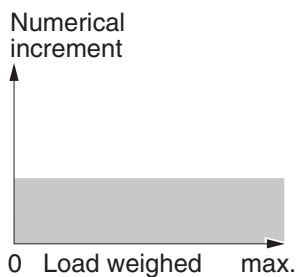

- Single Range means that the numerical increments (readability) remain the same across the entire weighing range.

2.1.3 Additional setting options

- All other adjustment variables (adjustment to the weighing process and vibrations, as well as adjustment of stability monitoring and the zero point correction) are adjusted to the usual user conditions, however can be changed in the master mode of the weighing terminal if necessary.
- The Identcard provided is labelled with the standard configuration. Mount the Identcard in accordance with the installation instructions of the weighing terminal concerned.
- If the standard configuration does not meet your needs, it is possible to reconfigure the weighing platform with the terminal. To do this, see the terminal operating instructions or the Service Manual A/D Converter Point.
- A set of measuring data signs is provided with the weighing platform. Apply the selected configuration corresponding to the factory-mounted measuring data sign to the Identcard, and the Max-Min sign near the terminal display.
- When the configuration is changed, it is also possible to change the preload range in addition to the weighing range and the readability.

2.2 Configuration data

2.2.1 Configuration data for M0, factory setting

Standard configuration	M0600	M01200
Maximum load	600 kg	1200 kg
Readability	0 ... 150 kg 0.05 kg 150 ... 300 kg 0.1 kg 300 ... 600 kg 0.2 kg	0 ... 300 kg 0.1 kg 300 ... 600 kg 0.2 kg 600 ... 1200 kg 0.5 kg
Tare range, subtractive	600 kg	1200 kg
Preload range Zero-set range Zero-set range (typ.)	± 12 kg 108 kg	± 24 kg 216 kg
Calibration data as per OIML		
Calibration class	III	III
Calibration value	0.05 kg	0.1 kg
Minimum load	1.0 kg	2.0 kg
Temperature range	-10 °C ... +40 °C	-10 °C ... +40 °C

3 Appendix

3.1 Evaluation of supporting structure

Calculation basis of occurring load forces

Tare weight of overhead rail scale	$G = 0.8 \text{ kN}$
Traffic load (max. load-bearing capacity)	$P = 15 \text{ kN}$
Assumed vibration coefficient	$J = 1.2$

Note

The traffic load can be set either as an uniformly distributed linear load with $P = 15 \text{ kN}$
 – or –
 as two individual loads with $P = 7.5 \text{ kN}$ at a minimum distance of 0.30 m

Load forces at maximum load

The tubular track supporting structure or the accompanying special structure must take up the following maximum load forces:

- With two individual loads in an unfavourable position and a tare weight of $F_{A\max} = 18.6 \text{ kN}$
- With a uniformly distributed linear load and a tare weight of $F_{A\max} = 9.6 \text{ kN}$

3.2 Mounting possibilities

3.2.1 Mounting on double U-carrier or double T-carrier with standard rail carrier

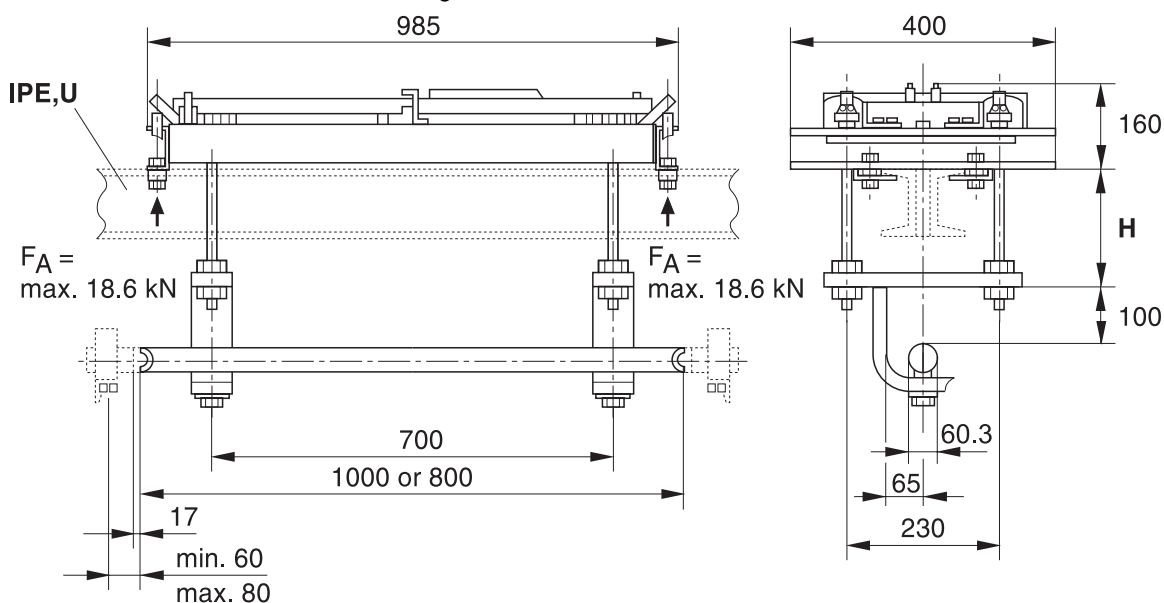

Dim. in mm

H Continuously adjustable up to 375 mm

U U-profiles as per DIN 1026, up to 140 mm

IPE IPE-profiles as per DIN 1026, up to 270 mm

Technical version: 08/00

3.2.2 Mounting with a carrier parallel to the overhead rail scale, overhead rail scale with standard rail carrier

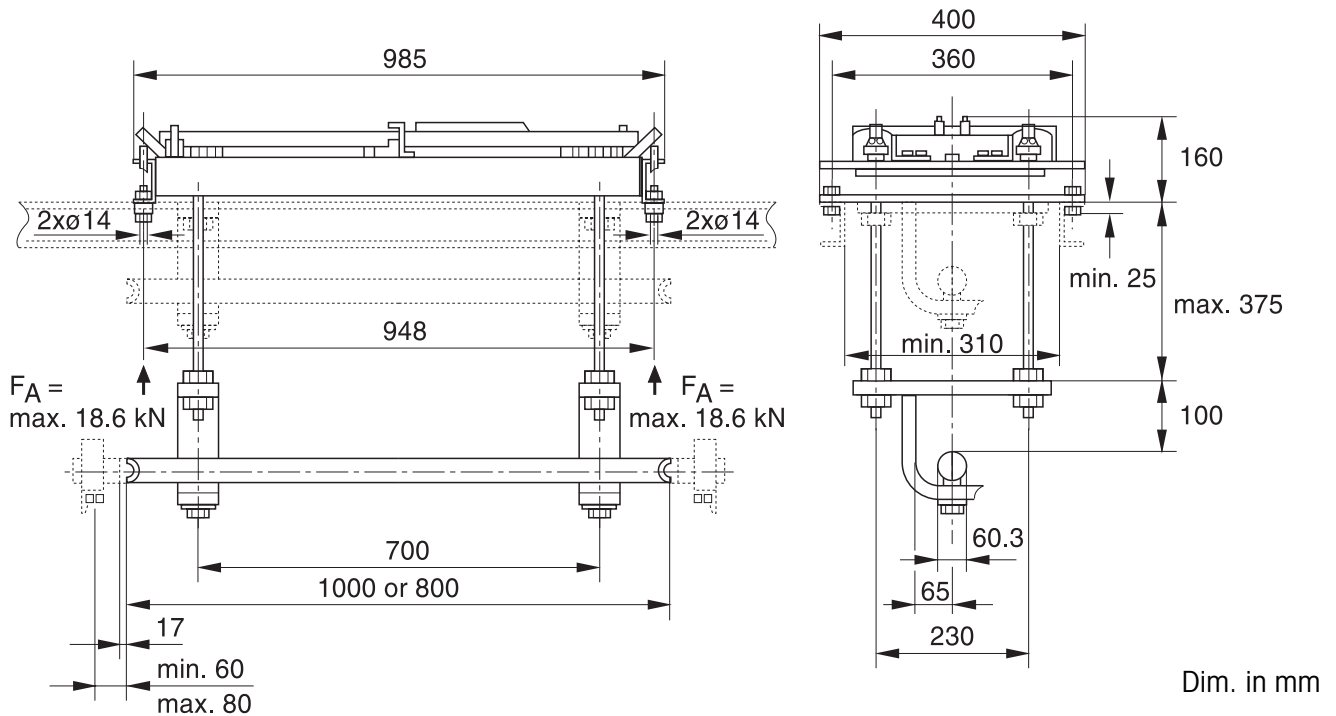

Technical version: 08/00

3.2.3 Mounting with a carrier perpendicular to the overhead rail scale, overhead rail scale with standard rail carrier

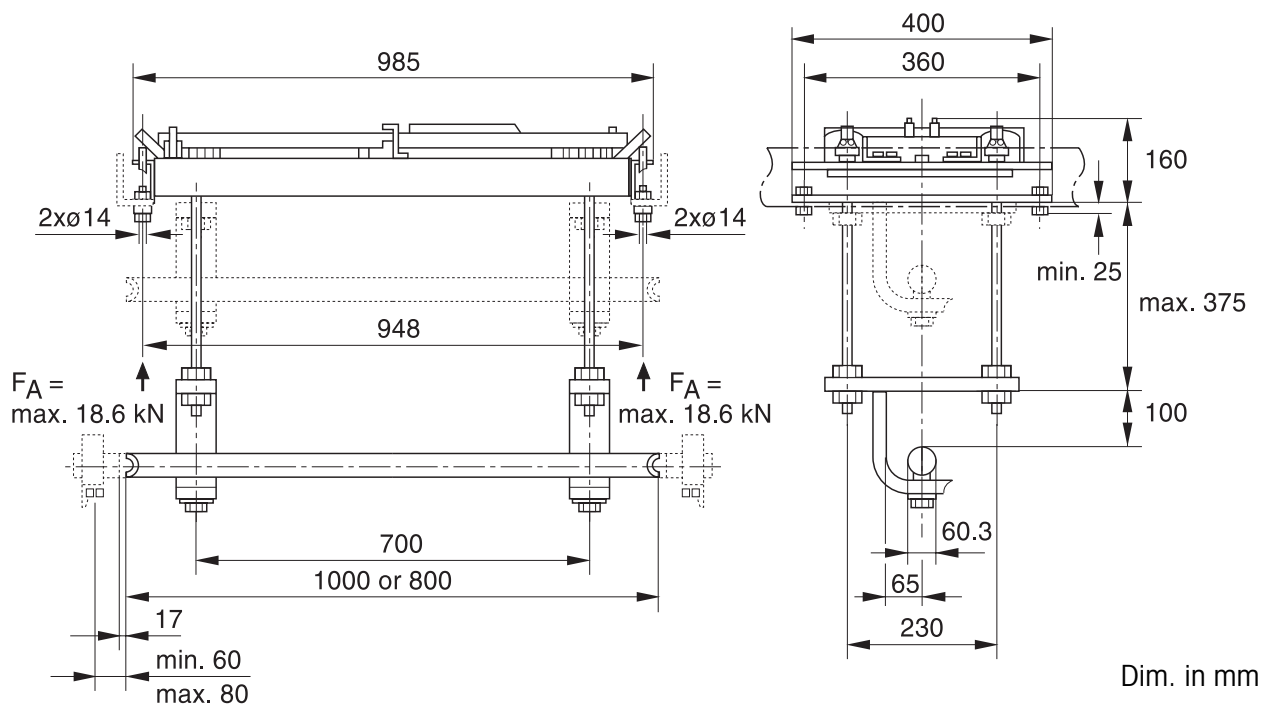

Technical version: 08/00

3.3 Dimensions of universal rail carrier with attached parts

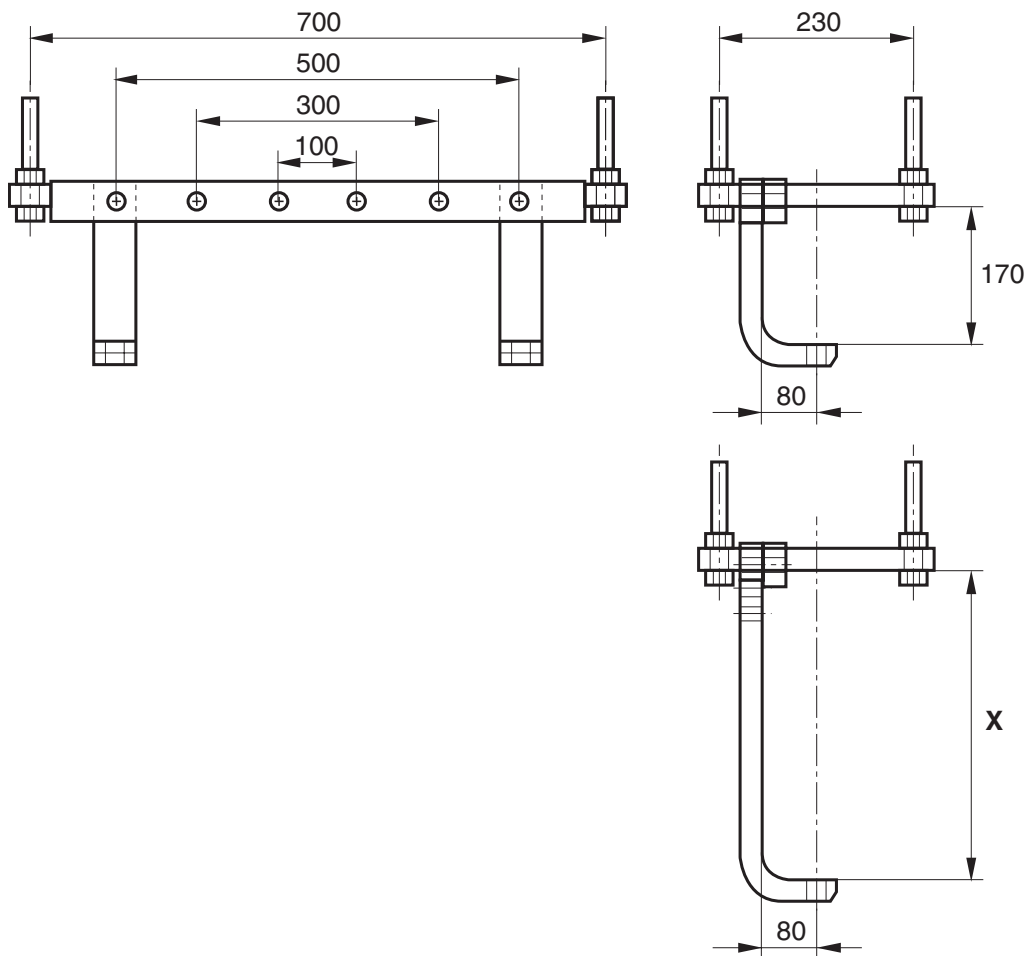

Dim. in mm

X Angled mounting bracket for use with chain conveyor
either 320 mm, 350 mm or 380 mm

Technical version: 08/00



22006501A

Subject to technical changes © Mettler-Toledo (Albstadt) GmbH 03/07 Printed in Germany 22006501A

Mettler-Toledo (Albstadt) GmbH

D-72458 Albstadt

Tel. ++49-7431-14 0, Fax ++49-7431-14 232

Internet: <http://www.mt.com>