

Automated Cell Counter

CytoDirect

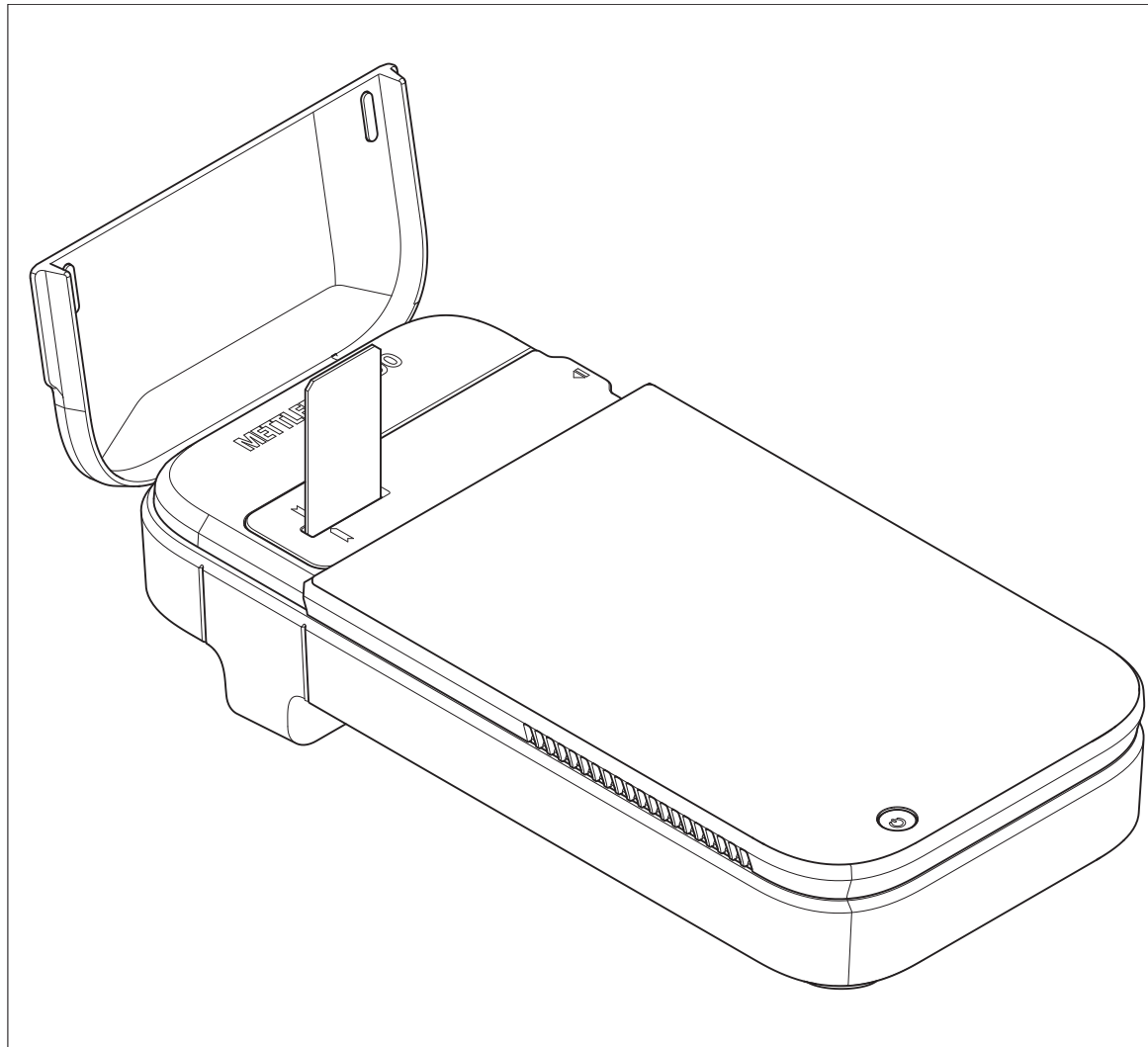

METTLER TOLEDO

Table of Contents

1	Introduction	3
1.1	Further documents and information	3
1.2	Explanation of conventions and symbols	3
1.3	Compliance information	3
2	Safety information	4
2.1	Definition of signal words and warning symbols	4
2.2	Product-specific safety notes	4
3	Design and function	6
3.1	Instrument overview	6
3.2	User interface	7
3.2.1	Home screen	7
3.2.2	Icons on the screen	7
3.3	Measurement principle	7
4	Installation	10
4.1	Scope of delivery	10
4.2	Unpack the instrument	10
4.3	Position the instrument	11
4.4	Charge the instrument	11
4.4.1	Assemble the AC/DC adapter	12
4.4.2	Connect and disconnect the power supply	12
4.4.2.1	Connect the power supply	12
4.4.2.2	Disconnect the power supply	12
4.5	Start up and shut down the instrument	12
4.6	Configure the instrument	13
4.6.1	Configure the language	13
4.6.2	Configure network connection	13
4.6.2.1	Configure ethernet connection	13
4.6.2.2	Configure Wi-Fi connection	14
4.6.3	Configure date and time	14
4.6.3.1	Configure via network	14
4.6.3.2	Configure manually	14
4.7	Network requirements	15
4.8	Use biohazard sticker (Optional)	15
5	Operation	16
5.1	Define measurement parameters	16
5.1.1	Application	16
5.1.2	User-defined method	16
5.1.2.1	Create a method	16
5.1.2.2	Edit and delete a method	17
5.2	Perform a measurement	18
5.3	Results	20
5.3.1	Results overview	20
5.3.2	View results	22
5.3.3	Export results	22
5.3.4	Delete results	25
6	Maintenance	25
6.1	Maintenance schedule	25
6.2	Clean the instrument	26
6.2.1	Clean the housing	26
6.2.2	Clean the slide adapter	27
6.2.3	Clean the slide adapter slot	28

6.2.4	Clean the sensor	29
6.3	Check the workflow accuracy.....	30
6.3.1	Configure the test	30
6.3.2	Perform the test	30
6.4	Update the firmware.....	31
6.5	Prepare the instrument for storage	31
6.6	Dispose of the instrument.....	31
<hr/>		
7	Troubleshooting	32
7.1	List of errors and problems.....	32
7.2	View the firmware version and other system information	33
<hr/>		
8	Technical data	34
8.1	Instrument	34
8.2	Slide	35
8.3	Measurement.....	35
<hr/>		
9	Accessories, spare parts and consumables	35

1 Introduction

Thank you for choosing a METTLER TOLEDO CytoDirect™ automated cell counter. CytoDirect is a portable instrument used for cell counting and viability assessment.

This document provides you with the information you need to get started with your automated cell counter.

This document applies to the firmware version 9.2.1 or higher.

The firmware license is subject to the End User License Agreement EULA. See the following link for the license text:

▶ www.mt.com/EULA

1.1 Further documents and information

For application notes, see the following link:

▶ www.mt.com/library

For third party licenses and open source attribution files, see the following link:

▶ www.mt.com/licenses

If you have any additional questions, contact your authorized METTLER TOLEDO service representative or dealer.

▶ www.mt.com/contact

1.2 Explanation of conventions and symbols



Refers to an external document.

Elements of instructions

Instructions always contain action steps and can contain prerequisites, intermediate results and results. If an instruction contains more than one action step, the action steps are numbered.

- Prerequisites that must be fulfilled before the individual action steps can be executed.

- 1 Action step 1
 - ➔ Intermediate result
- 2 Action step 2
 - ➔ Result

1.3 Compliance information

National approval documents, e.g., the FCC Supplier Declaration of Conformity, are available online and/or included in the packaging.

▶ www.mt.com/ComplianceSearch

Contact METTLER TOLEDO for questions about the country-specific compliance of your instrument.

▶ www.mt.com/ComplianceSearch

European Union

The instrument complies with the directives and standards listed on the Declaration of Conformity.

This product may contain SVHC candidate substances according to Article 33 of the EU regulation no. 1907/2006 (REACH). SVHC candidate substances are listed on the Declaration of Conformity (DoC).

▶ <https://www.mt.com/doc>

Canada

This device contains licence-exempt transmitter(s)/receiver(s) that comply with Innovation, Science and Economic Development Canada's licence-exempt RSS(s). Operation is subject to the following two conditions:

1. This device may not cause interference.
2. This device must accept any interference, including interference that may cause undesired operation of the device.

Singapore

The instrument complies with the standards and specifications published by IMDA.

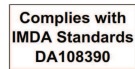

2 Safety information

A document named "User Manual" is available for this instrument.

- A QR code for downloading the User Manual is delivered with the instrument.
- The electronic User Manual contains a description of the instrument and its use.
- Keep this document for future reference.
- Include this document if you transfer the instrument to other parties.

Only use the instrument according to the User Manual. If you do not use the instrument according to this document or if the instrument is modified, the safety of the instrument may be impaired, and Mettler-Toledo GmbH assumes no liability.

2.1 Definition of signal words and warning symbols

Safety notes contain important information on safety issues. Ignoring the safety notes may lead to personal injury, damage to the instrument, malfunctions and false results. Safety notes are marked with the following signal words and warning symbols:

Signal words

WARNING	A hazardous situation with medium risk, possibly resulting in death or severe injury if not avoided.
CAUTION	A hazardous situation with low risk, resulting in minor or moderate injury if not avoided.
NOTICE	A hazardous situation with low risk, resulting in damage to the instrument, other material damage, malfunctions and erroneous results, or loss of data.

Warning symbols



General hazard



Notice



Biohazard

2.2 Product-specific safety notes

Intended use

The instrument is designed to be used in laboratories by trained staff and is intended to count the number of cells and assess their viability. The typical work environment for the instrument is a life-science laboratory, often a quality control laboratory in academic and industrial settings.

The instrument can provide information on the cell count (CC) and cell viability (VIA) of various cell types in suspension. For more information, see the following link:

► www.mt.com/CytoDirect-Cell-List

The instrument is suitable for samples with the following characteristics:

- Compatible with the materials they come into contact with
- Free of air bubbles

Any other type of use and operation beyond the limits of use stated by Mettler-Toledo GmbH without consent from Mettler-Toledo GmbH is considered as not intended.

Prohibitions on use

The instrument should not be used:

- For medical diagnostics.
- In potentially explosive environments.
- With hazardous substances (corrosive, flammable).
- With hot liquids (> 60 °C).

Responsibilities of the instrument owner

The instrument owner is the person holding the legal title to the instrument and who uses the instrument or authorizes any person to use it, or the person who is deemed by law to be the operator of the instrument. The instrument owner is responsible for the safety of all users of the instrument and third parties.

Mettler-Toledo GmbH assumes that the instrument owner trains users to safely use the instrument in their workplace and deal with potential hazards. Mettler-Toledo GmbH assumes that the instrument owner provides the necessary protective gear.

Safety notes



WARNING

Death or serious injury due to electric shock

Contact with parts that carry a live current can lead to death or injury.

- 1 Only use the METTLER TOLEDO AC/DC adapter designed for your instrument.
- 2 Keep all electrical cables and connections away from liquids and moisture.
- 3 Check the cables and the plugs for damage and replace damaged cables and plugs.



CAUTION

Slight injuries from exposure to laser radiation

A laser LED (Class I) is used as a light source in the instrument. If the light source is activated when no slide or slide adapter is inserted, looking directly into the laser light can cause slight injuries to the eyes.

- 1 Never look directly into the light source.
- 2 Discontinue the use of the instrument immediately.
- 3 Seek support for repair or replacement of the instrument.



NOTICE

Damage to the instrument or malfunction due to the use of unsuitable parts

- Only use parts from METTLER TOLEDO that are intended to be used with your instrument.

3 Design and function

3.1 Instrument overview

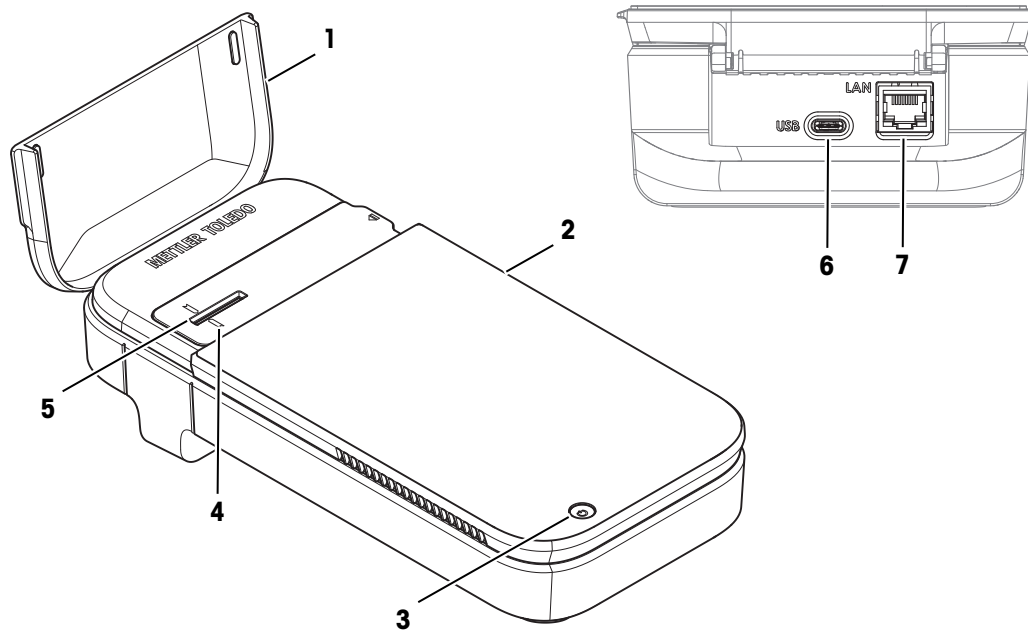

No.	Name	Function
1	Lid	Protect the slide adapter slot
2	Screen	Display and enter information
3	Power button	Start up and shut down the instrument
4	Alignment mark	Align slide with measurement position
5	Slide adapter	Position for slide during measurement
6	USB-C socket	Connect the instrument with AC/DC adapter for charging
7	Ethernet	RJ45 socket for LAN connection

RFID Cards

The instrument is equipped with an RFID Reader. RFID Tags will be included in the test kits and are directly attached to the slide box and will be necessary for performing all testing procedures. They contain lot, expiration data, number of tests and calibration data, if applicable. The instrument will request the scanning of a RFID tag after entering all application parameters or after starting a measurement from the method list.

3.2 User interface

3.2.1 Home screen

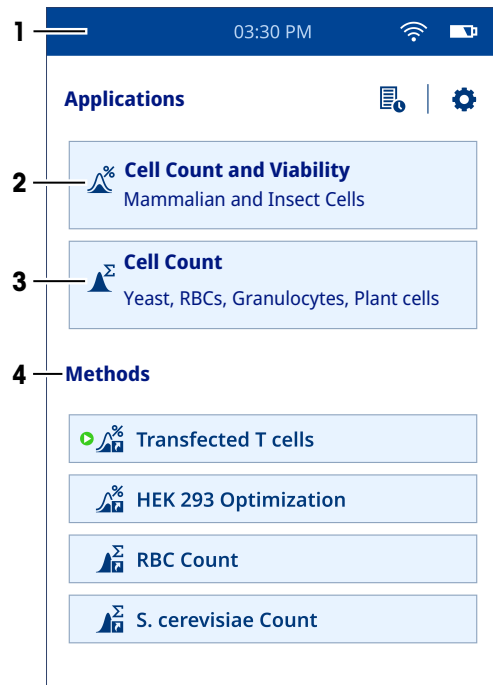

No.	Name	Explanation
1	Status ribbon	Displays the current time, network connection status, and battery charge status.
2	Cell Count and Viability	Application for measuring cell count and viability. The user can define the parameters as required.
3	Cell Count	Application for measuring cell count. The user can define the parameters as required.
4	Methods	User-defined methods are displayed in this area. The user can define, save, edit, and delete these in the Method Editor option under the Settings menu.

3.2.2 Icons on the screen

Icon	Location	Explanation
	Status ribbon	A connection to LAN is established via Wi-Fi.
	Status ribbon	A connection to LAN is established via ethernet.
	Status ribbon	Shows the charging status of the battery.
	Home screen	Displays the results obtained for the measurements performed on the instrument.
	Home screen	Shows the Settings menu.

3.3 Measurement principle

The instrument uses a combination of technologies to measure cell count and viability: Digital Holographic Microscopy (DHM) for image acquisition and Convolutional Neural Networks (CNN) for the image analysis. Contrary to the conventional standard brightfield microscopy technique, DHM does not use optical lenses to

record the image of the object (sample). Instead, a hologram is generated based on the diffraction pattern of the object, which is then used by a computer to reconstruct a high-resolution image. Thus, the image-forming lens in traditional microscopy is replaced by a computer algorithm. These images are further analyzed by using a supervised artificial intelligence algorithm (CNN). The result is a staining-free approach to cell count and viability measurement.

Digital Holographic Microscopy

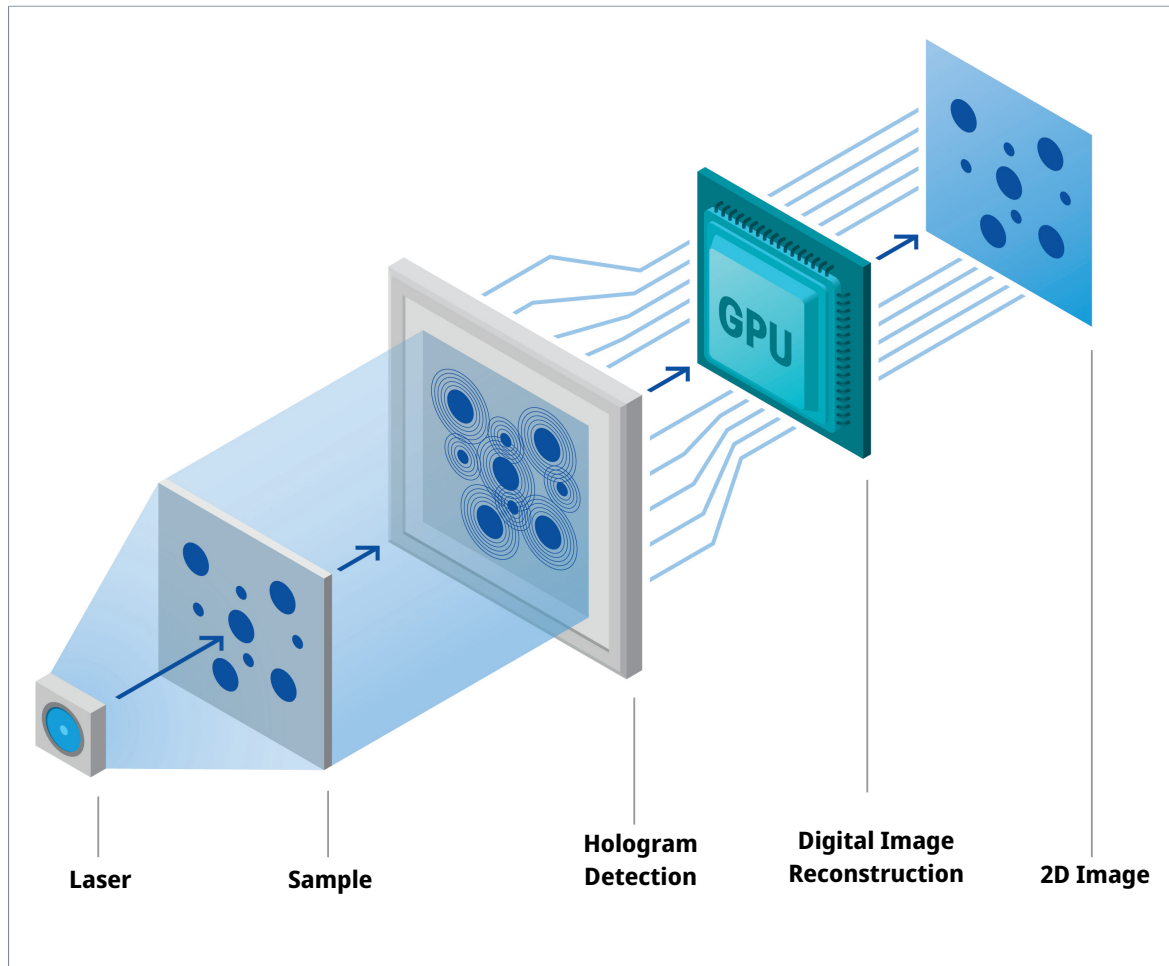

DHM is a state-of-the-art quantitative phase imaging technique where the sample is illuminated with laser light. As light passes through the sample, it gets diffracted, creating a so-called hologram that is recorded by a digital sensor. The hologram is then processed by a mathematical reconstruction software based on the Fresnel-Kirchhoff diffraction formula to deliver a high-resolution image. As the images created using the DHM imaging technology are based on capturing the refractive index of a sample, they can reveal subtle variations at interfaces such as membranes or protein-rich compartments. This makes this technology highly suitable for determining sensitive cellular events such as cell death.



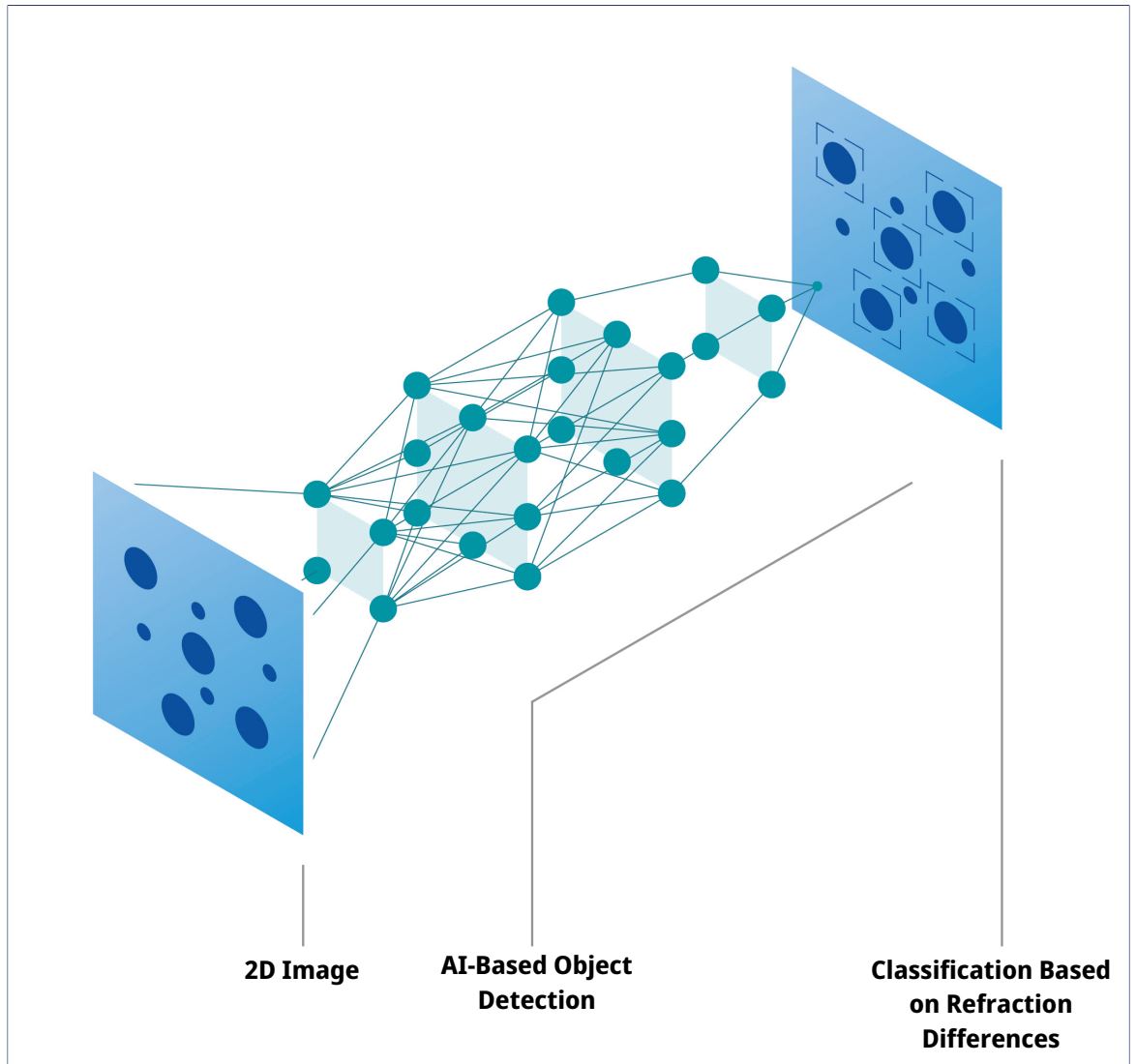

Convolutional neural network

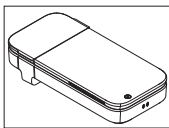
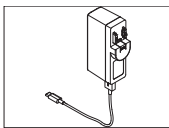
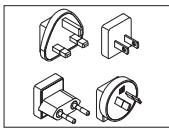
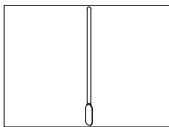

This artificial intelligence algorithm has the ability to recognize patterns in the images. The basic structure of a neural network comprises of an input layer, hidden layers, and an output layer. The reconstructed image is given as an input and then transferred to multiple hidden layers, which subsequently process the image. Finally, the output layer produces a probability distribution over the defined classes and the detected object is placed in the class for which the object scores the highest probability. In the process of analyzing the reconstructed image, a CNN initially performs object detection to identify all the objects present in the image and distinguishes them from the background. The network then classifies these objects into cells and debris/artifacts. Further, the cells are analyzed and categorized as live or dead, based on their characteristics. In summary, the automated cell counter enables staining-free cell count and viability measurements in under 15 seconds as efficiently and precisely as staining based viability assessment methods.

4 Installation

4.1 Scope of delivery

Part	Order number
 CytoDirect instrument	—
 AC/DC adapter with cable	30937782
 Prong (Country-specific)*	30671583
 Cleaning swab (12 pcs)	30937107
 Safety information datasheet	—
 Test report	—
 Biohazard sticker	—

*Only one prong specific to the country will be delivered with the instrument.

Note: To request 'Charger' as a spare part, include both 'AC/DC adapter with cable' and 'Prong' in the order.

4.2 Unpack the instrument

The instrument is in shipping mode when delivered to the user. This chapter describes how to unpack the instrument and switch it on for the first time.

Procedure

- 1 Remove the instrument from the protective packaging.
- 2 Store the protective packaging for later transport over long distances.
- 3 Check that you have received all parts listed in the [scope of delivery ▶ Page 10].
- 4 Inspect the parts visually for flaws or damage.
- 5 If parts are missing or damaged, report it to your authorized METTLER TOLEDO service representative or dealer.

▶ www.mt.com/contact

- 6 Assemble the AC/DC adapter. See [Assemble the AC/DC adapter ▶ Page 12].
- 7 Connect the instrument to the power supply. See [Connect the power supply ▶ Page 12].

- ➔ The power button of the instrument lights up briefly.
 - ➔ The instrument is no longer in shipping mode and is ready to use.
- 8 Disconnect the instrument from the power supply. See [Disconnect the power supply ▶ Page 12].

4.3 Position the instrument

The instrument has been developed for indoor operation in a well-ventilated area.

The following site requirements apply:

- Ambient conditions within the limits specified in the technical data
- No powerful vibrations
- No direct sunlight
- No corrosive gas atmosphere
- No explosive atmosphere
- No powerful electric or magnetic fields

Procedure

- Place the instrument on a stable, flat and fire-resistant surface.
- Make sure that nothing blocks the air vent of the instrument.

See also

 Technical data ▶ Page 34

4.4 Charge the instrument

The instrument is suitable for 24/7 use, provided it is connected to the AC/DC adapter. The battery life limits the portable use. If the battery is low (20 % remaining capacity), the battery icon on the status ribbon turns red . In such a case, you should immediately charge the instrument. If you fail to do so, the instrument will shut down automatically when the remaining battery capacity falls to 5 %. You can use the supplied AC/DC adapter for charging purpose. Recharging an empty battery takes approximately 3 hours. The instrument can be switched on and used for measurements during the charging process. It is not necessary to wait until the battery is fully charged before switching on the instrument.



WARNING

Death or serious injury due to electric shock

Contact with parts that carry a live current can lead to death or injury.

- 1 Only use the METTLER TOLEDO AC/DC adapter designed for your instrument.
- 2 Keep all electrical cables and connections away from liquids and moisture.
- 3 Check the cables and the plugs for damage and replace damaged cables and plugs.



CAUTION

Injury or damage by touching bottom of the instrument

The charging process may cause the bottom of the instrument to heat up.

- Do not touch the bottom of the instrument while charging.



NOTICE

Damage to the AC/DC adapter due to overheating

An AC/DC adapter that does not have adequate air circulation around it, cannot cool sufficiently and overheats.

- Do not cover the AC/DC adapter.

The AC/DC adapter is suitable for all supply line voltages ranging from 100 to 240 V AC and 50 to 60 Hz.

4.4.1 Assemble the AC/DC adapter

Install the prongs

- 1 Slide the prong (1) into the AC/DC adapter (2).
- 2 Insert the USB-A plug of the USB-A-C cable in the USB-A socket of the AC/DC adapter.

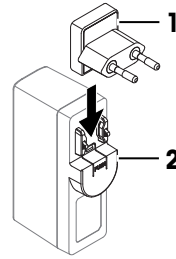

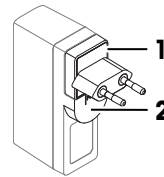

Change the prongs

- 1 Pull the plug of the AC/DC adapter out of the power outlet.
- 2 Push the button (2) and slide the prong (1) out.
- 3 Slide the desired prong into the AC/DC adapter.



4.4.2 Connect and disconnect the power supply

4.4.2.1 Connect the power supply

- 1 Insert the plug of AC/DC adapter into a power outlet that is easily accessible.
- 2 Insert the USB-C end of the USB A-C cable into USB-C socket (1).
 - ➔ The instrument starts charging and charging icon is displayed  on the instrument screen.
 - ➔ The battery is fully charged when the battery icon is full .

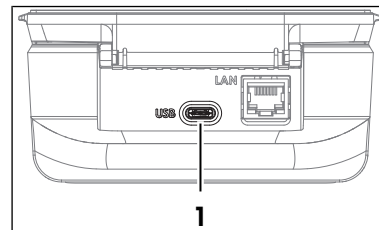

4.4.2.2 Disconnect the power supply

- 1 Pull the USB cable out of the USB-C socket of the instrument.
- 2 Pull the plug of the AC/DC adapter out of the power outlet.

4.5 Start up and shut down the instrument

Start up

- Press and hold the power button (1) for approximately one second and then release it.
 - ➔ The home screen opens.
 - ➔ The instrument is ready to use.

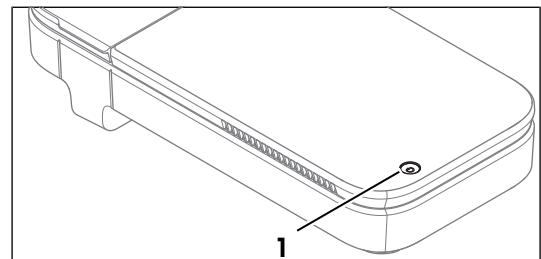

Shut down

- 1 Press and hold the power button for approximately one second.
 - ➔ A selection menu appears on the screen.

- 2 Select **Yes, Switch off**.
 - ➔ The screen goes dark.
 - ➔ The instrument shuts down.

Hard shut down

- Long press the power button for at least 7 seconds.
 - ➔ The screen goes dark.
 - ➔ The instrument shuts down.

4.6 Configure the instrument

4.6.1 Configure the language

The text on the screen can be displayed in different languages. You can select one of the languages as required.

To set a different display language, follow the procedure given below:

- The home screen is open.
- 1 Go to **Settings > System and Maintenance > Language**.
 - 2 Select the desired language by tapping on the relevant option.
 - ➔ The selected language is used on the screen and printouts.

4.6.2 Configure network connection

A connection to LAN can be established via ethernet or Wi-Fi. This network connection is useful for accessing data from the instrument.

4.6.2.1 Configure ethernet connection

- The home screen is open.
- 1 Connect an ethernet cable to the ethernet port (1) on the instrument.
 - 2 Go to **Settings > Network Connection > Configure Ethernet Connection** and configure the parameters as explained below.

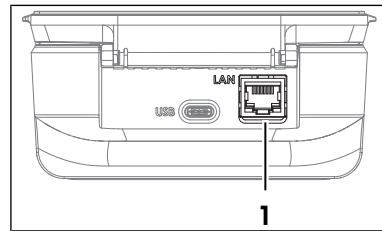

Parameter	Description	Values
Ethernet DHCP Active	Indicates whether the IP address should be automatically obtained over the network.	Active Inactive
IP address	If the IP address is not to be automatically obtained, you can enter it here.	000.000.000.000 ... 255.255.255.255
Subnet mask	If you want to run the instrument on a local subnetwork, you can define the subnet mask here that you want to use to link the subnet's IP address.	000.000.000.000 ... 255.255.255.255
Gateway	Defines the address of the standard gateway for communication between the various networks.	000.000.000.000 ... 255.255.255.255
DNS Server	Defines the IP address of Domain Name System server.	000.000.000.000 ... 255.255.255.255

- 3 Tap **Save**.
 - ➔ The network connection is established successfully.
 - ➔ This is indicated with  icon on the status ribbon of screen.

4.6.2.2 Configure Wi-Fi connection

- The home screen is open.
- 1 Go to **Settings > Network Connection**.
- 2 Select the **Wi-Fi** option (1).
 - ➔ The list of available Wi-Fi networks is displayed.
- 3 Select the desired Wi-Fi network.
 - ➔ You are prompted to insert the **Password**.
- 4 Insert the **Password**.
- 5 Tap **Save Changes**.
 - ➔ The network connection is established successfully.
 - ➔ This is indicated with **Wi-Fi** icon on the status ribbon of screen.

It is also possible to add a new Wi-Fi network with **Other Wi-Fi** option (2) by configuring the parameters given below.

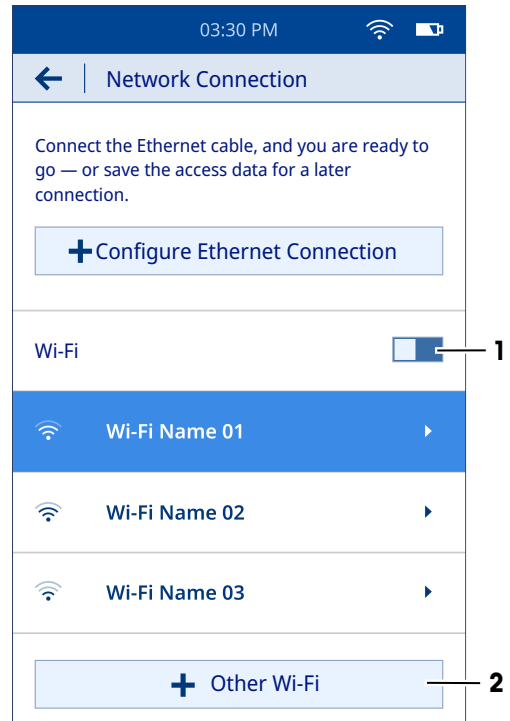

Parameter	Description	Values
SSID	A sequence of characters that uniquely names a wireless network.	Character
Password	A security word or phrase to be entered for establishing connection with the wireless network.	Character

- Tap **Connect**.
- ➔ The name of newly added network is displayed in the list of available Wi-Fi networks.

4.6.3 Configure date and time

There are two options to set the date and time, via network or manually.

4.6.3.1 Configure via network

- The instrument is connected to the network.
- The home screen is open.
- Go to **Settings > System and Maintenance > Date and Time**.
- ➔ The instrument automatically displays the date and time provided by the network.

See also

[Configure network connection](#) ▶ Page 13

4.6.3.2 Configure manually

- The home screen is open.
- 1 Go to **Settings > System and Maintenance > Date and Time**.

- 2 Tap (1) to turn off the **Use Network-Provided Date and Time** option.
 - 3 To set the date, tap (2) and scroll through the available options until you find the desired date.
 - 4 To set the time, tap (3) and scroll through the available options until you find the desired time.
 - 5 Tap (4) to choose between one of the available time formats, 24-hour or 12-hour.
 - 6 To select a timezone, tap (5) and scroll through the available options until you find a suitable timezone based on your country.
- ➔ The selected date and time are displayed on the screen.

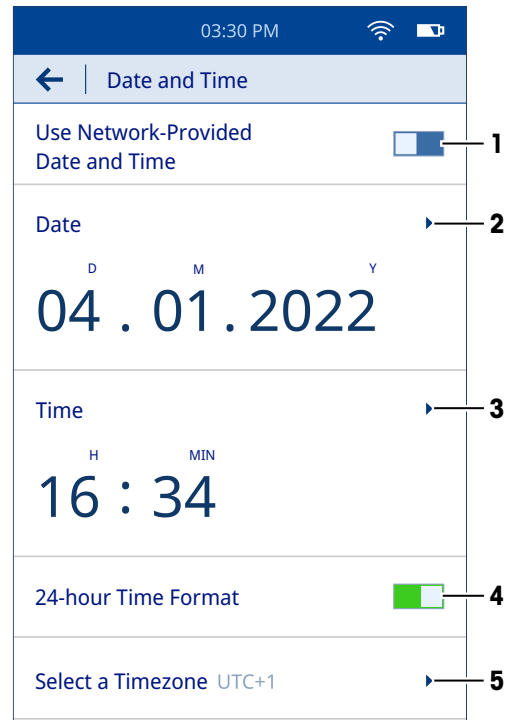

4.7 Network requirements

This chapter describes the network requirements for the correct functioning of the instrument.

Data transfer

The instrument uses HTTP port TCP 80 for data transfer over Webserver from instrument to a computer in the local area network.

Firmware update

The instrument uses HTTPS port TCP 443 for the update process.

The following URLs and access types need outgoing permissions in firewalls to ensure that update process works correctly:

- <https://eu.hosted.mender.io>
- https://*.eu.hosted.mender.io
- <https://mender.blob.core.windows.net/artifacts>
- <https://c271964d41749feb10da762816c952ee.r2.cloudflarestorage.com>

4.8 Use biohazard sticker (Optional)

If you intend to work with biohazardous material, you are obligated to have the biohazard symbol on the slide adapter of the instrument. This is to warn other potential users of the danger.

- Stick the biohazard sticker next to the slot on the slide adapter of the instrument.



WARNING

Serious disease from exposure to biohazardous material

Contact with biohazardous material can cause serious disease.

- 1 Wear personal protective equipment to ensure safety of the user.
- 2 Stick the biohazard sticker on the slide adapter of the instrument to warn the user of danger.

In case the instrument comes in contact with biohazardous material, follow the instructions given below depending on the contaminated instrument part:

- Clean the housing. See [Clean the housing ▶ Page 26]
- Clean the slide adapter. See [Clean the slide adapter ▶ Page 27]
- Clean the slide adapter slot. See [Clean the slide adapter slot ▶ Page 28]
- Clean the sensor. See [Clean the sensor ▶ Page 29]

See also

 Scope of delivery ▶ Page 10

5 Operation



5.1 Define measurement parameters

There are two ways to define the measurement parameters.

- Application: This is a quick launch option, where you can set the parameters and start the measurement immediately. However, it is not possible to save the parameters for later use.
- User-defined method: With this option, you can pre-set the parameters and save them for later use.

5.1.1 Application

There are two applications available on the home screen.

-  **Cell Count and Viability (VIA)**
-  **Cell Count (CC)**

Procedure

- The home screen is open.
- 1 Select a suitable application as per the requirement.
 - ➔ An automated sensor check is performed.
 - ➔ A **Parameter Setup** screen opens.
 - 2 Define the parameters as explained below.





Parameter	Explanation	Values
Test Name	Defines the name of the method.	Character (1 to 50)
Cell Type	Defines the type of cell.	Character (1 to 50)
Dilution Factor	Defines the dilution factor in the form of '1:x'. For example, the value will be '1:10' for 1 part sample and 9 parts diluent.	$1 \geq x \leq 1000$

5.1.2 User-defined method

5.1.2.1 Create a method

This chapter describes how to create new methods. The newly created methods are displayed in the method list as well as on the home screen. If there are no methods saved by the user, the method list will be empty.

Procedure

- The home screen is open.
- 1 Go to  **Settings** >  **Method Editor** > **Create New Method**.
 - ➔ A selection menu appears on the screen.
 - 2 Select a suitable option between  **Cell Count and Viability** and  **Cell Count**.
 - 3 Define the parameters as explained below.

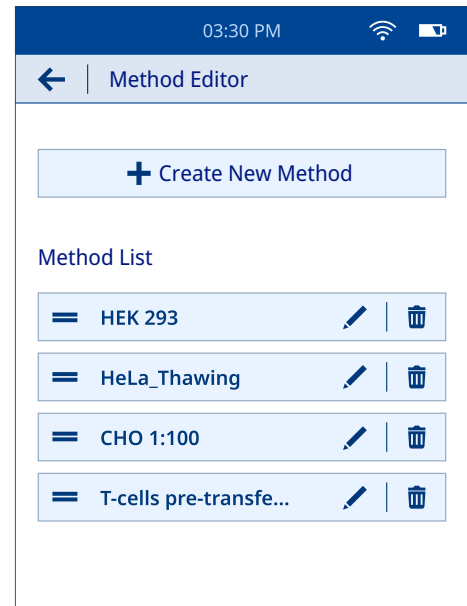

Parameter	Explanation	Values
Method Name	Defines the name of the method.	Character (1 to 50)
Cell Type	Defines the cell type.	Character (1 to 50)
Dilution Factor	Defines the dilution factor in the form of '1:x'. For example, the value will be '1:10' for 1 part sample and 9 parts diluent.	$1 \geq x \leq 1000$
Immediate Start	Defines if the measurement starts immediately. Active: The method parameters are not shown on the screen before starting the measurement. Such methods are labelled with  when displayed in the method list. Inactive: The method parameters are shown on the screen before starting the measurement.	Active Inactive

- 4 Select **Save As New Method**.
- ➔ The saved method is displayed in the method list as well as on the home screen.
- 5 Drag  icon to position the frequently used methods to the most accessible place in the method list.



5.1.2.2 Edit and delete a method

Edit method

- The home screen is open.
- 1 Go to  **Settings** >  **Method Editor**.
 - ➔ The user-defined methods are displayed in the method list.
- 2 Navigate to the method you want to edit and select  icon.
- 3 Edit the method parameters as required.

- 4 Select (1) to save the edited method as a new method.
 - ➔ The modified method is displayed as a new method in the method list.
- 5 Select (2) to overwrite the original method.
 - ➔ The original method is replaced with modified method in the method list.

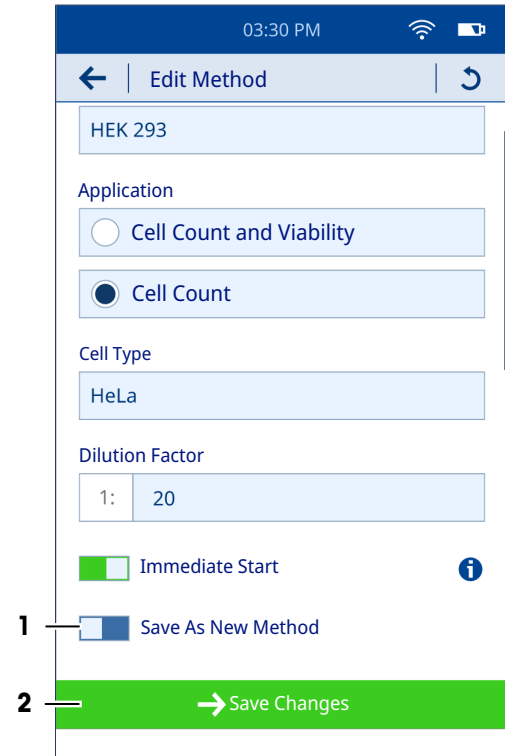

Delete method

- The home screen is open.
- 1 Go to **Settings** > **Method Editor**.
 - ➔ The user-defined methods are displayed in the method list.
 - 2 Navigate to the method you want to delete and select icon.
 - ➔ A selection menu appears on the screen.
 - 3 Select **Yes, Delete Method**.
 - ➔ The selected method is removed from the method list.

5.2 Perform a measurement



NOTICE

Erroneous results due to the use of incorrect slide adapter

The instrument is calibrated to provide accurate results only when used together with its provided slide adapter. Using a slide adapter of different instrument lead to erroneous results.

- Only use a slide adapter that is provided with the given instrument.

The user can proceed with the measurement directly, provided the cell suspension has a concentration between 10^4 and 10^7 cells/mL. If this is not the case, the sample should be diluted with a suitable solvent. Besides this, it is recommended not to shake or vortex the sample to avoid overlapping of the cells. Always use the slide delivered with the instrument with a valid expiry date and avoid touching the readout area on the slide.

Procedure

- 1 Select a suitable template from the **Applications** or **Methods** options on the home screen.
- 2 Tap **Next**.
 - ➔ The **Instructions** screen opens.

- 3 Take out a slide from the box and put it on a clean, smooth surface.

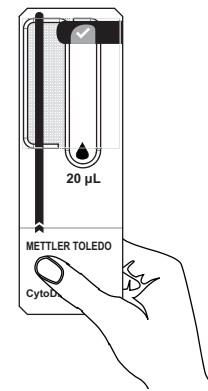

- 4 Mix the sample by gently inverting the tube/container at least 4x to resuspend the cells.

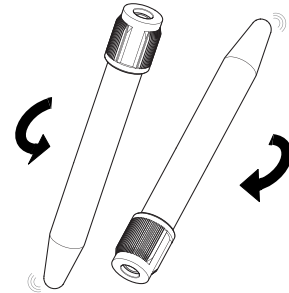

- 5 Draw 20 µL of the sample into the micropipette. Ensure that there is no air trapped in the sample.
6 Place the micropipette tip on the drop symbol (1) of the slide.
7 Carefully pipette the sample until the readout area is filled with the sample up to the checkmark symbol (2) on the slide.

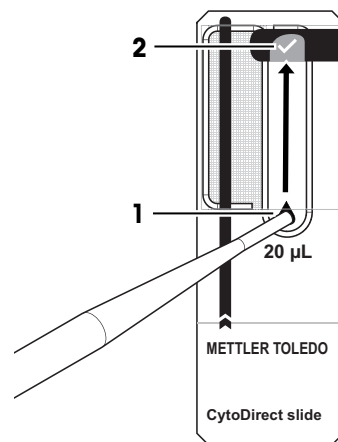

- 8 Open the instrument lid (1).

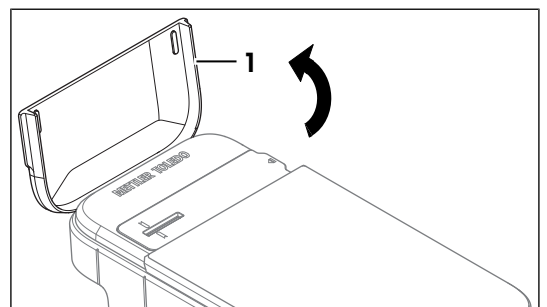

9 Grab the slide filled with the sample via the handle and insert it into the slot on the slide adapter with the correct orientation. Ensure that the black line on the slide is aligned with the alignment mark (1) on the adapter.

- ➔ The measurement starts immediately.
- ➔ A graphical status display appears on the screen indicating the progress of ongoing measurement. The total analysis time is approximately 15 seconds.

➔ Once the analysis is over, the measurement status is displayed on the screen.

10 Remove the slide (1) from the adapter.

- ➔ A result overview is displayed on the screen.

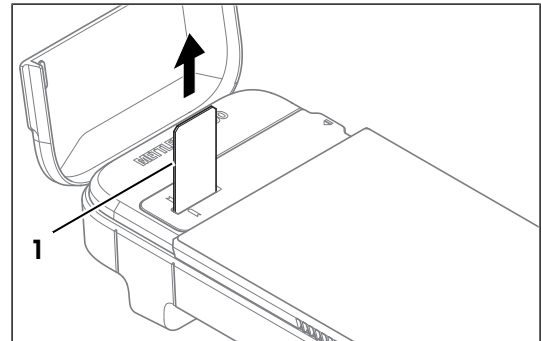
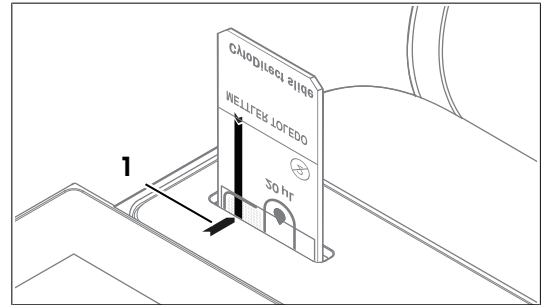

5.3 Results

5.3.1 Results overview

The result overview includes:

- Overall status of the measurement
- Total number of cells/mL
- Cell viability in % (VIA only)
- Number of live cells/mL (VIA only)
- Number of dead cells/mL (VIA only)
- Histogram showing size distribution of the cells
- Parameters
- Metadata

- 1 Tap (1) to view the reconstructed sample image.
 - ➔ The microscopic image is displayed on the screen.

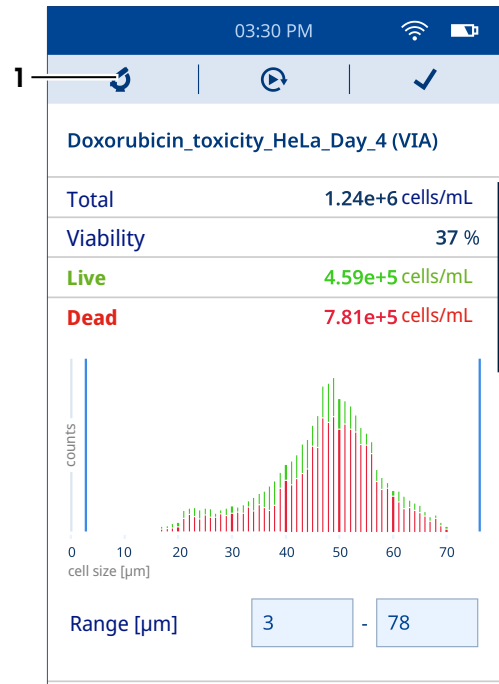

- 2 Tap (1) to adjust the range of desired cell size.
 - ➔ The counted cells are shown in boxes, where the green box represents live cells and the red one shows dead cells.
 - ➔ It is possible to zoom in and zoom out of the image with pinch-in and pinch-out gestures, respectively.
 - ➔ A double-tap gesture can bring the image back to its original size.

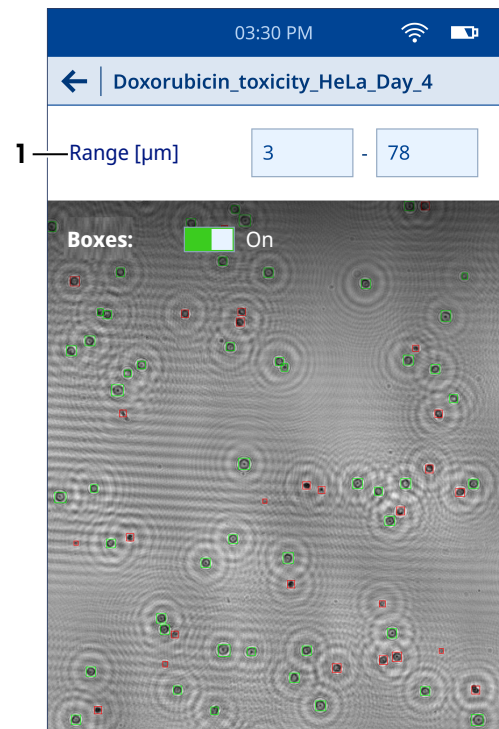

- 3 Tap (1) to start another measurement using similar method parameters.
 - ➔ A new measurement starts on the instrument.
- 4 Tap (2) to confirm the end of analysis.
 - ➔ The home screen opens.

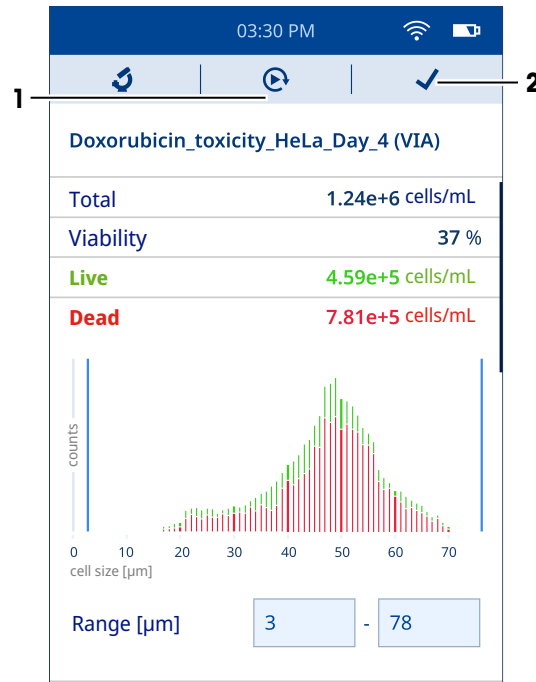

5.3.2 View results

- The home screen is open.
- 1 Select icon.
 - ➔ A list of stored results is displayed.
 - 2 To view the details of an individual result, navigate to the result and select it.

In addition, you can use the filters for viewing a particular set of results that you are interested in. The results can be filtered based on application type (VIA, CC or both) and date range.
 - 3 Select icon.
 - ➔ A **Filter Results** screen opens.
 - 4 Select the desired filter (single or multiple).
 - 5 If you select **Date Range**, define the values for start date and end date.
 - 6 Tap **Show Results**.
 - ➔ A list of results based on the selected filters is displayed on the screen.

5.3.3 Export results

The results stored in the instrument can be directly exported to the computer. For network requirements, see [Network requirements ▶ Page 15].

Procedure

- The instrument and computer are connected to the same network.
 - The home screen is open.
- 1 Go to **Settings** > **Data Transfer**.
 - 2 Select **Set Up Connection**.
 - 3 Open the browser on the computer.
 - 4 Enter the IP address displayed on the instrument screen in the search bar of the browser.
- ➔ A list of results stored in the instrument is displayed on the computer screen.

Export an individual result or a subset of results

- A list of stored results is displayed on the computer screen.
- 1 Navigate to the result you want to download.

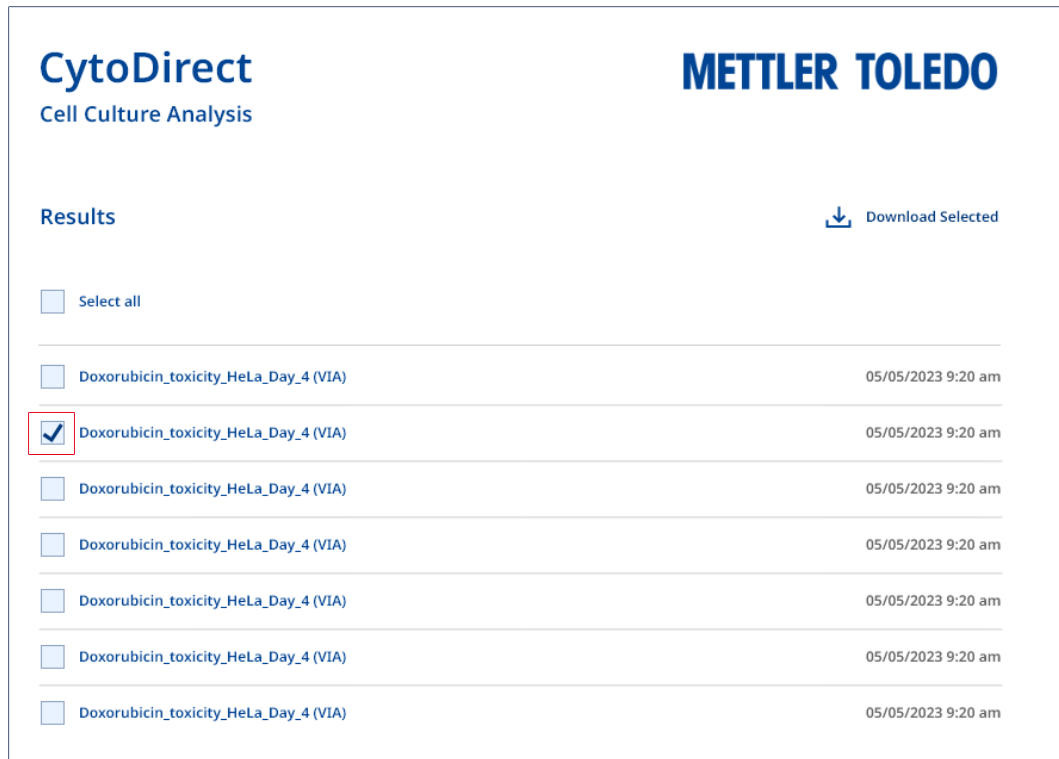

The screenshot shows the CytoDirect interface with the METTLER TOLEDO logo. Under the 'Results' section, there is a 'Download Selected' button with a download icon. Below this is a 'Select all' checkbox. A list of eight results is shown, each with a checkbox on the left and a timestamp on the right. The second result, 'Doxorubicin_toxicity_HeLa_Day_4 (VIA)' with a timestamp of '05/05/2023 9:20 am', has its checkbox checked and is highlighted with a red box.

Results	Download Selected
<input type="checkbox"/> Select all	
<input type="checkbox"/> Doxorubicin_toxicity_HeLa_Day_4 (VIA) 05/05/2023 9:20 am	
<input checked="" type="checkbox"/> Doxorubicin_toxicity_HeLa_Day_4 (VIA) 05/05/2023 9:20 am	
<input type="checkbox"/> Doxorubicin_toxicity_HeLa_Day_4 (VIA) 05/05/2023 9:20 am	
<input type="checkbox"/> Doxorubicin_toxicity_HeLa_Day_4 (VIA) 05/05/2023 9:20 am	
<input type="checkbox"/> Doxorubicin_toxicity_HeLa_Day_4 (VIA) 05/05/2023 9:20 am	
<input type="checkbox"/> Doxorubicin_toxicity_HeLa_Day_4 (VIA) 05/05/2023 9:20 am	
<input type="checkbox"/> Doxorubicin_toxicity_HeLa_Day_4 (VIA) 05/05/2023 9:20 am	

- 2 Select the square that appears on the LHS of the desired result (single or multiple).

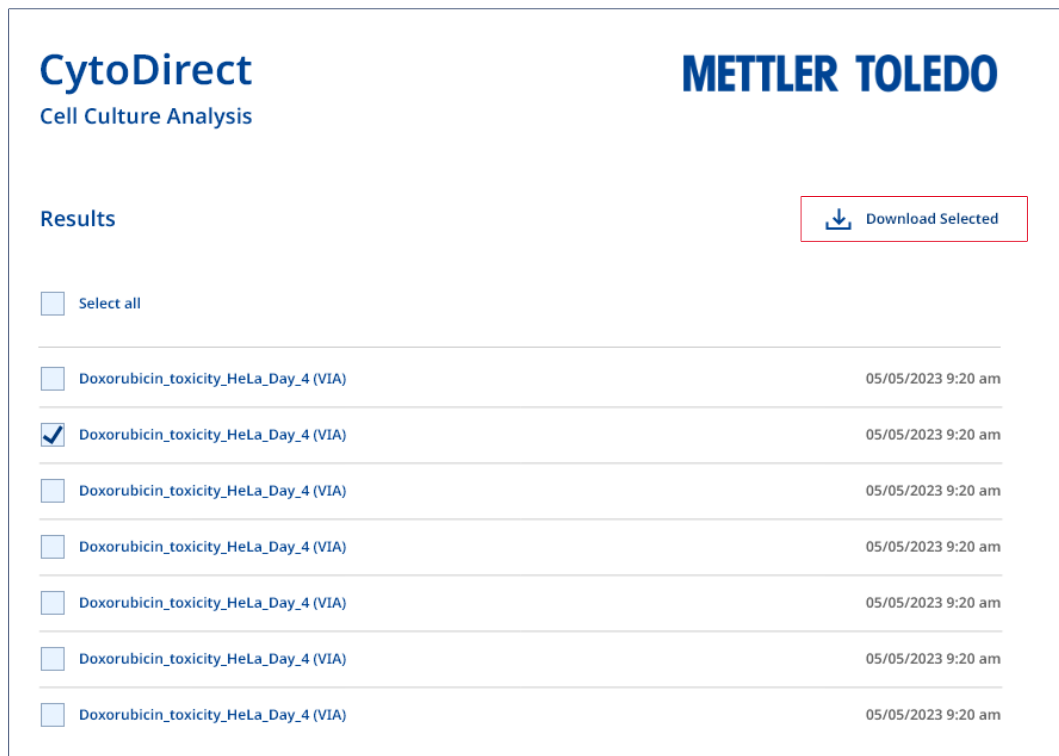

The screenshot shows the same CytoDirect interface as above. In this view, the 'Download Selected' button is highlighted with a red box. The second result in the list, 'Doxorubicin_toxicity_HeLa_Day_4 (VIA)' with a timestamp of '05/05/2023 9:20 am', has its checkbox checked.

Results	Download Selected
<input type="checkbox"/> Select all	
<input type="checkbox"/> Doxorubicin_toxicity_HeLa_Day_4 (VIA) 05/05/2023 9:20 am	
<input checked="" type="checkbox"/> Doxorubicin_toxicity_HeLa_Day_4 (VIA) 05/05/2023 9:20 am	
<input type="checkbox"/> Doxorubicin_toxicity_HeLa_Day_4 (VIA) 05/05/2023 9:20 am	
<input type="checkbox"/> Doxorubicin_toxicity_HeLa_Day_4 (VIA) 05/05/2023 9:20 am	
<input type="checkbox"/> Doxorubicin_toxicity_HeLa_Day_4 (VIA) 05/05/2023 9:20 am	
<input type="checkbox"/> Doxorubicin_toxicity_HeLa_Day_4 (VIA) 05/05/2023 9:20 am	
<input type="checkbox"/> Doxorubicin_toxicity_HeLa_Day_4 (VIA) 05/05/2023 9:20 am	

- 3 Click **Download Selected**.
- ➔ All files associated with the selected results are downloaded on the computer.

Export all results

- A list of stored results is displayed on the computer screen.

The screenshot shows the CytoDirect Cell Culture Analysis interface. At the top left is the logo 'CytoDirect Cell Culture Analysis' and at the top right is the 'METTLER TOLEDO' logo. Below the logos, there is a 'Results' section with a 'Download Selected' button (indicated by a download icon) on the right. A 'Select all' checkbox is highlighted with a red box. Below this, there is a list of results, each with a checkbox and a timestamp '05/05/2023 9:20 am'. The second item in the list has its checkbox checked.

- 1 Click **Select all**.
 - 2 Click **Download Selected**.
- ➔ All files associated with all results stored in the instrument are downloaded on the computer.

Export selected result details

- A list of stored results is displayed on the computer screen.
- 1 Navigate to the result you want to download.
 - 2 Select the result.
 - ➔ A list of all files associated with the selected result is displayed on the computer screen.

The screenshot shows the CytoDirect Cell Culture Analysis interface with the breadcrumb 'Results / Doxorubicin_toxicity_HeLa_Day_4'. The 'Download Selected' button is on the right. Below the breadcrumb, there is a list of result details, each with a checkbox. The 'Microscopic Image' checkbox is highlighted with a red box. Other options include 'Hologram', 'Excel Table', and 'PDF Report'.

- 3 Select the square that appears on the LHS of the desired result detail (single or multiple).

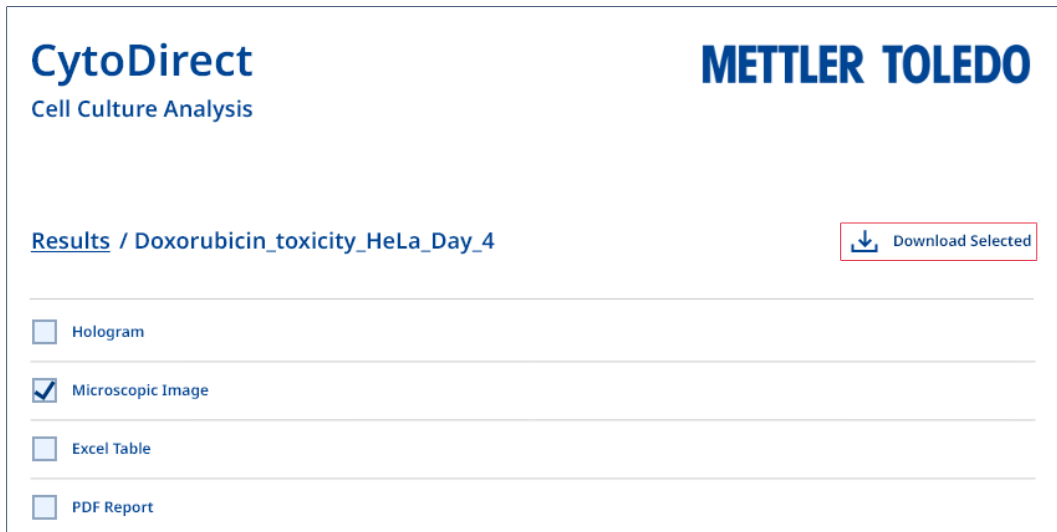

- 4 Click **Download Selected**.
 - ➔ The selected result details are downloaded on the computer.

See also

[Configure network connection](#) ▶ Page 13

5.3.4 Delete results

You can delete a single result or multiple results or all results.

- The home screen is open.
- 1 Select icon.
 - ➔ A list of stored results is displayed.
 - 2 Select the results that you want to delete (single or multiple or all).
 - 3 Select icon.
 - ➔ A selection menu appears on the screen.
 - 4 Select **Yes, Delete Results**.
 - ➔ The selected results are deleted from the list.

6 Maintenance

In this chapter you find descriptions of the maintenance tasks you should perform on your instrument. Any other maintenance tasks need to be performed by a service technician who has been qualified by METTLER TOLEDO.

If you experience problems with your instrument, contact your authorized METTLER TOLEDO service representative or dealer.

METTLER TOLEDO recommends that a preventive maintenance and calibration certification is done at least once a year through your authorized METTLER TOLEDO service representative or dealer.

▶ www.mt.com/contact

6.1 Maintenance schedule

Follow this maintenance schedule, unless otherwise required by the standard operating procedures of your company.

After each measurement series

Task	Link
Dipose of the slides	[Dispose of the instrument ▶ Page 31]

Every day

Task	Link
Export the data	[Export results ▶ Page 22]

Every week

Task	Link
Run the performance test	[Check the workflow accuracy ▶ Page 30]
Clean the housing	[Clean the housing ▶ Page 26]
Clean the slide adapter	[Clean the slide adapter ▶ Page 27]
Clean the slide adapter slot	[Clean the slide adapter slot ▶ Page 28]
Clean the sensor	[Clean the sensor ▶ Page 29]

Every month

Task	Link
Check for firmware updates	[Update the firmware ▶ Page 31]

Before periods of inactivity

Task	Link
Clean the housing	[Clean the housing ▶ Page 26]
Clean the slide adapter	[Clean the slide adapter ▶ Page 27]
Clean the slide adapter slot	[Clean the slide adapter slot ▶ Page 28]
Clean the sensor	[Clean the sensor ▶ Page 29]

6.2 Clean the instrument



NOTICE

Damage to the instrument due to inappropriate cleaning methods

Inappropriate cleaning methods can damage the housing or other parts of the instrument. If liquids enter the housing, they can damage the instrument.

- 1 Ensure the cleaning agent is compatible with the material of the part you want to clean.
- 2 Ensure that no liquid enters the interior of the instrument.
- 3 Do not use compressed air for drying purpose.

If you have questions about the compatibility of cleaning agents, contact your authorized METTLER TOLEDO service representative or dealer.

▶ www.mt.com/contact

See also

🔗 Technical data ▶ Page 34

6.2.1 Clean the housing

METTLER TOLEDO recommends the following cleaning agents:

- Ethanol (70 %)
- Isopropanol (≤ 70 %)
- Sodium hypochlorite (≤ 0.625 %)
- Quaternary ammonium compounds in isopropyl alcohol (≤ 0.5 %)
- Phenolic disinfectant (0.05 %)

Some of the recommended cleaning agents are hazardous materials. Wear protective gear as required by the safety-data sheets of the cleaning agents you use and the safety rules of your workplace.

Procedure

- The instrument is shut down.
- 1 Wipe the housing with a lint-free tissue moistened with the cleaning agent.
- 2 Air-dry the housing or dry it with a soft tissue.

See also

 Technical data ▶ Page 34

6.2.2 Clean the slide adapter

METTLER TOLEDO recommends the following cleaning agents:

- Ethanol (70 %)
- Isopropanol (≤ 70 %)
- Sodium hypochlorite (≤ 0.625 %)
- Quaternary ammonium compounds in isopropyl alcohol (≤ 0.5 %)
- Phenolic disinfectant (0.05 %)

Some of the recommended cleaning agents are hazardous materials. Wear protective gear as required by the safety-data sheets of the cleaning agents you use and the safety rules of your workplace.

Procedure

- The instrument is shut down.
- 1 Open the instrument lid (1).

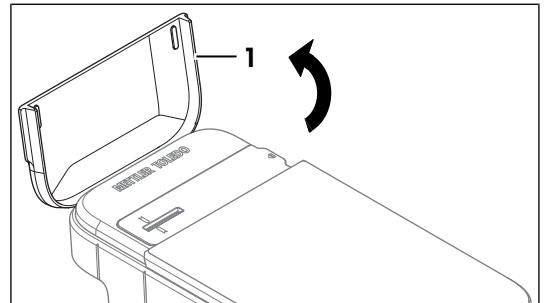

- 2 Remove the slide adapter (1) by gently lifting it from the side (2).
- 3 Wipe the slide adapter with a lint-free tissue moistened with the cleaning agent.
- 4 Air-dry the slide adapter or dry it with a soft tissue.

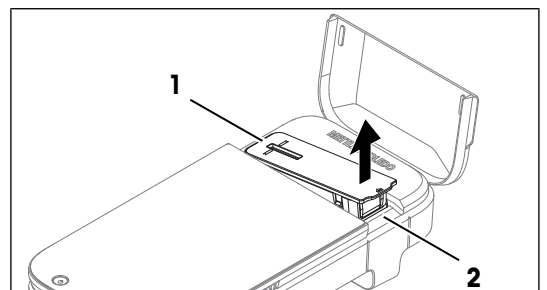

- 5 Put the slide adapter back to its original position on the instrument.
- 6 Close the instrument lid.

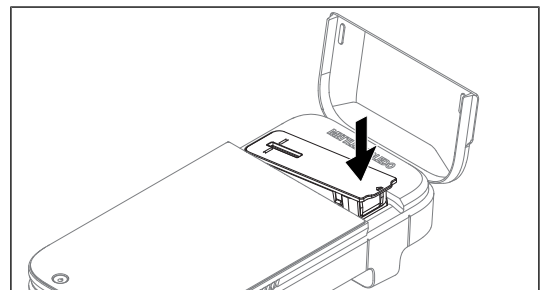

See also

[Technical data](#) ▶ Page 34

6.2.3 Clean the slide adapter slot

METTLER TOLEDO recommends the following cleaning agents:

- Ethanol (70 %)
- Isopropanol (≤ 70 %)
- Sodium hypochlorite (≤ 0.625 %)
- Quaternary ammonium compounds in isopropyl alcohol (≤ 0.5 %)
- Phenolic disinfectant (0.05 %)

Some of the recommended cleaning agents are hazardous materials. Wear protective gear as required by the safety-data sheets of the cleaning agents you use and the safety rules of your workplace.

Procedure

- The instrument is shut down.

1 Open the instrument lid (1).

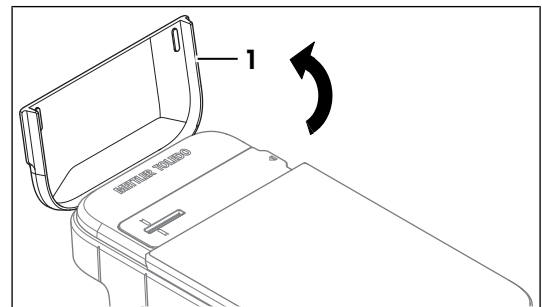

2 Remove the slide adapter (1) by gently lifting it from the side (2).

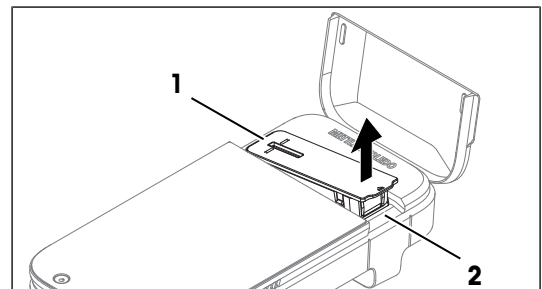

3 Turn the instrument over so that the opening of the slide adapter slot is facing down.

4 Tap the back of the instrument (1) gently to make the loose particles fall out, if any.

5 Return the instrument to its upright position.

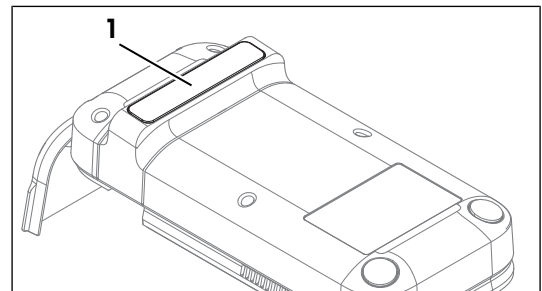

6 Wipe the surface of the slide adapter slot (1) with a lint-free tissue moistened with the cleaning agent.

7 Air-dry the slide adapter slot or dry it with a soft tissue.

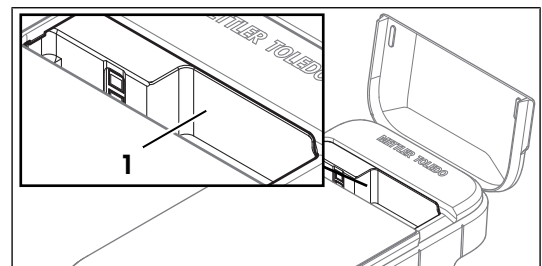

- 8 Put the slide adapter back to its original position on the instrument.
- 9 Close the instrument lid.

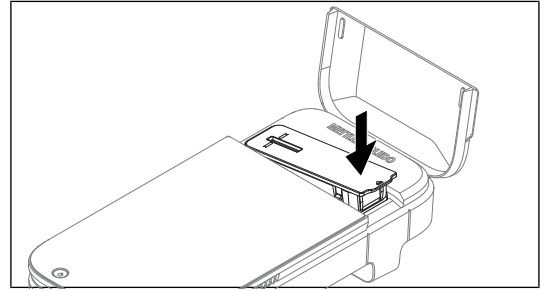

See also

[Technical data](#) ▶ Page 34

6.2.4 Clean the sensor

METTLER TOLEDO recommends the following cleaning agents:

- Ethanol (99 %)
- Isopropanol (99 %)

Some of the recommended cleaning agents are hazardous materials. Wear protective gear as required by the safety-data sheets of the cleaning agents you use and the safety rules of your workplace.

Procedure

- The instrument is shut down.
- 1 Open the instrument lid (1).

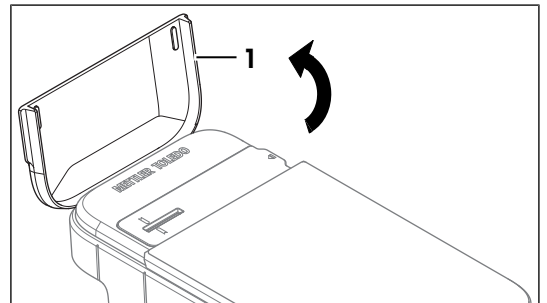

- 2 Remove the slide adapter (1) by gently lifting it from the side (2).

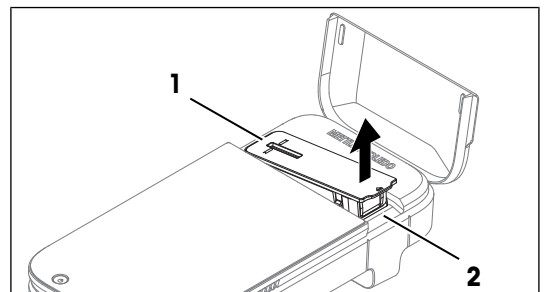

- 3 Clean the sensor surface (1) by gently moving the cleaning swab moistened with the cleaning agent back and forth.
- 4 Dispose the cleaning swabs after use.
- 5 Air-dry the sensor surface.

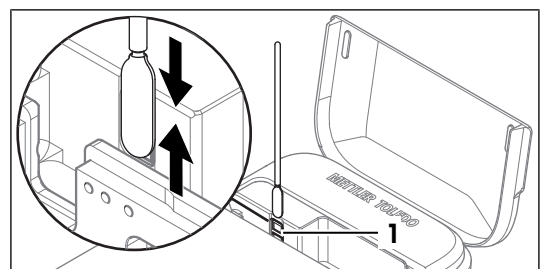

- 6 Put the slide adapter back to its original position on the instrument.
- 7 Close the instrument lid.

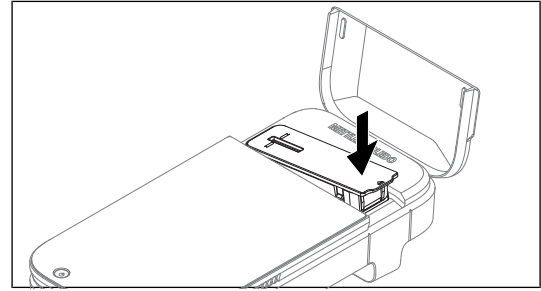

See also

[🔗 Technical data](#) ▶ Page 34

6.3 Check the workflow accuracy

To check the measurement accuracy of the instrument including sample preparation workflow in terms of cell counting, you need to configure and perform a test using the Performance Verification Kit (PVK). This kit contains bead suspension of certified concentration.

6.3.1 Configure the test

- The home screen is open.

 - 1 Go to **Settings** > **Performance Tests**.
 - 2 Select **Add a new PVK**.
 - 3 Define the parameters as explained below.

Parameter	Explanation	Values
PVK Lot number	Defines the lot number of PVK, which can be found on the CytoDirect test beads tube.	Character (11 to 15)
Reference Concentration [beads/mL]	Defines the certified concentration of test beads, which can be found on the CytoDirect test beads certificate.	Character, Integer, Symbol
Tolerance	The result is marked as passed if it falls within the following range. Target Concentration ± Tolerance For best results, the tolerance value of 10 % is recommended.	Integer (1 to 100)
Expiry Date	Defines the expiry date of PVK, which can be found on the CytoDirect test beads certificate.	MM YYYY

- 4 Tap **Save PVK Data**.
 - ➔ The name of newly added PVK is displayed in the available PVK list.

6.3.2 Perform the test

- The home screen is open.

 - 1 Go to **Settings** > **Performance Tests**.
 - 2 Select **Start Performance Test Measurement**.
 - 3 Select the desired PVK from the list. If you are using a new PVK, add the information using the option **Add a new PVK**. See [Configure the test ▶ Page 30]
 - 4 Perform the measurement. See [Perform a measurement ▶ Page 18]
 - ➔ The performance test result is displayed on the screen, at the end of the measurement.
 - ➔ The result is also displayed in the list of **View Previous Measurements**.

6.4 Update the firmware

The firmware of the instrument can be updated. The process takes up to 20 minutes. For network requirements, see [Network requirements ▶ Page 15].

Procedure

- The home screen is open.
- 1 Go to **Settings** > **Updates**.
- 2 Select **Install Update**.
- ➔ The firmware updates will be installed.
- ➔ The instrument automatically restarts once the installation is complete.

6.5 Prepare the instrument for storage

The instrument can be stored at temperatures of -10 °C to 50 °C. However, the lifespan of the battery is reduced when it is stored at temperatures above 40 °C for more than three months.

- 1 Shut down the instrument.
- 2 Disconnect any accessories from the instrument.
- 3 Close the instrument lid.
- 4 Clean the instrument.
- 5 Store the instrument in a dry and clean place.

See also

- 🔗 Start up and shut down the instrument ▶ Page 12
- 🔗 Clean the instrument ▶ Page 26
- 🔗 Technical data ▶ Page 34

6.6 Dispose of the instrument

Dispose of the slide

- 1 Remove the slide after use.
- 2 Dispose of the slide according to the laboratory guidelines of your workplace.

Dispose of the instrument

In conformance with the European Directive 2012/19/EU on Waste Electrical and Electronic Equipment (WEEE) this device may not be disposed of in domestic waste. This also applies to countries outside the EU, per their specific requirements.

Please dispose of this product in accordance with local regulations at the collecting point specified for electrical and electronic equipment. If you have any questions, please contact the responsible authority or the distributor from which you purchased this device. Should this device be passed on to other parties, the content of this regulation must also be related.



7 Troubleshooting

7.1 List of errors and problems

Problem	Possible cause	Measure
The instrument does not switch on.	The battery is empty.	See [Charge the instrument ▶ Page 11]
	The firmware has crashed.	<ol style="list-style-type: none"> 1 Switch off the instrument with the hard shut down method. See [Start up and shut down the instrument ▶ Page 13] 2 Switch on the instrument. See [Start up and shut down the instrument ▶ Page 12]
	The instrument is overheated.	<ol style="list-style-type: none"> 1 Ensure that the instrument is not exposed to direct sunlight. 2 Keep the instrument in a cool and shady place for 15 minutes. 3 Switch on the instrument. See [Start up and shut down the instrument ▶ Page 12]
An air bubble is detected by the firmware.	The small air bubbles from the sample are transferred on the slide while pipetting.	<ol style="list-style-type: none"> 1 Take extra caution when mixing the sample. 2 Ensure that no air bubbles are transferred to the slide while pipetting the sample.
	The slide is not completely filled.	<ol style="list-style-type: none"> 1 Increase the sample volume from 20 µL up to 22 µL. 2 Take extra caution not to overfill the slide.
A result is flagged as Uncertain even though the sample concentration is less than 10 ⁷ cells/mL.	The average diameter of the sample cells is greater than 10 µm.	<ul style="list-style-type: none"> ■ Although cells with smaller diameters (< 10 µm) can be counted at concentrations approaching 10⁷ cells/mL, bigger cells occupy more surface on the sensor and subsequently can only be measured at lower concentrations. <ol style="list-style-type: none"> 1 Dilute the sample at least 10 times. 2 Perform the measurement again.
The screen does not respond to touch.	The gloves used are not clean.	– Use clean gloves.
	The screen is not clean.	See [Clean the housing ▶ Page 26]
	The firmware has crashed.	<ol style="list-style-type: none"> 1 Switch off the instrument with the hard shut down method. See [Start up and shut down the instrument ▶ Page 13] 2 Switch on the instrument. See [Start up and shut down the instrument ▶ Page 12]

Problem	Possible cause	Measure
The instrument response is slow.	The instrument has an older version of firmware.	See [Update the firmware ▶ Page 31]
	The data storage memory of instrument is almost full.	1 Export the results. See [Export results ▶ Page 22] 2 Delete the results. See [Delete results ▶ Page 25]
	The firmware has crashed.	1 Switch off the instrument with the hard shut down method. See [Start up and shut down the instrument ▶ Page 13] 2 Switch on the instrument. See [Start up and shut down the instrument ▶ Page 12]
The instrument cannot perform an update.	The instrument is not connected to the network.	See [Configure network connection ▶ Page 13]
	The battery is running low.	– Charge the instrument to over 50 % capacity. See [Charge the instrument ▶ Page 11]
	The date and time are not correctly set in the instrument.	See [Configure date and time ▶ Page 14]
The automated sensor check keeps failing after cleaning the sensors with the cleaning swabs.	The recommended cleaning procedure is not followed.	See [Clean the sensor ▶ Page 29]
	The sensor is damaged.	Contact your authorized METTLER TOLEDO service representative or dealer for technical support.

7.2 View the firmware version and other system information

Firmware version and other system information can be accessed in the system settings. Parameters that can be viewed include:

- Instrument serial number
- Instrument firmware version
- Manufacturer information
- Licensing information

Procedure

- The home screen is open.
- 1 Go to **Settings** > **System and Maintenance**.
 - 2 Select **System Information**.
- ➔ The firmware version and other system information are displayed on the screen.

8 Technical data

8.1 Instrument

Power supply

Characteristic		Value
Instrument	Input rating	5 V DC, 3 A
	Power consumption	15 W
	Socket	USB Type C
AC/DC adapter	Input rating	100...240 V AC, 0.5 A
	Fluctuation of supply line voltage	±10 %
	Input frequency	47...63 Hz
	Output rating	5 V DC, 3 A

Instrument

Characteristic		Value
Dimensions	Width	128 mm
	Depth	260 mm
	Height	60 mm
Weight		1 110 g
Display	Technology	Color display with capacitive multitouch screen
	Size	7 "
	Resolution	480 x 272 pixel
Battery	Type	Rechargeable lithium-ion battery
	Capacity	3300 mAh
	Temperature range for charging	10...45 °C
Connectivity		Wi-Fi (WLAN WPA2-EAP), Ethernet 10/100 MB, USB-C, NFC
Firmware update		OTA
Materials	Housing	ABS Polylac PA-765
	Frame top	2-layer-lacquering Mankiewicz Alexit cover lacque 461-24 in Pantone 10104C, VDI 3400 Ref.24
	Lid	ABS Polylac PA-765
	Screen	Glass

Site requirements

Characteristic		Value
Ambient conditions	Ambient temperature	15...30 °C
	Recommended ambient temperature for operation	Room temperature (20...22 °C)
	Relative humidity	30...70 % (Non-condensing)
	Altitude	< 5000 m above sea level
	Use	Indoor
	Overvoltage category	I
	Pollution degree	2

Characteristic	Value	
Storage conditions	Temperature	-10...50 °C
	Relative humidity	10...90 % (Non-condensing)

8.2 Slide

Characteristic	Value	
Dimensions	Width	26 mm
	Depth	76 mm
	Height	1 mm
Weight	5 g	
Materials	Slide	Soda-lime glass
	Cover	Borosilicate glass
Ambient conditions	Temperature	15...30 °C
	Relative humidity	30...70 % (Non-condensing)
Storage conditions	Temperature	15...30 °C
	Relative humidity	30...70 % (Non-condensing)

8.3 Measurement

Characteristic	Value	
Acquisition technology	Digital Holographic Microscopy	
Detection Method	Pre-trained Machine Learning	
Working range	10 ⁴ ...10 ⁷ cells/mL	
Cell size	2...80 µm	
Staining	None	
Measurement time	< 15 seconds	
Light source	Type	laser diode
	Wavelength	approx. 405 nm
Number of sensors	2	
Field of view	Area	4.6 x 3.4 mm ² per sensor
Sensor	Pixel size	1.1 µm x 1.1 µm
	Image size	≥ 4200 x 3100 pixels
Sample	Min. volume	20 µL
	Min. no. of stored results	100

9 Accessories, spare parts and consumables

The following accessories, spare parts and consumables are available for the automated cell counter. All accessories, spare parts and consumables are specified with their order number.

If you have any questions, contact your authorized METTLER TOLEDO service representative or dealer.

► www.mt.com/contact

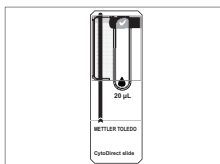

Slide (25 pcs)
20µL

30937102

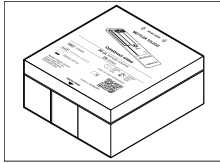

Slide box (10 pcs)

30937103

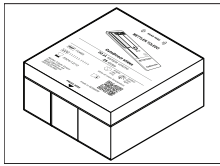

Slide box (20 pcs)

30937104

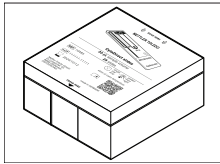

Slide box (50 pcs)

30937105

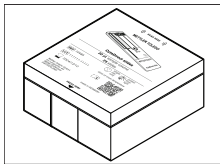

Slide box (100 pcs)

30937106

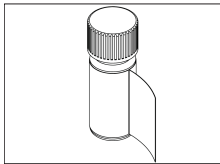

Performance verification kit

30937107

To protect your product's future:

METTLER TOLEDO Service assures the quality, measuring accuracy and preservation of value of this product for years to come.

Please request full details about our attractive terms of service.

► www.mt.com/service

www.mt.com/CytoDirect

For more information

Mettler-Toledo GmbH

Im Langacher 44
8606 Greifensee, Switzerland
www.mt.com/contact

Subject to technical changes.
© 04/2024 METTLER TOLEDO. All rights reserved.
30962829A



30962829