

Product Monitoring and Identification Systems for Food & Beverage Applications



How it Works

The RAMS (Reflection – Absorption – Multi – Switch) measures reflection and absorption of the process medium in the pipe at 4 wavelengths (blue, green, red, near-infrared). The measurement of both Turbidity and Color is possible.



Easy Installation

The RAMS fitted into the product pipe with a standard VARINLINE™ housing. The housings ensures both easy installation of the sensor and optimal cleaning characteristics for CIP/SIP processes.



Configuration Software

For the types BASIC, CALI and COMBINE a software package is available optionally for identification of new products, for FTU/EBC calibration, for simple presentation, saving of readings and for parameterization.



Factory Calibrated

Each sensor is delivered factory calibrated based on a multipoint calibration. That means: No calibration on site necessary.



InPro 8300 RAMS

The InPro 8300 RAMS turbidity system is designed for use in phase separation by turbidity/color and for product identification applications. The InPro 8300 RAMS systems are rugged and easy-to-use devices, with low maintenance and easy configuration.

InPro 8300 RAMS systems are widely used in brewery applications for beer/water separation, product identification before filler line and separator control. For the product identification a fingerprint of the product in question is taken and stored in the InPro 8300 RAMS. This measurement is done by one or more parameters (p. ex. blue and green transmission or turbidity and IR absorption). These "fingerprints" can be stored for up to 8 products.

Technical data of the InPro 8300 RAMS series

Measuring cycle (all 8 parameters)	approx. 5 measurements per second
Span	400 ... 2000 RAMS units
Repeatability	± 1 % of measuring range
Power supply	24 V DC ± 5 %
Power consumption	< 50 mA plus total of output currents, polarity reversal protection up to 30 V
Parameter setting interface	RS-232
Operating conditions	
Ambient temperature	0 ... 40 °C
Product temperature	0 ... 105 °C (140 °C as an option)
Temperature compensation	0 ... 50 °C in steps of 0.1 °C > 50 °C in steps of 0.5 °C
Rel. humidity	0 ... 100 %
Protection class	IP 67
Storage temperature	-40 ... + 125 °C
Temperature measurement (in the electronics)	
Measuring range	-40 ... + 120 °C
Accuracy tolerance	max. ± 3 °C absolute
Humidity measurement (in the electronics)	
Measuring range	0 ... 100 %
Accuracy tolerance	max. ± 2.5 % absolute
Materials	
Optics housing	1.4404
Seals	EPDM
Viewing window	PVC
Cable glands	brass / nickel plated
Connecting cable	Ölflex, 4 × 0.75 mm ²

Measuring Cell

Housing material	1.4404
Sealing material	EPDM, alternatively FKM
Glass quality	Borosilicate
Option:	Sapphire (only in connection with OPL bits)
Operating pressure	max. 10 bar
Product temperature	-5 ... + 180 °C (depending on the sealing material)

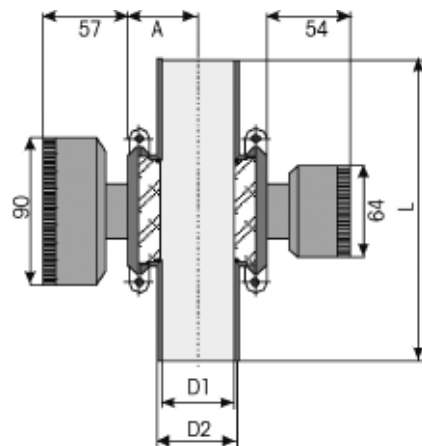

Dimensions

DN	D1	D2	L	A
40	38	42	180	37
50	50	54	180	44
65	66	70	250	52
80	81	85	250	60
100	100	104	250	69
125	125	129	250	82

O.D	D1	D2	L	A
1"	22.2	25.4	90	60
1 1/2"	34.9	38.1	90	73
2"	47.6	50.8	90	85.5
2 1/2"	60.3	63.5	125	98
3"	73	76.2	125	111
4"	97.4	101.6	125	135.5

I.P.S.	D1	D2	L	A
2"	56.3	60.3	114.3	95
3"	84.3	88.9	152.4	123
4"	109.7	114.3	152.4	148
6"	162.7	168.3	152.4	200

all sizes in mm

www.mt.com/pro

Visit for more information

Sales and service:



Management System
certified according to
ISO 9001 / ISO 14001

Mettler-Toledo AG

Process Analytics
CH - 8902 Urdorf, Switzerland
Phone +41 44 729 62 11
Fax +41 44 729 66 36

Subject to technical changes.
© 04 / 2009 Mettler-Toledo AG.
Printed in Switzerland. 52 801 152