

Track Particles in Real Time Optimize and Monitor Processes

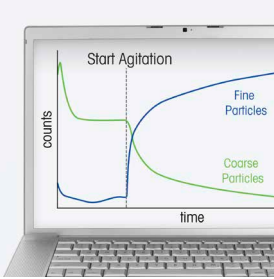

Measure Particle Size and Count

Particle size and count directly impact performance in multiphase processes including crystallization, emulsification and flocculation. By monitoring particle size and count in real time scientists can understand, optimize and scale-up processes confidently using evidence-based methods.



Understand without Sampling

Particles can change when sampled and prepared for offline analysis. By tracking changes to size and count, as particles naturally exist in process, scientists obtain process understanding safely and with no time delay – even at extremes of temperature and pressure.



Deliver Optimized Processes

By monitoring particles continuously, as experimental parameters vary, it is possible to conclusively determine optimized operating conditions. Evidence obtained in the laboratory, and the plant, can be used to ensure fit-for-purpose particles are delivered through high-quality processes.



Deploy in the Lab or Plant

A flexible mounting system allows probes to be installed in lab reactors, production vessels or pipelines using standard fittings and flanges. A robust probe design ensures continuous and reliable operation with minimal maintenance required.



ParticleTrack™ G600B

ParticleTrack G600B with FBRM® technology is a versatile probe-based instrument that is inserted directly into laboratory reactors and certain production processes to track changing particle size and count in real time at full process concentrations. Particles, particle structures and droplets are monitored continuously, as experimental conditions vary, providing scientists with the evidence required to deliver consistent particles with the required attributes.

Track Particles in Real Time

Optimize and Monitor Processes

Technical Data

Method of Measurement	Focused Beam Reflectance Measurement (FBRM)
Measurement Range	0.5 μm to 2000 μm
Probe Wetted Materials	C22; Sapphire window with Kalrez® 6375 O-rings
Probe Temp Range	-10 °C to 120 °C
Probe Pressure Range	10 barg
Probe Conduit Length	15 m [49.2 ft]
Probe Air Supply Requirements (Min)	Pressure: 4 barg [60 psig] Flow: 28.3 SLPM (1.0 SCFM)
Base Unit Temp Range	0 °C to 45 °C
Base Unit Description	Stainless 316, 4X, IP66
Power	100–240VAC, 50/60 Hz, 0.5 A
Certification	CE/NRTL Approved, Class 1 Laser Device, Compliant with 21CFR1040.10 and 1040.11 and IEC 60825-1; 4X

ParticleTrack G600B is not rated for explosive locations.

Base Unit Dimensions

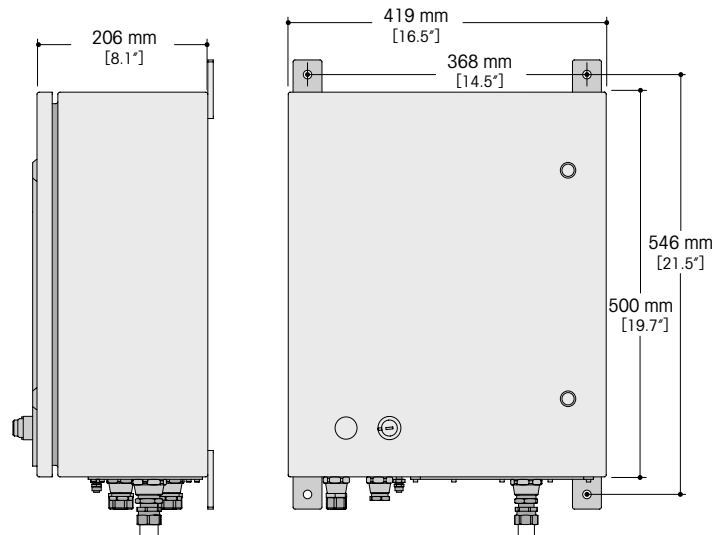

G600B Probe Dimensions

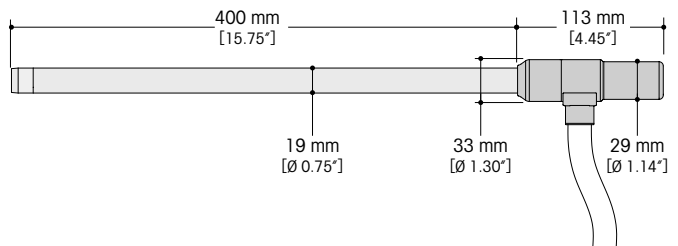

Mettler-Toledo AutoChem, Inc.

7075 Samuel Morse Drive
Columbia, MD 21046
Phone +1 410 910 8500
Fax +1 410 910 8600

Subject to technical changes
© 3/2017 Mettler-Toledo AutoChem, Inc
Printed in USA

www.mt.com/ParticleTrackG600B

For more information