

Easy System Integration Platform Size 600x600 mm



Floor Scale, Tank Weighing

MT1260 provides the best weighing performance for floor scales and hopper weighing in its capacity range. With a low profile design, cost optimization and an attractive product appearance can be achieved.



Off-Center Compensation

One load cell can be used to support a weighing platform and, due to the off-center load compensation, the MT1260 will weigh within tolerance regardless of load application point.



Robustness

MT1260 allows 50% static overload without compromising the weighing performance. The passivated aluminium provides good corrosion resistance suitable for many industrial applications.

MT1260 Single Point Load Cell

The MT1260 load cell features:

- OIML R60 C3 approval
- NTEP 5000 III S/M approval
- ATEX Zone 1/2 and 21/22 approvals
- Off-center load compensation (R76)
- 600x600 mm platform size
- IP67 protection class
- Passivated aluminum
- 50-750kg capacity range

The MT1260 is the ideal solution for floor scales and smaller hoppers. Due to the low profile the integration into any system is easy. The broad capacity range and large platform size allows wide usage in industrial weighing applications.

MT1260 Load Cell Specifications

Parameter	Unit of measure	Specification										
Model No.		MT1260										
Rated capacity (R.C.)	kg (lb, nominal)	50 (110)	75 (165)	100 (220)	150 (331)	200 (441)	250 (551)	300 (661)	500 (1102)	750 (1654)		
Rated output	mV/V @R.C.	2 ± 0.2										
Zero load output	%R.C.	≤ 10										
Combined error ¹⁾²⁾	%R.C.	≤ 0.016										
Repeatability error	%A.L. ³⁾	≤ 0.01										
Creep, 30 minute	%A.L.	≤ 0.0167										
Min. dead load output return (DR), 30 min	%A.L.	≤ 0.0167										
Temperature effect on	Min. dead load Output	%R.C./°C (./°F) ≤ 0.0014 (0.0008)										
	Sensitivity ²⁾	%A.L./°C (./°F) ≤ 0.0007 (0.00036)										
Temperature range	Compensated	-10 ~ +40 (+14 ~ +104)										
	Operating	°C (°F) -40 ~ +65 (-40 ~ +150)										
	Safe storage	-40 ~ +80 (-40 ~ +176)										
OIML / European approval ⁴⁾	OIML Cert. No.	R60/2000-NL1-03.14										
	European Cert. No.	NMI TC5367										
	Class	C3										
	nmax	3000										
	Vmin	g	8.3	15	16.7	25	33.3	41.7	50	83	125	
	PLC		0.7									
	Humidity symbol		None									
	Min. dead load	kg (lb)	0 (0)									
	Z		3000									
	NTEP approval ⁴⁾	Number	11-088									
Class		III S, III M										
nmax		5000										
Vmin		g (lb)	5 (0.011)	7.5 (0.017)	10 (0.022)	15 (0.033)	20 (0.044)	25 (0.055)	30 (0.066)	50 (0.11)	70 (0.17)	
Min. dead load		kg (lb)	0 (0)									
ATEX approval ⁴⁾	Number, cat. 2	KEMA 09ATEX0003 X										
	Number, cat. 3	KEMA 09ATEX0004 X										
	Rating		II 2 G Ex ib IIC T4									
			II 2 D Ex ibD 21 IP66 T135 °C									
			II 3 G Ex nA II T4									
Entity parameters		II 3 G Ex nL IIC T4										
		II 3 D Ex tD A22 IP66 T135°C										
Excitation voltage	Recommended	Ui/Un=20V, li=600mA, Pi=1.25W, Ci=5nF, Li=30µH										
	Max.	V AC/DC	5 ~ 15									
Terminal resistance	Excitation	Ω	20									
	Output		410 ± 10									
Insulation resistance @50VDC	MΩ	350 ± 4										
Breakdown voltage	V AC	> 5000										
Material	Spring element		> 500									
	Enclosure		Aluminium									
	Cable		None									
Protection	Type		PVC									
	IP rating		Potted									
	NEMA rating		IP 67									
Load limit	Safe	%R.C.	NEMA 6/6P									
	Ultimate		150									
Safe dynamic load	%R.C.	300										
Fatigue life	cycles @R.C.	70										
Direction of loading		> 1000000										
Deflection @ R.C., nominal	mm (in)	Beam										
Weight, nominal	kg (lb)	0.3 (0.012)										
Cable length	m (ft)	1.9 (4.2)										
Barometric pressure effect on zero load output	kg/kPa (lb/in.Hg)	2 (6.6)										
Safe side load	%R.C.	None										
Overload protection			100									
	Grade		None									
Mounting screw	Size/thread	mm (in)	12.9									
	Engaged length	mm (in)	M8x1.25									
	Torque, nominal	N.m (ft-lb)	20 (0.79)									
Max. platter size	cm x cm (in x in)	25 (18)										
Off center load error, R76-1	%A.L./cm (./in)	60 x 60 (24 x 24)										
		0.0032 (0.008)										

¹⁾ Error due to the combined effect of non-linearity and hysteresis

²⁾ Typical values only. The sum of errors due to combined error and temperature effect on sensitivity comply with the requirements of OIML R60 and NIST HB44.

³⁾ A.L. = Applied Load

⁴⁾ See certificate for complete information.



MT1260 Load Cell Dimensional Drawings mm [inch]

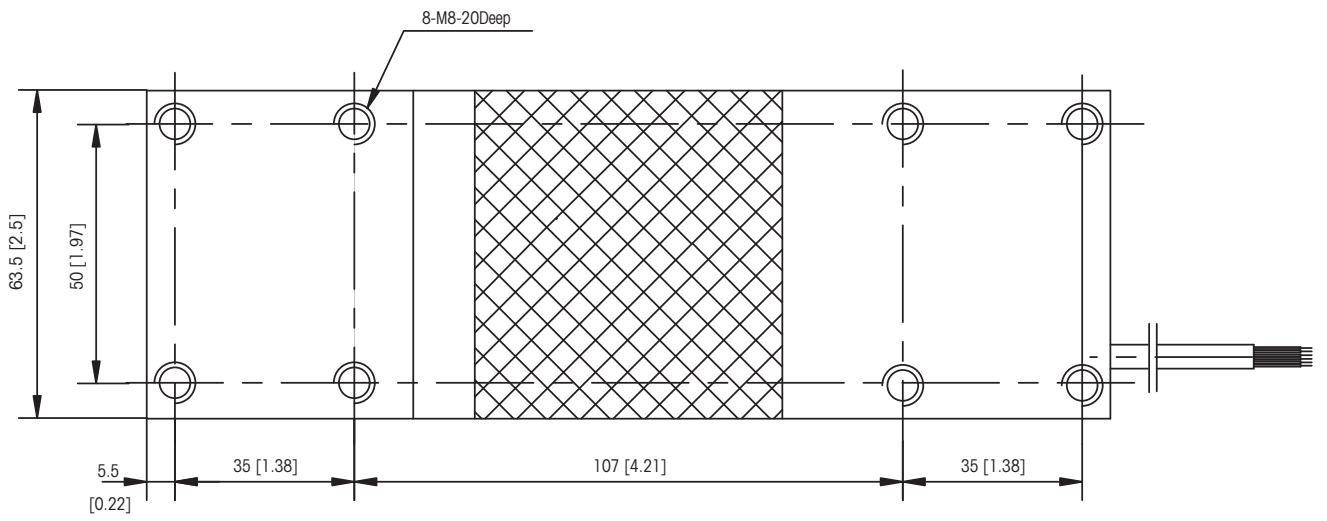
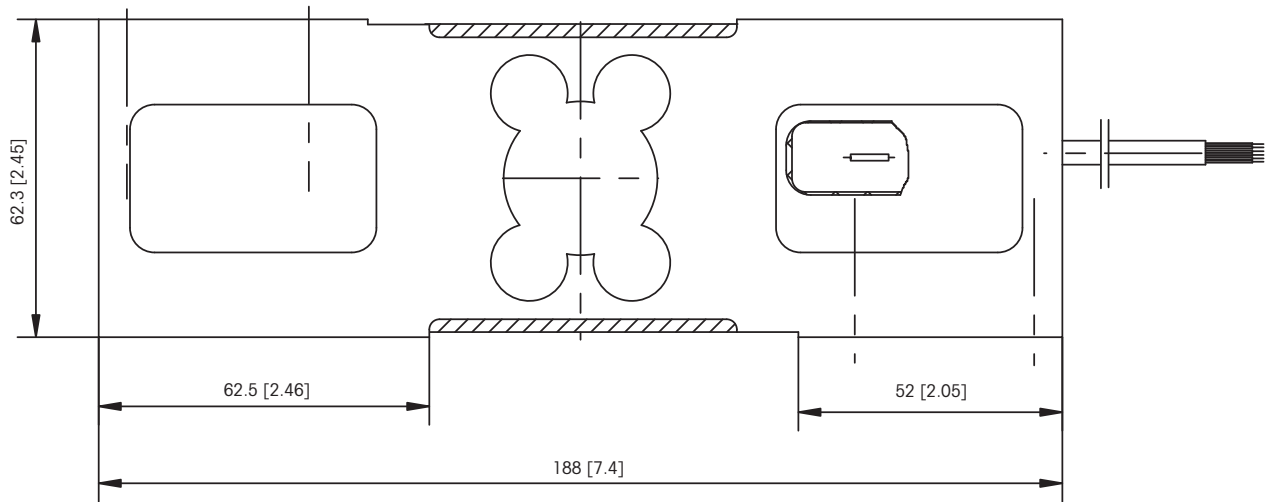

MT1260 Load Cell Order Information

Description		Item No.
Load cell, model no. MT1260-50kg	2m Cable	71201844
Load cell, model no. MT1260-75kg	2m Cable	71201845
Load cell, model no. MT1260-100kg	2m Cable	71201846
Load cell, model no. MT1260-150kg	2m Cable	71201847
Load cell, model no. MT1260-200kg	2m Cable	71201848
Load cell, model no. MT1260-250kg	2m Cable	71201849
Load cell, model no. MT1260-300kg	2m Cable	71207455
Load cell, model no. MT1260-500kg	2m Cable	71207456
Load cell, model no. MT1260-750kg	2m Cable	71209936
Load cell, model no. MT1260-50kg	6m Cable	72208484
Load cell, model no. MT1260-75kg	6m Cable	72208485
Load cell, model no. MT1260-100kg	6m Cable	72208486
Load cell, model no. MT1260-150kg	6m Cable	72208487
Load cell, model no. MT1260-200kg	6m Cable	72208488
Load cell, model no. MT1260-250kg	6m Cable	72208489
Load cell, model no. MT1260-300kg	6m Cable	72208490
Load cell, model no. MT1260-500kg	6m Cable	72208491
Load cell, model no. MT1260-750kg	6m Cable	72208492

Bolded entries are stocked

MT1260 Load Cell Cable Colours

Colour	Function
Green	+ Excitation
Black	- Excitation
Red	+ Signal
White	- Signal
Blue	+ Sense
Brown	- Sense
Yellow	+ Shield

Full Connectivity

METTLER TOLEDO supplies various data communication interfaces that enable our sensors and instruments to communicate with your PLC, MES, or ERP systems.



OIML Approvals

The MT1260 is provided with C3 approval acc. to OIML R60. Thus best weighing performance is guaranteed at all specified conditions. Benefit from METTLER TOLEDO experience.



METTLER TOLEDO Service

Our extensive service network is among the best in the world and ensures maximum availability and service life of your product.

Weighing Electronics

METTLER TOLEDO offers a complete family of electronics from simple weighing to application solutions for filling, stock control, batching, formulation, counting, and checkweighing.

METTLER TOLEDO Group

Industrial Division

Local contact: www.mt.com/contacts

Subject to technical changes

© 11/2019 METTLER TOLEDO. All rights reserved

Document No. 44099826 A

MarCom Industrial



www.mt.com

Visit for more information