

ACT350/ACT350 DIO/ACT350xx

Analog Type Transmitter



ACT350/ACT350 DIO/ACT350xx Analog Type Transmitter

METTLER TOLEDO Service

Essential Services for Dependable Performance of Your ACT350/ACT350 DIO/ACT350xx Analog Type Transmitter

Congratulations on choosing the quality and precision of METTLER TOLEDO. Proper use of your new equipment according to this Manual and regular calibration and maintenance by our factory-trained service team ensures dependable and accurate operation, protecting your investment. Contact us about a service agreement tailored to your needs and budget. Further information is available at www.mt.com/service.

There are several important ways to ensure you maximize the performance of your investment:

1. **Register your product:** We invite you to register your product at www.mt.com/productregistration so we can contact you about enhancements, updates and important notifications concerning your product.
2. **Contact METTLER TOLEDO for service:** The value of a measurement is proportional to its accuracy – an out of specification scale can diminish quality, reduce profits and increase liability. Timely service from METTLER TOLEDO will ensure accuracy and optimize uptime and equipment life.
 - a. **Installation, Configuration, Integration and Training:** Our service representatives are factory-trained, weighing equipment experts. We make certain that your weighing equipment is ready for production in a cost effective and timely fashion and that personnel are trained for success.
 - b. **Initial Calibration Documentation:** The installation environment and application requirements are unique for every industrial scale so performance must be tested and certified. Our calibration services and certificates document accuracy to ensure production quality and provide a quality system record of performance.
 - c. **Periodic Calibration Maintenance:** A Calibration Service Agreement provides on-going confidence in your weighing process and documentation of compliance with requirements. We offer a variety of service plans that are scheduled to meet your needs and designed to fit your budget.
 - d. **GWP® Verification:** A risk-based approach for managing weighing equipment allows for control and improvement of the entire measuring process, which ensures reproducible product quality and minimizes process costs. GWP (Good Weighing Practice), the science-based standard for efficient life-cycle management of weighing equipment, gives clear answers about how to specify, calibrate and ensure accuracy of weighing equipment, independent of make or brand.

© METTLER TOLEDO 2019

No part of this manual may be reproduced or transmitted in any form or by any means, electronic or mechanical, including photocopying and recording, for any purpose without the express written permission of METTLER TOLEDO.

U.S. Government Restricted Rights: This documentation is furnished with Restricted Rights.

Copyright 2019 METTLER TOLEDO. This documentation contains proprietary information of METTLER TOLEDO. It may not be copied in whole or in part without the express written consent of METTLER TOLEDO.

COPYRIGHT

METTLER TOLEDO® is a registered trademark of Mettler-Toledo, LLC. All other brand or product names are trademarks or registered trademarks of their respective companies.

METTLER TOLEDO RESERVES THE RIGHT TO MAKE REFINEMENTS OR CHANGES WITHOUT NOTICE.

FCC Notice

This device complies with Part 15 of the FCC Rules and the Radio Interference Requirements of the Canadian Department of Communications. Operation is subject to the following conditions: (1) this device may not cause harmful interference, and (2) this device must accept any interference received, including interference that may cause undesired operation.

This equipment has been tested and found to comply with the limits for a Class A digital device, pursuant to Part 15 of FCC Rules. These limits are designed to provide reasonable protection against harmful interference when the equipment is operated in a commercial environment. This equipment generates, uses, and can radiate radio frequency energy and, if not installed and used in accordance with the instruction manual, may cause harmful interference to radio communications. Operation of this equipment in a residential area is likely to cause harmful interference in which case the user will be required to correct the interference at his or her expense.

- Declaration of Conformity can be retrieved from ACT350 Download Page: www.mt.com/ind-act350-downlodas.

RoHS Compliance Statement.













- The majority of our products fall within categories 8 and 9. Those categories currently do not fall within the scope of the Directive 2002/95/EG (RoHS) of January 27, 2003. If our products are intended for use in other products which themselves fall within the scope of the RoHS Directive, compliance requirements have to be separately negotiated contractually.
- Those products which fall within categories 1-7 and 10 will be in compliance with the EU RoHS Directive from no later than July 1, 2006.
- If it is not possible for technical reasons to replace any non-RoHS-compliant substances in any of the above products as required, we plan to inform our customers in a timely manner









Statement regarding harmful substances

We do not make direct use of harmful materials such as asbestos, radioactive substances or arsenic compounds. However, we purchase components from third party suppliers, which may contain some of these substances in very small quantities.

Warnings and Cautions

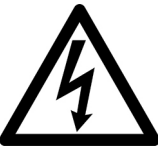
- READ this manual BEFORE operating or servicing this equipment and FOLLOW these instructions carefully.
- SAVE this manual for future reference.

	<p style="text-align: center;"> WARNING</p> <p>THE ACT350 IS INTENDED TO BE USED FOR PROCESS CONTROL AND IS NOT APPROVED AS A SAFETY COMPONENT. WHEN USED AS A COMPONENT PART OF A SYSTEM, ANY SAFETY CIRCUITS MUST BE INDEPENDENT OF THE ACT350 AND REMOVE POWER FROM THE ACT350 OUTPUTS IN THE EVENT OF AN EMERGENCY STOP OR EMERGENCY POWER DOWN.</p>
	<p style="text-align: center;"> WARNING</p> <p>ONLY USE RECOMMENDED 12-24 VDC POWER SUPPLY APPROVED AS NEC Class 2 OR RATED AS LIMITED POWER PER IEC60950-1.</p>
	<p>WHEN THIS EQUIPMENT IS INCLUDED AS A COMPONENT PART OF A SYSTEM, THE RESULTING DESIGN MUST BE REVIEWED BY QUALIFIED PERSONNEL WHO ARE FAMILIAR WITH THE CONSTRUCTION AND OPERATION OF ALL COMPONENTS IN THE SYSTEM AND THE POTENTIAL HAZARDS INVOLVED. FAILURE TO OBSERVE THIS PRECAUTION COULD RESULT IN BODILY HARM AND/OR PROPERTY DAMAGE.</p>
	<p style="text-align: center;"> WARNING</p> <p>ONLY THE COMPONENTS SPECIFIED ON THE ACT350 DOCUMENTATION MEDIA CAN BE USED IN THIS TRANSMITTER. ALL EQUIPMENT MUST BE INSTALLED IN ACCORDANCE WITH THE INSTALLATION INSTRUCTIONS DETAILED IN THE USER'S GUIDE. INCORRECT OR SUBSTITUTE COMPONENTS AND/OR DEVIATION FROM THESE INSTRUCTIONS CAN IMPAIR THE SAFETY OF THE TRANSMITTER AND COULD RESULT IN BODILY HARM AND/OR PROPERTY DAMAGE.</p>
	<p style="text-align: center;"> WARNING</p> <p>BEFORE CONNECTING/DISCONNECTING ANY INTERNAL OR EXTERNAL ELECTRONIC COMPONENTS, LOAD CELLS, HARNESSSES OR INTERCONNECTING WIRING BETWEEN ELECTRONIC EQUIPMENT ALWAYS REMOVE POWER AND WAIT AT LEAST THIRTY (30) SECONDS BEFORE ANY CONNECTIONS OR DISCONNECTIONS ARE MADE. FAILURE TO OBSERVE THESE PRECAUTIONS COULD RESULT IN BODILY HARM AND/OR PROPERTY DAMAGE.</p>
	<p style="text-align: center;"> WARNING</p> <p>INSTALLATION AND ANY SERVICE ON THIS EQUIPMENT MUST BE DONE ONLY AFTER THE AREA IS SECURED AS NON-HAZARDOUS BY THE RESPONSIBLE PERSON ON-SITE AUTHORIZED TO DO SO.</p>
	<p style="text-align: center;"> WARNING</p> <p>THE ACT350 IS NOT INTRINSICALLY SAFE! DO NOT USE IN HAZARDOUS AREAS CLASSIFIED AS DIVISION 1, ZONE 0, ZONE 20, ZONE 1 OR ZONE 21 BECAUSE OF COMBUSTIBLE OR EXPLOSIVE ATMOSPHERES.</p>

	 WARNING
	DO NOT ACTIVATE POWER OVER ETHERNET (PoE) ON ETHERNET SWITCHES ON THE ACT350 NETWORK. ACTIVATING PoE MAY RESULT IN DAMAGE TO THE ACT350 TRANSMITTER.
	 WARNING
	IN ORDER TO ENSURE PROPER DISSIPATION OF HEAT FROM THE TRANSMITTER'S PCBs, AND TO AVOID DAMAGE TO THE EQUIPMENT, THE ACT350 MUST BE MOUNTED VERTICALLY, ON A HORIZONTAL DIN RAIL.
	 WARNING
	NOT ALL VERSIONS OF THE ACT350 ARE DESIGNED FOR USE IN HAZARDOUS (EXPLOSIVE) AREAS. REFER TO THE DATA PLATE OF THE ACT350 TO DETERMINE IF A SPECIFIC TRANSMITTER IS APPROVED FOR USE IN AN AREA CLASSIFIED AS HAZARDOUS BECAUSE OF COMBUSTIBLE OR EXPLOSIVE ATMOSPHERES.
	 WARNING
	IN ORDER TO INSTALL THE DIVISION 2 APPROVED ACT350 TRANSMITTER UTILIZING THE U.S. APPROVAL, METTLER TOLEDO CONTROL DRAWING 30315298/30369059 MUST BE FOLLOWED WITHOUT EXCEPTION. IN ORDER TO INSTALL THE CATEGORY 3 MARKED ACT350 UTILIZING THE EUROPEAN APPROVAL, THE DEKRA APPROVAL CERTIFICATE 18ATEX0036X/ IECEx DEK 18.0022X AND ALL LOCAL REGULATIONS MUST BE FOLLOWED WITHOUT EXCEPTION. FAILURE TO DO SO COULD RESULT IN BODILY HARM AND/OR PROPERTY DAMAGE. REFER TO THE ACT350 DIVISION 2 AND ZONE 2/22 INSTALLATION GUIDE 30369090/30467204 FOR ADDITIONAL INFORMATION.
	NOTICE
	OBSERVE PRECAUTIONS FOR HANDLING ELECTROSTATIC SENSITIVE DEVICES.

Disposal of Electrical and Electronic Equipment

In conformance with the European Directive 2012/19/EC on Waste Electrical and Electronic Equipment (WEEE) this device may not be disposed of in domestic waste. This also applies to countries outside the EU, per their specific requirements.



Please dispose of this product in accordance with local regulations at the collecting point specified for electrical and electronic equipment.

If you have any questions, please contact the responsible authority or the distributor from which you purchased this device.

Should this device be passed on to other parties (for private or professional use), the content of this regulation must also be related.

Thank you for your contribution to environmental protection.

Contents

1	Introduction	1-1
1.1.	Inspection and Contents Checklist	1-1
1.2.	Model Identification	1-2
1.3.	PLC Interface Versions	1-3
1.4.	Physical Dimensions.....	1-3
2	Operation	2-1
2.1.	Front Panel	2-1
2.2.	ACT350 Device Main Menu.....	2-3
2.3.	ACT350 Basic Operation Functions	2-15
3	Installation	3-1
3.1.	Mechanical Installation	3-1
3.2.	Electrical Installation.....	3-2
3.3.	DIP Switches	3-11
3.4.	Legal for Trade	3-11
3.5.	Power Supply	3-12
4	Fieldbus Communication	4-1
4.1.	Overview.....	4-1
5	Troubleshooting PLC Connectivity	5-1
6	Configuration and Maintenance Tools	6-1
6.1.	ACT350 Webserver	6-1
6.2.	Setup+ Configuration Tool.....	6-4
7	GEO Codes	7-1
7.1.	Original Site Calibration	7-1
7.2.	New Site GEO Code Adjustment	7-1
A.	Trigger Weighing	A-1
A.1.	Electrical Installation.....	A-1
A.2.	Trigger Weighing Typical Example	A-1
A.3.	Calibration	A-2
A.4.	Configuration of the trigger weighing application	A-3
A.5.	VA Commands	A-8
B.	TCP/IP Communication	B-1
B.1.	Socket Connection	B-1

B.2.	Introduction to MT-SICS Commands	B-1
B.3.	SIX1 Command	B-4
B.4.	TA Command	B-6
B.5.	SI Command	B-6
B.6.	Z Command	B-7
B.7.	ZI Command	B-7
B.8.	T Command	B-8
B.9.	TI Command	B-8
B.10.	TAC Command	B-9
B.11.	I3 Command	B-9
B.12.	I4 Command	B-9
C.	Setpoint	C-1
C.1.	Introduction	C-1
C.2.	Concurrent Mode	C-1
C.3.	Independent Mode	C-3
C.4.	Latch	C-4

1 Introduction

The ACT350 represents the latest METTLER TOLEDO technology and is one of the most versatile weighing transmitters available today for conventional strain gauge weighing technology. The factory pre-configured PLC communication interface in a DIN rail mounting scheme makes the ACT350 a perfect match for basic industrial process weighing applications including:

- Filling
- Dosing
- Checkweighing

Measurement and control applications are enhanced with an ultra-fast A/D-D/A conversion rate of 1200 Hz, patented TraxDSP™ digital filtering technology and a PLC update rate of 800 Hz. The ACT350 delivers fast, precise measurement data from milligrams to tons in a single cost-effective package that easily integrates into control panel systems.

The versatile ACT350 excels in controlling simple filling and dosing applications, delivering best-in-class performance for fast, precise and accurate results in fully automatic operations. Utilize the control capabilities of the ACT350 to effectively manage project costs.

1.1. Inspection and Contents Checklist

Verify the contents and inspect the package immediately upon delivery.

The package should include:

- ACT350/ACT350 DIO Analog Type transmitter
- Safety warnings in multiple languages
- Parts for installation, including ferrite, connectors, screwdriver, etc.

NOTICE

ALL RELEVANT DOCUMENTATION, SOFTWARE, FIELDBUS FILES AND SAMPLE CODE ARE AVAILABLE AT WWW.MT.COM/IND-ACT350-DOWNLOADS

1.2. Model Identification

The ACT350 model number is located on the data plate on the back of the transmitter along with the serial number. Refer to Figure 1-1 to identify the ACT350 configuration.

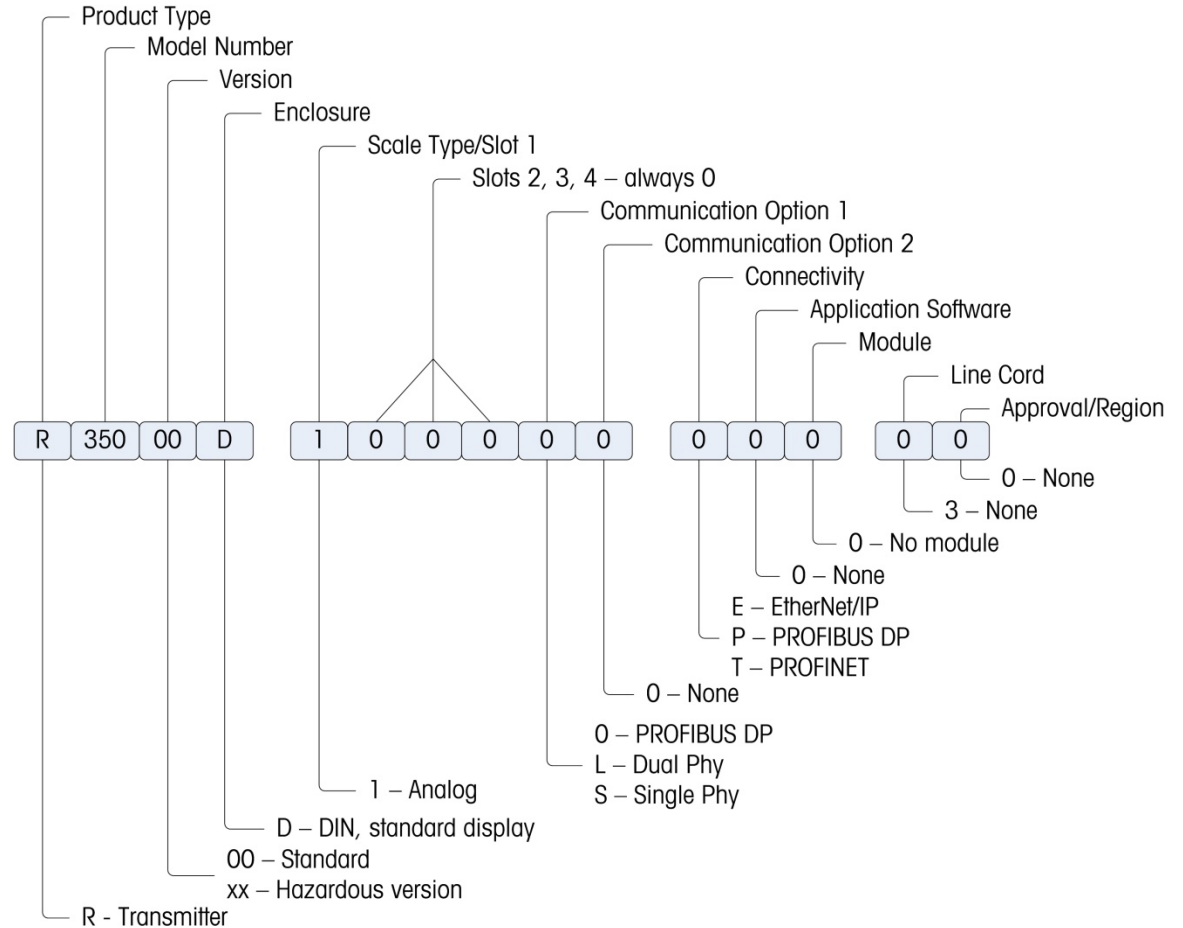

Figure 1-1 ACT350 Model Configurator

Table 1-1: ACT350 Model Configurations

Item Number	Description	Version	Fieldbus Type
30076688	Weight Transm. ACT350 Analog PBDP	ACT350	PROFIBUS DP
30076689	Weight Transm. ACT350 Analog PRNT	ACT350	PROFINET IO
30076690	Weight Transm. ACT350 Analog ETIP	ACT350	EtherNet/IP
30076691	Weight Transm. ACT350DIO Analog PBDP	ACT350DIO	PROFIBUS DP
30076692	Weight Transm. ACT350DIO Analog PRNT	ACT350DIO	PROFINET IO
30076693	Weight Transm. ACT350DIO Analog ETIP	ACT350DIO	EtherNet/IP
30366444	Weight Transm. ACT350xx Analog PBDP	ACT350xx	PROFIBUS DP
30366445	Weight Transm. ACT350xx Analog PRNT	ACT350xx	PROFINET IO
30366446	Weight Transm. ACT350xx Analog ETIP	ACT350xx	EtherNet/IP

1.3. PLC Interface Versions

The ACT350 comes factory-configured with PLC interface options including

- PROFIBUS DP
- EtherNet/IP
- PROFINET IO

Each product version is specific to the PLC interface and cannot be changed to a different fieldbus type.

NOTICE

THIS DOCUMENT DOES NOT FOCUS ON PROGRAMMING OF USER'S PLC. DEVICE DESCRIPTION FILES, SAMPLE CODE, ENGINEERING NOTES AND SAI (STANDARD AUTOMATION INTERFACE) REFERENCE MANUAL CAN BE DOWNLOADED FROM www.mt.com/ind-act350-downloads. USE THESE TO SIMPLIFY YOUR PLC PROGRAMMING WHILE INTEGRATING ACT350.

1.4. Physical Dimensions



Figure 1-2: ACT350 DIN Rail-Mount Enclosure Dimensions

NOTICE

2D AND 3D DRAWINGS ARE AVAILABLE AT WWW.MT.COM/IND-ACT350-DOWNLOADS

2 Operation

2.1. Front Panel

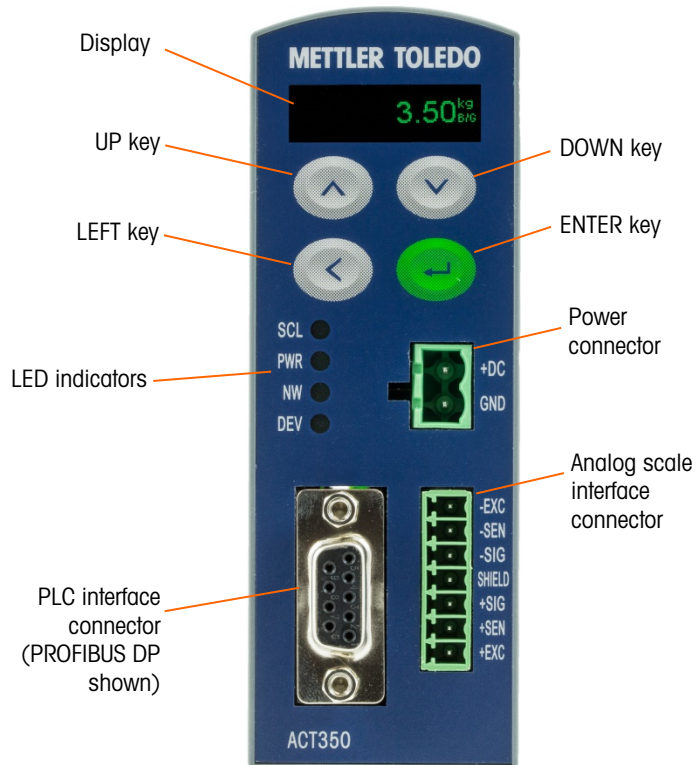

Figure 2-1: ACT350 Front Panel Layout, PROFIBUS

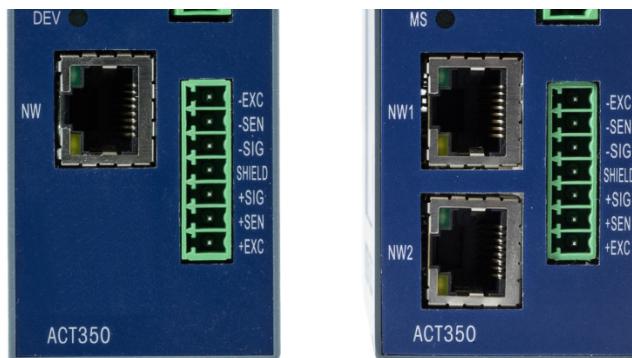

Figure 2-2: ACT350 Front Panel Layout, Single and Dual Ethernet Ports

2.1.1. Display Layout

The ACT350 transmitter has an organic LED (OLED), 128 × 32 dot matrix graphic type display. The display is reserved for scale weight, units, Net/Gross indicator and error messages.

Additional information provided includes:





- Weight unit (lb, kg, g)
- Motion / no-motion condition
- Center of zero
- Gross or net mode



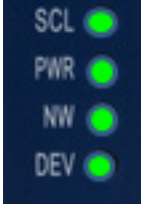

Figure 2-3: Display in Weighing Mode

2.1.2. Front Panel Keys

Four dedicated function keys are located on the front panel to support manual setup configuration. These provide the interface to navigate the setup menu hierarchy and data entry, as well as make setup selections within data entry and drop down boxes.

	<p>ENTER</p>	<p>Press the ENTER key for 3 seconds to access the device menu. Press the ENTER key to make a selection within the device menu and sub-menus.</p> <p>When in a data entry field, press the ENTER key to accept the numeric value entered.</p> <p>When the display is in weighing mode, briefly press the ENTER key to execute the zero operation if the scale weight is within the Pushbutton zero range specified in Setup+ or the webserver.</p>
	<p>UP</p>	<p>Press the UP key to scroll within the device menu and sub-menus. The UP key is also used for incrementing numerals in the numeric data entry field.</p>
	<p>DOWN</p>	<p>Press the DOWN key to scroll within the device menu and sub-menus. The DOWN key is also used for decrementing numerals in the numeric data entry field.</p>
	<p>LEFT</p>	<p>Press the LEFT key to navigate back one step on the device menu tree. The LEFT key is also used to scroll to the left by one numeral in a data entry field. With the left most numeric character highlighted, the next key press will wrap around to the right most numeral.</p>

2.1.3. LED Status Indications

Normal Work	Network Error (Example)	LED	STATUS
		SCL	Scale status: ON okay, flashing indicates scale error
		PWR	Power status: ON okay, OFF error
		NW	While cyclic communication is successful, the LED will remain solid. Otherwise the LED will blink.
		DEV	Device Status: ON okay; flashing contact service

2.2. ACT350 Device Main Menu













From the front panel, press and hold the ENTER key for 3 seconds to access the device menu. The display will change from showing the normal weight display to showing the Information Recall  icon. Press the UP  or DOWN  keys on the front panel to display icons for the various functions listed in Table 2-1.

Table 2-1: Device Menu Icons

	Information Recall	Recall mode for most transmitter information fields.
	Resolution	Temporarily expands weight display resolution for diagnostic purposes
	Comparators	Access to the limit value for all currently enabled comparators.
	Calibration	Access to calibration menu including zero and span adjustment (in non-approved mode only).
	Error Message	Access to list of current error messages
	Language	Selects between English and Chinese
	Setup	Access to setup parameters for the transmitter.

Once focus is in a value field, repeated presses of the UP, DOWN or LEFT keys will cycle back to the beginning, so if the LEFT key is pressed when focus is in the left-most position, focus returns to

the right-most position. In the case of the UP and DOWN keys, the numerical value will cycle through numerical values and the decimal point as follows:

- 
0 > 1 > 2 > 3 > 4 > 5 > 6 > 7 > 8 > 9 > . > . > 0 > 1 > ...
- 
0 > . > . > 9 > 8 > 7 > 6 > 5 > 4 > 3 > 2 > 1 > 0 > . > . > ...

After accepting the value by pressing ENTER and the focus has moved to the parameter description, press the LEFT key to exit to the next higher level of the menu.

Pressing the LEFT multiple times will exit the device menu.

Figure 2-4 shows an example of how to access and modify the value of a parameter. The currently selected item (in focus) is indicated by reverse video.

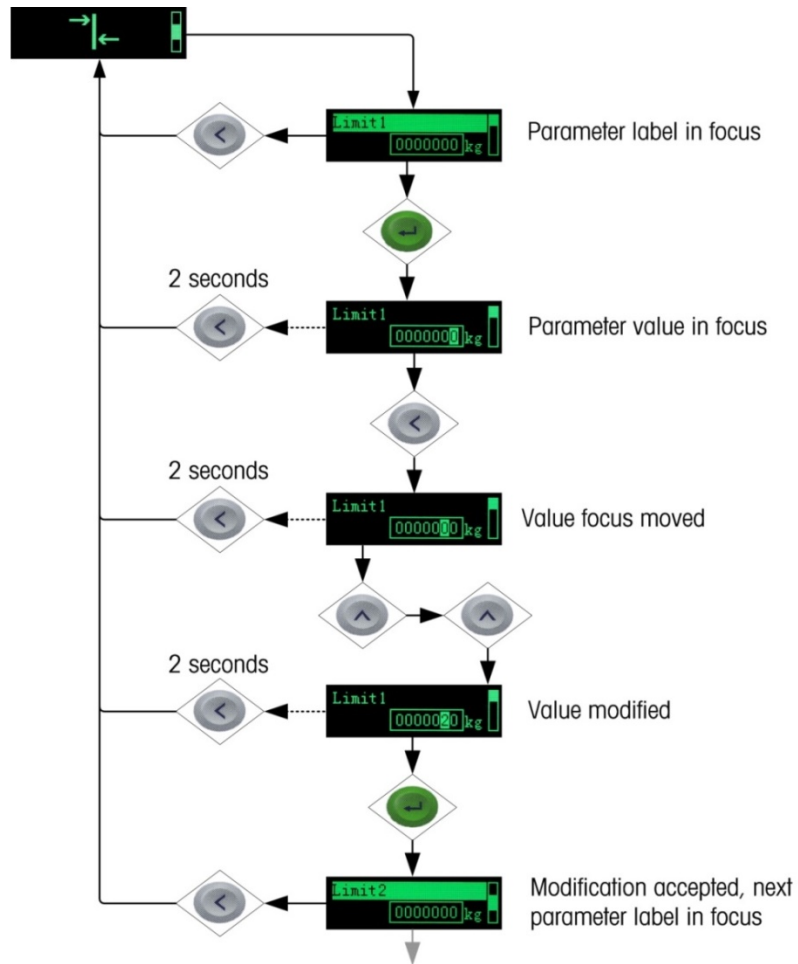

Figure 2-4: Numerical Data Entry Example

2.2.1. Information Recall



Once the Information Recall icon  appears, press the ENTER key to recall specific information about the transmitter. Press the UP  or DOWN  keys on the front panel to display transmitter information.

Table 2-2: Information Recall Menu

Model	Model of the transmitter ACT350 Analog
Serial Number	Serial number of the transmitter
S/W Version	Firmware version of the transmitter
PLC	PLC interface type and communication software version
Device Name (PROFINET)	Device name of the transmitter as it would appear on the network
Node Address (PROFIBUS DP)	Node address of the transmitter on the network
IP Address	IP address of the transmitter
MAC Address	MAC address of the transmitter
Download Link	URL to the ACT350 download page

2.2.2. x10 Resolution

This function expands the weight display resolution by 10 so that a finer weight increment can be seen. It can be enabled by pressing the ENTER key  when the transmitter's device menu has been accessed and the **x10** icon is displayed on screen:





Figure 2-5: x10 Indication

<i>NOTICE</i>
<p>THE x10 DISPLAY RESOLUTION SETTING CANNOT BE CONFIGURED USING SETUP+ OR THE WEBSERVER. THE FUNCTION IS INTENDED FOR DIAGNOSTIC PURPOSES ONLY. THE TRANSMITTER SHOULD NOT BE USED IN THE X10 EXPANDED MODE FOR NORMAL OPERATION. THE DATA OK BIT IS SET TO ZERO WHEN IN X10 DISPLAY MODE TO INDICATE THAT THE ACT350 IS NOT IN NORMAL OPERATING MODE. THE PLC SHOULD CONTINUOUSLY MONITOR THE DATA OK BIT IN THE ACT350 COMMUNICATION TO DETERMINE THE VALIDITY OF DATA RECEIVED BY THE PLC.</p>

2.2.3. Comparators

The device supports a total of five comparators. One, two or all five comparators may be used. The limit of each comparator may be modified by accessing the Comparator menu in the setup menu. Comparator values are limited to 7 digits, and can be written to the device or read from it by the PLC.

2.2.3.1. Setting Comparators

Access the Comparator menu by pressing the ENTER key  when the transmitter's device menu is visible and the  icon is displayed on the device.

The ACT350 only supports a logical comparison of " \geq ", greater than or equal to, for each comparator. For example, if the limit is set to "24.00" kg, the output configured to use this comparator will be set to true only if the live weight is greater than or equal to 24.00 kg. Please note that inputs and outputs can be configured using Setup+ or the webserver.

The operator of range and other comparisons are NOT supported by the ACT350.

To edit parameters other than limits, Comparator configuration must be accessed in setup. Refer to the Numerical Data Entry section for the method used to modify numerical values.



2.2.4. Calibration

Calibration is the process of adjusting the display of the transmitter so that when the scale is empty, the display shows zero gross weight and with a specific amount of weight on the scale, it also shows an accurate weight value.

The ACT350 transmitter calibration menu enables entry of a GEO Code adjustment value, selection of linearity adjustment (**none** [default], three, four or five point), traditional zero calibration and three different types of span calibration:

- **Traditional span calibration** – This uses test weights.
- **Step adjust calibration** - Using a build-up or substitution method of calibration, this method is used for large vessels where only a portion of the required test weights can be placed on the scale.
- **CalFree calibration** – Once certain load cell criteria have been entered manually, the transmitter will automatically calculate the span; no test weights are required.

2.2.4.1. Setting Calibration

Access to the Calibration menu using the device's front panel is accomplished by pressing the ENTER key  when the  icon is displayed on the device. The Calibration menu also can be accessed using the PC-based Setup+ Configuration Tool or the built-in webserver.

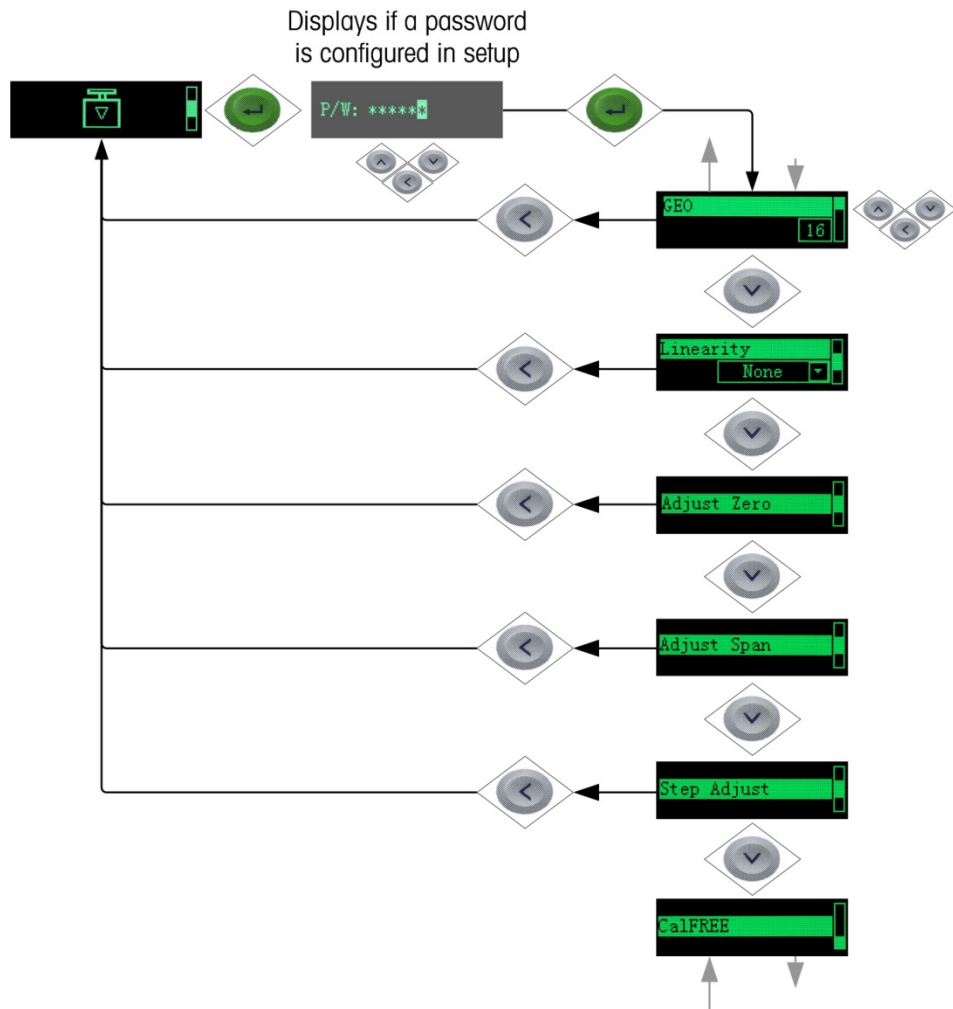

Figure 2-6: Calibration Menu – Overview

2.2.4.2. Setting Geo Code

The Geo code, which sets the appropriate adjustment value for the current geographical location, is selected here. Geo codes are numbered 0–31. See Figure 2-7 for more information on the Geo code setting using the transmitter’s front panel buttons, and refer to Chapter 7, **Geo Codes** to find the appropriate Geo Code for the installation location.

2.2.4.3. Setting Linearity

To set the Linearity Adjustment value, see Figure 2-7. Choose the number of linearity points from the selection box. Options are **None** [default], 3 point, 4 point, 5 point.

Points are distributed as follows:

None	Linearity is disabled
3	Zero, midpoint and highpoint
4	Zero, lowpoint, midpoint and highpoint
5	Zero, lowpoint, midpoint, mid-highpoint, highpoint

2.2.4.4. Zero Calibration and Under Zero Blanking

Scale zero is set simply by emptying the scale and running the "Adjust Zero" calibration routine, as shown in Figure 2-8.

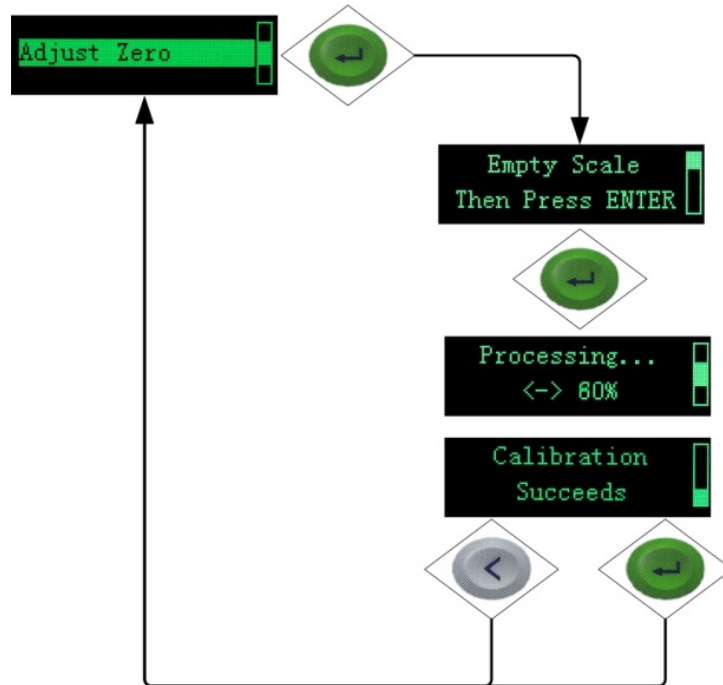

Figure 2-7: Zero Calibration

If the transmitter detects scale motion during the calibration process, it will retry the start of calibration several times and then proceed, displaying a motion indication. In this case, when calibration is complete, the transmitter will present two options – accept or reject the value.

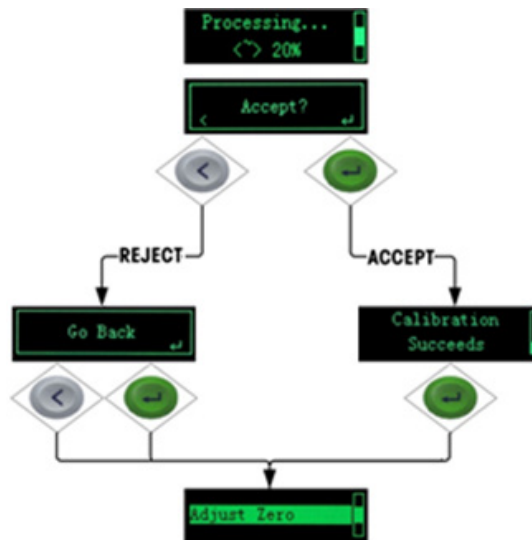

Figure 2-8: Zero Calibration with Motion

Blanking of the display is used to indicate an under-zero condition when the weight on the scale falls below the current zero reference. Set the under zero blanking for the number of divisions (d) that the transmitter is permitted to go under zero before blanking.

NOTICE

A SETTING VALUE OF 0-98 BLANKS THE DISPLAY AT THE SPECIFIED NUMBER OF DIVISIONS BELOW GROSS ZERO. A VALUE OF 99 DISABLES BLANKING UNDER ZERO AND THE TRANSMITTER WILL DISPLAY A WEIGHT UP TO 50% OF THE CAPACITY IN THE NEGATIVE DIRECTION. FOR EXAMPLE, IF THE CAPACITY IS 100KG, BLANKING WILL OCCUR AT ANY VALUE BELOW -50KG.

2.2.4.5. Span Calibration

The scale's span calibration can be determined either with or without a linearity adjustment. With linearity disabled, a single reference point is used to calibrate the scale. This is the normal method for span calibration. In Figure 2-10, the transmitter is configured with three-point linearity – low, mid and high.

The low point is set during zero calibration, and the mid and high points are set during this procedure.

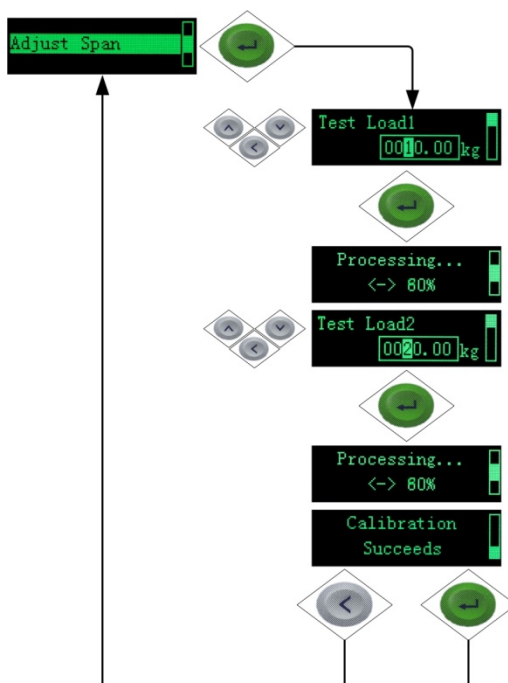

Figure 2-9: Span Calibration

If linearity is enabled, additional mid-range weight reference points are added to the adjustment procedure. Linearity can be enabled or disabled in the Calibration branch of the device menu. Refer to ACT350 Device Main Menu section for the method used to modify numerical values.

2.2.4.6. Step Adjust

Step adjustment is an iterative process in which a build-up or material substitution method of calibration is used to calibrate the span. Each step calibrates a portion of the full span.

This method is typically used with large vessels where only a portion of the required calibration test weights can be placed on the scale at one time. Figure 2-11 shows the logic of the procedure using a simple, two-step example. When sufficient steps have been calibrated, pressing the LEFT button returns the view to the calibration menu.

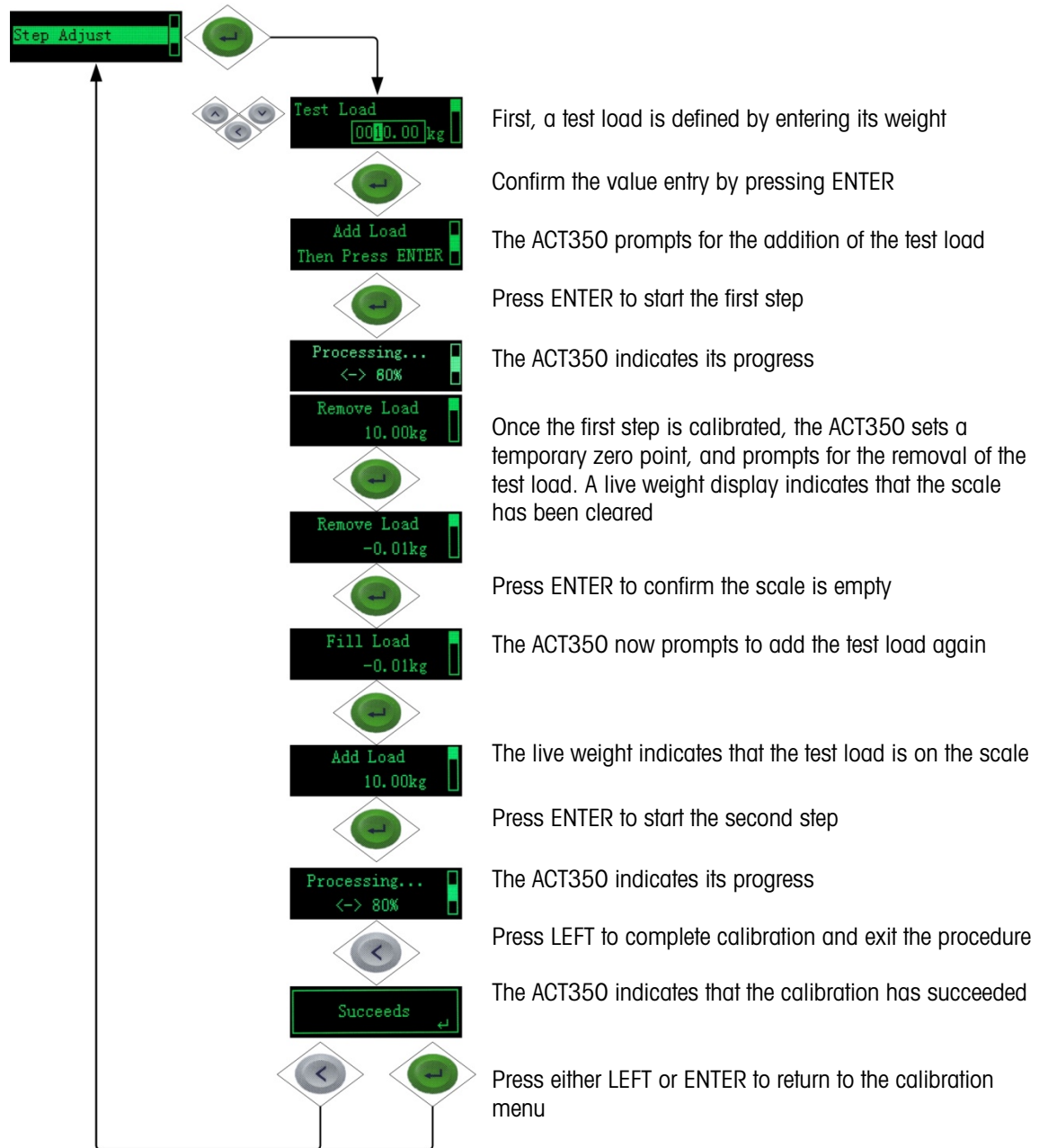

Figure 2-10: Step Adjustment

2.2.4.7. CalFree™

CalFree allows the scale to be calibrated without the use of test weights. The total load cell capacity, unit and output in mV/V must be entered. The system then calculates correct calibration for the scale. Figure 2-12 provides a visual representation of the CalFree calibration procedure.

2.2.4.7.1. Notes on Load Cell Capacity and Rated Cell Output

- For load cell capacity, enter the sum of all load cell capacities. For example, for three 50t load cells, enter 150,000 kg.
- For systems with passive dummy load cells, enter the value as if all legs have live load cells. For example, for a system with two 50t live load cells and two passive supports, enter 200,000.
- For Rated Cell Output, enter the sensitivity of each live load cell in mV/V – for example, 2.0000. For multiple load cells, enter the average sensitivity of all cells.

The ACT350 transmitter allows calibration of the scale without using test weights. This is based on manual entry of capacity and performance data from the load cell or load cell platform. This data can be found on the load cell calibration certificate found at <http://calfree-cert.mt.com>. This method of calibration can be used for initial check-out and testing of systems or when a large structure is used as the weighing vessel and it is not possible to apply test weights to the structure. METTLER TOLEDO highly recommends that test weights be used whenever possible, as this provides the most accurate method of calibration.

The Rated Cell Output and Cell Capacity values cannot be zero, and are limited to 7 digits.

NOTICE

SCALE CALIBRATION USING CALFREE™ WILL NOT BE ACCURATE WHEN USING ZENER DIODE BARRIERS (SUCH AS METTLER TOLEDO ISB05 AND ISB05X) BETWEEN THE TRANSMITTER AND THE SCALE. DO NOT USE CALFREE™ WHEN BARRIERS ARE INSTALLED.

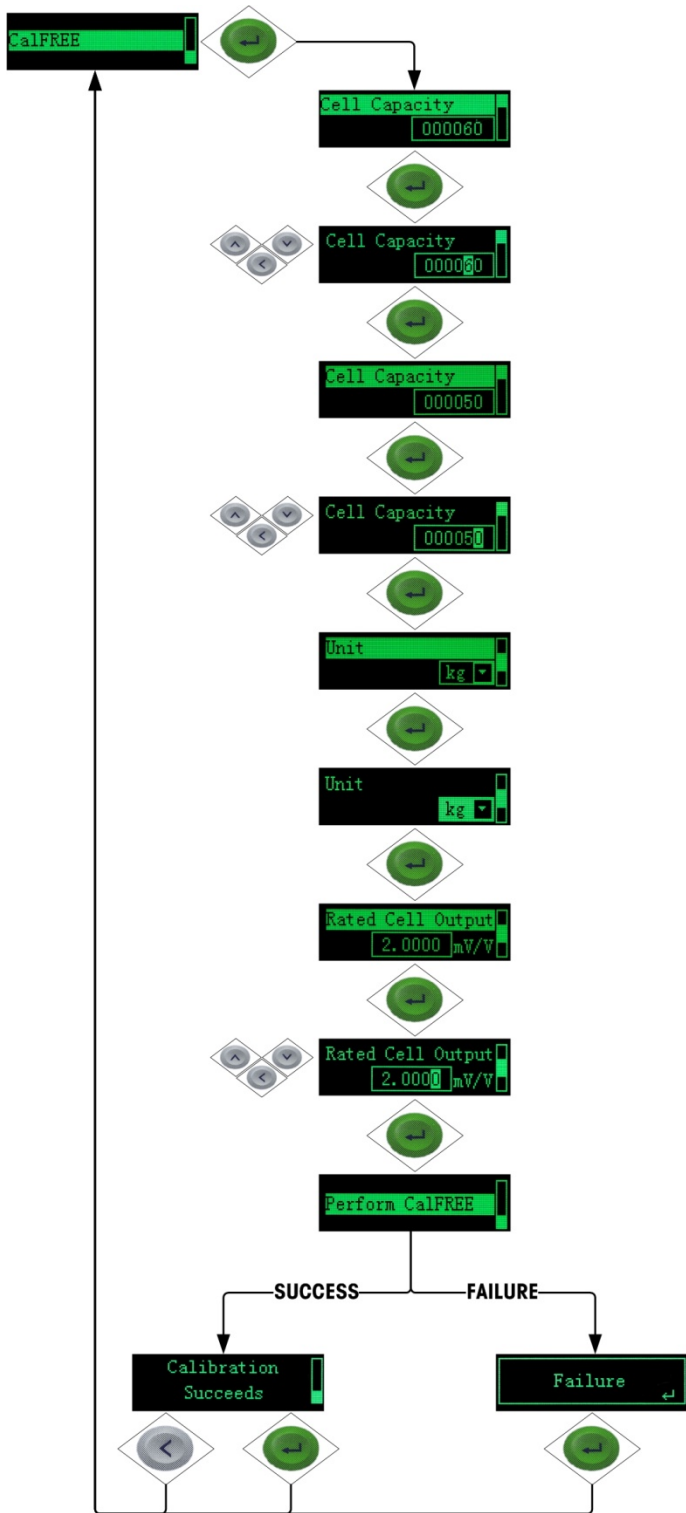



Figure 2-11: CalFree

2.2.5. Language

The ACT350 supports a device menu in **English** [default] and in Chinese.

2.2.6. Setup Access

The last icon displayed in the device menu from the front panel is Setup , where many of the transmitter's programming parameters can be viewed and modified. It is not intended that operators enter the setup mode after a weighing system is installed and is operational. It should not be necessary for an operator to access setup.

2.2.6.1. Capacity & Increment

Unit	Select the units for the scale from grams (g), kilograms (kg) or pounds (lb)
Capacity	Select the maximum capacity for the scale. Always confirm the increment size after changing the capacity since one setting may affect the possible options for the other.
Increment	Select the increment size for the scale from a drop down list. Only possible options based on your currently selected capacity will be available here. If the increment size you need is not available, you may need to decrease your capacity.

2.2.6.2. PLC Settings

The PLC menu of the ACT350 allows the user to change settings related to how the ACT350 communicates to the PLC. These settings can also be changed in Setup+ or the webserver. See the Fieldbus Communication section of this manual for more information on the Standard Automation Interface (SAI).

Assignment	SAI: The ACT350 always uses the Standard Automation Interface (SAI)
Format	1 Block Format: Provides both cyclic floating point data (typically weight) along with basic status information to the PLC 2 Block Format: Provides all of the information from the one block format plus an additional block of more detailed status information.
Byte Order	Automatic, Big Endian or Little Endian: Recommended to use the default automatic setting unless communication issues occur. This will automatically determine the proper byte order needed based on your communication protocol
PROFIBUS/ PROFINET/ EtherNet/IP	MAC Address: Displays the MAC address, which cannot be edited. DHCP: Dynamic Host Configuration Protocol (DHCP) can either be enabled or disabled . This setting is disabled by default. IP Address: Default value is 192.168.000.002 . Each device on your network must have a unique IP address. So if using multiple ACT350s, the IP address of all but one must be changed. See the PC Setup section of this document for more information. Subnet Mask: Default value is 255.255.255.000 . There is typically no need to change this value. See the PC Setup section of this document for more information. Gateway: Default value is 000.000.000.000 . There is typically no need to change this value.

2.2.6.3. Serial Settings

Change these settings to match the serial settings of your PC in order to establish communication with the Setup+ program.

Baudrate	Select serial communication speed of 300, 600, 1200, 2400, 4800, 9600, 19200, 38400, 57600 or 115200 bits per second.
Data Bit	Select either 7 or 8
Parity	Select either None, Even or Odd
Serial Test	Perform a serial test. The will transmit a number once per second. The transmitted number will start at 0 and increment by one each second. The ACT350 will also display serial messages it receives during the test.

2.2.7. Password Security

Note that a security password can be enabled in setup from the PC-based Setup+ Configuration Tool or the built-in webserver. When a password is set, it must be entered to access setup. This protects the setup parameters from inadvertent changes. The default password is "000000". Please note that if the password is lost, only a master reset can revert the password to the default value.



Figure 2-12: Password Entry Screen

2.2.8. Reset Configuration and Master Reset

2.2.8.1. Reset Configuration

To reset all configured items except calibration data:

1. Remove power from the transmitter.
2. Locate the DIP switches, accessible from the underside of the housing.
3. Set both DIP switches, 1 and 2, to ON (up, in Figure 2-14), and restore power to the transmitter.

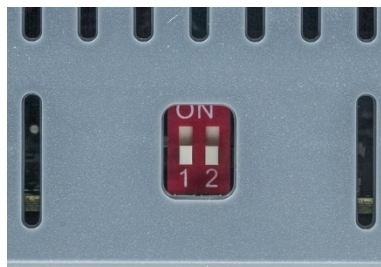

Figure 2-13: DIP Switches

4. Set both DIP switches to OFF.

2.2.8.2. Master Reset

A master reset restores all settings to their factory default values:

1. Remove power from the transmitter.
2. Set switch **2** to its ON position and restore power to the transmitter. The ACT350 will prompt for confirmation.



Figure 2-14: Master Reset Confirmation

3. Press ENTER on the front panel to perform the master reset.
4. Set Switch **2** to OFF.

2.3. ACT350 Basic Operation Functions

2.3.1. TCP/IP Communication

The software version V1.05.0012 or later enables ACT350 to “talk” with a PC or HMI via TCP/IP communication. The PC or HMI can connect to ACT350 to read weight or status information and perform remote Zero/Tare/Clear operations over the Ethernet connection. This communication functionality is only available for ACT350 PROFINET or EtherNet/IP versions.

Refer to Appendix B for details.

2.3.2. Fast Replacement via LLDP(Link Layer Discovery Protocol)

The LLDP feature is only available for PROFINET versions of the ACT350. This feature makes it very easy to replace the old or faulty unit with a new one. It is only necessary the new ACT350 use the same physical port on the switch that the old ACT350 had previously been using. When powering up, the networking information will be downloaded automatically from the PLC to the new ACT350 unit.

2.3.3. Zero

The Zero function is used to set or reset the initial zero reference point of the transmitter. There are two types of zero setting modes:

2.3.3.1. Green ENTER Button

The zero function can be accomplished by a short press of the green ENTER  scale function key. The Zero range selections include Disabled, **2%** [default] or 20% plus or minus from the calibrated zero point. A change to the default setting is done via the PC-based Setup+ Configuration Tool or the built-in webserver. If the current scale weight is outside the zero range when a pushbutton zero is commanded, the transmitter will display a message:

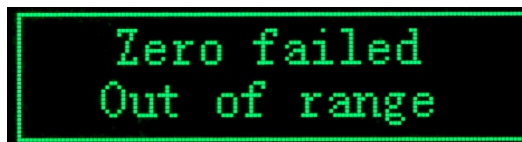

Figure 2-15: ENTER button Zero Failure Message

Remote initiation of the semi-automatic Zero command is possible via a command initiated by the PLC interface.

2.3.3.2. Power Up

The Power Up mode setting determines if at power up, the transmitter will restart with the most recent zero reference point it had before power down or if it will reset to the calibrated zero reference.

The selections include **Reset** [default] and **Restart**.

2.3.3.2.1. Reset

With the setting on Reset, the last zero calibration value will be used as the zero reference point. The Power Up Zero capture range selections include **Disabled** [default], 2% or 10% plus or minus. If the range setting is enabled, the Power Up Zero is applied only when the weight reading on the scale is within the selected range around the originally calibrated zero reference. For example, if the range setting for Power Up Zero is set at +/- 2%, Power Up Zero will only occur when the weight reading on the scale is within +/- 2% of scale capacity above the original calibrated zero reference. If the weight on the scale is outside of the zero range, the display will indicate **EEE** until the weight is adjusted to within this range and zero is captured.

2.3.3.2.2. Restart

A setting of Restart enables the transmitter to reuse the most recent zero reference weight after a power cycle so it returns to the same, previously-displayed gross weight value. The Power Up Zero setting is configured using the PC-based Setup+ Configuration Tool or the built-in webserver.

2.3.4. Tare

The tare value is subtracted from the gross weight measurement, providing the computation of the net weight (material without the container). The tare function can also be used to track the net amount of material being added to or removed from a vessel or container. In the second case, the weight of the material inside is included with the tare weight of the container and the display reflects the net amount being added to or removed from the vessel. Tare is captured by PLC command, by a configured input on an ACT350 unit or via the webserver. Tare is cleared by PLC command, by a configured input on an ACT350 unit or via the webserver. Inputs and outputs can be configured using Setup+ or the webserver.

2.3.5. Filter

In many weighing applications, vibration can introduce error into your system or cause delays in the transfer of weight to your automation device. It is always recommended to first attempt to mechanically isolate your scale from the surroundings. When this cannot adequately be done, use the electronic filtering inside the ACT350. The Filter section offers three settings: Weighing Mode, Limit Frequency and Environment.

Weighing Mode	<p>Normal: Should only be used for non-automatic, human-powered weighing. Gives the most stable response that is required for "legal for trade" weighing. Not recommended with a process controlled by an automation device.</p> <p>Dynamic: Intended setting when process is controlled by automation device such as a PLC.</p> <p>Trigger Weigh: Intended setting when using trigger weighing mode. See Appendix A for additional information.</p>
Limit Frequency	<p>1-20 Hz: Marks the point at which the filtering process begins to affect the disturbance. Disturbances above the limit frequency will have filtering applied. Recommendation is to start at 20 Hz and reduce the frequency only after adjusting the environment setting. The lower the frequency, the better the disturbance rejection, but it will extend the settling time.</p>
Environment	<p>Very Stable, Stable, Standard, Unstable, Very Unstable: Sets the level of attenuation applied to the signal above the limit frequency. A very stable environment will have the least attenuation applied to the signal and a very unstable environment will have the strongest attenuation. It is recommended to adjust this value first when changing filter settings. Start with "very stable" and work your way down.</p>

2.3.5.1. Trigger Weighing

Trigger weighing mode is used to determine the weight value during a dynamic weighing process of the weighing object. The key technical indexes are the weighing accuracy and throughput rate. More information is available in Appendix A, **Trigger Weighing**.

2.3.6. Error Messages

With the Errors icon  in view, press the ENTER key to access a listing of current error messages.

Table 2-3: ACT350 Faults

Error	ACT350 Display	Description	Action
002	Local calib. in process or Setup+ calib. in process	Calibration in process. Distinguishes between calibration performed in the ACT350, and calibration performed from Setup+	Wait for calibration to finish
005	NW Module init.fail	SAI initialize fail	Cycle power; call service if issue persists
006	NW connection disconnected	Lost connection to network	Check cable or connector
009	Board info. err	Hardware information error	Cycle power; call service if issue persists
010	Calib. err	Calibration block data error; block data is lost	Perform master reset; Re-calibrate
011	Scale err	Scale block data error; block data is lost	Perform master reset Perform setup for scale block

Error	ACT350 Display	Description	Action
012	Term. err	Transmitter block data error; block data is lost	Perform master reset Perform setup for transmitter block
013	APP. err	Application block data error; block data is lost	Perform master reset Perform setup for application block
014	NW. err	Communication block data error; block data is lost	Perform master reset Perform setup for communication block
015	Maint. err	Statistics block data error; block data is lost	Perform master reset Perform setup for maintenance block
016	Analog system A/D fail	Lost analog signal; abnormal functioning of scale	Call service
018	Zero failed Motion	Scale in motion when Zero attempted	Zero when scale is stable
019	Zero failed net mode	Scale in net mode when Zero attempted	Clear tare before zeroing
020	Zero failed out of range	Weight out of Zero range	Unload scale and zero
021	Zero failed Zero disabled	Zero attempted when function disabled in setup	Enable Zero function in Setup
022	Tare failed Motion	Scale in motion when tare attempted	Tare when scale is stable
027	Tare failed Not rounded value	Preset tare value not in display increment size	The preset tare value must be rounded to the same increment
028	Tare failed Value too small	Tare value too small	The preset tare value must be minimum of 1 display increment
029	Tare failed Zero not captured	Power-up zero not captured; Zero not captured after power cycle (with Zero capture enabled) then tare was attempted	Disable zero capture at power-up or unload scale and power-up again, then tare
030	Tare Failed, Scale Over capacity	Tare was attempted while scale was over capacity	Remove weight and tare within weighing range
031	Tare failed Negative value	Tare value under zero	The preset tare value must be positive
035	Analog saturation	A/D converter is saturated	Reprogram Scale Capacity

3 Installation

3.1. Mechanical Installation

The ACT350 mounts to a standard DIN rail. DIN mount includes an integral transmitter grounding system, visible in Figure 3-1.

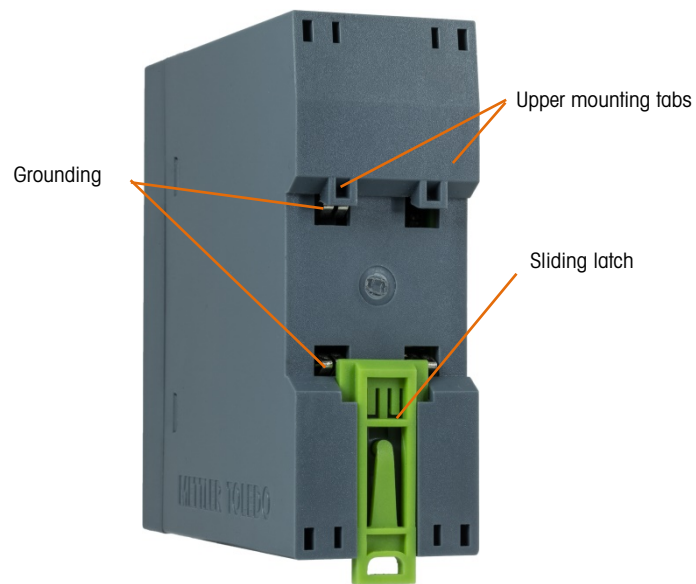

Figure 3-1: DIN-Mount Latch

To mount the ACT350 on a rail, open the latch by pulling down, then position the transmitter so that its upper tabs rest on the DIN rail.

Use a screwdriver to close the latch and secure the transmitter in position.

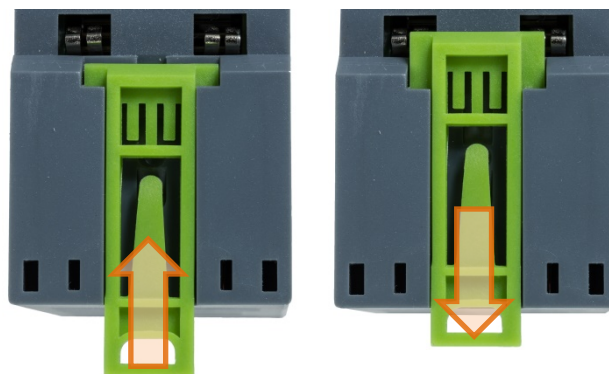



Figure 3-2: Latch Closure

To remove the ACT350, simply put the blade of a screwdriver in the latch and press it downward.

	 WARNING
	<p>IN ORDER TO INSTALL THE DIVISION 2 APPROVED ACT350 TRANSMITTER UTILIZING THE U.S. APPROVAL, METTLER TOLEDO CONTROL DRAWING 30315298/30369059 MUST BE FOLLOWED WITHOUT EXCEPTION. IN ORDER TO INSTALL THE CATEGORY 3 MARKED ACT350 UTILIZING THE EUROPEAN APPROVAL, THE DEKRA APPROVAL CERTIFICATE 18ATEX0036X/ IECEx DEK 18.0022X AND ALL LOCAL REGULATIONS MUST BE FOLLOWED WITHOUT EXCEPTION. FAILURE TO DO SO COULD RESULT IN BODILY HARM AND/OR PROPERTY DAMAGE. REFER TO THE ACT350 DIVISION 2 AND ZONE 2/22 INSTALLATION GUIDE 30369090/30467204 FOR ADDITIONAL INFORMATION.</p>
<p><i>NOTICE</i></p>	
<p>IN ORDER TO ENSURE PROPER DISSIPATION OF HEAT FROM THE TRANSMITTER'S PCBs, AND TO AVOID DAMAGE TO THE EQUIPMENT, THE ACT350 MUST BE MOUNTED VERTICALLY, ON A HORIZONTAL DIN RAIL.</p>	

3.2. Electrical Installation

Figure 3-3 shows the ACT350 connections and their functions.

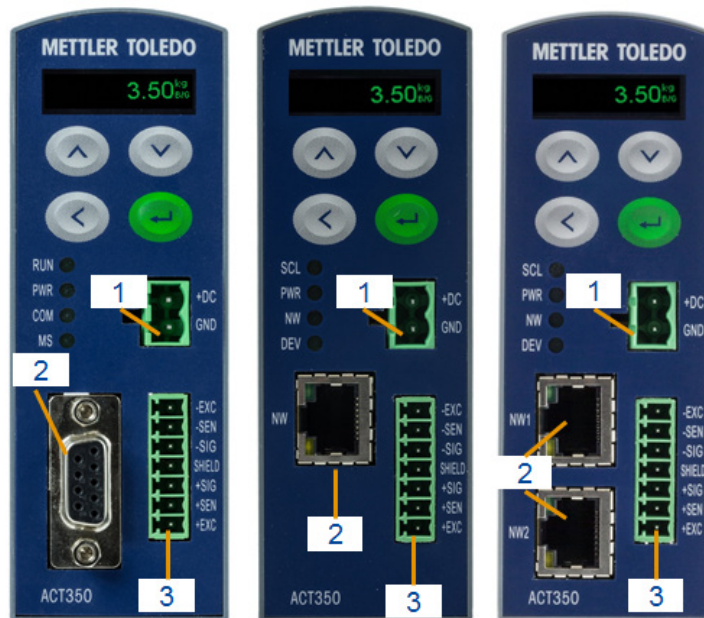

Figure 3-3: ACT350 – PROFIBUS (left) and PROFINET or EtherNet/IP (right)

Function Key:

- 1 Power connector (12- 30 VDC)
- 2 Fieldbus connection (PROFIBUS, PROFINET, Ethernet/IP)
- 3 Analog scale interface (Number of load cells: up to 8x 350Ω or 20x 1000Ω; 1-2 mV/V; Number of scale: 1; Number of scale ranges: 1; Load cell excitation voltage; 5 VDC; 6 wire connection)

NOTICE

ACT350 TRANSMITTERS MAY HAVE A SINGLE PORT OR DUAL NETWORK PORTS DEPENDING ON TYPE OF THE ACT350. ETHERNET/IP AND PROFINET ACT350 HAVE MULTIPLE PORT OPTIONS AVAILABLE, WHILE PROFIBUS ACT350 ONLY SUPPORTS SINGLE PORT OPERATION.

NOTICE

THE SPECIAL AUTOMATIC GROUNDING SYSTEM AT THE BACK OF THE UNIT IS PRESENT TO ENSURE THAT THE UNIT IS GROUNDED TO THE DIN RAIL. SEE FIGURE 3-1

3.2.1. RS-232 Serial Connection

The serial RS-232 connection on top of the transmitter is used for service purposes only **Figure 3-4**.

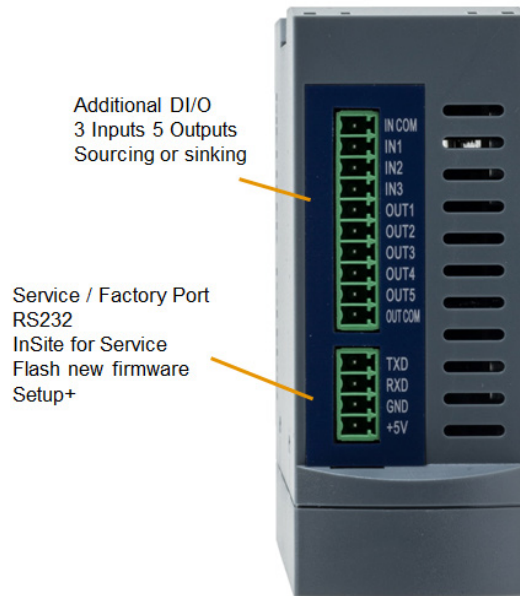

Figure 3-4: ACT350, Top View (DIO model shown)

The Figure 3-5 presents the correct RS-232 wiring connection.

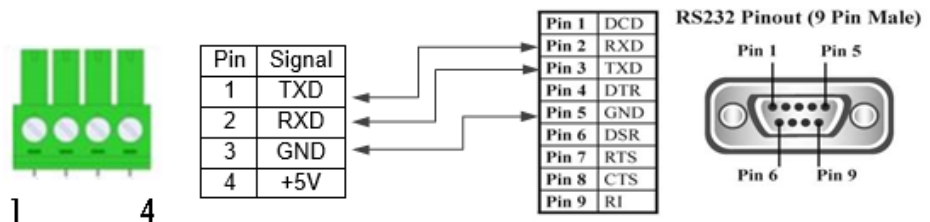

Figure 3-5: RS-232 Wiring Connection

NOTICE

DIO IS AVAILABLE IN VERSIONS WITH DUAL PORTS.
THE RS-232 PORT CAN BE USED TO CONNECT ACT350 TO THE PC-BASED SETUP+ CONFIGURATION TOOL.
THIS TOOL IS AVAILABLE ONLINE AND CAN BE DOWNLOADED AT WWW.MT.COM/IND-ACT350-DOWNLOADS

3.2.2. Digital Inputs and Outputs Connection

Three digital inputs and five outputs are located on top of each ACT350DIO version Figure 3-4 and Table 3-1 show the digital input and output specifications.

Table 3-1: Digital Inputs and Outputs Specification

	Input	Output
Permissible input voltage	0 ~ 24 VDC	5~30 VDC
Logical Low-level	0 ~ 5 VDC	
Logical High-level	10 ~ 24 VDC	
Input resistance	>3KΩ	
Max.current of one output		<150mA
Accumulated current of all outputs		<750mA
Sinking Connection	GND connected to IN-COM	GND connected to OUT-COM
Sourcing Connection	Power source to IN-COM	Power source to OUT-COM
Default function	Zero	
Polarity Value	+True(Default) or -True	
Available Functionality	None; Clear Tare; Tare; Zero	None; Center of Zero; Comparator 1-5; Fault; Motion; NET; Over Capacity; Under Zero

Example: Using a rising-edge input signal to trigger the ACT350 to perform a Zero operation, "Polarity" can be set as "+ True" and "Assignment" as "Zero". Refer to Figure 3-6:

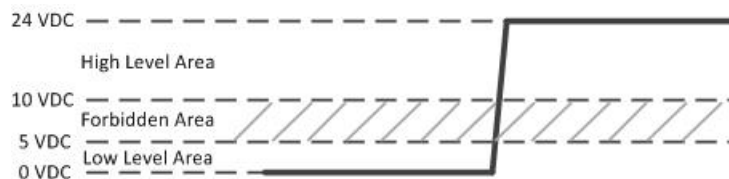

Figure 3-6: A Rising-edge Trigger Signal on Input

Using a falling-edge signal on the input to trigger ACT350 to perform a Tare operation, "Polarity" can be set as "- True" and "Assignment" as "Tare". Refer to Figure 3-7.

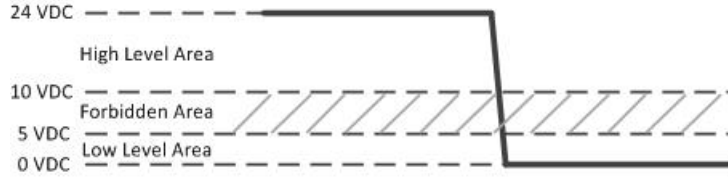

Figure 3-7: A Falling-edge Trigger Signal on Input

NOTICE

DO NOT USE INPUT VOLTAGE BETWEEN 5 – 10 VDC. UNSTABLE INPUT OPERATION WILL RESULT. SEE FIGURE 3-6 AND 3-7 FOR PROPER OPERATION.

Digital inputs and Outputs electrical connection instructions are shown below from Figure 3-8 to Figure 3-11

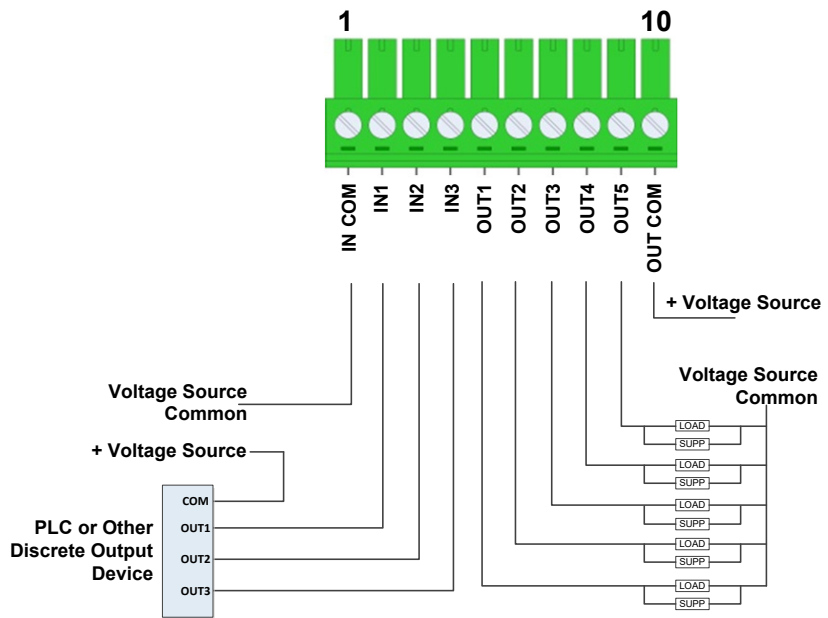

Figure 3-8: Sinking Input, Sourcing Output

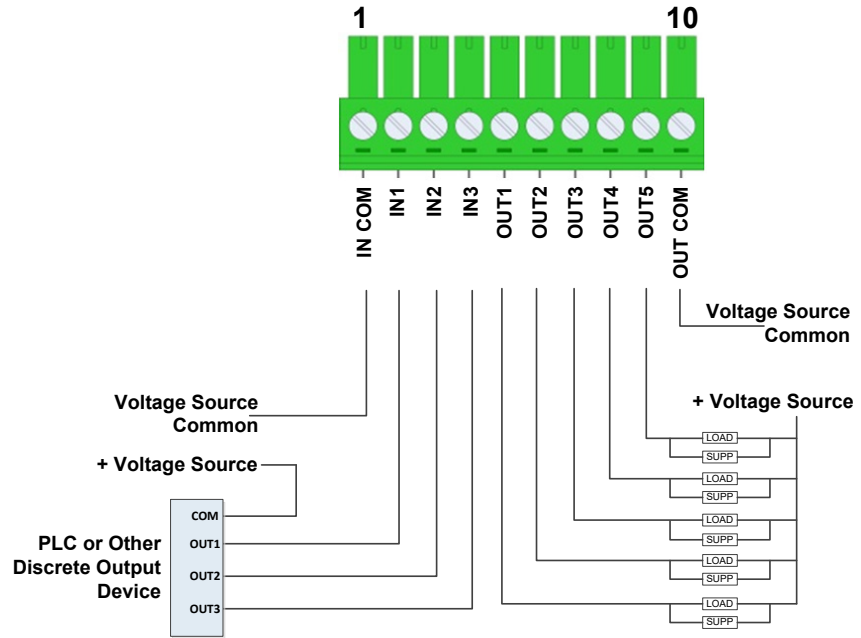

Figure 3-9: Sinking Input, Sinking Output

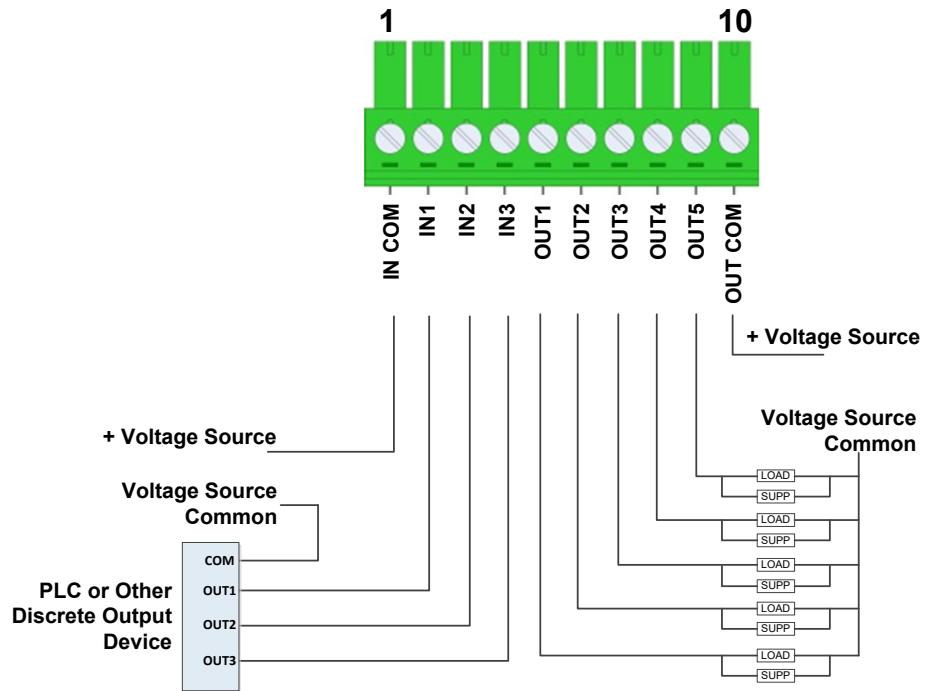

Figure 3-10: Sourcing Input, Sourcing Output

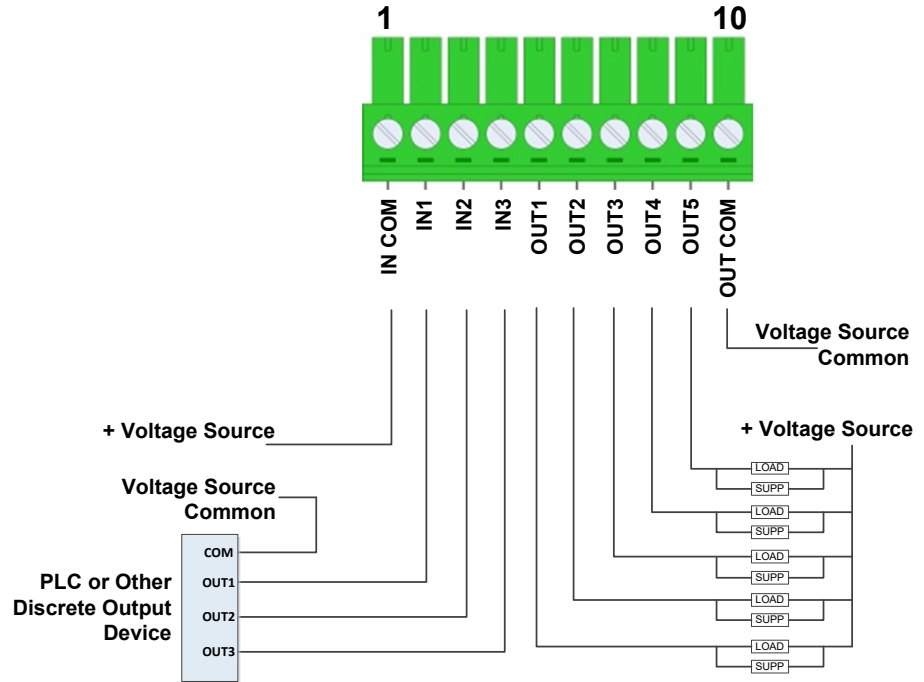

Figure 3-11: Sourcing Input, Sinking Output

3.2.3. Analog Load Cell Connection

For ESD protection, cabling for the analog load cell must include a ferrite and a silicone protection sleeve, included with the transmitter.

Install the ferrite by passing it through the ferrite and wrapping it around once, as indicated here.

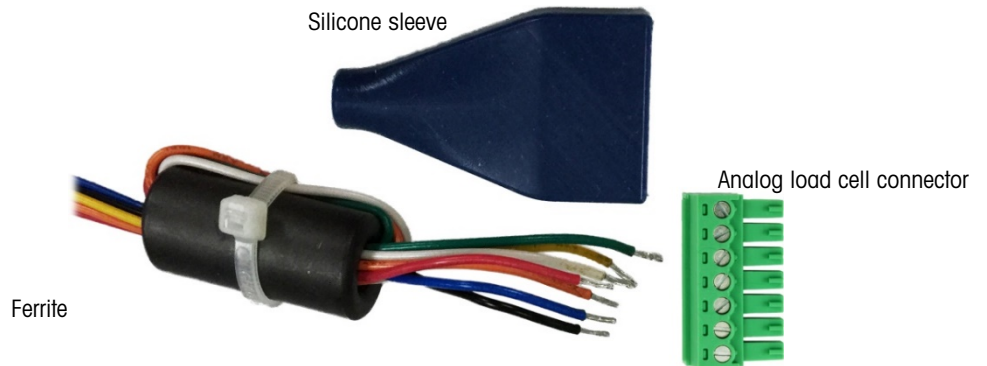

Figure 3-12: Ferrite Installed on Analog Load Cell Cable

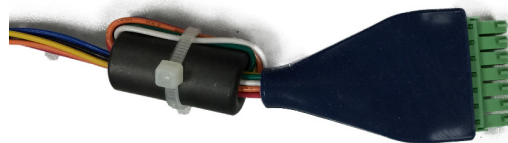

Figure 3-13: Installed Ferrite

NOTICE

TO ACCOMMODATE THE FERRITE IT MAY BE NECESSARY TO CUT THE SILICON SLEEVE TO SIZE.

Following table shows the difference of connecting 6-wire and 4-wire load cells:

Table 3-2 Connecting 6-wire and 4-wire load cells

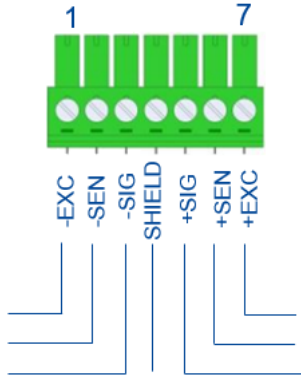
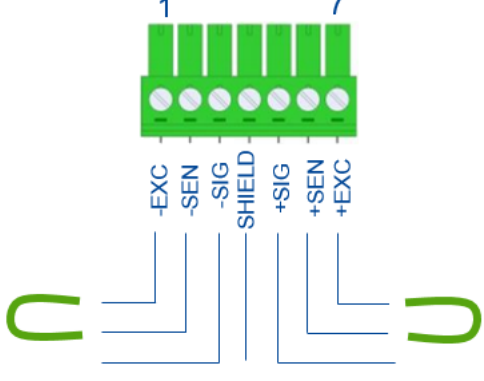
6-wire load cells	4-wire load cells
	
Connect according to the signal diagram	Add jumper wires between –EXC and –SEN; and between +EXC and +SEN

Following table provides recommended Maximum Cable Lengths.

Table 3-3 Recommended Maximum Cable Lengths

TSR (Ohms)	24 Gauge (meters/feet)	20 Gauge (meters/feet)	16 Gauge (meters/feet)
350	234/800	610/2000	1219/400
87 (4 -350 Ω cells)	60/200	182/600	304/1000
43 (8 -350 Ω cells)	30/100	91/100	152/500

3.2.4. PLC Connection

To connect an ACT350 with a PLC, use a fieldbus connection port shown on Figure 3-3. This document doesn't focus on programming a user's PLC. Device description files, sample code, engineering notes and SAI (Standard Automation Interface) reference manual can be downloaded from www.mt.com/ind-act350-downloads. Use these to simplify your PLC programming while integrating ACT350.

Following figures present examples of PLC connection of ACT350's with single and dual ports.



Figure 3-14: PLC Connection, Single Port Version, Single Line Connection.

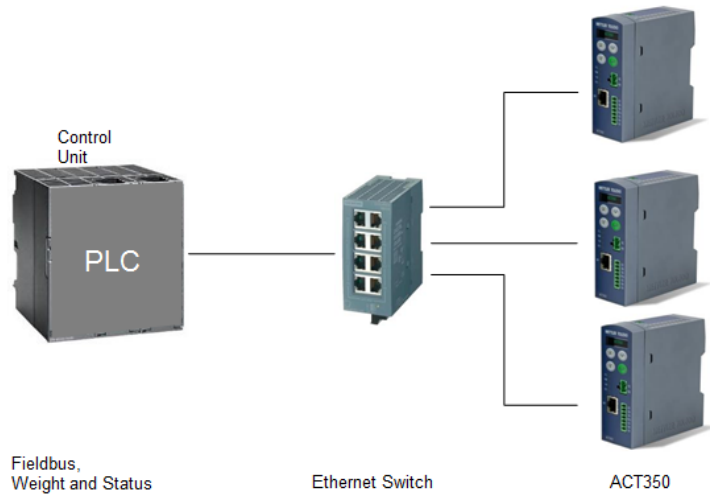

Figure 3-15: PLC Connection, Single Port Version, Multi-Line Connection

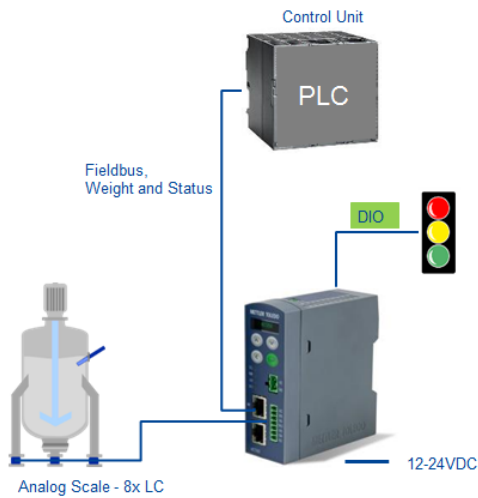

Figure 3-16: Dual Port Version, Single Line Connection



Figure 3-17: DIO and PLC Connection Dual Port Version.

NOTICE

ETHERNET CABLES ARE THE INDUSTRY STANDARD 8P8C (RJ45).

3.2.5. MRP and DLR Ring Topology



All PROFINET ACT350DIO (dual port versions) of the ACT350 support the setting up of a **MRP** (Media Redundancy Protocol) redundant topology in the form of a ring, both for IO communication and for the standard TCP/IP communication.



All Ethernet IP ACT350DIO (dual port versions) of the ACT350 support the setting up of a **DLR** (Device Level Ring) redundant topology in the form of a ring, both for IO communication and for the standard TCP/IP communication.

3.3. DIP Switches

Two DIP switches, 1 and 2, are accessible from the underside of the ACT350's housing. Table 3-3 summarizes the functions of the DIP switches.

Table 3-4: DIP Switch Functions

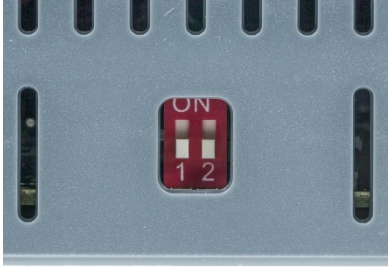
ACT350 DIP Switches	Legal for Trade	Reset	Function
	Switch 1	Switch 2	
	OFF	OFF	Normal operation
	ON	OFF	Legal-for-trade mode; calibration data protected
	OFF	ON	Master reset of all data during transmitter power-up
	ON	ON	Reset of all except calibration data during transmitter power-up

3.4. Legal for Trade

When the transmitter is certified as legal for trade, DIP switch 1, accessible on the underside of the housing, must be set to ON. A metrological seal must be placed over the DIP switch array to prevent this setting from being changed.

Please refer to Figure 3-18 for the method to seal the ACT350 Transmitter.

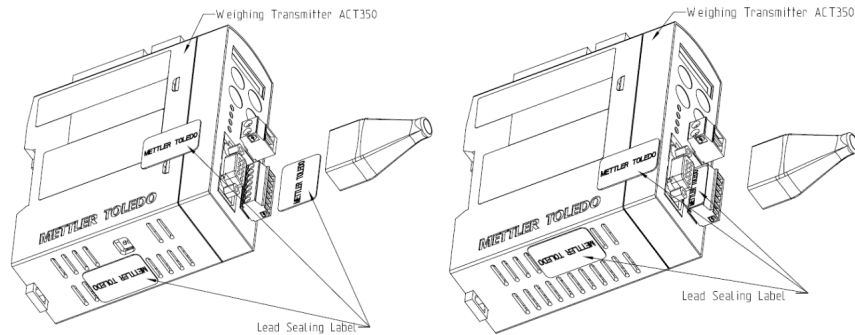

Figure 3-18 ACT350 Sealing Diagram

NOTICE

WHEN THE TRANSMITTER IS IN LEGAL FOR TRADE MODE, METROLOGICAL SIGNIFICANT SETTINGS CANNOT BE ACCESSED VIA KEYPAD, WEBSERVER OR IN SETUP+. THESE INCLUDE UNIT, CAPACITY, INCREMENT SIZE, CALIBRATION, ZERO AND STABILITY SETTINGS.

3.5. Power Supply

The ACT350 transmitter is powered only by external DC input (12V to 30V).

	ACT350 1-Port PBDP		ACT350 1-Port PRNT		ACT350 1-Port ETIP	
	Current mA	Power Watts	Current mA	Power Watts	Current mA	Power Watts
12V	320	4	259	3	248	3
24V	160	4	128	3	123	3
30V	131	4	104	3	100	3

	ACT350 2-Port PBDP		ACT350 2-Port PRNT		ACT350 2-Port ETIP	
	Current mA	Power Watts	Current mA	Power Watts	Current mA	Power Watts
12V	320	4	367	5	367	5
24V	160	4	184	5	184	5
30V	131	4	152	5	152	5

4 Fieldbus Communication

4.1. Overview

The Standard Automation Interface (SAI) is a protocol designed to exchange data between METTLER TOLEDO devices and third-party automation systems. This interface provides the following:

- A common data layout for load cells, terminals and other devices regardless of the physical interface or automation network used.
- A single protocol for the convenience of automation integrators, control system programmers and our automation customers.
- A flexible protocol for diverse devices.

4.1.1. Communication Modes

The protocol has two primary modes of operation.

- cyclic data
- acyclic data

NOTICE

ACYCLIC DATA IS ALSO REFERRED TO AS ASYNCHRONOUS DATA OR EXPLICIT MESSAGING.

4.1.2. Cyclic Data

Cyclic data is broken up into sections of data. Each section represents a block. Each block of data contains four words of 16 bits each.

The data within these words can express numeric values, individual bits which represent state or command depending on the type of block specified.

Two fixed formats divided into blocks (1 block, 2 blocks) are available for the ACT350. The default format is the two block format with eight words in and eight words out. The number of input words (data sent from the ACT350 to the process controller) and output words (data sent from the process controller to the ACT350) always match.

Two types of cyclic blocks are supported on the ACT350:

- Measuring block (IEEE 754 floating point data)
 - Used for numeric values
 - Decimal point and sign included and do not require special data handling

- Status block
 - Used for numeric values
 - Status block data grouped together in 16 bit words.

4.1.3. Acyclic Data

With acyclic messages, the variable can be accessed directly through a unique name or number defined by the control system's acyclic message block.

NOTICE

ACYCLIC DATA IS ALSO REFERRED TO AS ASYNCHRONOUS DATA OR EXPLICIT MESSAGING.

Refer to the applicable SAI Reference Manual **available at www.mt.com/ind-act350-downloads** for more detailed information.

5 Troubleshooting PLC Connectivity

If the ACT350 does not communicate with the PLC, do the following:

- Power cycle the ACT350 to reestablish communications.
- A solid green NW LED on the front panel implies that the ACT350 is on the network and cyclic communication to the PLC is established. A flashing NW LED indicates that the ACT350 is not on the fieldbus network or cyclic communication to the PLC is not established.
- Check LED status of the connection socket. The top LED should be solid green. If the top LED is not solid green, this implies that no hardware connection is seen by the device -check cabling and connector insertions. The bottom LED will blink amber if data is being transferred. If the top LED is solid green, but the bottom LED is not blinking, this implies a configuration issue - either in the ACT350 or the PLC.
- Confirm that the ACT350 can respond to a ping on the network. If it doesn't, check the port settings, wiring and network connections.
- Diagnose and correct specific network error conditions such as IP Address conflicts.
- Confirm that the ACT350 settings for address, format and byte order match those in the PLC and that each ACT350 has a unique address.
- Check the Electronic Keying from in the PLC program. Confirm that the firmware revision of the Ethernet/IP module in the ACT350 is greater than or equal to the firmware revision specified in the ACT350's communication module in the PLC. Change the firmware revision being looked for in the PLC's communication module if necessary.
- Visit the METTLER TOLEDO web page at www.mt.com/ind-act350-downloads to check for other Troubleshooting information.
- Contact METTLER TOLEDO for additional troubleshooting help.

6 Configuration and Maintenance Tools

Two tools can be used for configuration and maintenance of ACT350: Webserver and Setup+™.

6.1. ACT350 Webserver

The ACT350 webserver is a built-in tool and supports the following functions:

- Configuration of the ACT350 Transmitter via web browser, such as IE, Chrome and Safari;
- Access diagnostic and maintenance information for service purposes;

NOTICE

THE WEBSERVER IS AVAILABLE ONLY FOR PROFINET AND EtherNet/IP TYPES: THE PROFIBUS DP VERSION DOES NOT SUPPORT WEBSERVER

6.1.1. PC and ACT350 Setup

NOTICE

THE WEBSERVER IS AVAILABLE FOR UNITS WITH SERIAL NUMBER STARTING FROM B750152347. MAKE SURE THE PC AND ACT350 TRANSMITTER ARE IN THE SAME LOCAL NETWORK.

In order to use the webserver on ACT350, your PC and ACT350 transmitter must be in the same local network. They need to be physically connected on the same network, and have correct IP configurations. The IP configuration of the ACT350 transmitters can be done using the front panel keys. Based on the operation system, the way to set IP configuration of the PC can be different. A PC on Windows 10 for example:

Go to Control Panel\Network and Internet\Network Connections --> select the Ethernet device --> double click "Internet Protocol Version 4 (TCP/IP)"

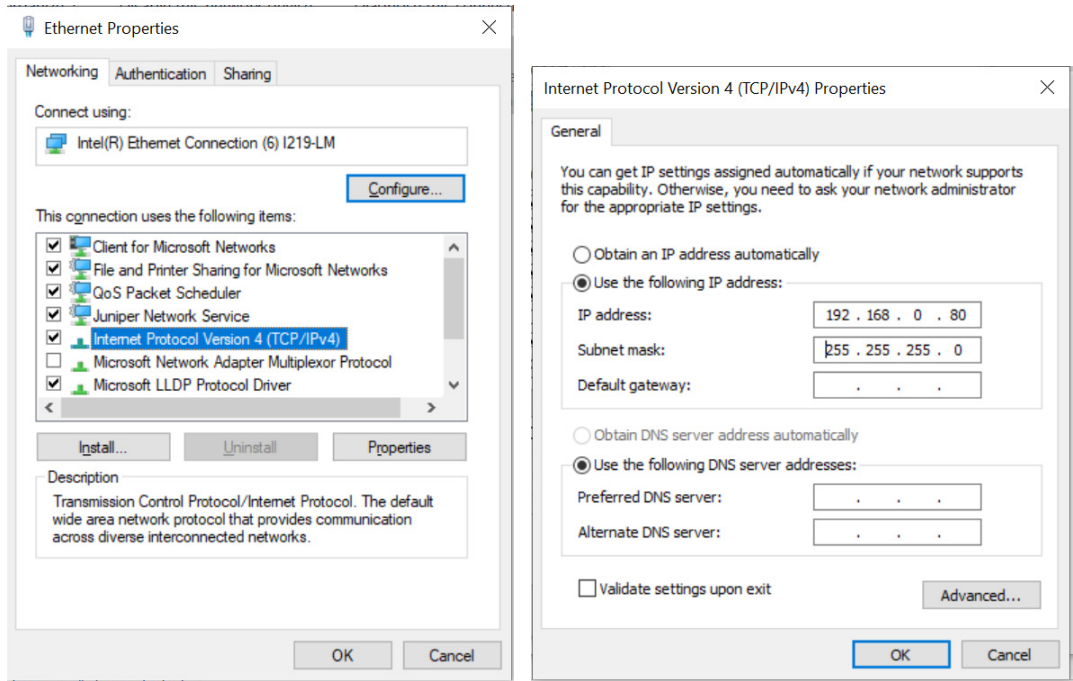

Figure 6-1 Local Area Connection Setting

Typical PC and ACT350 IP configuration:

PC: IP address: 192.168.0.X (X = 0 ~ 255, avoid use 2 if possible, since the default IP address of ACT350 is 192.168.0.2), Subnet Mask: 255.255.255.0

ACT350: IP address: 192.168.0.Y (Y = 0 ~ 255), Subnet Mask: 255.255.255.0

If there are more than one ACT350s on the network, each of them shall have individual "Y".

6.1.2. IE Setup

Internet Options -> Connections -> LAN settings -> Automatically detect settings should be unchecked.

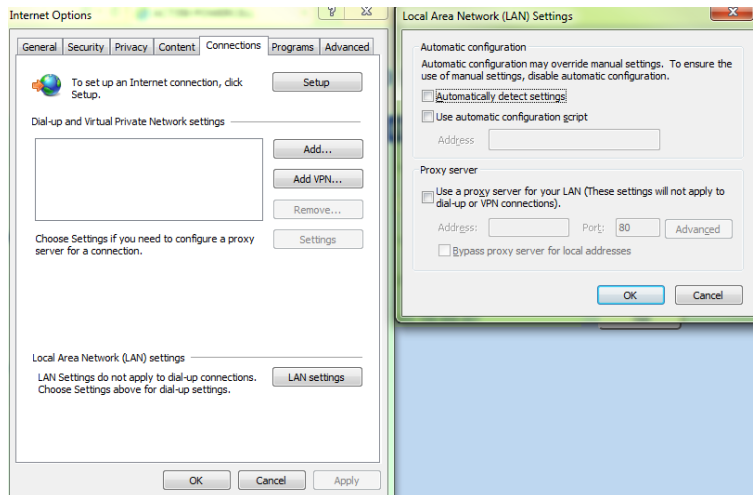

Figure 6-2: IE Setting

By entering the IP address of the ACT350 Transmitter in the web browser, the startup screen of the webserver will be displayed.



Figure 6-3 Webserver Splash Screen

The Webserver only works when the PC is connected to the ACT350 Transmitter. The connection status can be checked in the top right corner "Network state".



Figure 6-4 Webserver Connecting status (Online/Offline)

6.1.3. Webserver Menu Structure

Webserver can be used to configure, maintain or troubleshoot ACT350 transmitters. The functions can be selected from the menu on the left side of the webserver interface. The structure of the menu is featured in the chart below:

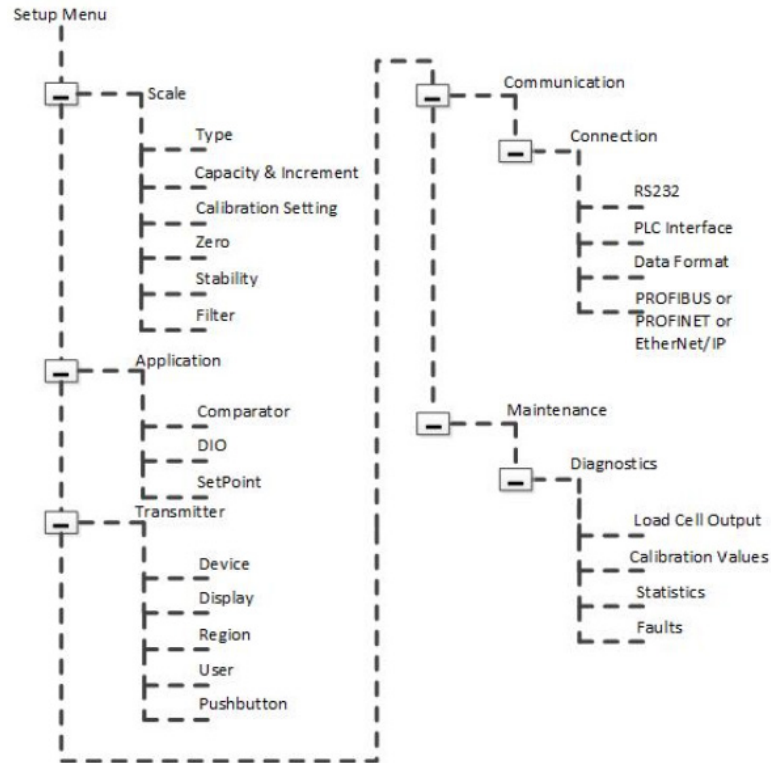

Figure 6-5 Webservice Menu Structure

6.2. Setup+ Configuration Tool

PROFIBUS DP version of the ACT350 transmitter does not support webserver since there is no Ethernet port on the device. Setup+™ software can be used instead.

6.2.1. General Overview



Figure 6-6: Setup+ Splash Screen

Setup+ is a PC tool available online to support the following functions:

- Configuration of the ACT350 Transmitter using local PC
- Save transmitter configuration to a local PC
- Load a saved configuration to other transmitters performing similar applications
- Restore to a 'last known good state' for service purposes
- ACT350 Transmitter software upgrade and maintenance

6.2.2. PC Installation

- Please download the Setup+ installation guide and the Setup+ software from www.mt.com/ind-act350-downloads.

6.2.3. Setup+ User Guide

- Open Setup+ on your PC and click on the **Help** icon in the toolbar to download the **Setup+ User's Guide**.

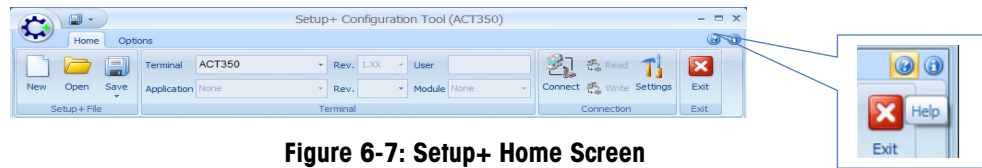

Figure 6-7: Setup+ Home Screen

7 GEO Codes

The GEO code feature provided in the ACT350 transmitter permits calibration readjustment due to changes in elevation or latitude without reapplying test weights. This adjustment assumes a previously accurate calibration was done with the GEO code set properly for that original location and that the GEO code for the new location can be accurately determined. The procedure for using this feature is as follows.

7.1. Original Site Calibration

1. Use the GEO code chart (Table 7-1) on the following pages to determine the GEO code for the current altitude and location at which the scale will be calibrated.
2. Enter that GEO value into the GEO code parameter in setup at **Scale > Calibration**.
3. Immediately after entering the GEO code, perform a zero and span adjustment using accurate test weights.
4. Exit the setup menu tree.
5. The scale can now be used in its new location.

7.2. New Site GEO Code Adjustment

When a terminal is to be reinstalled at a different geographic location, gravitational and altitude changes can be accounted for by following these steps. Note that this procedure is not necessary if an on-site recalibration is performed.

1. Use the GEO code chart (Table 7-1) on the following pages to determine the GEO code for the new altitude and location at which the scale will be used.
2. Enter that GEO value into the GEO code parameter in Setup at **Scale > Calibration**.
3. Immediately after entering the GEO code, exit the setup menu tree. DO NOT perform a normal calibration.

The calibration has now been adjusted for the differences in gravity from the original site of calibration to the new site of use.

- Using the GEO code value for calibration adjustment is not as accurate as re-applying certified test weights and re-calibrating the scale in a new location.

Table 7-1: GEO Adjustment Values

Latitude North or South, in Degrees and Minutes	Height Above Sea Level, in Meters										
	0	325	650	975	1300	1625	1950	2275	2600	2925	3250
	325	650	975	1300	1625	1950	2275	2600	2925	3250	3575
	Height Above Sea Level, in Feet										
	0	1060	2130	3200	4260	5330	6400	7460	8530	9600	10660
1060	2130	3200	4260	5330	6400	7460	8530	9600	10660	11730	
0° 0'–5° 46'	5	4	4	3	3	2	2	1	1	0	0
5° 46'–9° 52'	5	5	4	4	3	3	2	2	1	1	0
9° 52'–12° 44'	6	5	5	4	4	3	3	2	2	1	1
12° 44'–15° 6'	6	6	5	5	4	4	3	3	2	2	1
15° 6'–17° 0'	7	6	6	5	5	4	4	3	3	2	2
17° 10'–19° 2'	7	7	6	6	5	5	4	4	3	3	2
19° 2'–20° 45'	8	7	7	6	6	5	5	4	4	3	3
20° 45'–22° 22'	8	8	7	7	6	6	5	5	4	4	3
22° 22'–23° 54'	9	8	8	7	7	6	6	5	5	4	4
23° 54'–25° 21'	9	9	8	8	7	7	6	6	5	5	4
25° 21'–26° 45'	10	9	9	8	8	7	7	6	6	5	5
26° 45'–28° 6'	10	10	9	9	8	8	7	7	6	6	5
28° 6'–29° 25'	11	10	10	9	9	8	8	7	7	6	6
29° 25'–30° 41'	11	11	10	10	9	9	8	8	7	7	6
30° 41'–31° 56'	12	11	11	10	10	9	9	8	8	7	7
31° 56'–33° 9'	12	12	11	11	10	10	9	9	8	8	7
33° 9'–34° 21'	13	12	12	11	11	10	10	9	9	8	8
34° 21'–35° 31'	13	13	12	12	11	11	10	10	9	9	8
35° 31'–36° 41'	14	13	13	12	12	11	11	10	10	9	9
36° 41'–37° 50'	14	14	13	13	12	12	11	11	10	10	9
37° 50'–38° 58'	15	14	14	13	13	12	12	11	11	10	10
38° 58'–40° 5'	15	15	14	14	13	13	12	12	11	11	10
40° 5'–41° 12'	16	15	15	14	14	13	13	12	12	11	11
41° 12'–42° 19'	16	16	15	15	14	14	13	13	12	12	11
42° 19'–43° 26'	17	16	16	15	15	14	14	13	13	12	12
43° 26'–44° 32'	17	17	16	16	15	15	14	14	13	13	12
44° 32'–45° 38'	18	17	17	16	16	15	15	14	14	13	13

Latitude North or South, in Degrees and Minutes	Height Above Sea Level, in Meters										
	0	325	650	975	1300	1625	1950	2275	2600	2925	3250
	325	650	975	1300	1625	1950	2275	2600	2925	3250	3575
	Height Above Sea Level, in Feet										
	0	1060	2130	3200	4260	5330	6400	7460	8530	9600	10660
1060	2130	3200	4260	5330	6400	7460	8530	9600	10660	11730	
45° 38'–46° 45'	18	18	17	17	16	16	15	15	14	14	13
46° 45'–47° 51'	19	18	18	17	17	16	16	15	15	14	14
47° 51'–48° 58'	19	19	18	18	17	17	16	16	15	15	14
48° 58'–50° 6'	20	19	19	18	18	17	17	16	16	15	15
50° 6'–51° 13'	20	20	19	19	18	18	17	17	16	16	15
51° 13'–52° 22'	21	20	20	19	19	18	18	17	17	16	16
52° 22'–53° 31'	21	21	20	20	19	19	18	18	17	17	16
53° 31'–54° 41'	22	21	21	20	20	19	19	18	18	17	17
54° 41'–55° 52'	22	22	21	21	20	20	19	19	18	18	17
55° 52'–57° 4'	23	22	22	21	21	20	20	19	19	18	18
57° 4'–58° 17'	23	23	22	22	21	21	20	20	19	19	18
58° 17'–59° 32'	24	23	23	22	22	21	21	20	20	19	19
59° 32'–60° 49'	24	24	23	23	22	22	21	21	20	20	19
60° 49'–62° 9'	25	24	24	23	23	22	22	21	21	20	20
62° 9'–63° 30'	25	25	24	24	23	23	22	22	21	21	20
63° 30'–64° 55'	26	25	25	24	24	23	23	22	22	21	21
64° 55'–66° 24'	26	26	25	25	24	24	23	23	22	22	21
66° 24'–67° 57'	27	26	26	25	25	24	24	23	23	22	22
67° 57'–69° 35'	27	27	26	26	25	25	24	24	23	23	22
69° 5'–71° 21'	28	27	27	26	26	25	25	24	24	23	23
71° 21'–73° 16'	28	28	27	27	26	26	25	25	24	24	23
73° 16'–75° 24'	29	28	28	27	27	26	26	25	25	24	24
75° 24'–77° 52'	29	29	28	28	27	27	26	26	25	25	24
77° 52'–80° 56'	30	29	29	28	28	27	27	26	26	25	25
80° 56'–85° 45'	30	30	29	29	28	28	27	27	26	26	25
85° 45'–90° 00'	31	30	30	29	29	28	28	27	27	26	26

A. Trigger Weighing

The trigger weighing application is used to determine the weight value during a dynamic weighing process. The key parameters are the weighing accuracy and throughput rate.

This appendix describes:

- how to use the triggered weighing application on ACT350DIO,
- how to install,
- how to calibrate,
- how to configure the parameters of the application
- how to get the weight value by PLC.

NOTICE

THE TRIGGER WEIGHING MODE IS AVAILABLE ONLY ON THE ACT350DIO VERSION, AS A SPECIFIC WEIGHING FUNCTION.

THERE ARE NO DEDICATED SPECIAL APPROVALS AND CERTIFICATES AVAILABLE FOR ACT350DIO RELATED WITH THIS MODE. ONLY STATIC WEIGHING APPROVALS ARE AVAILABLE.

A.1. Electrical Installation

Regarding the installation, please check the following physical connections:

1. Power Supply: Connect to the DC power source. The range is from 12V DC – 30V DC. Typically 24V DC.
2. Load cell interface: connect to the analog load cell with 4 or 6 wires, and pay special attention to the ESD protection (Ferrite and silicone sleeve). The sensitivity of the load cell should be 1mv/v or 2mv/v.
3. Digital input and output: please connect the signal from the light barrier to the digital input of the ACT350DIO. This is required by the triggered weighing application.
4. PLC interface: use the shield cable to maintain communication quality.

A.2. Trigger Weighing Typical Example

The trigger weighing application is used to determine the weight value during the dynamic weighing process of a weighing object. The key parameters are the weighing accuracy and throughput rate.

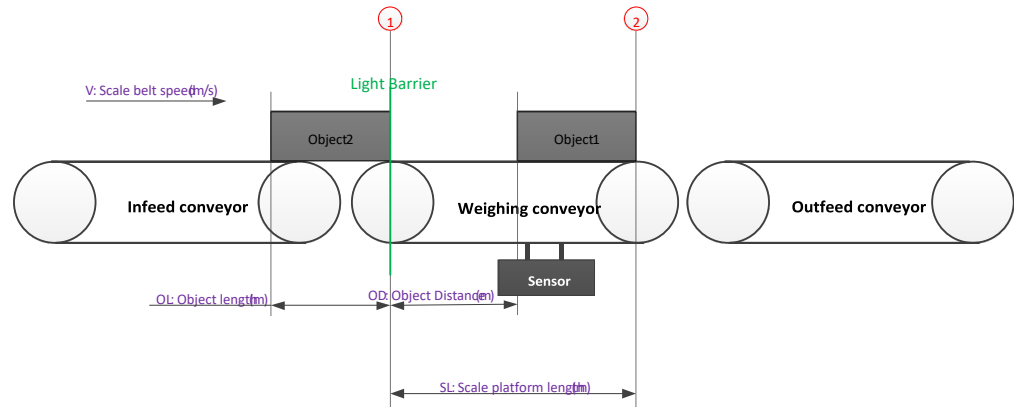

Figure A-1: Trigger Weighing Mode example

Please see Figure A-1 for an example of a typical trigger weighing system:

- Infeed conveyor: moves the weighing object onto the weighing conveyor;
- Weighing conveyor: detects the weighing object approaching the light barrier (①), and starts the weighing process when the whole weighing object is on the scale. The weight of the weighing object is determined before it has left the weighing conveyor (②);
- Outfeed conveyor: moves the weighing object along.

In order to get the best weighing accuracy, the time the weighing object spends on the weighing conveyor should be as long as possible. The system disturbance should also be as small as possible. Both of these factors should be considered along with the the system throughput rate.

The main parameters of the system are:

- Scale belt speed (m/s)
- Scale platform length (m)
- Object distance (m): to keep only one weighing object on the weighing conveyor, otherwise the weighing accuracy will be very poor;
- Object length (m)

NOTICE

SENSOR SIGNAL AND LIGHT BARRIER SIGNAL MUST BE CONNECTED TO ACT350DIO CORRECTLY; OTHERWISE IT IS IMPOSSIBLE TO RUN THE TRIGGER WEIGHING MODE.

A.3. Calibration

Calibration can be performed using the device main menu, Setup+ or the built-in webserver. Before calibration, please configure the scale capacity and scale increment size.

A.4. Configuration of the trigger weighing application

During this configuration process, the PC must connect to the ACT35ODIO via RS232 interface. A serial communication tool, such as HyperTerminal, will be needed since all configuration must be completed by VA commands. See the VA command list in Table A-1.

A.4.1. Change the Weighing Mode

Before using the trigger weighing application, the weighing mode must be configured to "Trigger weight".

No	Send VA Cmd	Receive	Notes
1	LOGON	-	Start VA communication
2	R118	R118 0	Get current weighing mode
3	W118	W118 2	Set the trigger weight mode
4	LOGOF	-	Stop VA communication

A.4.2. Configure the Digital Input Port Dunction

Before using the trigger weighing application, input one must be configured as the start signal for the trigger weighing application.

No	Send VA Cmd	Receive	Notes
1	LOGON	-	Start VA communication
2	R208 R210 R212	R208 0 R210 0 R212 0	Input 1 assignment is: None Input 2 assignment is: None Input 3 assignment is: None
3	W208 4	-	Set the input 1 assignment to: TriggerWeightFront
4	R011	R011 00	Read the status of all input ports
5	LOGOF	-	Stop VA communication

A.4.3. Configure the Parameters of the Trigger Weighing Application

Before using the trigger weighing application, the following parameters must be set: scale belt speed, scale platform length, object distance, object length, time for light barrier occlusion and transparent property.

No	Send VA Cmd	Receive	Notes
1	LOGON	-	Start VA communication

No	Send VA Cmd	Receive	Notes
2	R811 R812 R813 R814 R816 R817	R811 0.000000 R812 0.000000 R813 0.000000 R814 0.000000 R816 0.000000 R817 0	Scale belt speed Scale platform length Object distance Object length Time for light barrier occlusion Is transparent object
3	W811 0.5 W812 1.0 W813 1.0 W814 0.1 W816 4.0 W817 0	- - - - - -	Scale belt speed: 0.5 m/s Scale platform length: 1 m Object distance: 1 m Object length: 0.1 m Time for light barrier occlusion: 4 s Is transparent object: no
4	LOGOF	-	Stop VA communication

A.4.4. Read the Information of the Trigger Weighing Application

A.4.4.1. By VA Commands

It is possible to read out the status of the trigger weighing application, the trigger weighing value and other information by VA commands. Please see the table below:

No	Send VA Cmd	Receive	Notes
1	LOGON	-	Start VA communication
2	R036	R036 0	The flag of new data available
3	R037	R037 0	Object status on weighing scale
4	R038	R038 0	Error message on triggered weight mode
5	R039	R039 0.000000	Latest triggered weight
6	R041	R041 0	Number of triggered weight counts
7	R042	R042 0.000000	Max triggered weight
8	R043	R043 0.000000	Min triggered weight
9	R044	R044 0.000000	Average triggered weight
10	R045	R045 0.000000	Standard deviation of last 20 trigger weights
11	R046	R046 2114	Application status
12	R047	R047 1	Flag of update zero
13	LOGOF	-	Stop VA communication

A.4.4.2. By SAI Commands

It is also possible to read out the status of the trigger weighing application, the trigger weighing value and other information by SAI commands. Please see the table below:

A.4.4.2.1. Status of the trigger weighing application

Read out the status information via the following status block cyclic commands:

Value	Description
23	Alarm, I/O group 1, Customer application group 1

Please see below table for more detail:

Alarm Group

Bit #	Soft Alarm	Description
0	Rate of change error	Product, application or customer defines a weight / time scenario as a system where either the material is not available for filling or a feeding system is not transporting material to the scale (slow fill timeout)
1	Communication error	relates to a device that is connected to a sensor or terminal and the necessary communication is not functioning according to specification
2	Over / under voltage(s)	
3	Weight drift	relates typically to a strain gage sensor that either has a broken bridge or is damaged by water or lightning. The drift weigh vs. time is outside of acceptable tolerances.
4	Breach	the sensors enclosure has been compromised and therefore vulnerable to outside influences such as moisture / water – in most cases a failure will occur if the breach is not corrected or the sensor replaced
5	Calibration expired	Customer / technician determines the maximum number of transactions, or a time limit to occur before a preventative service or recalibration – the alarm will toggle on N+1 weighing transactions
6	-	
7	-	
8	-	
9	-	
10	-	
11	-	
12	-	
13	-	
14	-	

Bit #	Soft Alarm	Description
15	-	

I/O Group 1

Bit #	Data	Description
0	In 1	Status of the input 1
1	In 2	Status of the input 2
2	In 3	Status of the input 3
3	-	
4	-	
5	-	
6	-	
7	-	
8	Out 1	Status of the output 1
9	Out 2	Status of the output 2
10	Out 3	Status of the output 3
11	Out 4	Status of the output 4
12	Out 5	Status of the output 5
13	-	
14	-	
15	-	

Customer application group 1

Bit #	Soft Alarm	Description
0	NewDataAvailable	
1	Ok(Ready for next object)	
2	UpScale	Weighing object is coming onto the scale
3	OnScale	Weighing object is on the scale
4	WeighingStart	Start the weighing or calibration process
5	WeighingOver	End the weighing or calibration process
6	Ok(No error)	There is no error in the weighing process
7	LongObject	Object is too long, and can't be weighed
8	ShortDistance	Distance between two objects is too short, and can't be weighed
9	PhotoOcclusionFront	The light barrier (front) is experiencing occlusion. This should be stopped and the light barrier should be cleared.
10	PhotoOcclusionRear	The light barrier (Rear) is experiencing occlusion. This should be stopped and the light barrier should be cleared.

Bit #	Soft Alarm	Description
11	FlagOfUpdateZero	If this bit is 1, that means the PLC can send the zero command to clear the zero, otherwise it is not possible
12	-	
13	-	
14	-	
15	-	

- Read out the weighing result of the trigger weighing application by acyclic SAI commands, please see below table:

PROFINET

Slot, sub-slot	Index	Description
0, 1	0x4501	Last process weight
0, 1	0x4503	Number of dynamic weighments
0, 1	0x4504	Max dynamic weight
0, 1	0x4505	Min dynamic weight
0, 1	0x4506	Average dynamic weight
0, 1	0x4507	Standard deviation of last 20 dynamic wghmnts

PROFIBUS

Slot	Index	Description
2	0x90	Last process weight
2	0x92	Number of dynamic weighments
2	0x93	Max dynamic weight
2	0x94	Min dynamic weight
2	0x95	Average dynamic weight
2	0x96	Standard deviation of last 20 dynamic wghmnts

ETHERNET/IP

Class, instance	Attribute	Description
0x41A, 01	0x01	Last process weight
0x41A, 01	0x03	Number of dynamic weighments
0x41A, 01	0x04	Max dynamic weight
0x41A, 01	0x05	Min dynamic weight
0x41A, 01	0x06	Average dynamic weight
0x41A, 01	0x07	Standard deviation of last 20 dynamic wghmnts

A.5. VA Commands

A serial communication tool, such as Hyperterminal, can connect with the ACT350DIO to read and write variables per the following examples:

- Read request: R(index#)<CR><LF>
 - Read AD Board Type: R021<CR><LF>
 - Response 1 (valid): R021<SP>1<CR><LF>
 - Read AD Board Type: R021<CR><LF>
 - Response 2 (error): R021<SP>Error: Invalid Request<CR><LF>

- Write request: W(index#)<SP>xxxxx<CR><LF>
 - Write target value : W603<SP>42.75<CR><LF>
 - Response 1: <ACK><CR><LF> (if data is accepted)
 - Response 2: <NAK><CR><LF> (if data or variable is invalid)

Table A-1: Trigger Weighing VA commands

Index	Name	Description	Default	R/W
208	Input 1 Assignment	0 – None 1 – ClearTare 2 – Tare 3 – Zero 4 – Triggered weight_Front 5 – Triggered weight_Rear	0	R/W
210	Input 2 Assignment	Same as Input 1 Assignment	0	R/W
212	Input 3 Assignment	Same as Input 1 Assignment	0	R/W
118	Weighing Mode	0 – Normal 1 – Dynamic 2 – Triggered weight	0	R/W
811	Scale belt speed	Manual Entry – float type, and range is 0 ~ 5, unit: m/s	0	R/W
812	Scale platform length	Manual Entry – float type, and range is 0 ~ 5, unit: m	0	R/W
813	Object distance	Manual Entry – float type, and range is 0 ~ 5, unit: m	0	R/W
814	Object length	Manual Entry – float type, and range is 0 ~ 5, unit: m	0	R/W
816	TimePhotoblock	Manual Entry – float type, and range is 0 ~ 5, unit: s If no configuration, the default value is: 2 * Scale platform length / Scale belt speed	default	R/W

Index	Name	Description	Default	R/W
817	IsTransparent	0 – Non transparent object 1 – Transparent object	0	R/W
036	NewDataAvailable	0 – Not available 1 – Available	0	R
037	Object status on weighing scale	0 – ok 1 – UpScale 2 – OnScale 3 – WeighingStart 4 – WeighingOver	0	R
038	Error message on triggered weight mode	0 – ok 1 – LongObject 2 – ShotDistance 3 – PhotoOcclusion	0	R
039	Latest triggered weight	Latest triggered weight value, float type	0	R
040	Object length	By internal calculated object length, float type	0	R
041	Number of triggered weight counts	By internal calculated number of triggered weight counts, integer type	0	R
042	Max triggered weight	Maximum triggered weight value, float type	0	R
043	Min triggered weight	Maximum triggered weight value, float type	0	R
044	Average triggered weight	Mean triggered weight value, float type	0	R
045	Standard deviation of last 20 trigger weights	Standard deviation of last 20 triggered weight, float type	0	R
046	Application status	The same value as Custom Application Status Bits,Group1 of SAI	0	R
047	Flag of update zero	Be ready to do the update zero work	0	R

B. TCP/IP Communication

TCP/IP communication is a new feature supported by PROFINET or EtherNet/IP versions of the ACT350/ACT350DIO. The user can connect their PC to ACT350 via the socket connection and perform the operations below using the MT-SICS protocol.

- Request the weighing results such as Gross/Tare/Net weight values,
- Remote Zero/Tare/Clear operations,
- Read the Serial Number and FW Revision Number.

B.1. Socket Connection

ACT350 opens port No. 81 for connection. Connect to ACT350 via the IP address and port No. 81. Only one socket connection is allowed. Make sure to close the Webserver of the ACT350 before attempting TCP/IP communication since the Webserver uses a socket connection.

B.2. Introduction to MT-SICS Commands

MT-SICS (METTLER TOLEDO Standard Interface Command Set) is a standardized command set from METTLER TOLEDO. Only the MT-SICS commands listed in Table B-1 are supported by ACT350.

Table B-1: ACT350 MT-SICS Command List

No	Command	Description
1	SIX1	Provide complete weight information to host software, several status flags beside gross, net and tare value
2	TA	Request tare value
3	SI	Request net value
4	Z	Zero the scale.
5	ZI	Zero Immediately
6	T	Tare a stable weight value
7	TI	Tare Immediately
8	TAC	Clear tare value

No	Command	Description
9	I3	Inquiry of FW Revision Number
10	I4	Inquiry of Serial Number

B.2.1. Command Formats of MT-SICS

Each command received by ACT350 is acknowledged by a response to the host. Commands and responses are data strings with a fixed format. Commands sent to the ACT350 comprise one or more characters of the ASCII character set. Enter commands only in uppercase.

The parameters of the command must be separated from one another and from the command name by a space (ASCII 32 dec., in the examples shown in this section, a space is represented as _).

Each command must be terminated by CR LF (ASCII 13 dec., 10 dec.).

The characters CR and LF, which can be inputted using the **ENTER** or **RETURN** key of most entry keypads, are not listed in this description. However, it is essential they be included for communication with ACT350.

B.2.1.1. SICS Command Example

Command to tare the ACT350:

"TA" (The command terminator CR LF is not shown.)

B.2.2. Response Formats

All responses sent by ACT350 to acknowledge the received commands have one of the following formats:

- Response with weight value
- Response without weight value
- Error message

B.2.2.1. Format of the Response with Weight Value

A general description of the response with weight value as follows:

ID__ Status__ Weight Value__Unit CR LF

Table B-2: Response Format

No	Response Characters	Description
1	ID	Response identification
2	_	Space (ASCII 32 dec.)

No	Response Characters	Description
3	Status	Status of the ACT350. Refer to the description of the commands and responses in the sections below
4	Weight Value	Weighing result, shown as a number with 10 digits, including sign directly in front of the first digit. The weight value appears right justified. Preceding zeroes are uppressed with the exception of the zero to the left of the decimal point.
5	Unit	Weight unit displayed
6	CR	Carriage Return (ASCII 13 dec.)
7	LF	Line Feed (ASCII 10 dec.)

B.2.3. Example

Response with a stable weight value of 0.256 kg:

S _ S _ _ _ _ _ 0.256 _ kg

Here CR LF is not shown.

B.2.3.1. Format of the Response without Weight Value

A general description of the response without weight value is as follows:

ID __ Status __ Paramters CR LF

Table B-3: Response Format

No	Response Characters	Description
1	ID	Response identification
2	_	Space (ASCII 32 dec.)
3	Status	Status of the ACT350. Refer to the description of the commands and responses in the sections below
4	Parameters	Command-dependent response code
5	CR	Carriage Return (ASCII 13 dec.)
6	LF	Line Feed (ASCII 10 dec.)

B.2.3.2. Error Messages

ID CR LF

Table B-4: Response Format

No	Response Characters	Description
1	ID	Response identification, could be ES – Syntax error: ACT350 has not recognized the received command. ET – Transmission error: The scale has received a “faulty” command, such as a parity error. EL – Logical error: The command is understood, the parameter is incorrect. EI – Internal Error: The command is understood but cannot be executed at this time.
2	CR	Carriage Return (ASCII 13 dec.)
3	LF	Line Feed (ASCII 10 dec.)

B.3. SIX1 Command

B.3.1. Description

SIX1 is intended to provide complete weighing information for a variety of applications. To provide complete weight information to the terminal or host software, several status flags are provided along with the gross, net and tare values.

B.3.2. Syntax

Reads the parameters from ACT350.

Command: SIX1

Response: SIX1 Sts MinW CoZ Rep Calc PosE StepE MarkE Range TM G N T Unit

B.3.3.

Parameters

Table B-5: SIX1 Command Response

No	Response Characters	Description
1	Sts	Status of the weighing, linked to the net value {Data type: character; encoding ASCII; range of characters see below} The statuses can have the following states: S Stable weight D Dynamic weight (unstable, not accurate) + Overload - Underload / Inclination I Invalid value
2	MinW	Always 0
3	CoZ	Center of zero status {Data type: character; encoding ASCII; range of characters see below.} The center of zero status can have the following states: Z +/- ¼ d around gross zero. N Outside the limits of +/- ¼ d around gross zero
4	Rep	Repeating indicator {Data type: character; encoding ASCII; range of characters see below.} This field indicates, if the value has already been sent or if this is a new weight update (new computed weight value). Valid values are: R Repeated value (was already sent once or more) N New weight update (new computed weight value)
5	Calc	Always R
6	PosE	Always 0
7	StepE	Always 0
8	MarkE	Always 0
9	Range	Always 1
10	TM	Tare mode (no tare, manual tare, measured tare). {Data type: character; encoding ASCII; range of characters see below} Tare modes are: N no tare M measured tare P preset tare

No	Response Characters	Description
11	G	Gross weight value
12	N	Net weight value
13	T	Tare weight value
14	Unit	The displayed unit

B.3.4. Example

Command: SIX1

Response: SIX1 S O Z N R 0 0 0 1 N 0.00 0.00 0.00 kg

B.4. TA Command

B.4.1. Description

TA command is used to request the tare weight value

B.4.2. Syntax

Command: TA

Response:

TA_ A _ TareWeightValue _ Unit to report current Tare weight value.

TA _ I – The command is understood but cannot be executed at this time

TA _ L – Command understood, parameter wrong.

B.4.3. Example

Command: TA

Response: TA _ A _ _ _ _ 10.00 _ kg

B.5. SI Command

B.5.1. Description

SI command is used to request the net weight value.

B.5.2. Syntax

Command: SI

Response:

S _ A – Tare value cleared.

S _ S _ WeightValue _ Unit – Stable weight value.

S _ D _ WeightValue _ Unit – Non-stable weight value.

S _ I – The command is understood but cannot be executed at this time.

S _ + – ACT350 in overload range.

S _ - – ACT350 in underload range.

B.5.3. Example

Command: SI

Response: S _ D _ _ _ _ _ 129.07 _ kg

B.6. Z Command

B.6.1. Description

Z command is used to zero the scale if the weight is stable.

B.6.2. Syntax

Command: Z

Response:

Z _ A – Zero setting performed.

Z _ I – The command is understood but cannot be executed at this time

Z _ + – Upper limit of zero setting range exceeded.

Z _ - – Lower limit of zero setting range exceeded.

B.6.3. Example

Command: Z

Response: Z _ A

B.7. ZI Command

B.7.1. Description

ZI command is used to zero the scale immediately.

B.7.2. Syntax

Command: ZI

Response:

ZI _ A – Zero the scale successfully

ZI _ I – The command is understood but cannot be executed at this time

ZI _ + – Upper limit of tare range exceeded.

ZI _ - – Lower limit of tare range exceeded.

B.7.3. Example

Command: ZI

Response: ZI _ A

B.8. T Command**B.8.1. Description**

T command is used to tare a stable weight value.

B.8.2. Syntax

Command: T

Response:

T_S_WeightValue_Unit – Tare performed. Stability criterion and tare range comply with settings.

Current Tare weight value in current units is returned.

T_ I – Tare not performed

T_+ – Upper limit of tare range exceeded.

T_- – Lower limit of tare range exceeded.

B.8.3. Example

Command: T

Response: T _ S _ _ _ _ _ 100.00_kg

B.9. TI Command**B.9.1. Description**

TI command is used to tare immediately, even if the weight is unstable.

B.9.2. Syntax

Command: TI

Response:

TI _ S _ Weight Value _ Unit – Tare performed, stable tare value.

TI _ D _ Weight Value _ Unit – Tare performed, non-stable tare value.

TI _ I – The command is understood but cannot be executed at this time.

TI _ L – The command is understood, the parameter is wrong.

TI _ + – Upper limit of tare range exceeded.

TI _ - – Lower limit of tare range exceeded.

B.9.3. Example

Command: TI

Response: TI _ D _ _ _ _ 117.57 _ kg

B.10. TAC Command

B.10.1. Description

TAC command is used to clear tare value.

B.10.2. Syntax

Command: TAC

Response:

TAC _ A – Tare value cleared.

TAC _ I – The command is understood but cannot be executed at this time

B.10.3. Example

Command: TAC

Response: TAC _ A

B.11. I3 Command

B.11.1. Description

I3 command is used to request the Firmware Revision Number.

B.11.2. Syntax

Command: I3

Response:

I3 _ A _ 1.00

B.12. I4 Command

B.12.1. Description

I4 command is used to request the ACT350 Serial Number.

B.12.2. Syntax

Command: I4

Response:

I4 _ B123456789

C. Setpoint

C.1. Introduction

SetPoint is a simple application that allows for the inputs and outputs of the ACT350DIO to react to reaching pre-set weights determined by Target Weight, Pre-act and Fine Feed in the below equations.

$$CP1 = \text{Target Weight} - \text{Pre-act} - \text{Fine Feed}$$

$$CP2 = \text{Target Weight} - \text{Pre-act}$$

Fine Feed could be zero. In this case, SetPoint works in single speed mode. The Fast Output is disabled, only Fine Output works.

The Source is used to determine which value, Displayed Weight or Gross Weight, is compared to CP1 and CP2. The comparison result and Latch option determine the status of Fast Output and Fine Output. The Mode parameter determines how Fast Output and Fine Output work.

Table C- 1: SetPoint Settings

Mode	Options are either Concurrent or Independent
Source	Select whether the Gross Weight or Displayed Weight will be used as the source value to be compared to the target weight
Latch	Set to be either enabled or disabled. If enabled, SetPoint output is latched once the weight reaches CP2. The latch is cleared by starting the SetPoint application.
Target Weight	Set the target weight.
Pre-act	Weight of material expected to be added after the Fine Feed output goes FALSE.
Fine Feed	This parameter is used together with Target Weight and Pre-act to define the CP1.

C.2. Concurrent Mode

When Source is set to Gross Weight, two Outputs of Discrete IO are set respectively as Fast Output and Fine Output and gross weight is below CP1, both Fast and Fine Outputs are TRUE. The controlled valves in the user's equipment are open so the material filling speed is the fastest. Then when gross weight increases to hit CP1, Fast Output switches to FALSE and Fine Output remains TRUE until CP2 is reached. Both Fast and Fine Outputs are FALSE at this point and the

corresponding valves are closed. The material filling is stopped. The whole process is shown in Figure C- 1.

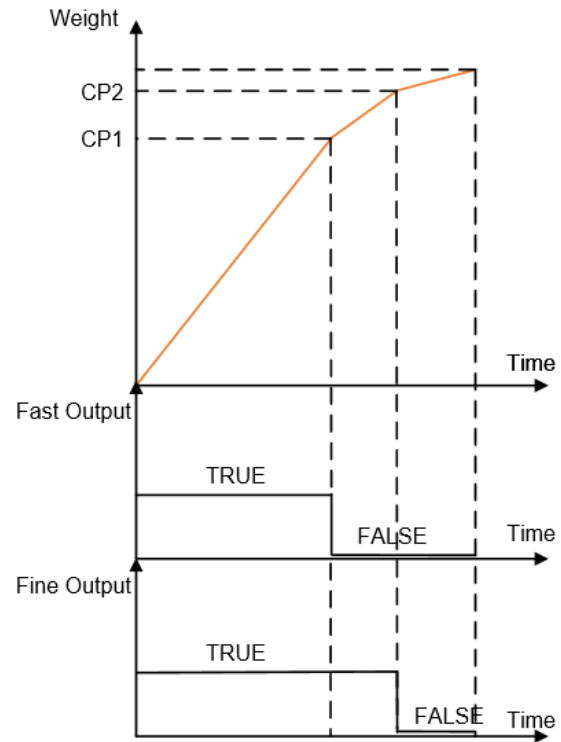

Figure C- 1: Concurrent Mode

C.3. Independent Mode

In this mode the Fast Output and Fine Output will be TRUE sequentially. Figure C- 2 shows the difference to Concurrent Mode.

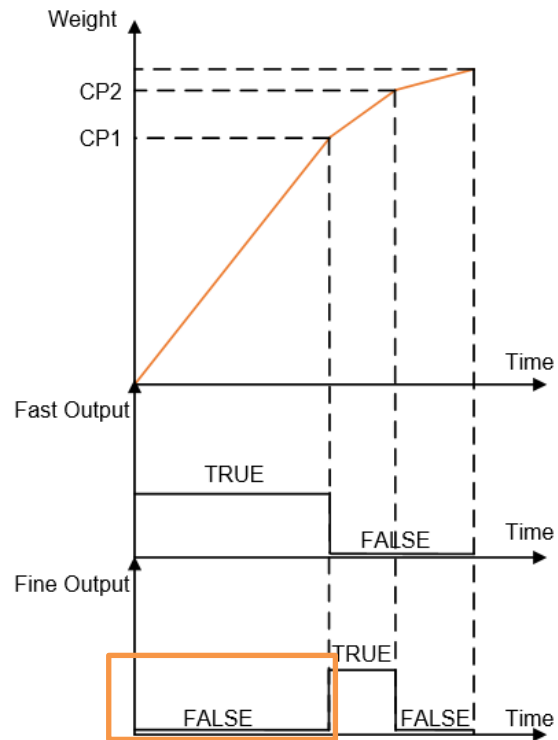

Figure C- 2: Independent Mode

C.4. Latch

When Latch is enabled, once the weight is above CP2, the DIO Outputs are latched at FALSE regardless of further weight changes, e.g. weight decreases to be less than CP2 or even CP1. The FALSE status remains until a Start/Resume SetPoint signal is triggered via a Discrete IO input.

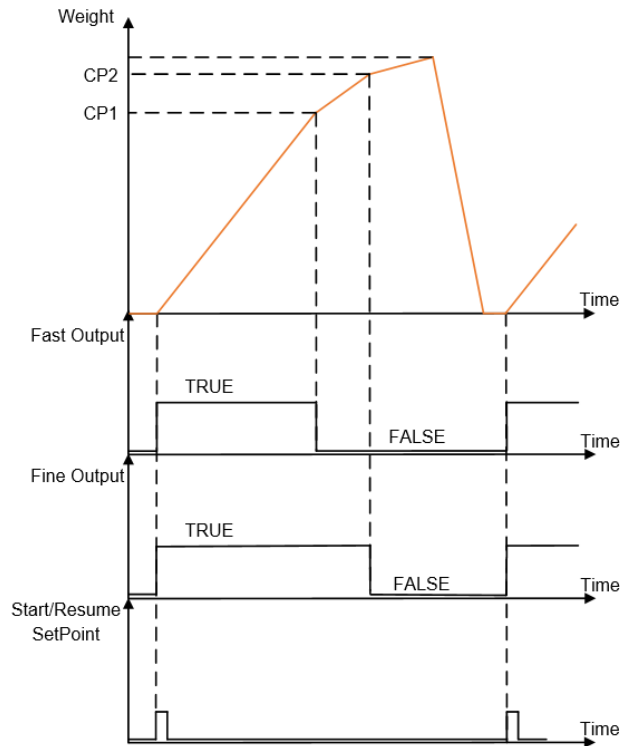

Figure C- 3: Latch Enabled with Start/Resume Input

The Abort SetPoint application input signal can be used to pause the SetPoint process. In this case, the Fast and Fine Outputs will change to FALSE regardless of the comparison result between weight and CP1/CP2. A Start/Resume SetPoint signal is required to resume the process.

When Latch is Disabled, Start/Resume SetPoint and Abort SetPoint application signal are ignored. The Fast and Fine Outputs are only determined by the comparison result between weight and CP1/CP2.

METTLER TOLEDO Service

To protect your METTLER TOLEDO product's future:

Congratulations on choosing the quality and precision of METTLER TOLEDO. Proper use according to these instructions and regular calibration and maintenance by our factory-trained service team ensure dependable and accurate operation, protecting your investment. Contact us about a METTLER TOLEDO service agreement tailored to your needs and budget.

We invite you to register your product at www.mt.com/productregistration so we can contact you about enhancements, updates and important notifications concerning your product.

www.mt.com

For more information

Mettler-Toledo, LLC

1900 Polaris Parkway
Columbus, OH 43240
Phone 800 438 4511
Fax 614 438 4900

© 2021 Mettler-Toledo, LLC
30303895 Rev. 04, 06/2021



30303895