

METTLER TOLEDO



IND780

Q.iMPACT

Terminal

Installation Manual

www.mt.com

64068656
(01/2010) R00

© METTLER TOLEDO 2010

No part of this manual may be reproduced or transmitted in any form or by any means, electronic or mechanical, including photocopying and recording, for any purpose without the express written permission of METTLER TOLEDO.

U.S. Government Restricted Rights: This documentation is furnished with Restricted Rights.

Copyright 2010 METTLER TOLEDO. This documentation contains proprietary information of METTLER TOLEDO. It may not be copied in whole or in part without the express written consent of METTLER TOLEDO.

METTLER TOLEDO reserves the right to make refinements or changes to the product or manual without notice.

COPYRIGHT

METTLER TOLEDO® is a registered trademark of Mettler-Toledo, Inc. All other brand or product names are trademarks or registered trademarks of their respective companies.

METTLER TOLEDO RESERVES THE RIGHT TO MAKE REFINEMENTS OR CHANGES WITHOUT NOTICE.

FCC Notice

This device complies with Part 15 of the FCC Rules and the Radio Interference Requirements of the Canadian Department of Communications. Operation is subject to the following conditions: (1) this device may not cause harmful interference, and (2) this device must accept any interference received, including interference that may cause undesired operation.

This equipment has been tested and found to comply with the limits for a Class A digital device, pursuant to Part 15 of FCC Rules. These limits are designed to provide reasonable protection against harmful interference when the equipment is operated in a commercial environment. This equipment generates, uses, and can radiate radio frequency energy and, if not installed and used in accordance with the instruction manual, may cause harmful interference to radio communications. Operation of this equipment in a residential area is likely to cause harmful interference in which case the user will be required to correct the interference at his or her expense.

◀ Declaration of Conformity is located on the documentation CD.

NOTE ON FIRMWARE REVISIONS

This manual describes features and functions of the IND780 terminal with version 6.1.08 firmware. Terminals with version 6.1.01 firmware or lower will differ in some areas. The following lists indicate the key differences between versions:

- New in version 5.1 – Continuous Extended Output; enhanced SICS scale interface to support WM/WMH, 4-Series and Excellence bases; Ethernet Terminal Clustering; ID and Prompt sequences; serial input for text entry; remote SQL Server Database Access; Modbus TCP interface; DeviceNet™ interface; Chinese language support; support for Axle-780 and Com-780.
- New in version 6.1.01 – Support for SICS levels 2 and 3; revised CalFREE™ functionality; additional display and keyboard language options; DHCP option added for Ethernet/IP and Modbus TCP interfaces; External Diagnostics Load Cell Symmetry page; addition of Watchdog Timer function.
- New in version 6.1.08 – Support for POWERCELL PDX load cells, MT Service View for PDX Diagnostics, PDX Performance Log.

RoHS Compliance Statement.

- The majority of our products fall within categories 8 and 9. Those categories currently do not fall within the scope of the Directive 2002/95/EG (RoHS) of January 27, 2003. If our products are intended for use in other products which themselves fall within the scope of the RoHS Directive, compliance requirements have to be separately negotiated contractually.
- Those products which fall within categories 1-7 and 10 will be in compliance with the EU RoHS Directive from no later than July 1, 2006.
- If it is not possible for technical reasons to replace any non-RoHS-compliant substances in any of the above products as required, we plan to inform our customers in a timely manner

Statement regarding harmful substances.

- We do not make direct use of harmful materials such as asbestos, radioactive substances or arsenic compounds. However, we purchase components from third party suppliers, which may contain some of these substances in very small quantities.

FOLD THIS FLAP FIRST



NO POSTAGE
NECESSARY
IF MAILED IN THE
UNITED STATES

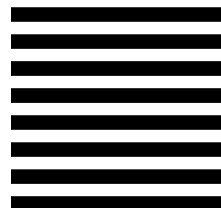

POSTAGE WILL BE PAID BY ADDRESSEE



Mettler-Toledo, Inc.
Quality Manager - MTWT
P.O. Box 1705
Columbus, OH 43216
USA



Please seal with tape

PRECAUTIONS

- READ this manual BEFORE operating or servicing this equipment and FOLLOW these instructions carefully.
- SAVE this manual for future reference.

	<p style="text-align: center;"> WARNING!</p> <p>FOR CONTINUED PROTECTION AGAINST SHOCK HAZARD CONNECT TO PROPERLY GROUNDED OUTLET ONLY. DO NOT REMOVE THE GROUND PRONG.</p>
-----------------------------------------------------------------------------------	----------------------------------------------------------------------------------------------------------------------------------------------------------------------------------------------------------------------------------------------------------------------------

	<p style="text-align: center;"> WARNING!</p> <p>NOT ALL VERSIONS OF THE IND780 ARE DESIGNED FOR USE IN HAZARDOUS (EXPLOSIVE) AREAS. REFER TO THE DATA PLATE OF THE IND780 TO DETERMINE IF A SPECIFIC TERMINAL IS APPROVED FOR USE IN AN AREA CLASSIFIED AS HAZARDOUS BECAUSE OF COMBUSTIBLE OR EXPLOSIVE ATMOSPHERES. THE IND780 HARSH TERMINAL IS NOT MARKED FOR USE IN AREAS CLASSIFIED AS DIVISION 2 OR ZONE 2/22.</p>
-----------------------------------------------------------------------------------	--------------------------------------------------------------------------------------------------------------------------------------------------------------------------------------------------------------------------------------------------------------------------------------------------------------------------------------------------------------------------------------------------------------------------------------------------------------------------------------------------------------------------

	<p style="text-align: center;"> WARNING!</p> <p>IN ORDER TO INSTALL THE DIVISION 2 APPROVED IND780 TERMINAL UTILIZING THE U.S. APPROVAL, METTLER TOLEDO CONTROL DRAWING 174020R MUST BE FOLLOWED WITHOUT EXCEPTION. IN ORDER TO INSTALL THE CATEGORY 3 MARKED IND780 TERMINAL UTILIZING THE EUROPEAN APPROVAL, THE DEMKO APPROVAL CERTIFICATE 07ATEX0520819X AND ALL LOCAL REGULATIONS MUST BE FOLLOWED WITHOUT EXCEPTION. FAILURE TO DO SO COULD RESULT IN BODILY HARM AND/OR PROPERTY DAMAGE. REFER TO THE IND780 DIVISION 2 AND ZONE 2/22 INSTALLATION GUIDE 64063214 FOR ADDITIONAL INFORMATION.</p>
-------------------------------------------------------------------------------------	---------------------------------------------------------------------------------------------------------------------------------------------------------------------------------------------------------------------------------------------------------------------------------------------------------------------------------------------------------------------------------------------------------------------------------------------------------------------------------------------------------------------------------------------------------------------------------------------------------------------------------------------------------------------------------------------------------

	<p style="text-align: center;"> WARNING!</p> <p>IF THE KEYBOARD, DISPLAY LENS OR ENCLOSURE IS DAMAGED ON A DIVISION 2 APPROVED OR CATEGORY 3 MARKED IND780 TERMINAL THAT IS USED IN A DIVISION 2 OR ZONE 2/22 AREA, THE DEFECTIVE COMPONENT MUST BE REPAIRED IMMEDIATELY. REMOVE AC POWER IMMEDIATELY AND DO NOT REAPPLY AC POWER UNTIL THE DISPLAY LENS, KEYBOARD OR ENCLOSURE HAS BEEN REPAIRED OR REPLACED BY QUALIFIED SERVICE PERSONNEL. FAILURE TO DO SO COULD RESULT IN BODILY HARM AND/OR PROPERTY DAMAGE.</p>
-------------------------------------------------------------------------------------	-------------------------------------------------------------------------------------------------------------------------------------------------------------------------------------------------------------------------------------------------------------------------------------------------------------------------------------------------------------------------------------------------------------------------------------------------------------------------------------------------------------------------------------------------------------------------------------------------------------------------

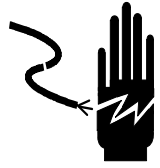

WARNING!

WHEN THIS EQUIPMENT IS INCLUDED AS A COMPONENT PART OF A SYSTEM, THE RESULTING DESIGN MUST BE REVIEWED BY QUALIFIED PERSONNEL WHO ARE FAMILIAR WITH THE CONSTRUCTION AND OPERATION OF ALL COMPONENTS IN THE SYSTEM AND THE POTENTIAL HAZARDS INVOLVED. FAILURE TO OBSERVE THIS PRECAUTION COULD RESULT IN BODILY HARM AND/OR PROPERTY DAMAGE.



CAUTION

BEFORE CONNECTING/DISCONNECTING ANY INTERNAL ELECTRONIC COMPONENTS OR INTERCONNECTING WIRING BETWEEN ELECTRONIC EQUIPMENT ALWAYS REMOVE POWER AND WAIT AT LEAST THIRTY (30) SECONDS BEFORE ANY CONNECTIONS OR DISCONNECTIONS ARE MADE. FAILURE TO OBSERVE THESE PRECAUTIONS COULD RESULT IN DAMAGE TO OR DESTRUCTION OF THE EQUIPMENT AND/OR BODILY HARM.



CAUTION

OBSERVE PRECAUTIONS FOR HANDLING ELECTROSTATIC SENSITIVE DEVICES.

IND780

Q.iMPACT

Terminal



ServiceXXL
Tailored Services

Essential Services for Dependable Performance

Congratulations on choosing the quality and precision of METTLER TOLEDO. Proper use of your new equipment according to this Manual and regular calibration and maintenance by our factory-trained service team ensures dependable and accurate operation, protecting your investment. Contact us about a ServiceXXL agreement tailored to your needs and budget. Further information is available at www.mt.com/serviceXXL.

There are several important ways to ensure you maximize the performance of your investment:

1. **Register your product:** We invite you to register your product at www.mt.com/productregistration so we can contact you about enhancements, updates and important notifications concerning your product.
2. **Contact METTLER TOLEDO for service:** The value of a measurement is proportional to its accuracy – an out of specification scale can diminish quality, reduce profits and increase liability. Timely service from METTLER TOLEDO will ensure accuracy and optimize uptime and equipment life.
 - a. **Installation, Configuration, Integration and Training:** Our service representatives are factory-trained, weighing equipment experts. We make certain that your weighing equipment is ready for production in a cost effective and timely fashion and that personnel are trained for success.
 - b. **Initial Calibration Documentation:** The installation environment and application requirements are unique for every industrial scale so performance must be tested and certified. Our calibration services and certificates document accuracy to ensure production quality and provide a quality system record of performance.
 - c. **Periodic Calibration Maintenance:** A Calibration Service Agreement provides on-going confidence in your weighing process and documentation of compliance with requirements. We offer a variety of service plans that are scheduled to meet your needs and designed to fit your budget.

Contents

Chapter 1.0 Introduction	1-1
IND780 Q.iMPACT	1-1
Overview	1-1
Terminology	1-1
Process Variations	1-2
Role of Q.i in Process Control	1-3
Q.i Features	1-3
Q.i System Capabilities	1-4
IND780 Q.iMPACT Hardware	1-4
IND780 Terminal Models	1-4
Creating a Q.iMPACT Terminal	1-5
IND780 Q.iMPACT Model Identification	1-7
IND780 Q.iMPACT Terminal Specifications	1-8
Physical Dimensions	1-8
Specification table	1-9
System Hardware	1-10
Main PCB	1-10
Scale Bases	1-11
Flow Meter Interface Board	1-11
Options	1-13
TaskExpert™	1-14
Q.i Material Transfer Control Strategy	1-14
Overview	1-14
Material Paths	1-16
Examples of IND780 Q.i Systems	1-19
IND780-based Q.iMPACT Systems	1-19
Components of an IND780 Q.iMPACT System	1-22
Communicating with the IND780 Q.iMPACT Terminal	1-22
Terminal Control Panel	1-23
Q.i Configuration Tool	1-23
Web Pages	1-24
IND780 Q.iMPACT/Host Controller Communications	1-24
Chapter 2.0 Installation	2-1
Precautions	2-1
Unpacking and Inspection	2-2
Opening the Enclosure	2-3
Panel Mount Enclosure	2-3
Harsh Enclosure	2-3
Mounting the Terminal	2-4
Panel Mount Enclosure	2-4

Harsh Enclosure	2-6
Attaching the Enclosure to the Brackets.....	2-8
Ferrites and Option Board Cabling	2-12
Ferrites	2-12
Option Board Cabling	2-13
Harsh Enclosure Cable Glands and Cable Assignments.....	2-14
Harsh Enclosure Cable Openings.....	2-15
Installing Cables	2-16
Main PCB.....	2-18
Main Board Wiring Connections	2-18
Switch Settings	2-22
Master Reset Button	2-23
LED Interpretation.....	2-24
Option Boards.....	2-25
Configuration and Connection of Options	2-25
Analog Load Cell	2-27
POWERCELL PDX	2-31
Flow Meter Interface	2-39
Discrete I/O (Input/Output)	2-42
IDNet	2-46
Serial Option Board	2-47
PLC Interface Modules	2-49
DeviceNet Connections	2-49
PROFIBUS Connections (Harsh Enclosure).....	2-50
PROFIBUS Connections (Panel Mount Enclosure)	2-51
ControlNet Interface	2-52
Ethernet / IP and Modbus TCP Interface	2-53
Rockwell (Allen Bradley) RIO Connections	2-54
Sealing the Enclosure	2-55
Panel Enclosure Sealing	2-56
Harsh Enclosure Sealing.....	2-57

Introduction

IND780 Q.iMPACT

Overview

Congratulations and thank you for purchasing the IND780 Q.iMPACT terminal as your material transfer controller. Q.iMPACT is a unique and advanced application package for the IND780 terminal, engineered exclusively for:

- Feed measurement
- Feed management
- Feed cutoff control

The IND780 Q.iMPACT is a successor to the JAGXTREME[®]-based Q.iMPACT. The second generation Q.i combines years of material transfer application excellence with the processing power, user interface advances and TaskExpert[™] programming flexibility found in the IND780 terminal.

This manual provides an overview of the IND780 Q.iMPACT terminal, and instructions for setup, maintenance and troubleshooting.

Note: For all IND780 information not specifically Q.iMPACT-related, please refer to the IND780 **Installation Guide**, **User's Guide** and **Technical Manual**, provided on the documentation CD-ROM.

Terminology

As you proceed through this and other Q.iMPACT documentation, the following product terms will be used:

- **IND780** refers to the standard hardware terminal. You may be asked to reference the standard IND780 documentation if the subject matter applies directly.
- **Q.i780** refers to the Q.iMPACT software and firmware designed to function with the IND780 hardware terminal. This is also referred to as an application Pac for the IND780.
- **IND780 Q.iMPACT** refers to the combination of the IND780 hardware terminal with the Q.iMPACT software and firmware application.

Q.i is short for **Q.iMPACT**, which is short for **Quantum Impact**. Each of these has a similar meaning:

	Quality Product Improvement
+	Quicker Ingredient Addition
+	Quantifiable Results
=	Quantum Impact

“Material Transfer” is one of many terms used to describe the process phase, or manufacturing step, that moves a material from one location to another. The following processes are all types of material transfer, each of which can be optimized using the Q.i technology:

Filling	Single movement of a specified amount of product from one single location to another location
Dosing	Single movement of a specified amount of product from one location into a continuous process
Formulation	Multiple movements of specified amounts of products from various locations into a single location
Blending	Multiple movements of specified amounts of products from various locations into a single location, plus an additional mixing phase
Batching	Multiple movements of specified amounts of products from various locations into a single location plus multiple additional process phases, such as heating, cooling, waiting, mixing, agitating, dumping, etc.

Many additional terms and definitions can be found in the **Glossary** provided in Appendix F of this manual.

Process Variations

A critical manufacturing challenge is to compensate rapidly and accurately for dynamic variations that always exist in a material feed process. These process variations contribute to material waste, inconsistencies in quality, and reduced throughput. Q.i is able to respond in real time to many different process variations, including (but not limited to):

- Variability caused by raw material inconsistency:
 - Material variation between various suppliers or lots
 - Moisture content in the material
 - Material viscosity changes due to temperature
- Variability generated by pumps, valves and Control Systems, that result in flow rate changes and valve closure times
- Material head pressure variation

Role of Q.i in Process Control

Q.iIMPACT works together with your PLC or DCS system to manage and control your process. Q.iIMPACT is dedicated to time-critical material feed, material measurement, material management and material cut-off control functions, freeing the host system's processing power for other tasks.

Taking advantage of distributed control architecture, IND780 Q.iIMPACT is engineered to orchestrate the entire material transfer control process. Q.i bundles and moves the time-critical material transfer functions into the IND780 terminal, which takes control of the material transfer closer to the actual process.

To accomplish this, each IND780 Q.iIMPACT terminal monitors measurement information directly from field devices including scales, load cell systems or flow meters. Because Q.i has direct control of the final control element (FCE), it can time the feed cut-off to assure on-target accuracy.

Q.i Features

As a professionally-engineered material transfer package, each Q.i terminal is fully configurable, documented, supported and deployed globally. Depending on the options selected for the application, the Q.i terminal combines powerful feed algorithms with best-practice material feed features, including:

- K1 predictive adaptive control algorithm
- K2 predictive adaptive control algorithm
- Spill only algorithm
- Dump-to-Empty control algorithm
- Task Expert function block programming
- Material type (Gain-in-weight/Loss-in-weight)
- Control target management (fixed bias)
- Target type (absolute, additive)
- Tolerance check
- Pre-feed condition checks (stable scale, vessel overflow)
- Flow alarm management
- Drain time management
- Instrument zero shift management
- Interface driver for data communication between instrument and controller
- Abnormal situation management
- Reasonableness checking
- Hand add
- Slow Step Timer
- Command states (status, error handling)
- Material feed states (status, error handling, overflow)
- Weigh/flow digital filtering
- Diagnostics
- Multiple Modes (Setup, Manual, Automatic and Maintenance)
- Reset Capability
- Group feed
- Estimated time to complete
- Post-feed check and report (for accurate & reliable data)
- Overlapping feed management
- Enhanced 2 speed feed control
- Instrument cross check maintenance
- Standard and Enhanced communication modes
- Up to 999 material paths
- Clustering capability (up to 20 terminals, 198 channels maximum)

Q.i System Capabilities

The IND780 Q.iMPACT system can accommodate the following:

- 6 Option board slots in one IND780 Q.iMPACT Terminal:
 - 4 Scale or Load Cell interfaces per IND780 Q.iMPACT
 - 6 Flow Meter Interface Boards (for 12 flow meters) per IND780 Q.iMPACT
 - Combination of 4 Scale or Load Cells and 2 Flow Meter Interface Boards (4 flow meters)
- Space for 1 PLC/DCS interface board – select from EtherNet/IP™, ControlNet and PROFIBUS® DP; for limited connectivity, Modbus TCP, DeviceNet™ and Allen-Bradley RIO may also be used.
- 20 IND780 Q.iMPACT Terminals in one cluster, with remote console, data and interface sharing
- 198 Equipment Channel Modules
- 12 Equipment Channel Modules per Bridge Terminal using the Enhanced Q.i Message Interface
- 24 Equipment Modules per Bridge Terminal using the Classic Qi Message Interface
- 198 Concurrent Phases
- 999 Material Paths

IND780 Q.iMPACT Hardware

IND780 Terminal Models

The Q.i780 application is available in the IND780 IP69K harsh environment or panel mount IND780 enclosures with color display.



Figure 1-1: IND780 Harsh Environment Enclosure, Desktop or Wall-Mount

Creating a Q.iMPACT Terminal

The intrinsic hardware security key feature found within every IND780 enables the Q.i780 application.



Figure 1-2: IND780 Hardware Key Socket on Mother Board

There are two ways to create an IND780 Q.iMPACT terminal:

- The Q.i780 application can be purchased with a new IND780, installed, tested and labeled from the factory.
- The Q.i780 application hardware security key can be purchased separately as an upgrade to an existing IND780 terminal.

Both approaches produce the same result. There are no differences in exterior appearance between an IND780 and an IND780 Q.iMPACT.

Determining the Terminal Type

The simplest way to determine the type of IND780 is to access its information recall screens:

1. From the home screen (Figure 1-3), press the INFORMATION RECALL softkey  (typically in the second row of softkeys).

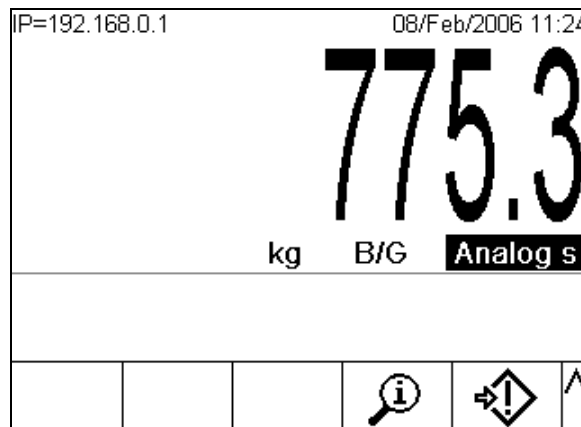

Figure 1-3: IND780 Home Screen Showing Information Recall Softkey

2. The information recall screen will display.

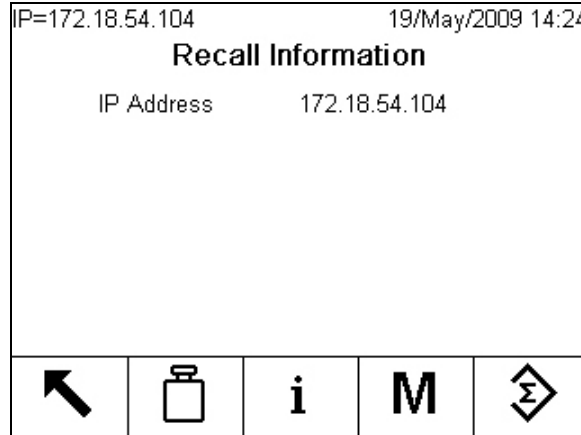

Figure 1-4: System Recall Information Screen

3. Press the INFORMATION softkey **i**.
4. Scroll down using the DOWN arrow key. In the ID column of the information screen, one of the following will appear, indicating that the terminal is a Q.iMPACT IND780:
 - 780Qi+xLic (where x indicates the number of PAC Licenses, 1 to 12)

Upgrade Note

When upgrading to Q.i 780 from a standard IND780 terminal, check any installed option boards against the list of boards compatible with Q.i780, provided in the **Options** section on page 1-13. Once the IND780 is transformed into an IND780 Q.iMPACT, only the option boards listed will be recognized by the Q.i780 application.

Also, please refer to Figure 1-5 for the appropriate slot locations for option boards in an IND780 Q.iMPACT terminal.

IND780 Q.iIMPACT Model Identification

The IND780 model number is located on the data plate on the back of the terminal along with the serial number. Refer to this data plate to verify the IND780 Q.iIMPACT that was ordered.

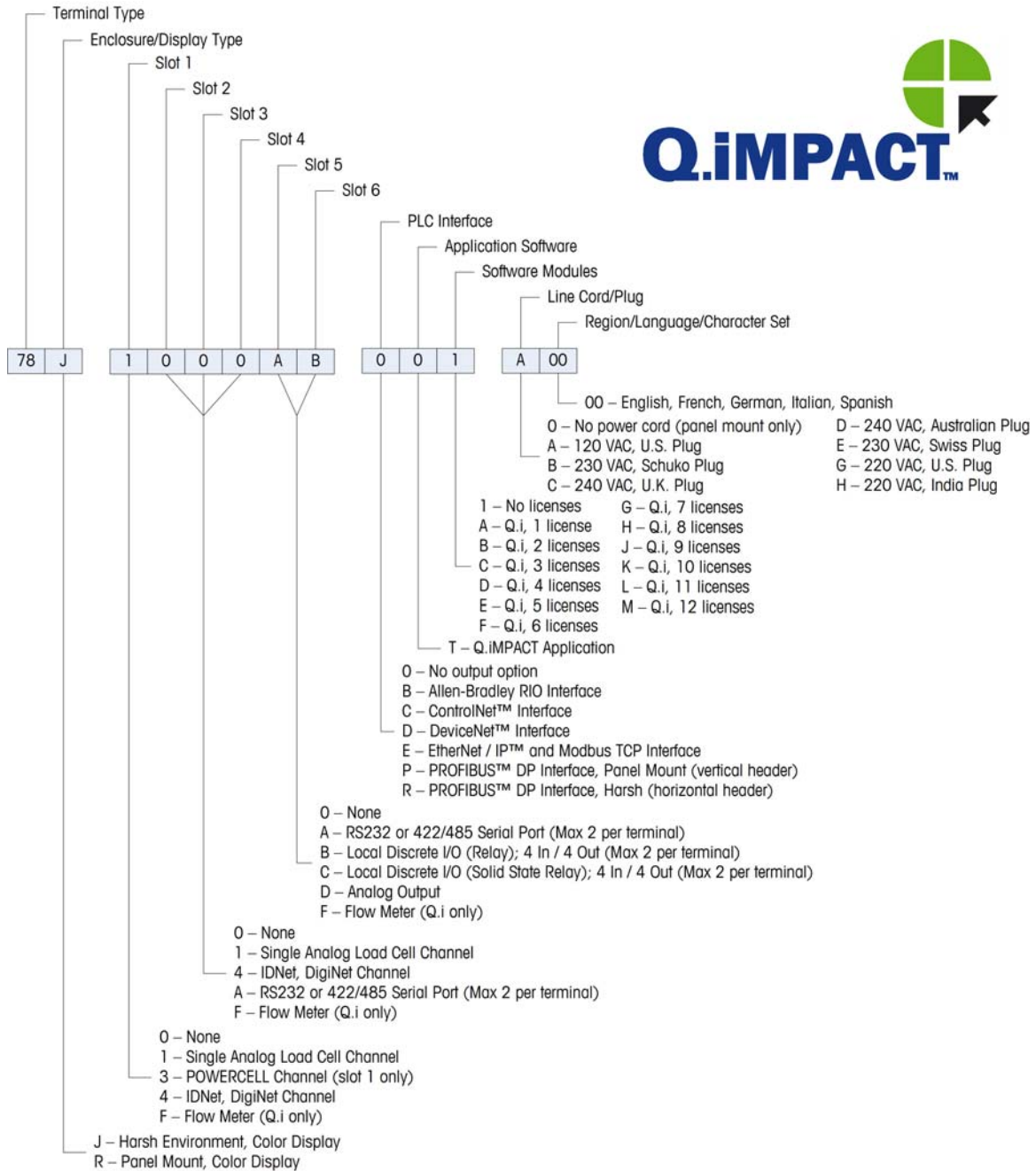

Figure 1-5: IND780 Q.iIMPACT Configurations

IND780 Q.iIMPACT Terminal Specifications

Physical Dimensions

The physical dimensions of the panel mount and harsh environment IND780 terminals are shown in Figure 1-6, Figure 1-7 and Figure 1-8. All measurements are given in inches and [mm].

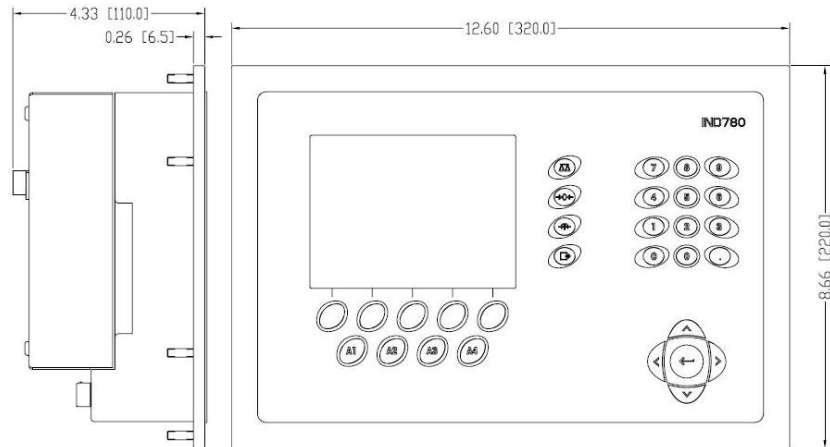

Figure 1-6: IND780 Panel Mount Terminal Dimensions

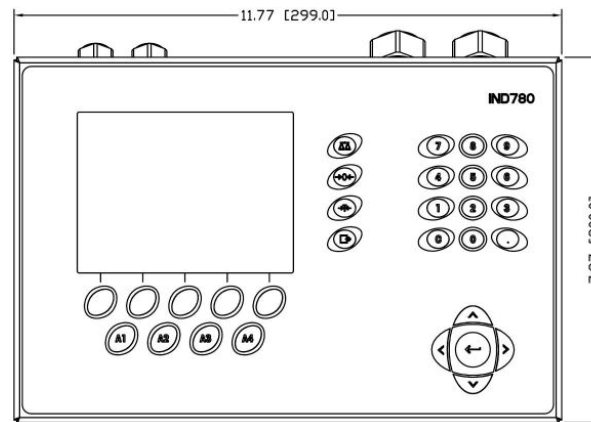

Figure 1-7: IND780 Harsh Enclosure Terminal Dimensions, Front

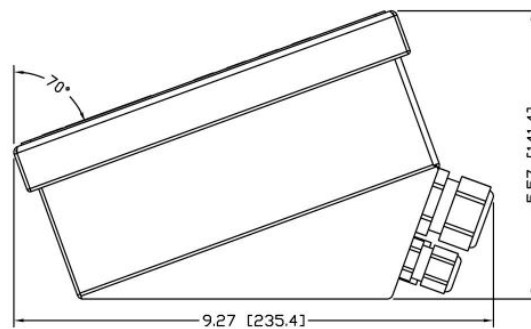

Figure 1-8: IND780 Harsh Enclosure Terminal Dimensions, Side

Specification table

The IND780 terminal conforms to the specifications listed in Table 1-1.

Table 1-1: IND780 Specifications

IND780 Specifications	
Enclosure Type	Panel Mount – stainless steel front panel
	Harsh environment desk/wall/column-mount – type 304 L stainless steel enclosure
Dimensions (l × w × d)	Panel Mount: 320 mm × 220 mm × 110 mm (12.6 in. × 8.7 in. × 4.3 in.)
	Harsh Environment: 299 mm × 200 mm × 141 mm (11.8 in. × 7.9 in. × 5.6 in.)
Shipping Weight	5 kg (11 lb)
Environmental Protection	Panel Mount front panel sealing provides Type 4x and Type 12 protection – comparable to IP65 rating
	Harsh Environment meets IP69K requirements
Operating Environment	The terminal (both enclosure types) can be operated at temperatures ranging from -10° to 40° C (14° to 104°F) at 10% to 95% relative humidity non-condensing
Hazardous Areas	Not all versions of the IND780 can be operated in areas classified as Hazardous by the National Electrical Code (NEC) because of the combustible or explosive atmospheres in those areas. Contact an authorized METTLER TOLEDO representative for information about hazardous applications
Power	Operates at 100–240 VAC, 49–61 Hz, 400 mA (both enclosure types)
	Panel Mount version provides a terminal strip for AC power connections
	Harsh environment version includes a power cord configured for the country of use
	Note: When an IND780 is installed in an area classified as Division 2 or Zone 2/22, special AC wiring requirements must be met. See document 64063214, IND780 Division 2, Zone 2/22 Installation Guide
Display	320 x 240 pixel dot-matrix graphic backlit monochrome LCD or 320 x 240 pixel backlit graphic, active, TFT color LCD with the capability of displaying weight in 34-mm high characters; alternate multiple channel display
Weight Display	Displayed resolution of 1,000,000 counts for analog load cell scales
	Display resolution for high-precision IDNet bases is determined by the specific base used

IND780 Specifications	
Number of Scales	Interface for up to four scale channels plus a sum
Number of Flow Meters	Interface up to twelve flow meters
Keypad	30 keys; 1.22-mm thick polyester overlay (PET) with polycarbonate display lens
Communications	<p>Serial Interfaces Standard: Two serial ports COM1 (RS-232) and COM2 (RS-232/RS-422/RS-485), 300 to 115,200 baud; Ethernet 10/100 Base-T</p> <p>Protocol Serial Inputs: ASCII characters, ASCII commands for CTPZ (Clear, Tare, Print, Zero), SICS (most level 0 and level 1 commands)</p> <p>Serial Outputs: Continuous or Demand with up to ten configurable print templates or SICS host protocol, report printing, interfaces with external ARM100 Input/Output modules, and DeviceNet Bridge</p>
Approvals	<p>Weights and Measures USA: NTEP CoC # 06-017 Class II, 100,000d Class III, III L, 10,000d Canada: AM-5592 Class II 100,000d Class III 10,000d and Class III HD 20,000d Europe: TC6944 Class II, approved divisions determined by platform Class III, III L, 10,000e</p> <p>Product Safety UL, cUL, CE</p>

System Hardware

Main PCB

The IND780 terminal's main printed circuit board (PCB) includes provisions for the microprocessor, main memory, battery, application module key, Ethernet, USB and serial communications, and mounting of option boards.

The main board contains the COM1 and COM2 serial ports. COM1 provides RS-232 communication, while COM2 supports RS-232, RS-422, or RS-485 communication. These ports are bidirectional and can be configured for various functions such as demand output, SICS host communications, continuous output, ASCII command input (C, T, P, Z), ASCII character input, report printing, totals printing, or connection to a remote ARM100 module.

Scale Bases

The IND780 Q.iMPACT supports Analog, IDNet, SICS and POWERCELL PDX bases.

Analog Load Cell Scale Base

The IND780 Q.iMPACT supports this scale type through an analog load cell interface. The terminal can drive up to sixteen 350-ohm analog load cells, with up to eight 350-ohm load cells on one channel.

IDNet™ Scale Base

The IND780 Q.iMPACT supports both the newer T-brick style of high-precision base and the older "PIK-brick" transducers, through the IDNet scale interface. For T-brick bases, the interface provides the +12 volts and communication required to operate this newer style of base. The port also provides +30 volts, to support PIK-brick high-precision bases. The base's cable determines which voltage is used.

SICS Scale Base

The IND780 Q.iMPACT supports Mettler Toledo high precision scales and balances that utilize the SICS communications protocol. These scales and balances are branded as the Mettler Toledo Excellence balances, X-bases/platforms, WM/WMH and 4-series scales (BBx4xx, IND4xx). The SICS scales are connected to the IND780 via the serial interfaces. Four SICS scales can be supported per terminal, when optional Serial boards are installed. Depending on the type of SICS scale connected, different configuration settings will be available in the IND780 terminal setup screens.

POWERCELL® PDX® Scale Base

The IND780 Q.iMPACT supports scales that use the POWERCELL PDX communications network found in large hopper / tank applications as well as vehicle scales that use PDX® load cells. This interface also supports the use of the RAAD Box, which converts analog load cell signals into digital ones.

Flow Meter Interface Board

The Flow Meter Interface Board is a two-channel isolated Counter/Flow Meter board for use in the IND780 Q.iMPACT terminal. It is intended to provide a flow-meter totalizer target comparison to directly control on-board discrete outputs. The module is capable of counting input pulses at up to 50 kHz on each of two isolated input channels, as well as measuring the frequency of the input signal. A jumper-selectable switching threshold for each input channel is available, as well as a jumper-selectable 15 kHz analog filter. The input level range for the AC mode is 50mV to 50Vrms. The input level range for DC mode is 2.5 volts to 42 volts.

The outputs are 7407 open-collector drivers. Each module provides 150 mA of 5V power to drive opto-22 or similar devices. A total of two flow meters may be connected to a single flow meter card. Up to six flow meter cards can be installed

in a single Q.iMPACT terminal, so that each terminal can connect to as many as 12 flow meters.

PLC/DCS Interfaces

IND780 Q.iMPACT PLC/DCS interface options include :

- PROFIBUS® DP
- ControlNet™
- EtherNet/IP®
- Modbus TCP *
- DeviceNet™*
- Allen-Bradley RIO*

* Due to the limited amount of data that can be transmitted per message, or in a given amount of time, these three interfaces will not provide the same level of integration as PROFIBUS DP, ControlNet or EtherNet/IP. Please consult your METTLER TOLEDO Q.iMPACT representative for more information.

- The PLC/DCS option board mounts in a dedicated socket on the IND780 main board, and does not occupy one of the “option board” slots described in **Q.I System Capabilities** on page 1-4.

For detailed information on configuring these interfaces, please refer to the **IND780 Technical Manual** and the **IND780 PLC Interface Manual**, provided on the IND780 documentation CD.

PROFIBUS DP

The IND780 Q.iMPACT Terminal communicates to a PROFIBUS-DP master according to DIN 19 245. The PROFIBUS option consists of a module, together with firmware that resides in the IND780 Terminal to implement the data exchange.

ControlNet and EtherNet IP

The IND780 Q.iMPACT supports ControlNet communications or EtherNet / IP interface options and the appropriate driver software.

Modbus TCP

Modbus TCP is used to establish master-slave/client-server communication between intelligent devices. It is an open standard network protocol, widely used in the industrial manufacturing environment. The Modbus TCP protocol takes the Modbus instruction set and wraps TCP/IP around it. The Modbus TCP protocol is supported by the Ethernet / IP interface board, version 1.32 or higher.

DeviceNet™

DeviceNet is an RS-485 based network using CAN chip technology. This network was created for bit- and byte-level devices. The network can be configured to run up to 500kbits per second depending on cabling and distances. Messages are

limited to 8 unfragmented bytes. The network can include up to 64 nodes including the master, which is commonly called the scanner.

Allen-Bradley RIO

The A-B RIO option enables data exchange by bi-directional communications using the Discrete Data Transfer or Block Transfer mode. The IND780 Terminal initiates a communication exchange with the PLC approximately 20 times per second utilizing the Allen-Bradley Discrete Data Transfer protocol. This communication is a high-speed, real-time message interface between the IND780 Terminal and the PLC for process control. Division, integer, and floating point values are supported.

The IND780 A-B RIO interface also supports Block Transfer mode for transmission of larger amounts of data. Additional details about this interface can be found in the IND780 PLC Interface Manual on the IND780 documentation CD.

Options

The following additional options are available for the IND780. Only options compatible with the IND780 Q.iMPACT terminal are listed here.

- Predictive Adaptive Control (PAC) algorithms
- Discrete I/O
- Serial Communications
- Mounting hardware – brackets for wall and column mounting of the harsh enclosure

The scale measurement channel, flow meter measurement channel, serial and discrete I/O options are connected to the IND780 through six internal option slots. Various combinations of options may be ordered to match the application solution requirements.

Predictive Adaptive Control Algorithms

The powerful Predictive Adaptive Control (or PAC) Algorithms automatically compensate for natural process variations and adjust the material feed cutoff accordingly. Patented and exclusively available from METTLER TOLEDO, the PAC algorithms were developed to reduce material fill variation, increase throughput and lower capital equipment costs. The algorithms can be applied to scale equipment channel modules and flow meter equipment channel modules. The PAC Algorithms are enabled on the IND780 Q.iMPACT terminal when you select the appropriate software module along with the Q.i application module.

Discrete I/O

The discrete I/O interface options include both internal and remote I/O.

The internal version is available with dry-contact relay or solid state relay outputs. Both types will switch up to 30 volts DC or AC and up to 1 amp of current. The inputs are switch-selectable as either active (for simple pushbutton control) or

passive (for connection to PLCs or other devices that supply their own power for the I/O). Each internal board supports four inputs and four outputs.

The remote I/O is supported with the ARM100 remote module that provides dry-contact outputs. The inputs are passive on the ARM100. Each ARM100 supports four inputs and six outputs. An external 24-volt DC supply is required to operate the ARM100.

A total of two internal Discrete I/O boards (each providing 4 inputs and 4 outputs) are supported, with an additional 32 inputs and 48 outputs in up to eight remote I/O modules.

Serial Communications

Additional communications cards provide RS-232, RS-422 or RS-485 communication at rates from 300 to 115.2k baud. A maximum of two serial communications cards may be installed in the IND780.

Mounting Hardware

Please refer to Chapter 4, **Parts and Accessories**, of the **IND780 Technical Manual**.

TaskExpert™

TaskExpert is included with the Q.iMPACT application. TaskExpert is the custom programming language for the IND780 and IND780 Q.iMPACT terminals. Enabled by selecting the appropriate software module, TaskExpert allows for custom application specific programming to reside in the IND780 Q.iMPACT terminal to meet your needs.

Q.i Material Transfer Control Strategy

Before setting up and using the IND780 Q.iMPACT terminal, it is important to understand:

- How the Q.i material transfer control strategy works
- The role Q.i plays in your process control operation
- When to apply the Q.i material transfer control strategy

Overview

Predictive Control Algorithms

At the heart of the Q.iMPACT application, patented predictive adaptive control algorithms (PACs) build a real-time mathematical model of the material transfer process for each material. These algorithms learn and compensate for process variations in each active material transfer – a function known as auto-tuning. The point in time at which the terminal will stop adding material is adjusted continuously during the transfer, as the terminal learns to predict how the delivery

system will react. This allows the system to adapt to changes in the flow rate of the material while the transfer is in progress.

This produces a very high degree of accuracy in controlling material transfer, using only a single fast feed. Each material transfer is treated as a separate transaction, initiated when the Host system (normally a PLC or DCS) sends a target value to the Q.iMPACT terminal for a particular scale or flow meter feed. The Q.iMPACT terminal then controls the addition of the material and, when the transfer is complete, sends the result to the Host system.

The result is a material transfer system that delivers optimal performance, by producing significant reductions in costly raw material over-feed, unacceptable under-feed and material feed time.

Material Feeds

A material feed is the most basic and most frequently used operation in a batch control system or filling operation. To complete a batch recipe, two or more material feed phases must occur. For a filling or packaging cycle, typically one feed phase occurs repeatedly.

The most challenging and critical part of any material feed occurs at the end of a phase, when the feed is cut off in accordance with a recipe, formulation or filling operation. Virtually all material feed inconsistencies result from inaccurate cut-off, making this a significant area for process improvement.

Normally, a number of material transfers must take place in order to create a batch. The exact order, sequence and quantity of each material transfer is determined by the "Recipe".

Components of an IND780 Q.iMPACT System, and Terminal Clustering

Each IND780 Q.iMPACT terminal can support up to four scales or twelve flow meters, or a combination of these. Each scale or flow meter is referred to as an Equipment Channel Module. If more scales or flow meters are required, more terminals can be added. To create a single manageable system, as many as twenty IND780 Q.iMPACT terminals may be connected via an Ethernet network, to create a "cluster".

All members of a cluster share a single common database, maintained in an IND780 Q.iMPACT terminal assigned to be the master. All other terminals in the cluster are configured as remote. The master terminal is responsible for distributing the database variables to all remote terminals in the cluster.

For each instrument (scale, load cell system or flow meter,) the sequence of events occurs in parallel. For example, if a Q.iMPACT terminal has two scale inputs and three flow meter inputs, then it can control five material transfers simultaneously.

Not all of the IND780 Q.iMPACT terminals in a cluster require a direct communications link (ControlNet, for example) to a Host system. Depending on system configuration, in a cluster of three Q.iMPACT terminals only one terminal

may require the ControlNet interface board. The Q.iIMPACT terminal with the interface board is referred to as containing a “bridge”.

Any IND780 Q.i terminal in a cluster, whether master or remote, can serve as a bridge terminal to the host PLC or DCS system. Please use best practices when configuring your cluster to distribute the processing load evenly between the master database and your equipment channel modules, I/O and communications.

Material Paths

Each control valve, feed conveyor, etc. is assigned a Material Path (MP) number. This number identifies a unique path that a material will take from a source container to its destination container.

Example A

A scale with two valves controls the addition of materials A and B. The scale also has a discharge valve. This system has a single equipment channel (the scale) and three material paths – two for addition to the scale, one for discharge from the scale. Each is a unique path that the material must follow, and each has its own characteristics, such as flow rate. These three material paths can be referred to as MP1, MP2 and MP3.

Equipment Channel Module	Material Path	Function
1 (scale)	MP1	Addition of material A
1 (scale)	MP2	Addition of material B
1 (scale)	MP3	Discharge from scale

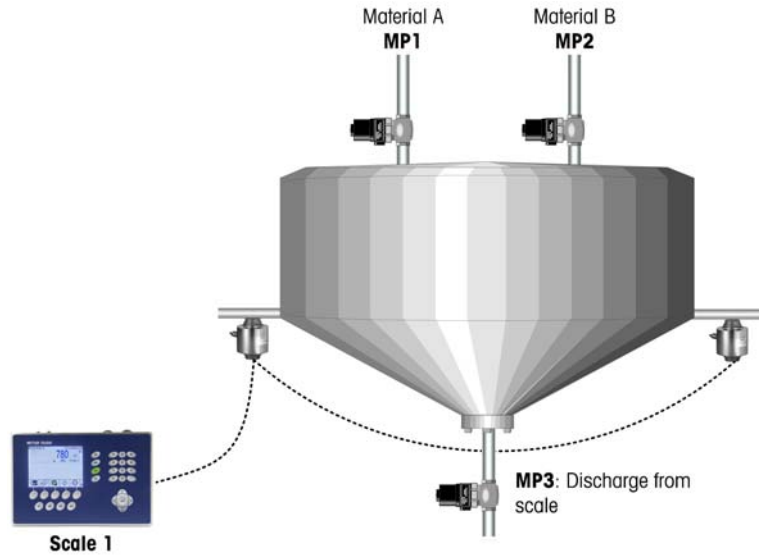

Figure 1-9: Example A

Example B

Suppose that demand for the product being manufactured in this operation has increased, and now exceeds the capacity of the system in Example A. To increase production, a second scale is added. It uses the same raw materials from the same bulk storage container, and discharges the resulting mixture into the same bulk storage tank. However, it has its own control valves, allowing throughput to be doubled. This means that, even though it uses the same sources of raw materials, three new unique material paths associated with the second scale have been added to the system:

Equipment Channel Module	Material Path	Function
1 (scale 1)	MP1	Addition of material A
1 (scale 1)	MP2	Addition of material B
1 (scale 1)	MP3	Discharge from scale 1
2 (scale 2)	MP4	Addition of material A
2 (scale 2)	MP5	Addition of material B
2 (scale 2)	MP6	Discharge from scale 2

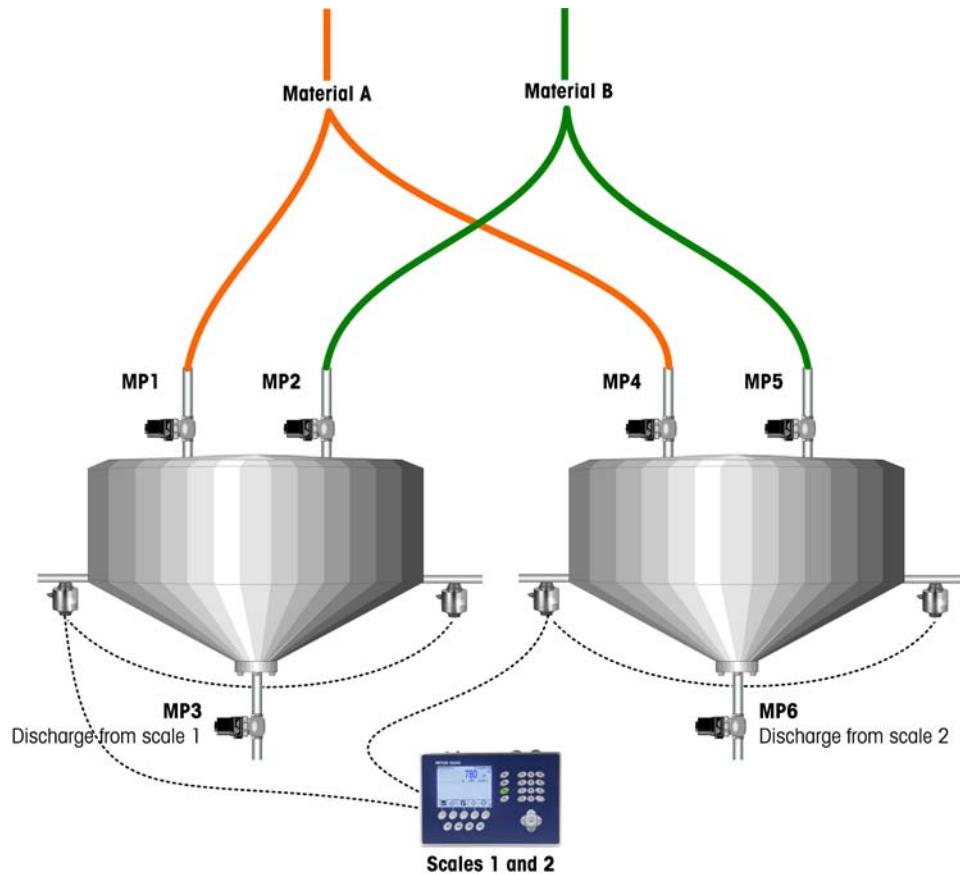

Figure 1-10: Example B

Example C

Colorant is now added to the system described in Example B above, using a flow meter to control the addition for each scale. This system includes two more channels (flow meters 1 and 2) and two more material paths (one for each flow meter). It is important not to increase the batch cycle time, so the Q.i strategy's advanced overlapping feed capabilities can be used to add the colorant at the same time as material A. Batch cycle time is not increased, and the system now looks like this:

Equipment Channel Module	Material Path	Function
1 (scale 1)	MP1	Addition of material A
1 (scale 1)	MP2	Addition of material B
1 (scale 1)	MP3	Discharge from scale 1
2 (scale 2)	MP4	Addition of material A
2 (scale 2)	MP5	Addition of material B
2 (scale 2)	MP6	Discharge from scale 2
3 (Flow meter 1)	MP7	Addition of colorant
4 (Flow meter 2)	MP8	Addition of colorant

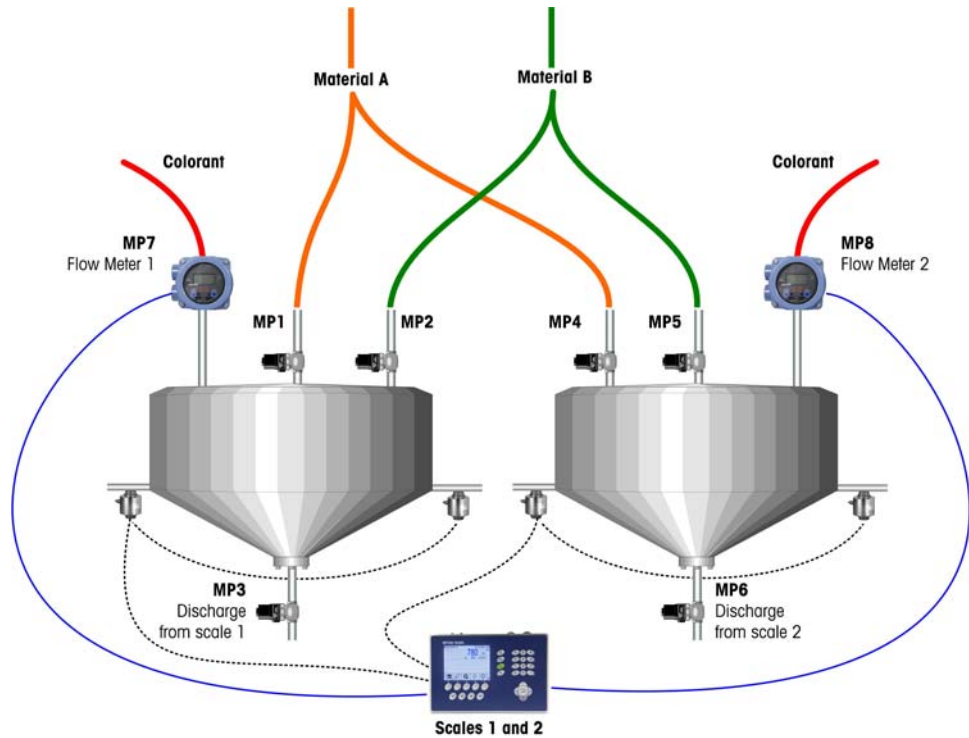

Figure 1-11: Example C

Examples of IND780 Q.i Systems

One Q.iIMPACT terminal can be used for systems requiring up to four scale or load cell measurement channels, twelve flow meter measurement channels, or some combination of these. Larger systems, with up to one hundred ninety eight measurement channels, can take advantage of the Q.i clustering capability. Figure 1-12, Figure 1-13 and Figure 1-14 give three examples of Q.iIMPACT systems.

IND780-based Q.iIMPACT Systems

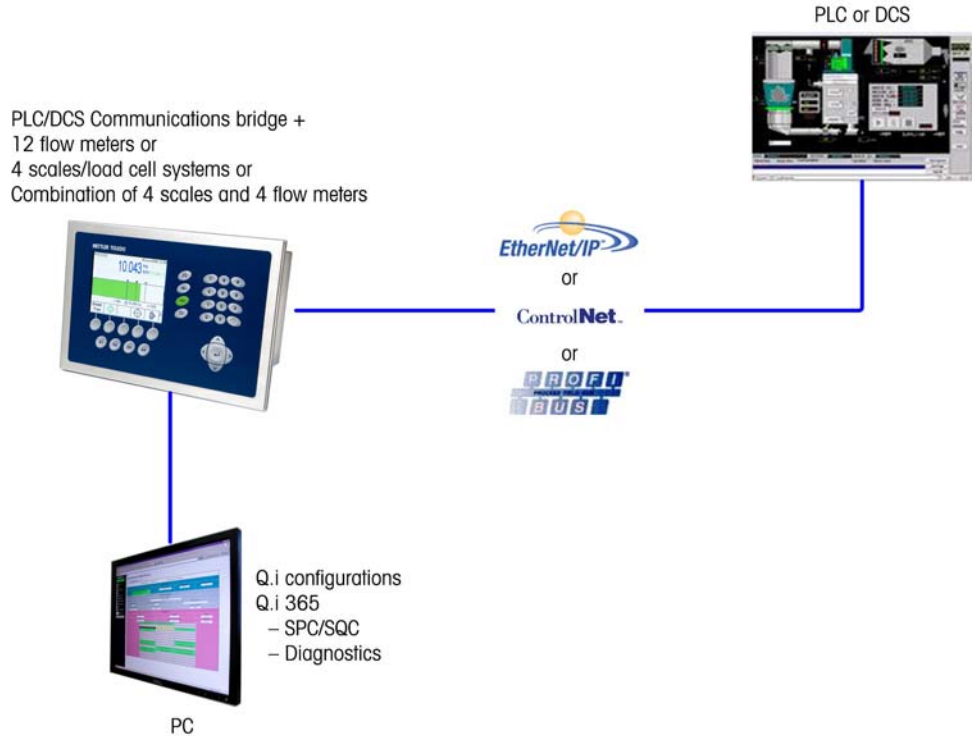

Figure 1-12: Single Terminal System

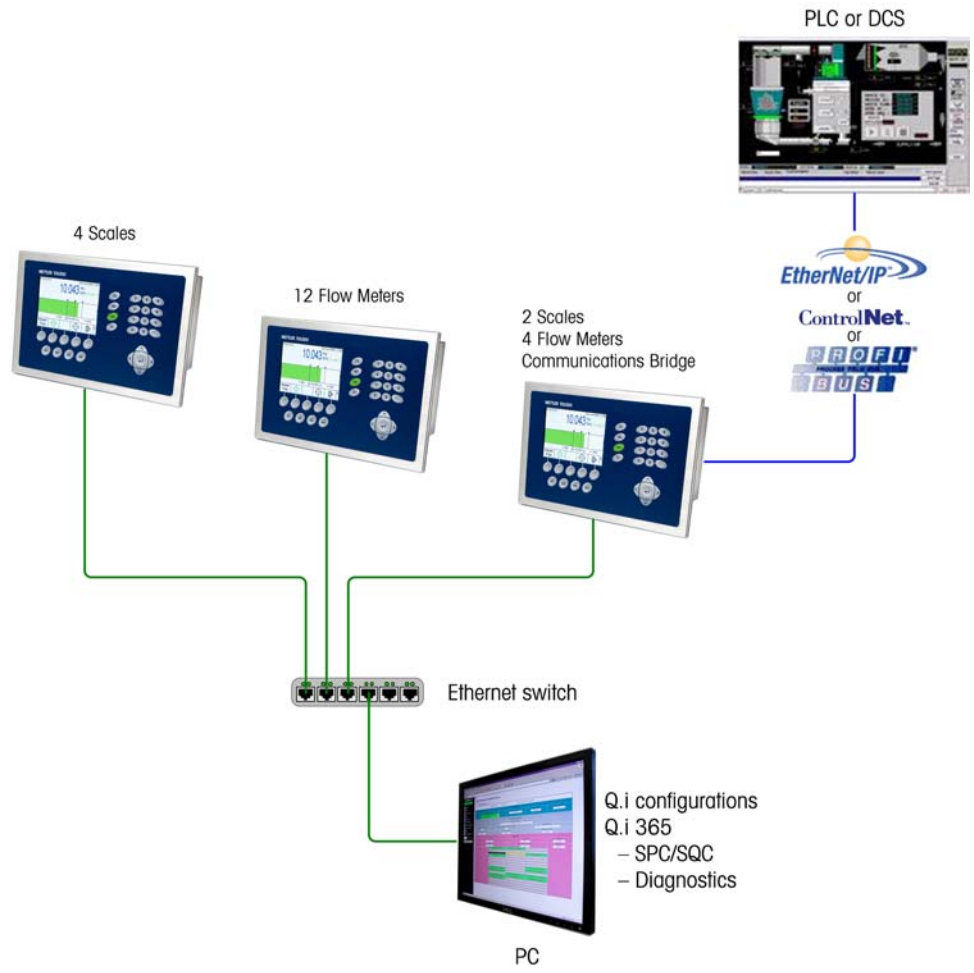

Figure 1-13: Multi-Terminal System

Using IND780- and JagXtreme-based Q.iIMPACT Terminals in the Same System

It is not necessary to replace existing JagXtreme Q.i matrollers in order to use the greater functionality of the IND780 Q.iIMPACT.

However, the JagXtreme-based Q.i and IND780-based Q.i can share the same PLC and the same process, as shown in Figure 1-14.

- The JagXtreme-based Q.i and the IND780-based Q.i cluster in similar ways, but they cannot share a cluster. This is because the newer IND780 platform communicates over the Ethernet using multi-cast, which is more open and has better reliability than the discrete messaging protocol used by the JagXtreme.

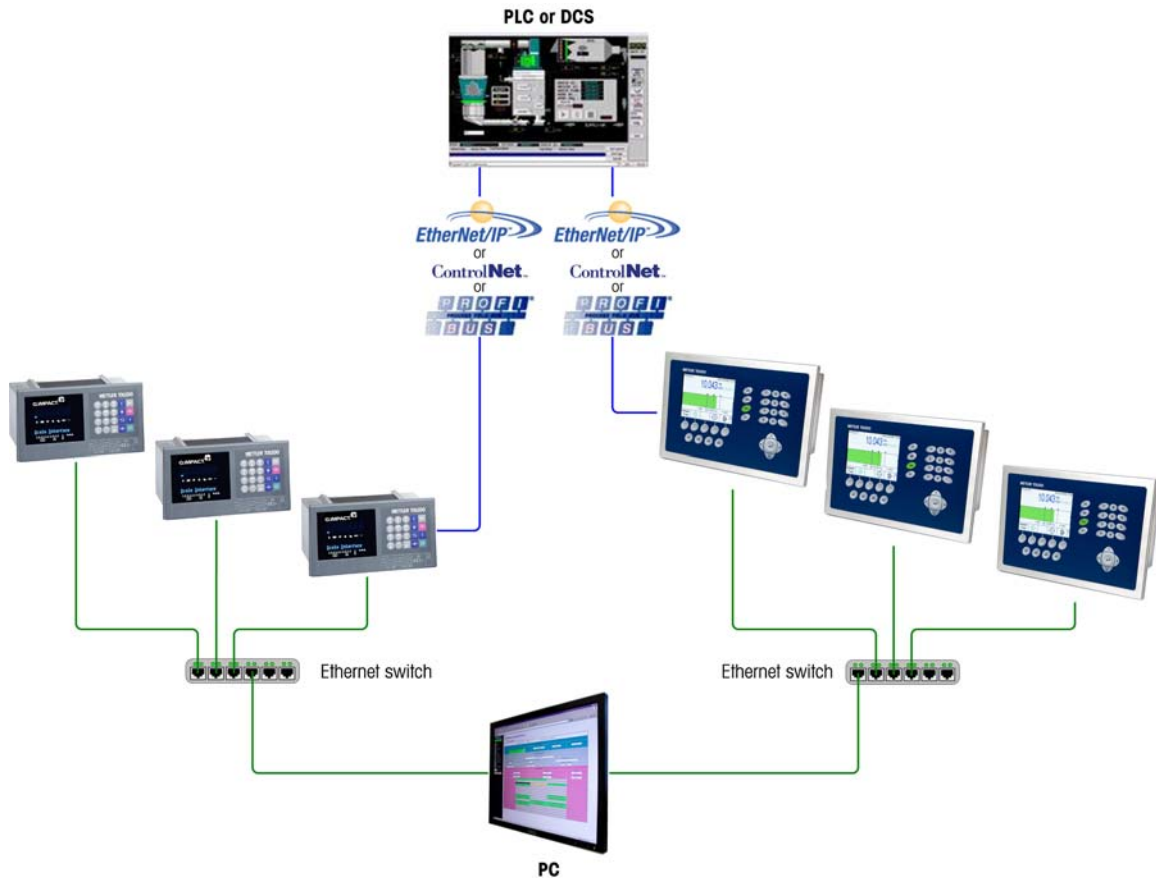

Figure 1-14: Multi-Terminal System Including JAGXTREME and IND780 Q.iIMPACT Terminals

Components of an IND780 Q.iIMPACT System

Figure 1-15 illustrates the relationship between components of an IND780 Q.iIMPACT system that includes one equipment channel (scale) input and one final control element (FCE) output.

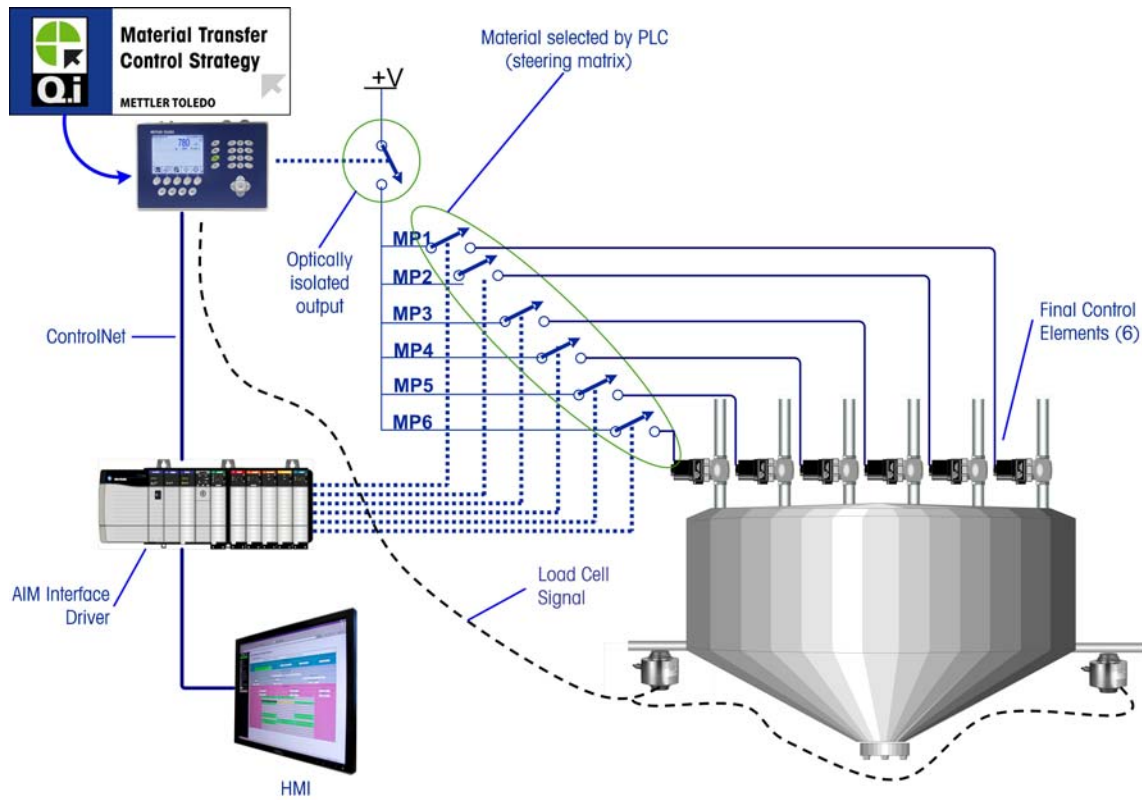

Figure 1-15: Wiring Example – Q.i with 6 Material Paths and One Measurement Channel

Communicating with the IND780 Q.iIMPACT Terminal

There are three ways to communicate with the IND780 Q.iIMPACT:

- The IND780 terminal control panel
- The PC-based Q.i Configuration Tool
- The IND780's web-based server

The elements of each communication type are detailed in Chapter 3 of this manual, **Configuration**.

Terminal Control Panel

Q.iMPACT parameters can be viewed, set up and modified from the IND780 Q.iMPACT terminal's front panel. The setup menu tree is shown in Figure 1-16, with the **Q.i Configuration** branch expanded.

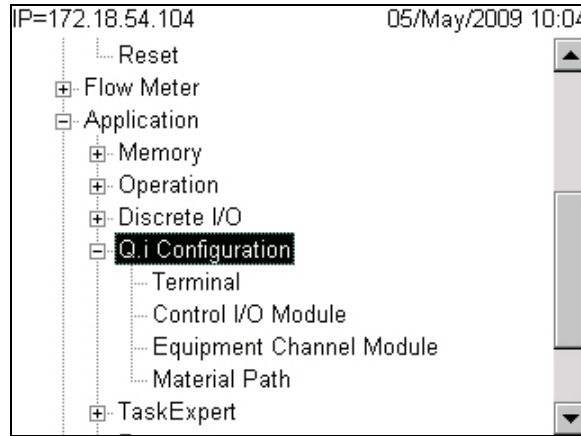

Figure 1-16: Setup Menu Tree, Q.i Configuration Branch Expanded

Q.i Configuration Tool

The Q.i Configuration tool is a PC-based HMI utility developed exclusively for the IND780 Q.iMPACT terminal. To use this utility:

- The tool must be loaded on your PC
- The PC must be equipped with a standard Ethernet connection
- The IP address of the IND780 Q.iMPACT terminal must be known

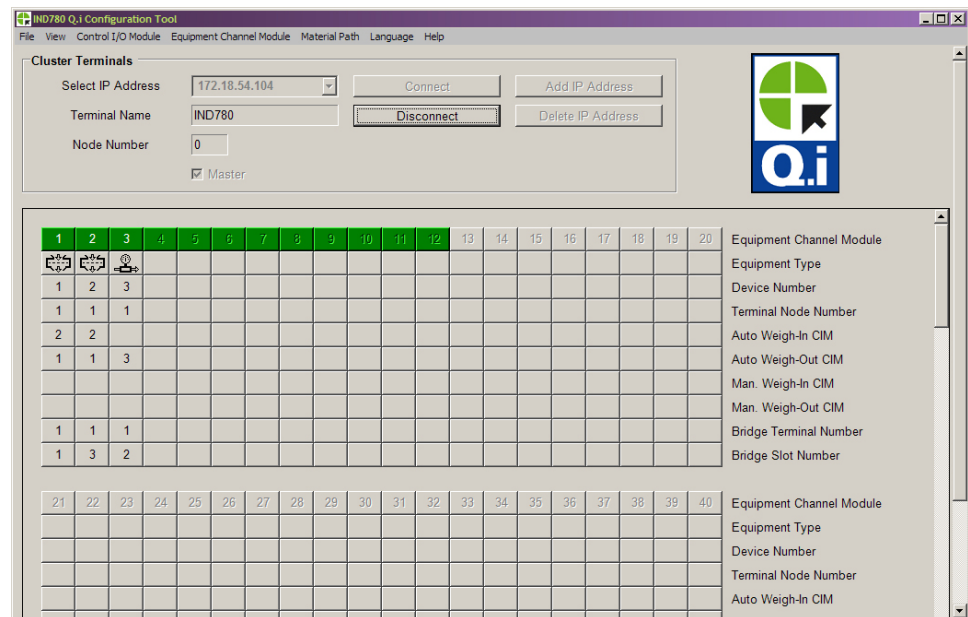

Figure 1-17: Q.i Configuration Tool Main Page

Web Pages

A standard Ethernet connection to the IND780 Q.iMPACT terminal allows access to its external diagnostics feature, a series of web pages that permit the current configuration to be viewed and, in some cases, modified. To access the web pages:

- The PC must be equipped with a standard Ethernet connection
- The IP address of the IND780 Q.iMPACT terminal must be known

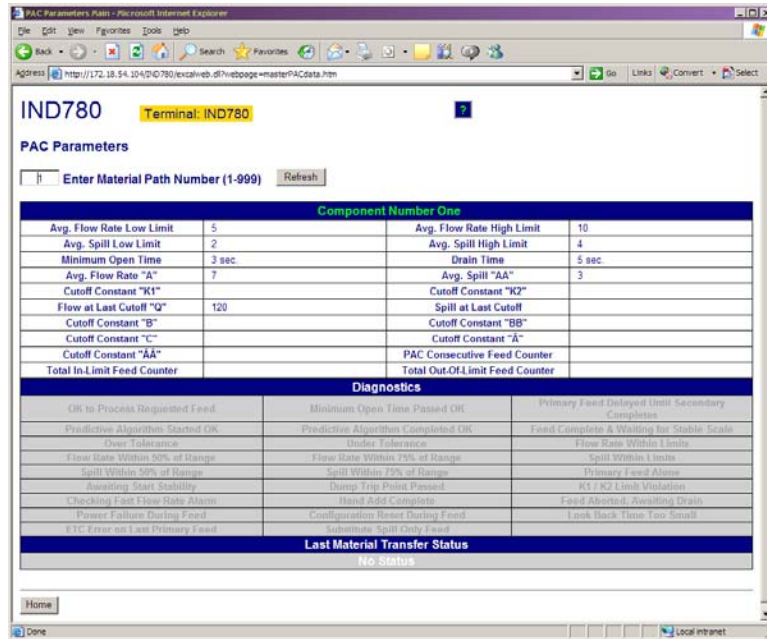

Figure 1-18: IND780 External Diagnostics, PAC Parameters Page

IND780 Q.iMPACT/Host Controller Communications

Fieldbus Types

Three forms of Fieldbus communications provide **full** connectivity with the Q.iMPACT terminal:

- ControlNet
- EtherNet/IP
- Profibus DP

In addition, three types of Fieldbus provide **limited** connectivity with the Q.iMPACT terminal:

- Modbus TCP
- Allen-Bradley RIO
- DeviceNet

Communication Modes

Two types of communication modes are available for the Q.iMPACT terminal. This selection is made in the **Q.i Configuration** section of setup.

Classic Communication Mode

This was the only communication mode available with the first generation Q.iMPACT application on the JAGXTREME[®]-based terminal. This form of communication uses Explicit Shared Data messages over ControlNet or Ethernet IP communications protocol.

New users can choose to use this mode of communication. Q.i customers upgrading from the JAGXTREME-based Q.i platform may select this mode to avoid or minimize modifications to communication between the Q.i terminal and the Host Controller.

Enhanced Communication Mode

The Enhanced Communication Mode is new for the IND780 Q.iMPACT terminal. This mode uses only cyclic messaging to communicate between the Host Controller and the Q.iMPACT terminal.

For further details on communications modes, refer to Appendix D of this manual, **Communications**.

Chapter 2.0

Installation

This chapter covers



- Opening the Enclosures
- Mounting the Terminal
- Harsh Enclosure Cable Openings
- Wiring Connections
- PLC Interface Modules
- PCB Switch Settings
- PCB Jumper Positions
- Sealing the Enclosure



This chapter provides installation instructions for the IND780 Q.iMPACT terminal, and connecting its external wiring.

- Because IND780 Q.iMPACT is part of a larger system, its installation is likely to be affected by other components of the system. Please refer to any additional information supplied with optional interface boards provided by METTLER TOLEDO, or any documentation supplied by vendors of other components used in the system (PLC systems, DCS platforms, flow meters, etc.). Operation and configuration information is provided elsewhere in this manual.



Precautions

- READ this manual BEFORE operating or servicing this equipment
- FOLLOW these instructions carefully.
- SAVE this manual for future reference.

	 WARNING!
	ONLY PERMIT QUALIFIED PERSONNEL TO SERVICE THE TERMINAL. EXERCISE CARE WHEN MAKING CHECKS, TESTS AND ADJUSTMENTS THAT MUST BE MADE WITH POWER ON. FAILING TO OBSERVE THESE PRECAUTIONS CAN RESULT IN BODILY HARM AND/OR PROPERTY DAMAGE.

	 WARNING!
	NOT ALL VERSIONS OF THE IND780 ARE DESIGNED FOR USE IN HAZARDOUS (EXPLOSIVE) AREAS. REFER TO THE DATA PLATE OF THE IND780 TO DETERMINE IF A SPECIFIC TERMINAL IS APPROVED FOR USE IN AN AREA CLASSIFIED AS HAZARDOUS BECAUSE OF COMBUSTIBLE OR EXPLOSIVE ATMOSPHERES.

	 WARNING!
	<p>WHEN THIS EQUIPMENT IS INCLUDED AS A COMPONENT PART OF A SYSTEM, THE RESULTING DESIGN MUST BE REVIEWED BY QUALIFIED PERSONNEL WHO ARE FAMILIAR WITH THE CONSTRUCTION AND OPERATION OF ALL COMPONENTS IN THE SYSTEM AND THE POTENTIAL HAZARDS INVOLVED. FAILURE TO OBSERVE THIS PRECAUTION COULD RESULT IN BODILY HARM AND/OR PROPERTY DAMAGE.</p>

	 CAUTION!
	<p>RISK OF EXPLOSION IF BATTERY IS REPLACED WITH WRONG TYPE OR CONNECTED IMPROPERLY. DISPOSE OF BATTERY ACCORDING TO LOCAL LAWS AND REGULATIONS.</p>

 CAUTION
<p>OBSERVE PRECAUTIONS FOR HANDLING ELECTROSTATIC SENSITIVE DEVICES.</p>

 CAUTION
<p>BEFORE CONNECTING/DISCONNECTING ANY INTERNAL ELECTRONIC COMPONENTS OR INTERCONNECTING WIRING BETWEEN ELECTRONIC EQUIPMENT ALWAYS REMOVE POWER AND WAIT AT LEAST THIRTY (30) SECONDS BEFORE ANY CONNECTIONS OR DISCONNECTIONS ARE MADE. FAILURE TO OBSERVE THESE PRECAUTIONS COULD RESULT IN DAMAGE TO OR DESTRUCTION OF THE EQUIPMENT AND/OR BODILY HARM.</p>

Unpacking and Inspection

To verify the configuration of the IND780 Q.iMPACT terminal, refer to its data label and to the Model Identification chart in Chapter 1 of this manual, **Introduction**.

The IND780 Q.iMPACT should include the following items:

- IND780 Q.iMPACT terminal
- Option board/s with ferrite kits, depending on system specification
- Q.iMPACT Documentation CD-ROM (64068642)
- IND780 Documentation CD-ROM (64057241)
- Hardware Kit of Parts (64057809)
- Printed **IND780 Q.iMPACT Installation Manual**
- Printed **IND780 Installation Manual** (64057253)

Opening the Enclosure

Procedures for opening the IND780 terminal panel mount and harsh enclosures differ and are described in the following sections.

Only qualified personnel should perform installation, programming and service. Please contact a local METTLER TOLEDO representative for assistance.

In general, once the IND780 is installed, programmed and calibrated for a given application, only routine calibration service is required.

Panel Mount Enclosure

The panel mount enclosure is designed to allow the system integrator or installer to have easy external access to connectors, minimizing the need to access the interior of the unit. On some occasions, the rear cover must be removed to add option cards or to set internal switches. The Panel Mount version of the IND780 is opened by removing the four Phillips head screws on the back panel, circled in Figure 2-1. The rear panel can then be removed.

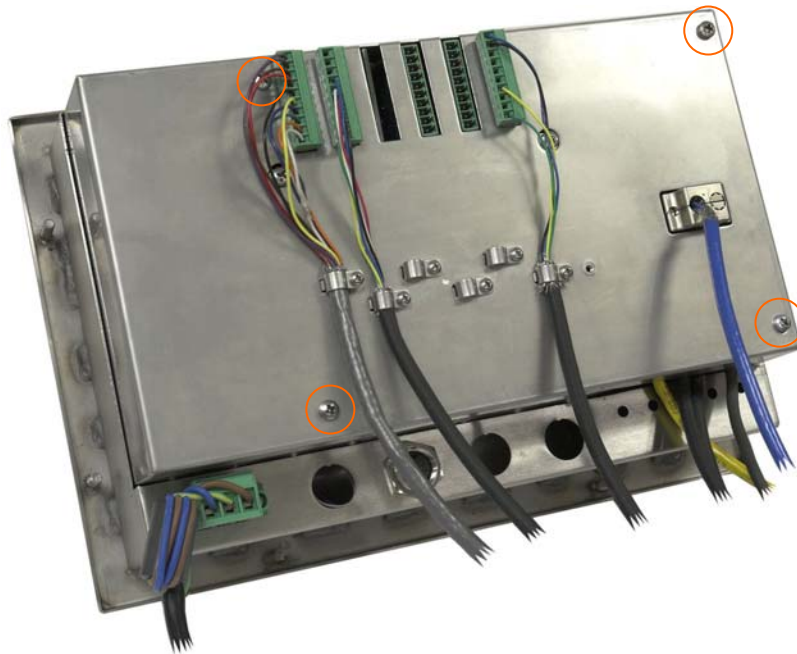

Figure 2-1: Opening the Panel Mount Enclosure

Harsh Enclosure

The front panel of the harsh enclosure IND780 terminal is locked in place by four spring clips attached to the enclosure body. To gain access to the terminal's PCB for internal wiring and setting switches, separate the front panel from the enclosure as follows:

1. Place the terminal on a stable, flat surface, with its front panel facing up.



Figure 2-2: Opening the Harsh Enclosure

2. Insert the tip of a flat blade screwdriver into one of the two slots located on the edge of the front panel assembly (see Figure 2-2). Squeeze the top of the front panel firmly down against the enclosure, in order to relieve the pressure on the retaining clip, and push the screwdriver in toward the enclosure until a “pop” sound is heard.
3. Repeat Step 2 for the other slot, freeing the bottom of the cover from the spring retaining clips.
4. Once the panel is released, lift the bottom of the panel firmly up and out until it clears the edge of the enclosure.
5. Press down on the top of the front panel and push the panel upward, relative to the enclosure, until the spring retaining clips unsnap. The cover will then be free to swing down, hinged by two wire cables at its bottom edge.

Mounting the Terminal

The Panel Mount enclosure is designed to mount into a cutout of a flat surface such as an instrument panel or industrial enclosure or door. The harsh enclosure is designed to be placed on a desktop or can be mounted to a vertical surface with the optional mounting brackets. Mount the terminal where viewing is optimal and the terminal keypad is easily accessible. Observe location and environment considerations as described in Chapter 1.0, **Introduction**.

Panel Mount Enclosure

The Panel Mount enclosure comes with a gasket and a backing plate, used to mount the unit to a panel. The enclosure will mount and seal properly on panel thicknesses from 16 GA to 11 GA (1.52 mm to 3.04 mm).

Install the Panel Mount enclosure by following these steps:

Cut an opening and holes in the panel or industrial enclosure as indicated in the panel cutout dimensions shown in Figure 2-3 in inches and [mm].

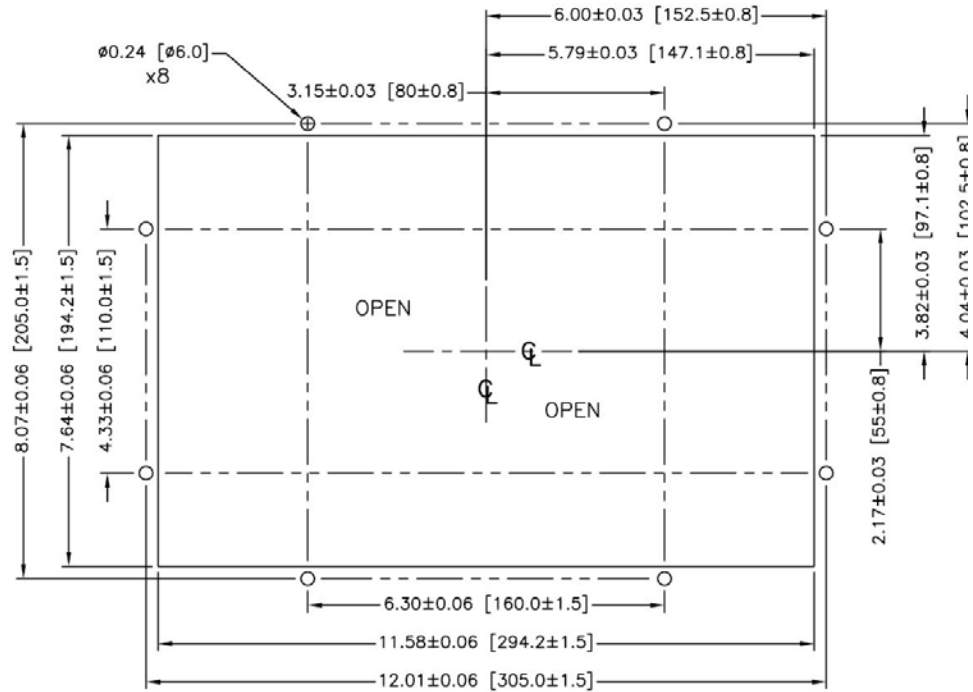

Figure 2-3: Panel Cutout Dimensions

Loosen and remove the eight, 8 mm shoulder nuts holding the backing plate to the enclosure. The gasket should remain in position on the terminal. Figure 2-4 shows two images of the enclosure, one with the backing plate removed to show the gasket, the other with the backing plate installed.

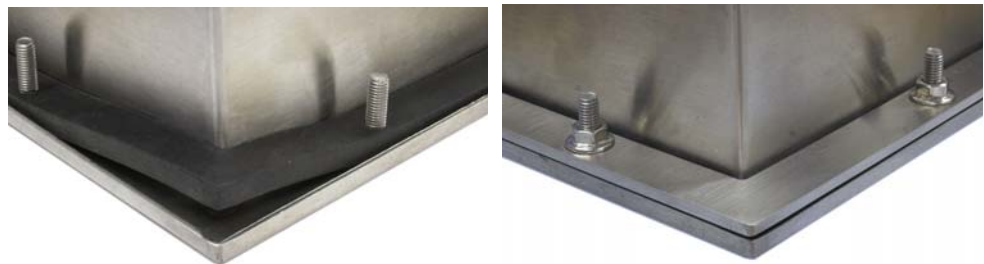

Figure 2-4: Gasket on Enclosure (left) and Backing Plate Installed (right)

Place the terminal through the cutout from the front and secure by fitting the backing plate over the back of the terminal, then installing and tightening the eight nuts until secure. Figure 2-5 shows a side view of a panel installation.

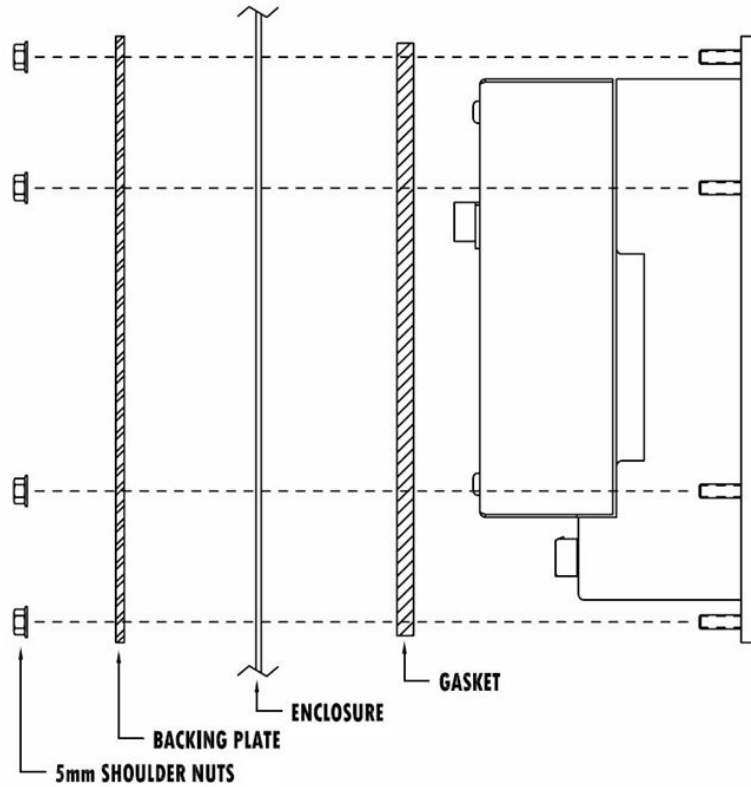

Figure 2-5: Panel Mounting, Side View

Harsh Enclosure

The harsh enclosure is made of stainless steel and designed to rest on a flat surface such as a table or desk top, or to be mounted to a vertical surface with optional mounting brackets. In desktop configuration, the front panel angle is approximately 70 degrees from vertical. In wall mount configuration, the front panel is approximately 40 degrees from vertical, and reversible (angled up or down).

Desktop Mounting

If the IND780 terminal is to be placed on a flat surface, the four rubber feet included with the terminal should be adhered to the bottom of the enclosure to prevent sliding. Peel each foot from the protective paper and press it onto one corner of the bottom of the enclosure, as shown in Figure 2-6.



Figure 2-6: Rubber Feet for Desktop Mounting

Preparation for Wall Mounting

An optional wall bracket kit is available for wall mounting the IND780 harsh enclosure to a vertical surface. To prepare the enclosure for wall mounting, follow these steps:

1. Establish orientation of enclosure (above or below eye level)
2. Install enclosure on brackets
3. Mark attachment points
4. Install mounting hardware
5. Mount terminal hardware

Setting Front Panel Orientation

Establish whether the terminal will be mounted above or below eye level. If it will be mounted at or below eye level, the orientation of the front panel must be reversed. Follow these steps:

1. Open the enclosure as described in the Opening the Enclosures section.
2. Loosen and remove the two nuts securing the two metal cables (Figure 2-7) that hinge the front cover to the rear housing.

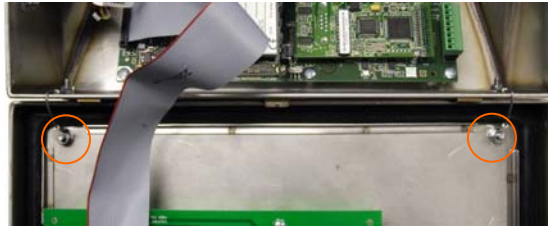

Figure 2-7: Ground Strap Attachment Locations

3. Carefully rotate the front cover 180 degrees and reattach the two grounding straps to the two studs near the grip bushings using the two nuts removed in the previous step. Figure 2-8 shows one of the studs. Tighten the two nuts.



Figure 2-8: Stud for Attaching Reversed Front Panel

Attaching the Enclosure to the Brackets

Once the brackets are securely fastened to the wall surface, the enclosure can be mounted to them using the four supplied M5 screws. One bracket is shown in Figure 2-9, with the slotted holes indicated. The screws are tightened by fitting the screwdriver through the slotted holes.

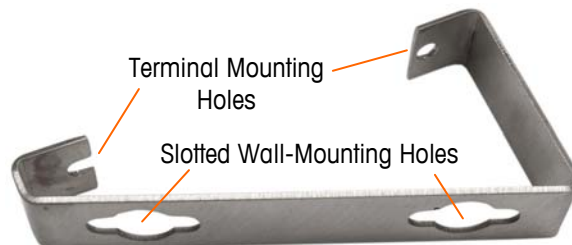

Figure 2-9: Wall-Mounting Bracket

Figure 2-10 shows the brackets attached to an enclosure. Note the orientation of the enclosure relative to the brackets.



Figure 2-10: Attaching the Wall-Mounting Brackets

Marking Mounting Hole Position

Mark the position of the mounting holes on the vertical surface per the dimensions shown in Figure 2-11 in inches and [mm], or by holding the terminal up to the surface and marking through the bracket holes.

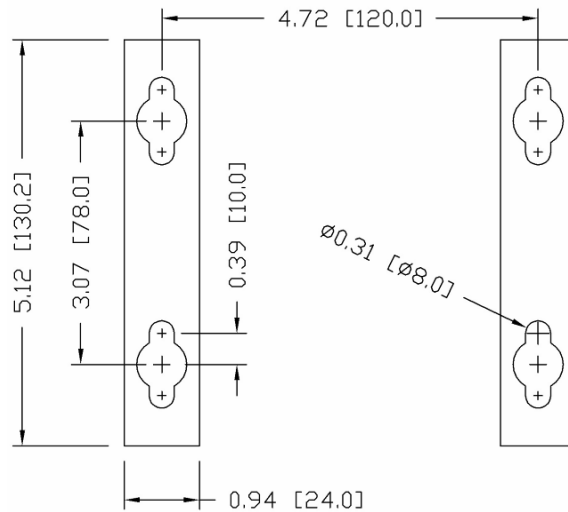

Figure 2-11: Mounting Hole Pattern

Once the mounting hole positions are established, perform one of the following procedures, depending on the type of wall surface.

- The hardware to mount the terminal to the vertical surface is not included with the terminal – it must be supplied locally. Ensure that the mounting hardware is capable of supporting the weight of the terminal, which is approximately 11 lb (5 kg).

CAUTION: When carrying out the following procedures, wear proper bodily protection, such as approved safety goggles, ear protectors and gloves.

Wall Mounting, Wallboard or Drywall

When mounting the IND780 on wallboard, drywall or a similar surface, the anchor should be sized according to the recommended bolt size of 1/4" (6 mm). The recommended mounting hardware is:

- Four Toggle Bolts, 1/4" (6 mm), minimum length 2-1/2" to 3" depending on wall thickness, with a pullout force of 900 lb (450 kg)
- Four flat washers, minimum 1/2" (12 mm) outside diameter

Figure 2-12 shows an example of mounting hardware.



Figure 2-12: Sample Mounting Hardware, Wallboard or Drywall

1. Drill a hole through each of the measurements/locations marked while preparing for wall mounting. Use a bit with the same size bit as anchor diameter (typically 5/8" (16 mm)). The depth of the hole should penetrate the wallboard.
2. Clean the holes with a cloth moistened with water.
3. Unthread each toggle bolt and add a 1/4" (6 mm) inside diameter, flat washer with an outside diameter of 1/2" (12 mm).
4. Push the washers to the inside of the heads of all four bolts.
5. Replace each toggle nut and thread onto each bolt approximately 1" (25 mm). Insure that the ends of the nut fold toward you when you squeeze them.
6. Press the toggle nuts through each opening you created in the wall. You should hear a "click" sound when each snaps open on the other side.
7. Tighten the bolts down until you feel the toggle nut contact the inside of the wall. Tighten each with a wrench (use a screwdriver for flat/round heads), approximately two or three full turns or until the toggle nuts are against the base material on the inside of the wall.
8. Back each bolt out enough to leave space for its head and the flat washer to engage the top center of one of the slotted holes in the mounting brackets (see Figure 2-9 and Figure 2-11).
9. Turn the screws, by hand, until they are snug against the mounting plate. Figure 2-13 shows the nut, washer and bolt installed.

Wall Mounting, Concrete and Cement Blocks

When mounting the IND780 to a cement block, poured concrete or similar wall, the recommended mounting bolt is:

- UL-listed concrete sleeve anchor, size 1/4" (6 mm), minimum embed 1/2" (12.7 mm), minimum pullout force of 500 lb (266 kg).

Figure 2-13 shows an example of mounting hardware.



Figure 2-13: Sample Mounting Hardware, Concrete or Cement

1. Drill a hole through each of the measurements/locations you marked in the Preparation for Wall Mounting section. Use a carbide bit conforming to ANSI B94, 12-77 with the same size bit as anchor diameter (typically 5/16" (8 mm)). The depth of the hole should be deeper than 1/2" (12 mm).
2. Clean the holes with a wire brush.
3. Make sure the head of the bolt is flush with the top threaded part of the anchor then insert the anchor assembly through the mounting holes and into the base material.
4. Push anchor assembly until washer is snug against the wall.
5. Tighten each bolt with a wrench (use a screwdriver for flat/round heads), approximately three or four full turns or until anchor is tightly secured to the base material.
6. Back the bolts out sufficiently to allow them and their washers to engage the top center of one of the slotted holes in the mounting brackets (see Figure 2-9 and Figure 2-11).

Wall Mounting, Wood Surface

When mounting the IND780 to a wooden wall or similar surface, use four #12 screws of at least 1 1/4" (30 mm) length, each with a flat washer of minimum 1/2" (12 mm) diameter.

Install the screw and washer, leaving sufficient gap to accommodate the slotted hole in the bracket – see Figure 2-9 and Figure 2-11.

Periodically inspect the terminal to insure that it is securely anchored to the wall. If not, remove the terminal and retighten the mounting anchor bolts.

Positioning Terminal on Fasteners

Place the holes in the terminal brackets over the fasteners, and slide the terminal down firmly so that each fastener and washer engages the slots in the bracket (see Figure 2-9).

For wallboard or drywall mounting, after engaging the brackets pull them away from the wall until the toggle nuts are felt to contact the inside of the wall. If necessary, unmount the terminal and tighten the bolts slightly. Figure 2-14 shows the relationship between bracket, hardware and wall.

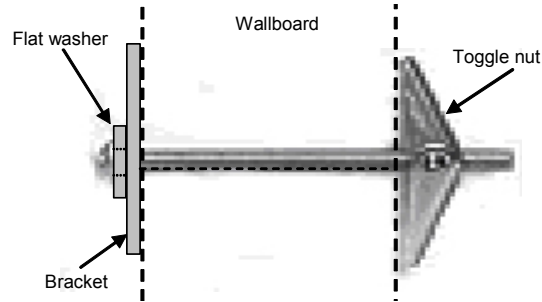

Figure 2-14: Wallboard or Drywall Installation

Periodically inspect the terminal to insure that it is securely anchored to the wall. If not, remove the terminal and retighten the mounting anchor bolts.

Ferrites and Option Board Cabling

Ferrites

In order to meet certain electrical noise emission limits and to protect the IND780 from external influences, it is necessary to install a ferrite core on each cable connected to the terminal. Two types of ferrites are supplied with the basic terminal, and additional ferrites may be supplied with each of the options.

- The large clamp ferrites can be attached to larger cables such as Ethernet, USB and some PLC cables.
- The large core ferrite is used with the panel mount power cable, serial interface and analog load cell cable.

To install the large core ferrite on the panel mount power cord, remove the insulation and shielding from the end of the cable. Before attaching the power connector, route the blue and brown wires through the center of the core and take two wraps around the outside of the core, each time routing the cables through again. Note that the striped green and yellow ground wire does not pass through the core. Similarly, on the analog load cell cable, wrap the individual wires around the ferrite core twice to reduce the effects of electrical noise and interference.

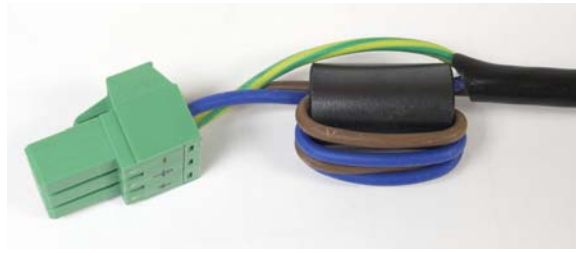

Figure 2-15: Ferrite Core on Panel Mount Power Cord

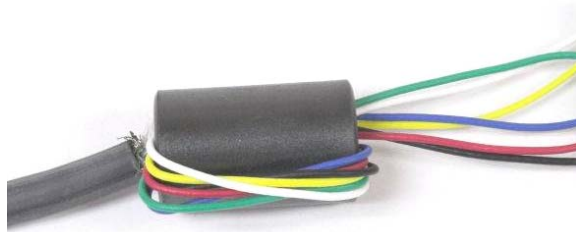

Figure 2-16: Ferrite Core on Analog Load Cell Cable

When using a clamp type ferrite, a loop can be made in the cable and the ferrite snapped over the spot where the cable overlaps itself. Either the complete cable or individual wires can be wrapped through the ferrite.



Figure 2-17: Installing Clamp Ferrite

Wrapping should be done as close to the enclosure as possible.

Option Board Cabling

In order to prevent electromagnetic interference, when installing option boards (especially Analog Load Cell boards) in the terminal, twist the loose wires together, as shown in Figure 2-18, before attaching the green connector to the board.

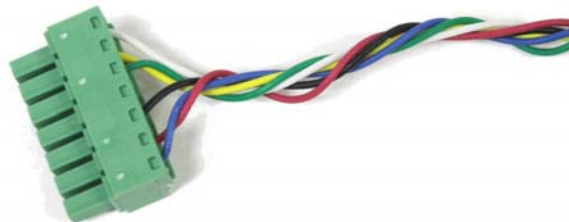

Figure 2-18: Option Board Wires Twisted

On the IND780 panel mount enclosure, cable shield terminations can be made using the strain relief cable clamp provided on the back cover. Fold the shield braid back evenly over the cable's insulation sheath and then fasten down the cable and shield with the clamp and screw onto the back cover (Figure 2-19).

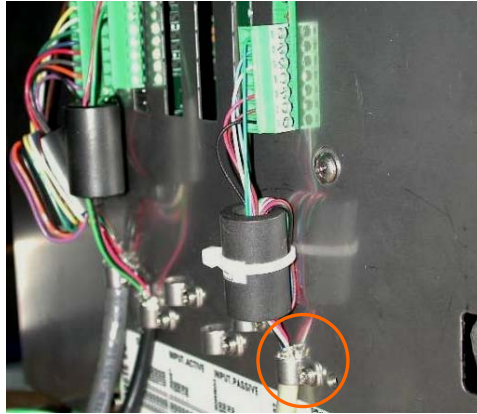

Figure 2-19: Shield Wire Termination, Panel Enclosure

Analog load cell and POWERCELL PDX cable shield termination on the IND780 harsh enclosure can be made using the metal cable gland and grommet as shown in Figure 2-24 and Figure 2-48, respectively. Other cables' shield termination can be made on the ground stud inside the enclosure (Figure 2-20).

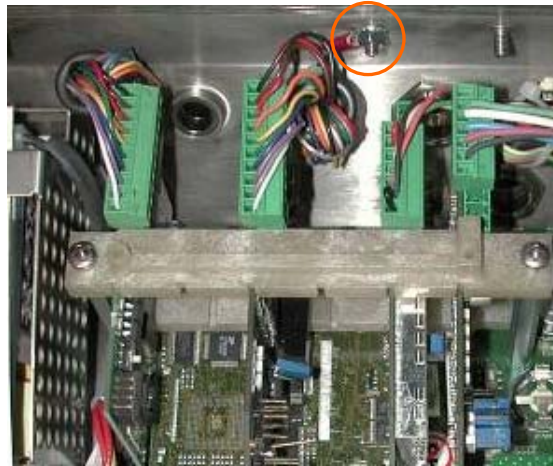

Figure 2-20: Shield Wire Termination, Harsh Enclosure

Harsh Enclosure Cable Glands and Cable Assignments

On the IND780 panel mount enclosure, cable shield terminations can be made using the strain relief cable clamp provided on the back cover. Fold the shield braid back evenly over the cable's insulation sheath and then fasten down the cable and shield with the clamp and screw onto the back cover (Figure 2-19).

Harsh Enclosure Cable Openings

Figure 2-21 and Table 2-1 show the uses and cable size limits of the various openings in the back of the harsh enclosure. The pattern code is included for ease of reference.

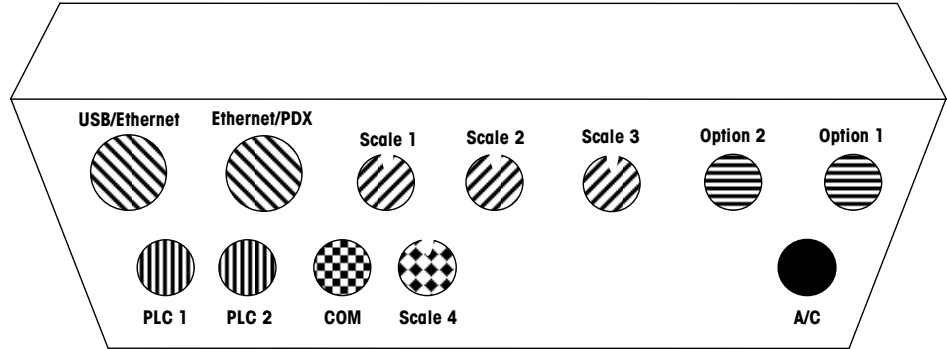

Figure 2-21: Harsh Enclosure Cable Opening Assignments

Table 2-1: Harsh Enclosure Cable Openings

Pattern	Description/Use	Cable Size Limits inches and [mm]
	USB and Ethernet connections. 25 mm plastic cable gland	0.20–0.43 [5–11] 0.51–0.71 [13–18]
	POWERCELL PDX. 16 mm metal cable gland	0.24–0.31 [6–8]
	Analog Load Cell. 16 mm metal cable gland	0.24–0.31 [6–8]
	POWERCELL PDX. 16 mm metal cable gland	0.31–0.39 [8–10]
 	Scales 1-4, IDNet (proprietary connector)	N/A
	Discrete I/O and Serial cables. 16 mm plastic cable gland	0.16–0.32 [4–8]
	Analog Output. 16 mm metal cable gland	0.24–0.31 [6–8]
	A-B RIO / PROFIBUS connectors – one in, one out	N/A
	COM1 or COM2	0.16–0.32 [4–8]
	Fourth scale connector or, with insert, COM2	0.16–0.32 [4–8]

Once any scale interfaces are installed and cabled, flow meters can use any of the Scale and Option openings.

Installing Cables

The IND780 harsh environment terminal is designed to withstand severe washdown environments. However, care must be taken when installing cables and/or connectors that enter the terminal enclosure. To ensure a watertight seal:

- Disassemble an appropriately sized cable grip. Figure 2-22 shows the components, including the blank used when no cable is present.



Figure 2-22: Cable Gland Components

- Before connecting the wires, pass the cable through an appropriately sized cable grip and into the enclosure. Then, if required, place a grommet around the cable as shown in Figure 2-23.



Figure 2-23: Cable Inserted Through Grommet, Nut, and Cable Grip

- A metal cable gland is provided with the Analog Load Cell and POWERCELL PDX options. To further protect the IND780 from external influences, the cable's shield wire can be spread out and pressed into cable gland by the grommet, as shown in Figure 2-24.



Figure 2-24: Installing Metal Cable Gland with Shield Wire

- Press the grommet into the body of the cable grip, as shown in Figure 2-25.



Figure 2-25: Grommet in Body of Cable Grip

- Move the cable through the grommet to adjust its length within the enclosure. When making cable terminations inside the harsh enclosure, ensure that the cable length from the terminal strip/connector to the terminal housing is sufficient so that no strain is placed on the connector assembly when the housing is in the fully open position.
- Finally, tighten the nut onto the body of the cable grip. Figure 2-26 shows the assembled cable grip.



Figure 2-26: Cable Grip Assembled

- After making the wiring connections as described in the next section, check that the nut on the cable gland is tightened properly to seal around the cable. Ensure that this seal is watertight.

Main PCB

Main Board Wiring Connections

The following connections are made to the IND780 main board:

- Ethernet
- USB
- COM1
- COM2
- Optional scale interface boards
- Optional serial communications boards
- Optional discrete Input / Output boards
- Optional Flow Meter interface boards
- Optional PLC interface board

The harsh enclosure must be opened to make the connections, as shown in Figure 2-27. The rear cover of the panel mount enclosure (Figure 2-28) needs to be removed in order to make these connections. Note that the option board sockets shown at the top of these figures represent the locations where option cards (Discrete I/O, Serial Communications, Flow Meters, IDNet, Analog Load Cell and POWERCELL PDX Interfaces) would be installed. These may not be present in your unit.

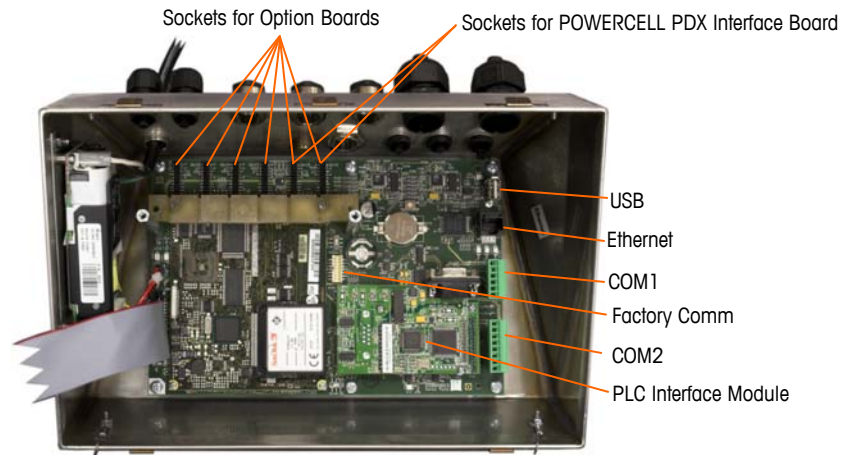

Figure 2-27: Wiring Connections, Top View, Harsh Enclosure

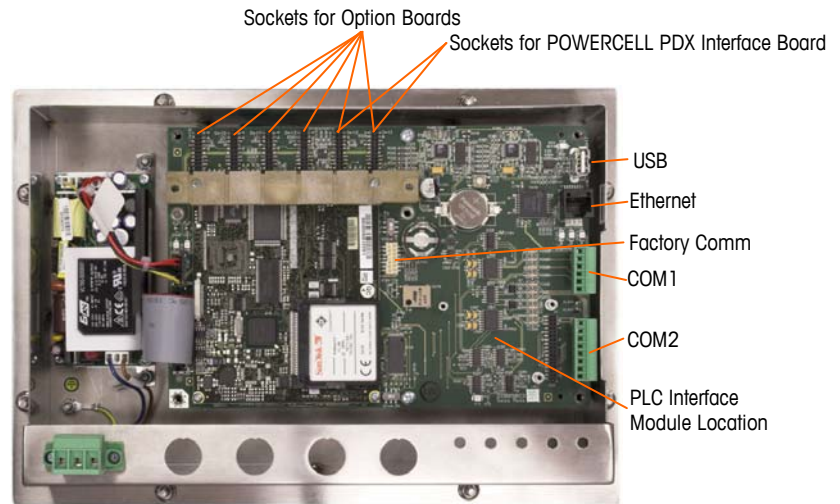

Figure 2-28: Wiring Connections, Top View, Panel Mount Enclosure

Power Connection

A permanently attached line cord supplies AC power to the harsh enclosure version of the IND780 terminal. The panel mount enclosure does not provide an AC power cord – it is designed to have AC wiring connected to the AC power connector, which is plugged into the mating connector on the rear of the chassis. Figure 2-29 shows the connector and indicates the correct assignments for neutral, ground and line wires.

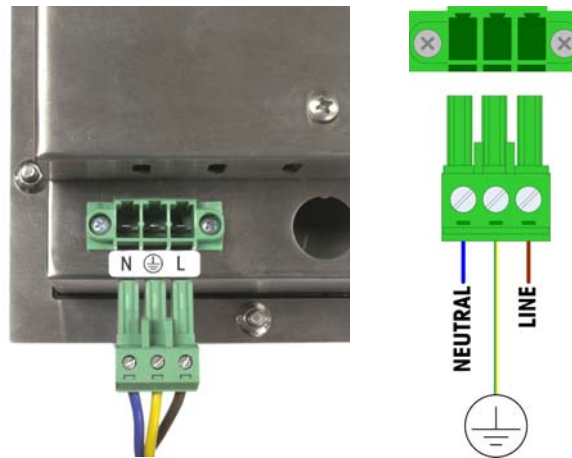

Figure 2-29: Power Connector, Panel Mount Enclosure

Power connector screws should be tightened to between 4.4 and 5.3 inch-pounds (0.5 and 0.6 Newton-meters) of torque.

No voltage or frequency settings are required since the terminal includes a universal power supply that operates from 100 to 240 VAC.

- ▀ The integrity of the power ground for equipment is important for both safety and dependable operation of the terminal and its associated scale base. A poor ground can result in an unsafe condition should an electrical short develop in the equipment. A good ground connection minimizes extraneous electrical noise pulses. The IND780 Q.iMPACT should not share power lines

with noise-generating equipment. To confirm ground integrity, use a commercial branch circuit analyzer. If adverse power conditions exist, a dedicated power circuit or power line conditioner might be required.

	<p style="text-align: center;"> WARNING</p> <p>FOR CONTINUED PROTECTION AGAINST SHOCK HAZARD CONNECT TO PROPERLY GROUNDED OUTLET ONLY. DO NOT REMOVE THE GROUND PRONG.</p>
-----------------------------------------------------------------------------------	---------------------------------------------------------------------------------------------------------------------------------------------------------------------------------------------------------------------------------------------------------------------------

Power Requirements

The terminal requires 100 to 240 VAC (at 400 mA maximum) with a line frequency of 49 to 61 Hz of power.

Ethernet and USB Connections

The IND780 Q.iMPACT's Ethernet connection provides a 10/100 base T connection (10/100 Mb) via a standard RJ45 connector.

The standard ST30 USB connector allows USB-supported peripherals, such as keyboards, to be attached to the IND780 Q.iMPACT.

Figure 2-30 shows the locations of the Ethernet and USB connectors on the main PCB. In this case, the PCB is mounted in a Panel enclosure.

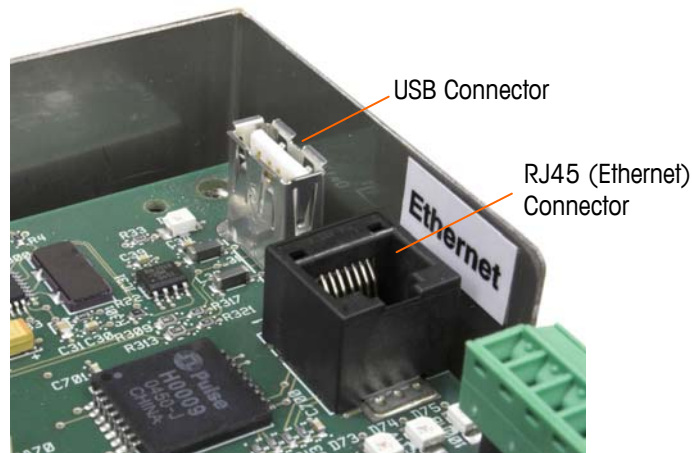

Figure 2-30: Ethernet and USB Connections

COM1 and COM2 Serial Port Connections

The COM1 port includes connections for RS232, while COM2 supports connections for RS-232, RS-422 and RS-485. The Interface parameter (in Setup at Communication > Serial) must be set to match the hardware connection used. This parameter controls how the transmit and receive lines are controlled.

COM1 Serial Port

Figure 2-31 indicates which terminal represents which signal on the COM1 Port, and Figure 2-32 shows how the port is wired for an RS232 connection. Make the

connections as necessary. Table 2-2 describes the functions for each signal in the COM1 port connector.

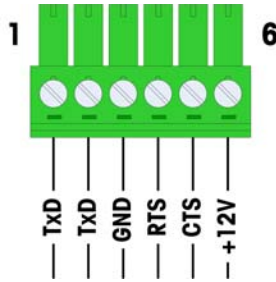

Figure 2-31: COM1 Port Connector

Table 2-2: COM1 Port Connections

Pin	Signal	Function
1	TxD	RS-232 Transmit data
2	RxD	RS-232 Receive data
3	GND	RS-232 Signal ground
4	RTS	RS-232 Request to send
5	CTS	RS-232 Clear to send
6	+12V	+12V Out, <0.5 A

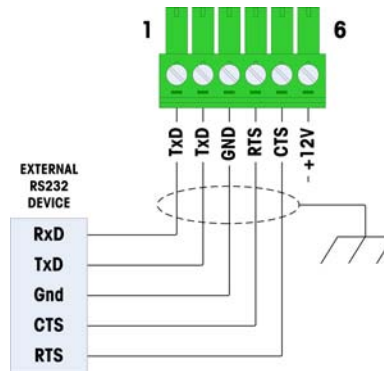

Figure 2-32: COM1 Wiring for RS232

COM2 Serial Port

Details for COM2 are provided in Figure 2-32 and Table 2-3.

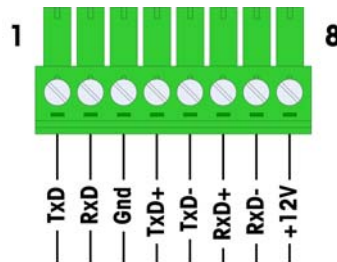

Figure 2-33: COM2 Port Connections

Table 2-3: COM2 Port Connections

Pin	Signal	Function	Notes
1	TxD	RS-232 Transmit data	
2	RxD	RS-232 Receive data	
3	GND	RS-232 Signal ground	
4	TxD+	RS-422/485 Transmit +	Jumper to RxD+ for RS-485
5	TxD-	RS-422/485 Transmit -	Jumper to RxD- for RS-485
6	RxD+	RS-422/485 Receive +	Jumper to TxD+ for RS-485
7	RxD-	RS-422/485 Receive -	Jumper to TxD- for RS-485
8	+12V	+12V Out, <0.5 A	

Some examples of connecting external equipment are shown in Figure 2-34.

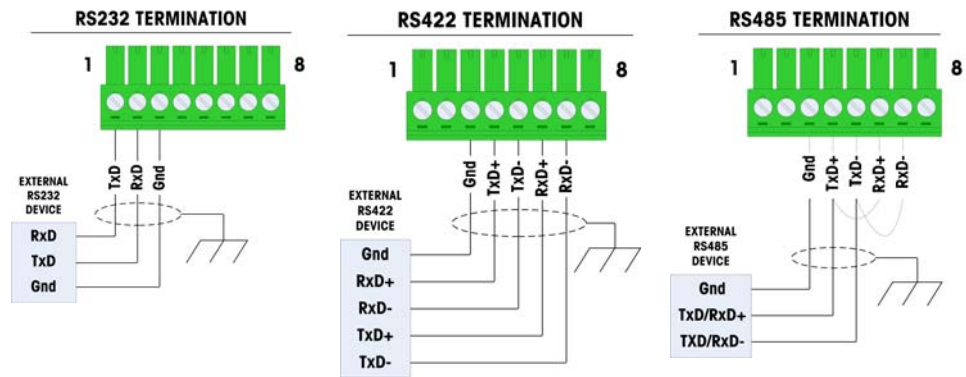

Figure 2-34: COM2 Wiring for External Equipment

RS-485 Transmission Line Termination

The RS-485 network should include a terminating resistor, installed between the two lines at or on the last node. The terminating resistor should match the characteristic impedance of the transmission line, approximately 120 ohms. This terminating resistor is required when connecting ARM100 modules to the port.

Switch Settings

Two switches are located on the main PCB in the positions indicated in Figure 2-35. These switches' functions are explained in Table 2-4.

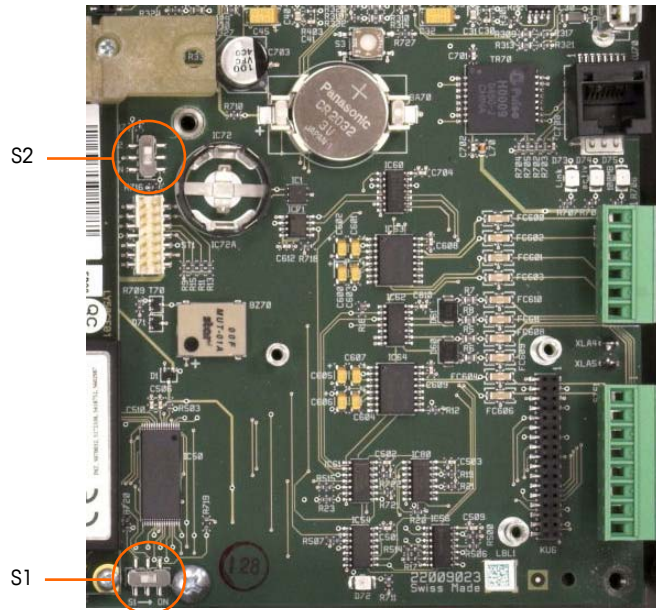

Figure 2-35: Main PCB Switch Locations

Table 2-4: Main PCB Switch Functions

Switch	Function
S-1	Metrology Security Switch. When in the ON (right) position, this switch prohibits access to Scale settings in the menu and other metrologically significant areas.
S-2	Task Expert Disable Switch. When in the ON (down) position, disables the task expert auto-start feature. This is used primarily for maintenance purposes.

Note that the switches shown in Figure 2-35 are both in their OFF position.

Master Reset Button

To erase all programming in the terminal and reset all settings (except metrologically significant scale calibration data) to their factory default values, press the master reset button adjacent to the battery. Figure 2-36 indicates the location of this button. This process is described in the **IND780 Technical Manual**, Chapter 4.0, **Service and Maintenance**.

- To reset scale data as well, S2 (shown in its OFF position in Figure 2-36) must be set to ON before the master reset.



Figure 2-36: Main PCB Master Reset Button Location

LED Interpretation



Figure 2-37: Main PCB LEDs

Table 2-5: Main PCB LEDs

LED	Color	Function
D12	Yellow	Indicates 12V supply is present.
D13	Yellow	Indicates 5V supply is present.
D30	Green	When lit, indicates USB port has been identified and is functional. ■ Note that this LED remains lit whether or not a USB device is connected.
D72	Amber	Used for software development purposes; blinking during normal system operation.
D73	Yellow	Indicates that an Ethernet connection exists.
D74	Green	When blinking, indicates that the Ethernet connection is actively receiving or transmitting data.
D75	Red	When lit, indicates that Ethernet connection is 100 MB. D73 lit, D75 off, indicates that Ethernet connection is 10 MB.

ETX Board

The ETX board features a single, green LED, mounted beneath the lower card guide. Its approximate location is indicated in Figure 2-37. When power is supplied to the board, this LED is lit steadily, indicating that the core power supply is on. This in turn indicates that both on-board regulators are functioning correctly.

Option Boards

Configuration and Connection of Options

Options available for the IND780 Q.iMPACT terminal include the following:

- Analog Load Cell
- POWERCELL[®] PDX[®]
- IDNet interface
- Flow Meter Interface
- FCE Wiring with Analog Load Cell
- Serial Communications
- DeviceNet
- PROFIBUS (Harsh Enclosure)
- PROFIBUS (Panel Enclosure)
- ControlNET
- Ethernet/IP and Modbus TCP
- Rockwell (Allen-Bradley) RIO
- Discrete I/O (Relay) and Solid State Relay

Figure 2-38 shows each of these options, together with its location in the terminal. The connections and board settings for each option are described in the following sections.

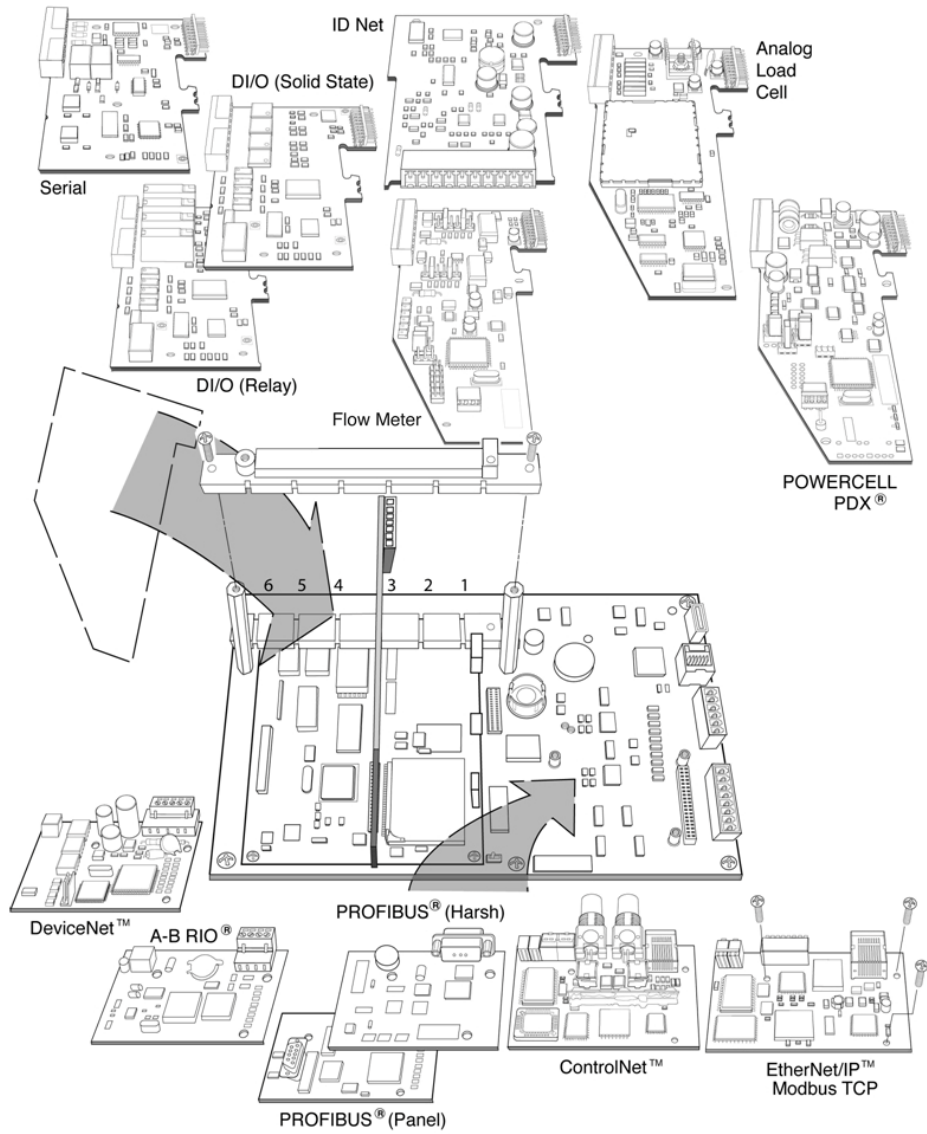

Figure 2-38: IND780 Q.iMPACT Options Locations

Analog Load Cell

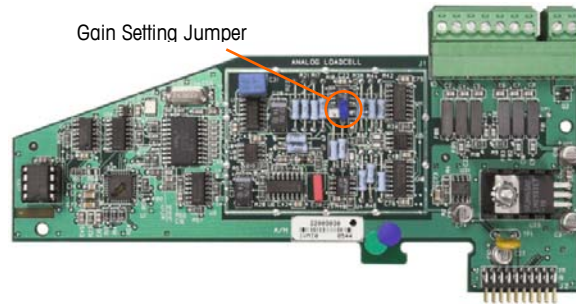

Figure 2-39: Analog Load Cell Option Board

Jumper Settings

One jumper (W1) on the IND780 Q.iMPACT analog scale option board permits the gain of the analog section to be set to either 2 mV/V or 3 mV/V. The factory default is 3 mV/V, which normally will work well for both 2 mV/V and 3 mV/V load cells. If 2 mV/V load cells are used, the jumper can be changed to the 2 mV/V position. Figure 2-40 shows the jumper's location and settings on the board.

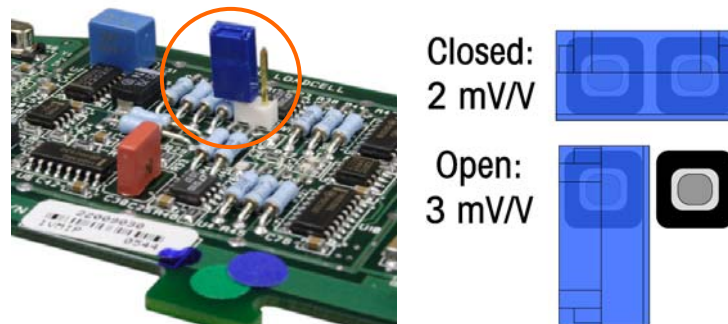

Figure 2-40: Analog Load Cell Board Millivolt Jumper Location and Settings

The 2 mV/3 mV jumper settings are described in Table 2-6.

Table 2-6: Millivolt Jumper Description

Jumper	On	Off	Description
W1	X		When the jumper is closed, the connected scale's load cell setting is 2 mV/V.
		X	When the jumper is open, the connected scale's load cell setting is 3 mV/V

Connections



WARNING!

TO AVOID DAMAGE TO THE PCB OR LOAD CELL, REMOVE POWER FROM THE IND780 Q.iMPACT TERMINAL AND WAIT AT LEAST 30 SECONDS BEFORE CONNECTING OR DISCONNECTING ANY HARNESS.

When using the IND780 Q.iMPACT with one or more analog load cells, load cell connections are made to the connector located on the Analog Load Cell option board. The 7-position connector is visible at top right in Figure 2-39, with the board's 2-position discrete output connection next to it. Note that for clarity the board's socket is shown with two (unwired) connectors plugged into it.

- When installing Analog Load Cell boards, to prevent electromagnetic interference twist the connector wires before attaching the connector to the board.

Analog Load Cell boards may be placed in any of slots 1 through 4, for a total of four scales. The IND780 Q.iMPACT can power as many as 16 load cells.

The IND780 Q.iMPACT terminal is designed to power up to eight 350-ohm load cells (or a minimum resistance of approximately 43 ohms) per card. To confirm that the load cell load for this installation is within limits, the total scale resistance (TSR) must be calculated. To calculate TSR:

$$\text{TSR} = \frac{\text{Load Cell Input Resistance (ohms)}}{\text{Number of Load Cells}}$$

Ensure that the TSR of the load cell network to be connected to the IND780 Q.iMPACT has a resistance greater than 43 ohms before connecting the load cells. If the resistance is less than 43 ohms, the IND780 Q.iMPACT will not operate properly.

In addition, the maximum cable distance must be reviewed. Table 2-7 provides recommended maximum cable lengths based on TSR and cable gauge.

Table 2-7: Recommended Maximum Cable Lengths

TSR (Ohms)	24 Gauge (meters/feet)	20 Gauge (meters/feet)	16 Gauge (meters/feet)
350	243/800	610/2000	1219/4000
87 (4-350 Ω cells)	60/200	182/600	304/1000
43 (8-350 Ω cells)	30/100	91/300	152/500

Figure 2-41 shows wiring definitions for the analog load cell connector. Note that when using four-wire load cells, jumpers must be placed between the +Excitation and +Sense terminals and between the Excitation and Sense terminals.

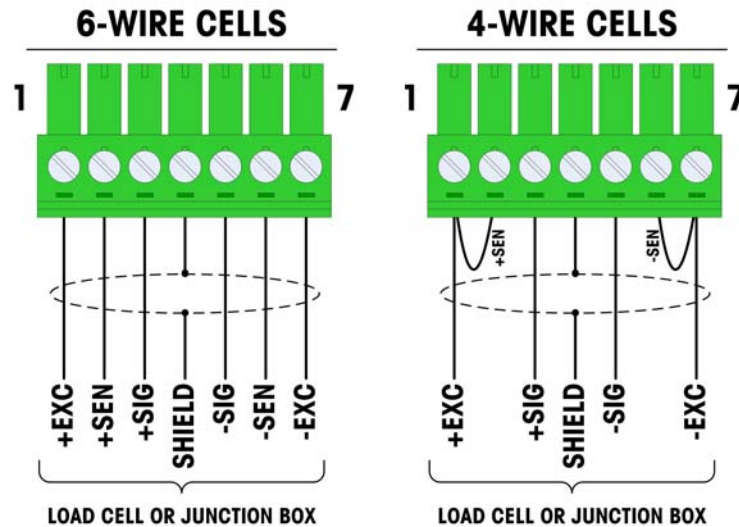

Figure 2-41: Load Cell Connections

- Note for the standard four-wire cable: If an increase in load results in a decrease in weight display, reverse the signal wires (+SIG and -SIG).

Figure 2-42 shows wiring definitions for the analog load cell discrete output connector.

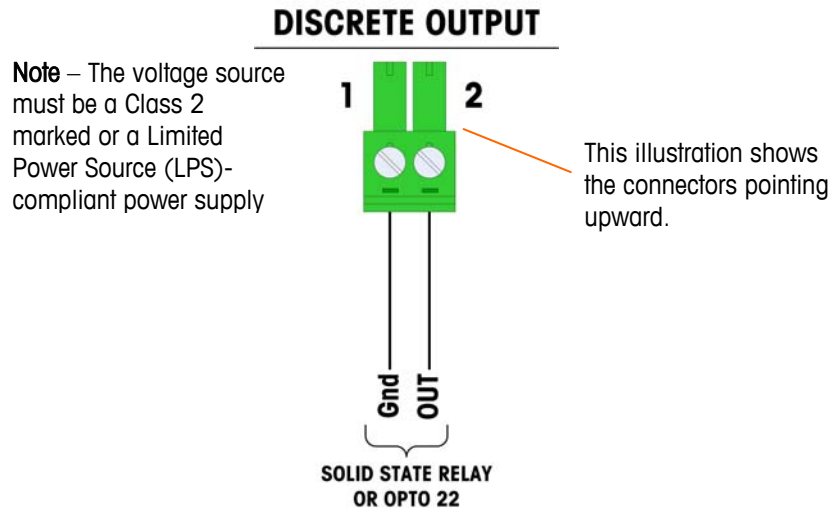

Figure 2-42: Analog Load Cell Discrete Output Connector

The TTL-compatible open collector output is reserved for use only with the scale’s material transfer target functionality. It provides the signal for the feed output associated with the active target for that scale. It is not necessary to configure this output. The output is a current-sinking component which can handle from 5 to 30 volt DC signals at a maximum of 35 mA current. A solid-state relay or OPTO 22 is typically connected to buffer the IND780 Q.iMPACT terminal outputs to a 120 or 220 volt AC signal.

FCE (Final Control Element) Wiring using Analog Load Cell Board

Figure 2-43 illustrates the method of connecting a valve (Final Control Element/FCE) using the Analog Load Cell card and IND780 Q.iMPACT COM2 port. Note that it is up to the user to provide adequate circuit protection (circuit breakers or fusing) in accordance with any applicable Electrical Codes for their installation.

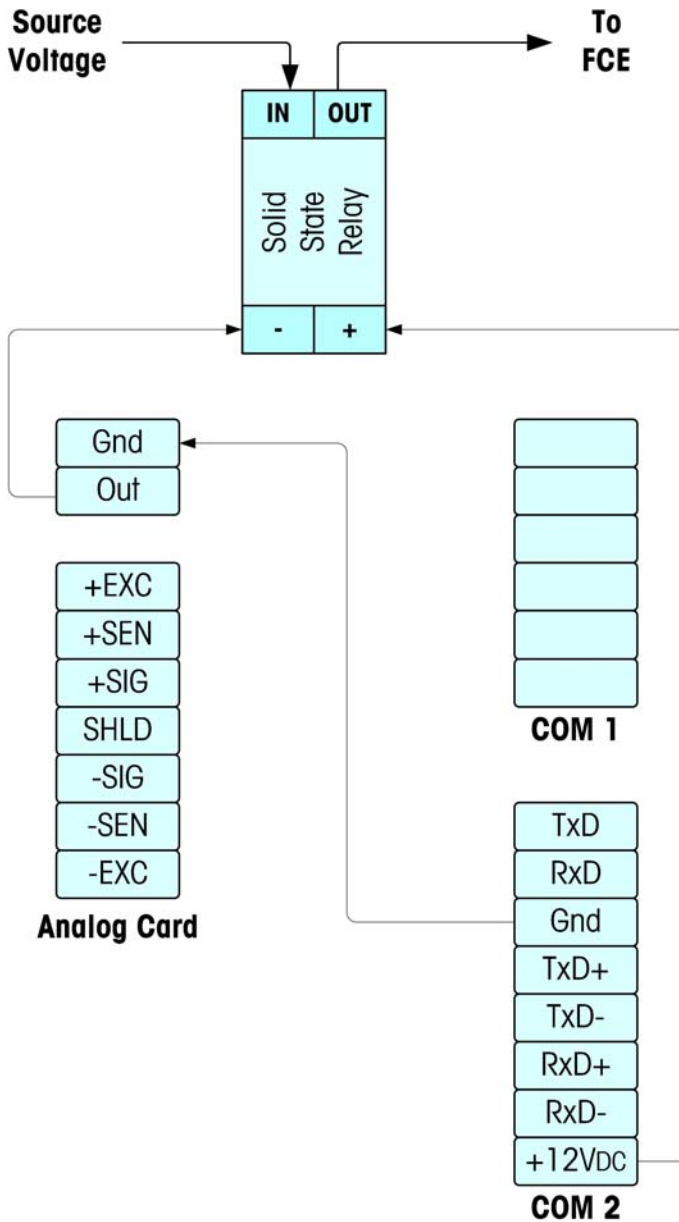

Figure 2-43: FCE Wiring using Analog Load Cell Card and COM2 Port

LED Interpretation

Figure 2-44 indicates the location of LED on the Analog Load Cell board.



Figure 2-44: Analog Load Cell LED

Table 2-8: Analog Load Cell LED

LED	Color	Function
USB	Amber	Slow blink (~1 Hz) indicates no USB communication with Main PCB Fast blink (~4 Hz) indicates USB communication with Main PCB is operating properly

POWERCELL PDX

Jumper Settings

The POWERCELL PDX[®] board has several jumpers. The W6 jumper is used to set in the POWERCELL PDX network's terminating resistor on the IND780 Q.iMPACT. Figure 2-45 shows the jumpers' locations and settings. Table 2-9 describes the purpose of each setting.

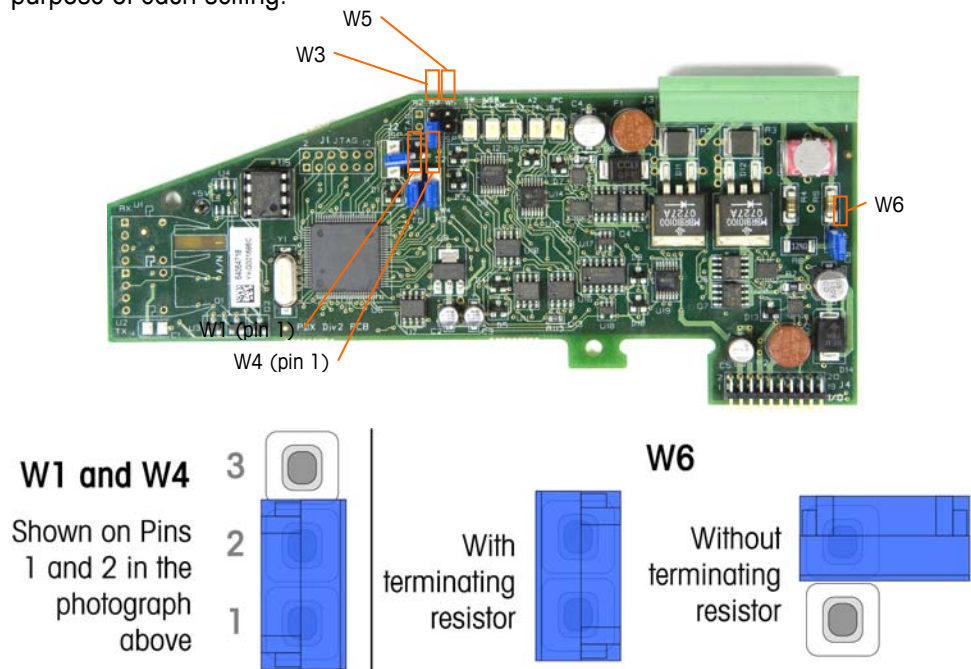

Figure 2-45: POWERCELL PDX Board Jumper Locations and Settings

Table 2-9: POWERCELL PDX Board Jumper Description

Jumper	On	Off	Description
W3		X	Always set to off in normal operation (factory use).
W5		X	Always set to off in normal operation (factory use).
W6	X		Set this jumper on to install a POWERCELL PDX network terminating resistor. Should be on in normal operation.
		X	Remove this jumper if a network terminating resistor is not to be installed in the terminal.
Pins			
W1	1, 2		Jumper pins 1 and 2 in normal operation. (reserved)
W4	1, 2		Jumper pins 1 and 2 in normal operation. (reserved)

Connections

WARNING!

TO AVOID DAMAGE TO THE PCB OR LOAD CELL, REMOVE POWER FROM THE IND780 Q.iMPACT TERMINAL AND WAIT AT LEAST 30 SECONDS BEFORE CONNECTING OR DISCONNECTING ANY HARNESS.



WARNING!

THE POWERCELL PDX SCALE INTERFACE BOARD #64064718 (KIT NUMBER 64067252) MUST NOT BE USED IN AN IND780 Q.iMPACT TERMINAL INSTALLED IN AN AREA CLASSIFIED AS DIVISION 2 OR ZONE 2/22. FAILURE TO COMPLY WITH THIS WARNING COULD RESULT IN BODILY HARM AND/OR PROPERTY DAMAGE.

The POWERCELL PDX option board should be placed in slot 1 or slot 2 on the main board. This option is used with METTLER TOLEDO POWERCELL® PDX® load cells used in large tank and vehicle weighing applications. Figure 2-46 shows a POWERCELL PDX option board. Only one POWERCELL PDX option board can be installed in the terminal, to support up to four scales.



Figure 2-46: POWERCELL PDX Option Board

Figure 2-47 shows the terminal strip connections for this board.

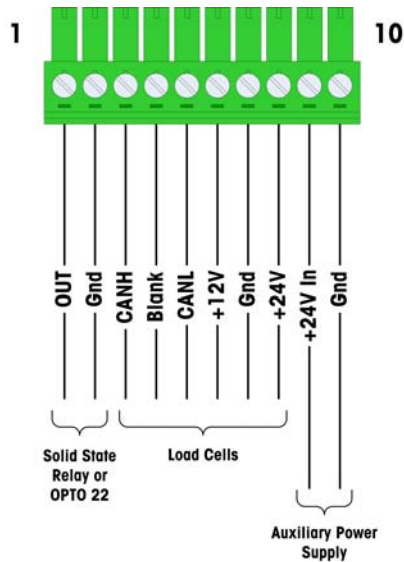

Figure 2-47: POWERCELL PDX Option Board Connections

The TTL-compatible open collector output is reserved for use only with the scale’s material transfer target functionality. It provides the signal for the feed output associated with the active target for that scale. It is not necessary to configure this output. The outputs are current-sinking components which can handle from 5 to 30 volt DC signals at a maximum of 35 mA current. A solid-state relay or OPTO 22 is typically connected to buffer the IND780 terminal outputs to a 120 or 220 volt AC signal.

Depending on the number of load cells and the cabling configuration, the IND780 Q.iMPACT terminal uses either its internal 12 VDC supply (via pins 6 and 7) or an external 24 VDC supply (via pins 7 and 8) to power the load cells. Refer to Table 2-10 for the recommended maximum cable lengths and the number of load cells supported by the IND780 Q.iMPACT POWERCELL PDX option board when using its internal 12 VDC supply.

Table 2-10: Recommended Maximum Cable Lengths (for +12 VDC)

Total Cell-Cell Cable (meters/feet)	Home Run Cable (meters/feet)	Number of PDX Cells
60/197	300/984	≤ 8
80/262	250/820	≤ 10
85/278	200/656	≤ 12
100/328	100/328	≤ 12
100/328	85/278	≤ 14
140/459	50/164	≤ 14

When the terminal is used with cable lengths exceeding those given above or with more than 14 POWERCELL PDX cells, it is recommended to install the optional external 24 VDC power supply (P/N 0917-0240). With the external supply, it is possible to use up to 24 load cells per terminal, a maximum home run cable

length of 300 m (984 ft) and a total of 200 m (656 ft) of cell-to-cell cable. The external power supply is connected to pins 9 and 10 on the PDX board.

Home Run Cable Grounding and Shielding

Ground and shield terminations are a critical part of the system's immunity to noise and electrical surges. To prepare for the terminations on the home run cable:

1. Cut and remove an appropriate length of the outer braid shield and the insulation sheath, ensuring that there is sufficient length to provide strain relief for the connection of the wires to the option board.
2. Trim the inner braid shield and the foil, leaving about 20 mm (0.8 inches) exposed.
3. When installing an IND780 Q.iMPACT harsh enclosure terminal:
 - a. Install the cable gland assembly, metal clamp and the brass sleeve onto the home run cable while sliding back the outer braid shield (Figure 2-48). The inner drain wire should go into the enclosure through the cable gland, while the outer drain wire remains on the outside.
 - b. Fold and spread out the inner braid shield and foil over the metal ring before pressing the grommet into the body of the cable gland, as shown in Figure 2-48. Tighten the cable gland's nut with the brass sleeve onto the body of the gland.

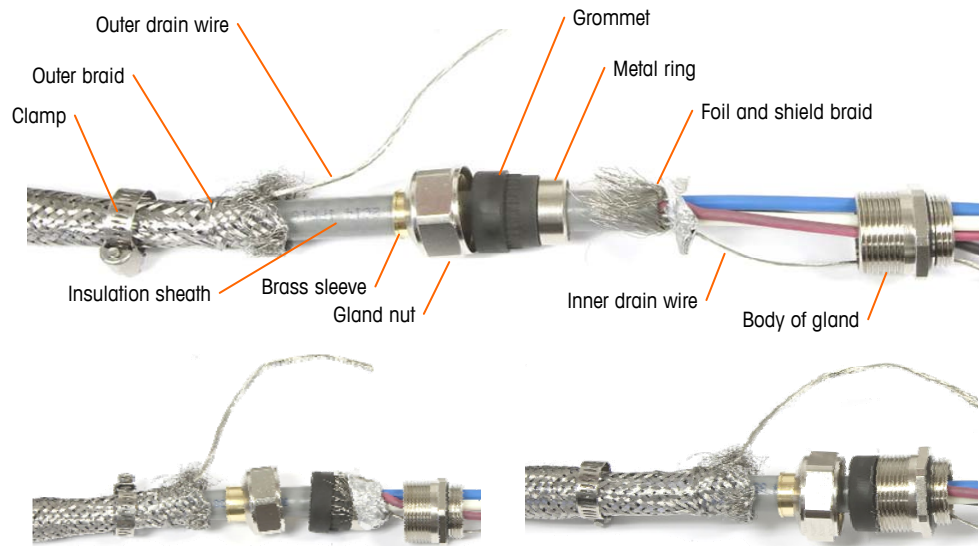

Figure 2-48: PDX Home Run Cable and Gland Assembly

- c. Pull the outer braid forward to cover the brass sleeve and wrap one end of a flat braided ground cable over it before securing everything down using the metal clamp (Figure 2-49). Route the home run cable's outer drain wire along with the flat braided cable through a ground lug attached to the rear of the harsh enclosure. The other end of the flat braided cable is terminated at the ground rod.

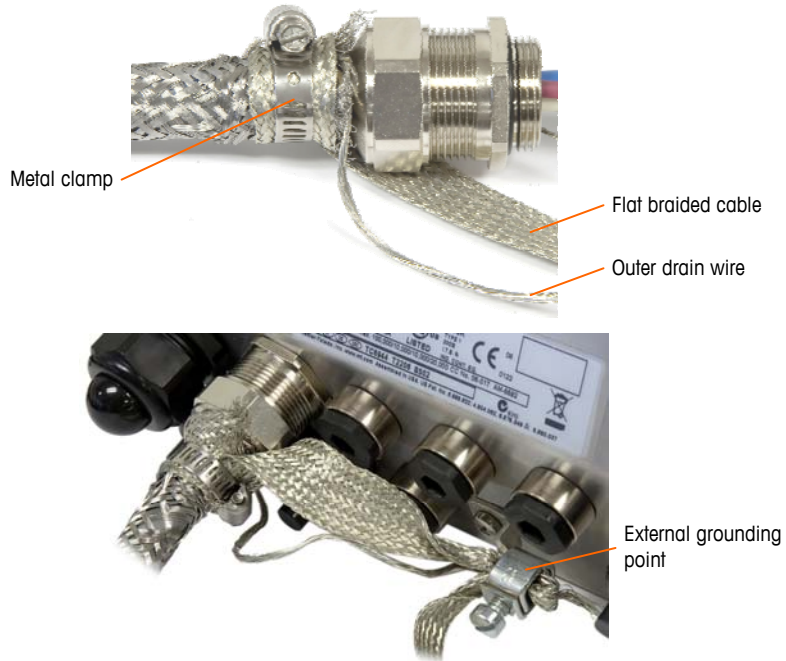

Figure 2-49: PDX Home Run Outer Braid Termination, Harsh Enclosure

4. To terminate the home run cable's outer and inner braid shield for an IND780 Q.iMPACT panel mount terminal, when using a cable gland with the external panel housing, follow the procedure described in step 3, above. Alternatively, when using a conduit hub entry:
 - a. Slide back the outer braid and fold the trimmed inner braid and foil shield back evenly over the edge of the cable insulation sheath, as shown in Figure 2-50.

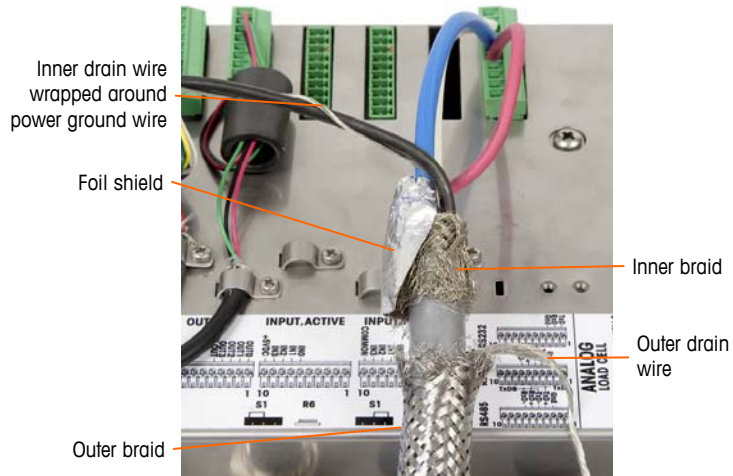

Figure 2-50: PDX Home Run Cable, Panel Mount Enclosure

- b. Slide forward the outer braid to cover over the inner braid and foil. Pull the outer drain wire back over the outer braid and trim it to approximately 25 mm (1 inch). Place the flat braided ground cable around the home run cable and the drain wire before finally securing everything to the back

cover of the IND780 Q.iMPACT using the large strain relief cable clamp provided with the unit (Figure 2-51).

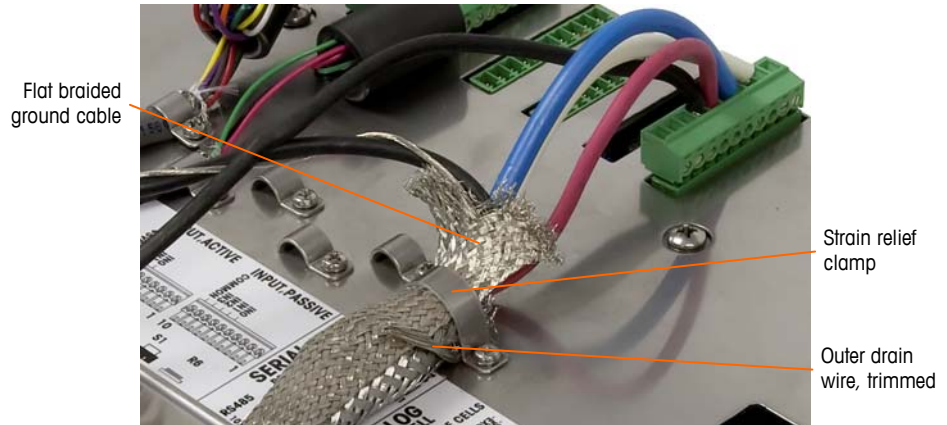

Figure 2-51: PDX Home Run Outer Braid Termination, Panel

5. For an IND780 Q.iMPACT harsh enclosure, to make the power ground connection on pin 7 of the option board terminal strip:
 - a. First, a separate short length of the power ground wire with a ring terminal on one end must be prepared in advance. Attach this separate wire with the ring terminal end to the ground stud located inside the terminal's enclosure using a hex nut. Connect the other end to pin 7 on the terminal strip.
 - b. Next, twist the home run cable's inner drain wire together with the core power ground wire and make a connection to the same ground stud using another ring terminal as shown in Figure 2-52.

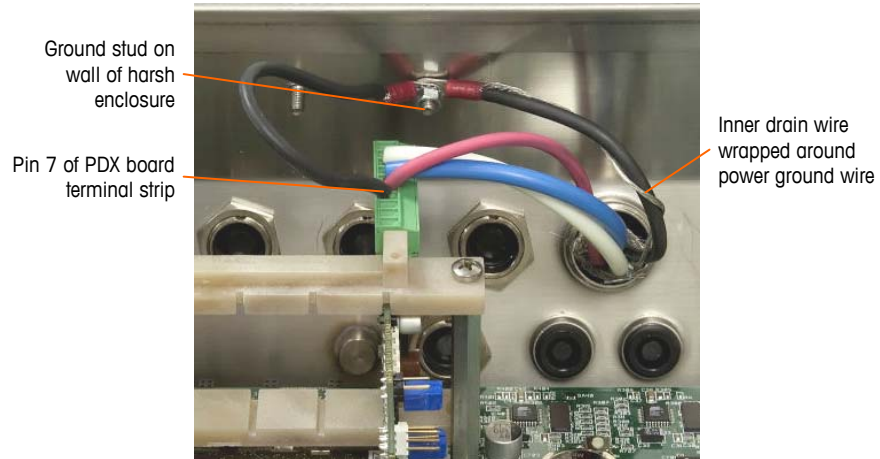

Figure 2-52: PDX Home Run Power Ground Connection, Harsh

6. For an IND780 Q.iMPACT panel mount enclosure, make the terminations described in step 5 to the external ground stud indicated in Figure 2-53.

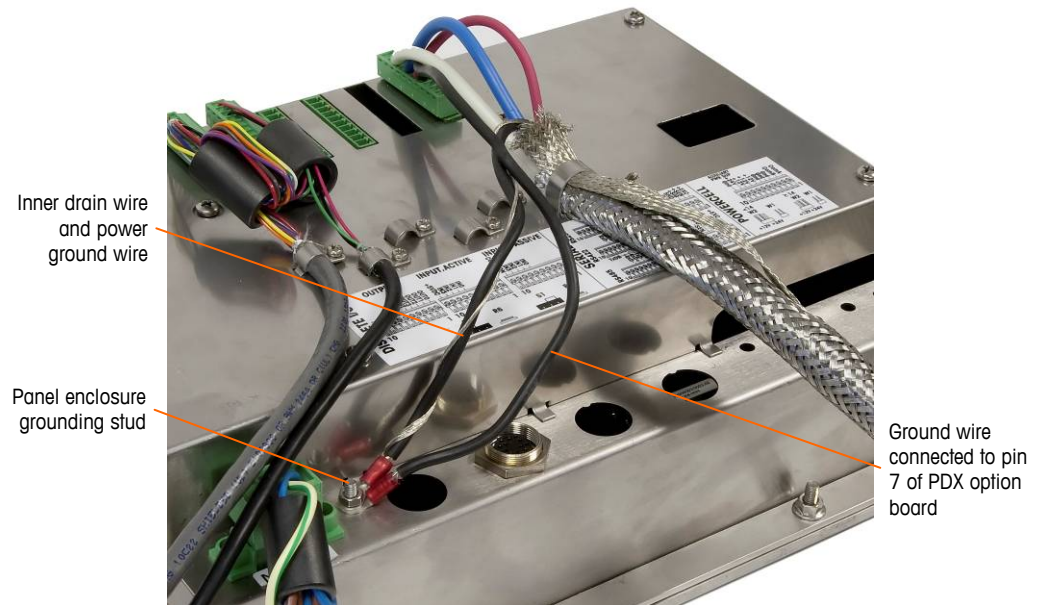

Figure 2-53: Completed PDX Home Run Power Ground Connection, Panel Mount Enclosure

Open Collector Output

The PDX option board provides a single TTL-compatible open collector output (pin 1 and pin 2), with current sinking components that can handle from 5 to 30 VDC signals at a maximum of 35 mA current. A solid state relay or OPTO 22 is typically connected to buffer the output to a 120 or 220 VAC signal. The voltage source must be a Class 2 marked or a Limited Power Source (LPS)-compliant power supply.

This output is reserved for use with the scale's material transfer target functionality. It provides the feed output signal associated with the active target for a PDX scale assigned as scale 1.

LED Interpretation

Figure 2-54 indicates the locations of LEDs on the POWERCELL PDX board. Table 2-11 describes the function of the LEDs.

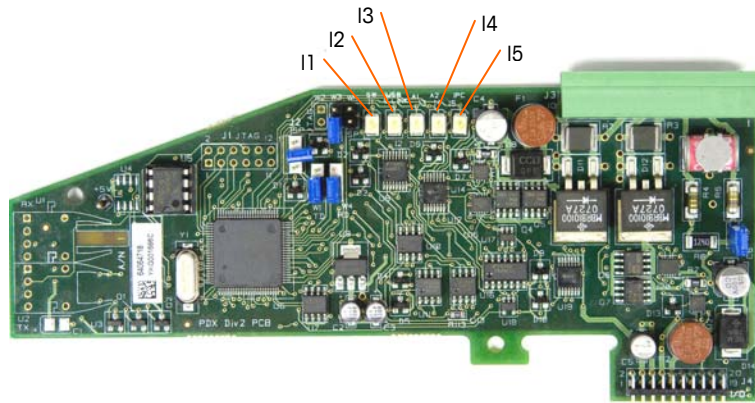

Figure 2-54: POWERCELL PDX Board LEDs

Table 2-11: POWERCELL PDX Board LEDs Indications

LED	Color	Function
I1: SW	Amber	ON – the board’s discrete output is turned on OFF – the board’s discrete output is turned off
I2: USB	Amber	ON – the USB connection to the main board is active OFF – the USB connection to the main board is inactive
I3: A1 I4: A2	Amber	I3 solid ON, I4 OFF – indicates that the CAN communication to the load cells is active I3 and/ or I4 blinking – indicates that the CAN communication to the load cells is interrupted
I5: IPC	Amber	Slow blink (~1 Hz) indicates that the board’s processor is not working correctly Fast blink (~ 3 Hz) indicates that the board’s processor is working correctly

Flow Meter Interface

The Flow Meter Option Board (Figure 2-55) is a two-channel isolated counter/flow meter board available for use with the IND780 Q.iMPACT terminal. The board provides a flow meter totalizer target comparison to directly control on-board discrete outputs.

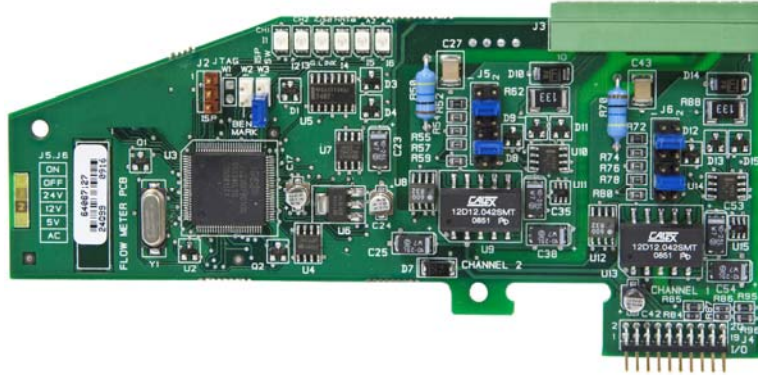

Figure 2-55: Flow Meter Interface Board

For additional details about the flow meter interface, refer to Appendix D.

Interface Wiring

The Phoenix Contact 10-pin connector pin outs are as follows:

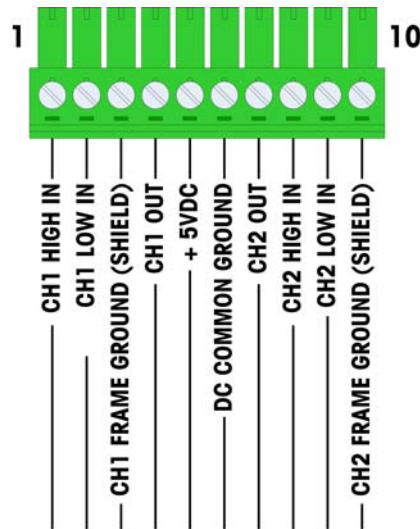

Figure 2-56: Flow Meter Connector

Pins 3 and 10 (the frame grounds for Channels 1 and 2) provide floating grounds, and are the return lines for pins 1 and 8 (the high inputs for Channels 1 and 2). This maintains the isolation of the input circuitry from the rest of the board electronics.

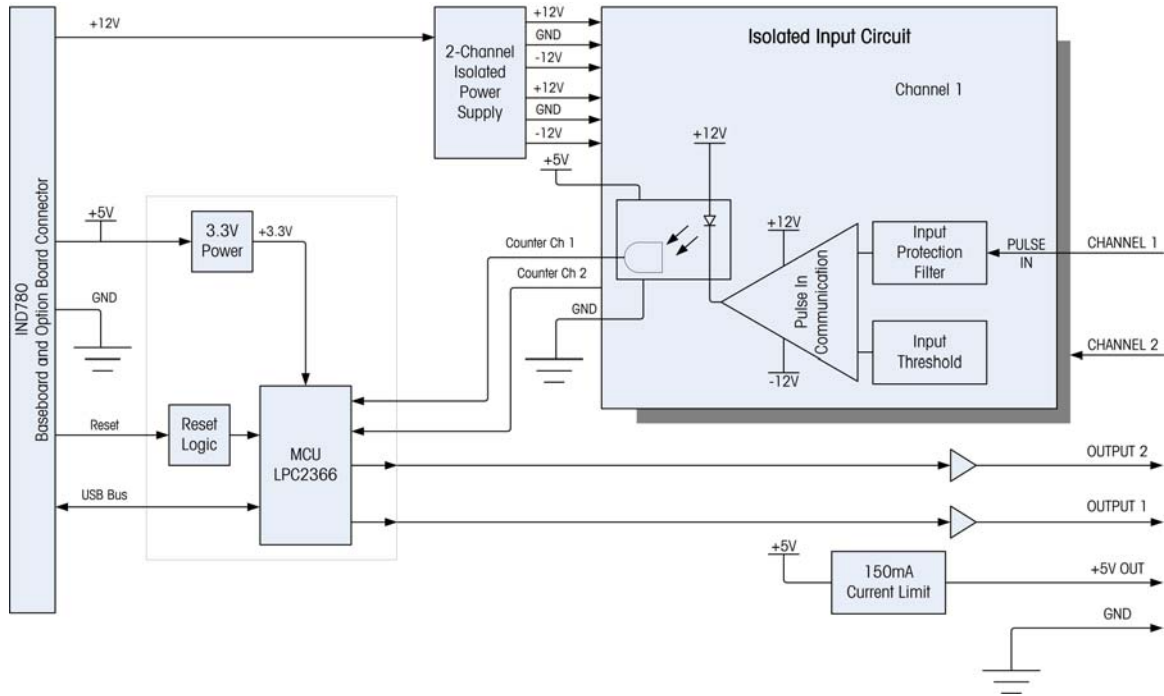

Figure 2-57: Block Diagram, Channel 1 Shown

Jumper Settings

The flow meter board has four sets of hardware jumpers, indicated in Figure 2-58.

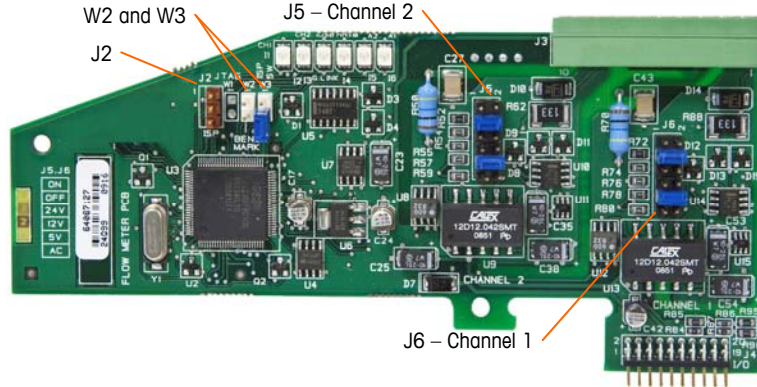

Figure 2-58: Flow Meter Interface Board Jumper Locations

J5/J6 – Filter Enable

Each of the two input channels indicated in Figure 2-58 has a set of six jumper settings, which function as shown in Table 2-12. Jumper locations 1-2 (enable) and 3-4 (disable) control the 15kHz low-pass analog filter, which is used to filter noise on the input.

Table 2-12: Settings for Jumpers J5 (Channel 2) and J6 (Channel 1)

		Function	Jumper Location	
1	2	Analog Low-Pass Filter on	1	2
3	4	Analog Low-Pass Filter off	3	4
5	6	24V Range	5	6
7	8	12V Range	7	8
9	10	5V Range	9	10
11	12	AC Range	11	12

The analog filter should be enabled in the following cases:

- For flow meter frequencies below 15 kHz
- For all AC applications, regardless of frequency

J5/J6 – Input Switching Threshold

For each channel, this jumper has four possible positions (5/6, 7/8, 9/10, 11/12), which set the comparison voltage level for the input comparator. Voltage levels are:

- 0.0 VAC – use the AC jumper selection
- 2.3 VDC – use the 5 VDC jumper selection
- 6.0 VDC – use the 12 VDC jumper selection
- 8.0 VDC – use the 24 VDC jumper selection

Please consult the documentation for the specific flow meter you intend to use.

Wiring a Flow Meter

An attached flow meter can be either isolated with respect to the Q.i output voltage, or it can be non-isolated and share a common output voltage. The circuits in Figure 2-59 and Figure 2-60 illustrate these two methods of connecting a flow meter’s pulse outputs to a Q.i flow meter interface board.

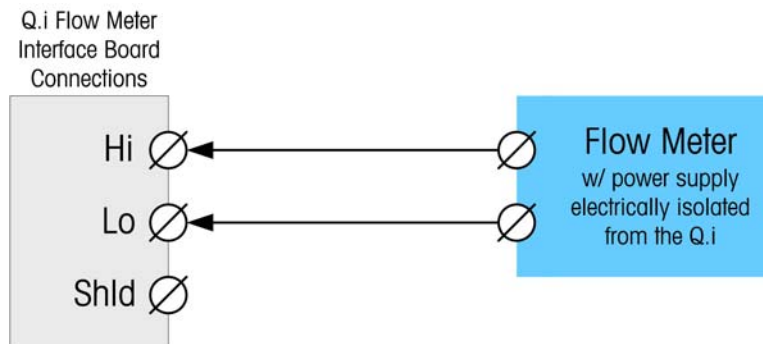

Figure 2-59: Isolated Flow Meter Connections

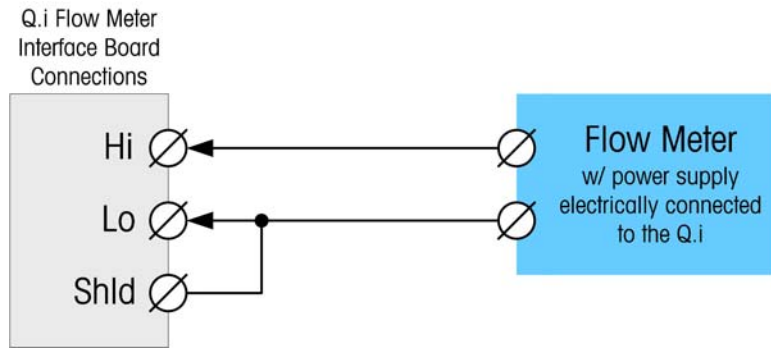

Figure 2-60: Non-Isolated Flow Meter Connections

Discrete I/O (Input/Output)

Mode Selector Switch

A switch on the Discrete I/O board selects whether the inputs will be active or passive. An explanation of these two modes and sample wiring diagrams were provided earlier in this chapter. Ensure that the switch is set properly before wiring to the inputs. The location of the switch (S1) is shown in the drawing and photograph in Figure 2-61. In both cases, the switch in the illustration is set to active.

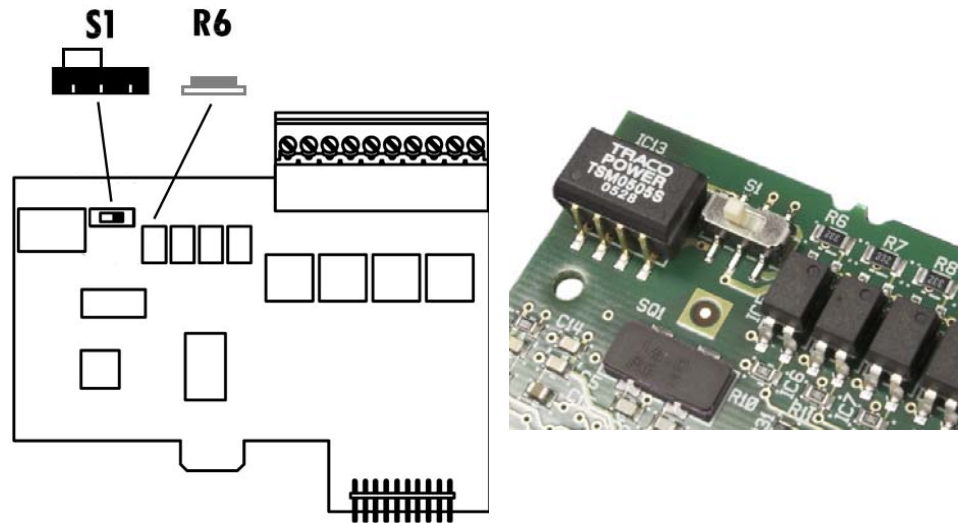

Figure 2-61: Discrete I/O Board Mode Selector Switch Location

Connections

The relay output version of the Discrete I/O option provides four isolated inputs and four dry-contact, normally open relay outputs. The inputs can be selected as either active or passive based on the position of the slide switch on the board.

Figure 2-62 and shows a Discrete I/O board in its Solid State Relay configuration, and Figure 2-63 the Relay version.

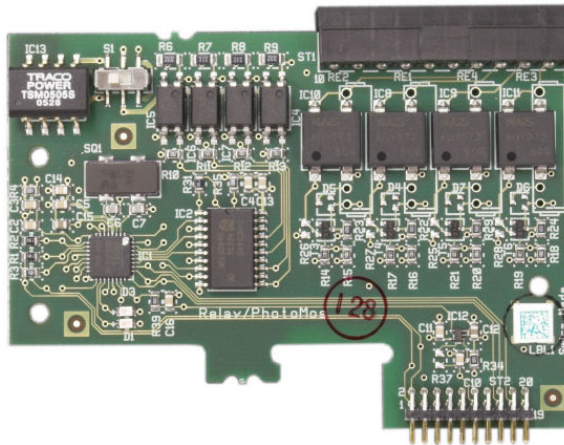

Figure 2-62: Discrete I/O Board, Solid State Relay

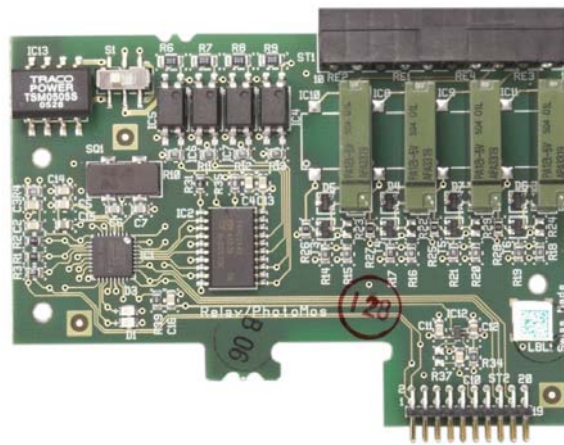

Figure 2-63: Discrete I/O Board, Relay

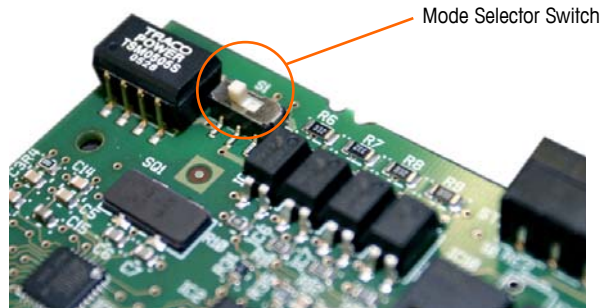

Figure 2-64: Discrete I/O Mode Selector Switch, Active Position

Active Input

Selecting the inputs as active enables connection of switches or other simple devices to trigger an input. No voltage is supplied by the external simple device. An example of how to wire to the active inputs is shown in Figure 2-65. Note that pin 10, the +5VDC connection, can carry no more than 200 mA current.

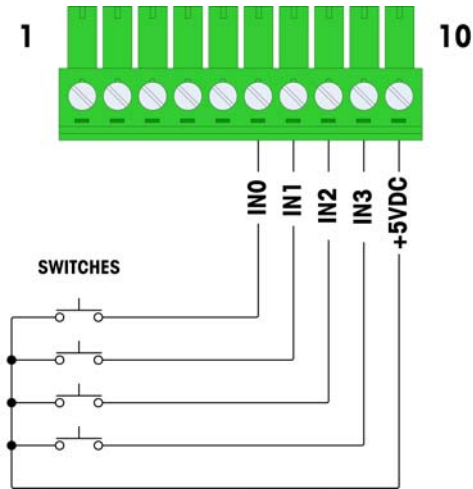

Figure 2-65: Example of Active Input from Switches

Passive Input

Selecting the inputs as passive enables other devices such as PLCs to provide the trigger voltage (typically 24 VDC, 5-30 VDC) to turn the IND780 Q.iMPACT inputs “on”. An example of wiring to the passive inputs is shown in Figure 2-66. The voltage polarity may be reversed. Furthermore, inputs can be programmed in SETUP to accept either a + True or – True polarity level as “ON”.

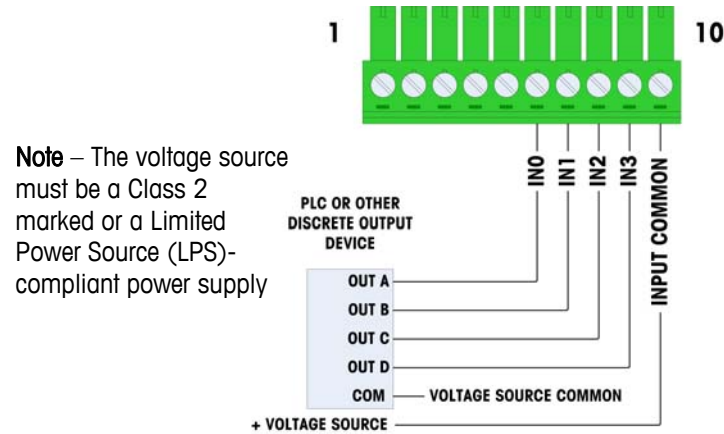

Figure 2-66: Example of Passive Input from Discrete Output Device

Relay Outputs

The relay and solid state relay outputs can switch up to 30 VAC or 30 VDC voltages at 1A maximum. The relay outputs are not polarity-sensitive since they are dry contact outputs. An example of wiring to the outputs is given in Figure 2-67.

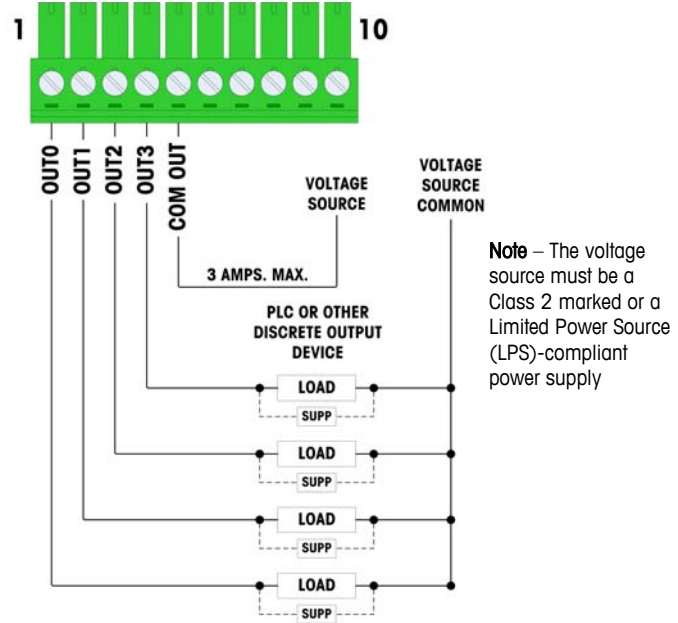

Figure 2-67: Relay Outputs

IDNet

Connections



WARNING!

TO AVOID DAMAGE TO THE PCB OR LOAD CELL, REMOVE POWER FROM THE IND780 Q.iMPACT TERMINAL AND WAIT AT LEAST 30 SECONDS BEFORE CONNECTING OR DISCONNECTING ANY HARNESS.

For IDNet base load cells, the IND780 Q.iMPACT terminal supplies 12 VDC for the new T-Brick type, and 30 VDC for the legacy PIK-Brick type. When using an IDNet card in the IND780 Q.iMPACT terminal, the cable connection from the base is made to a connector on the rear of the housing. IDNet cards are supplied with a length of cable and a connector that mates to the connector on the IND780 Q.iMPACT terminal. The board is shown in Figure 2-68.

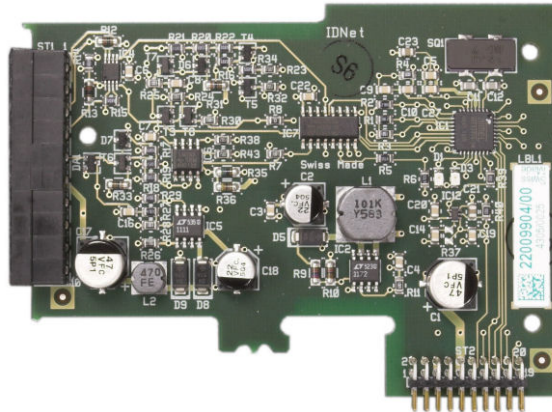

Figure 2-68: IDNet Option Board

Figure 2-69 shows the IDNet harness. One end attaches to the option board, and the threaded body of the connector mounts in one of the keyed holes in the back of the Panel or Harsh Enclosure, with its nut on the outside of the enclosure. Route the harness wire away from any Analog Loadcell Boards to protect the IND780 Q.iMPACT from external influences. Refer to Figure 2-21 and Table 2-1 for the Harsh enclosure mounting position.



Figure 2-69: IDNet Harness

The IDNet cable is required to connect between the option board and the enclosure case. The cable is configured as shown in Figure 2-70.

IDNet Cable 64062067			
P1	P2	Color	Remarks
P1-A	P2-8	Green	TxD+/RxD+
P1-B	P2-9	Blue	+30V
P1-C	P2-8	Gray	+12V
P1-D	P1-A	Green	Jumper
P1-E	P2-4	Red	RxD1+
P1-F	P2-5	White	RsD-
P1-G	N.C.		
P1-H	P2-20	Pink	Gnd
P1-J	P2-7	Yellow	TxD-
P1-K	P2-3	Violet	TxD1-
P1-L	P2-2	Black	TxD1+
P1-M	P2-1	Orange	RxD1-

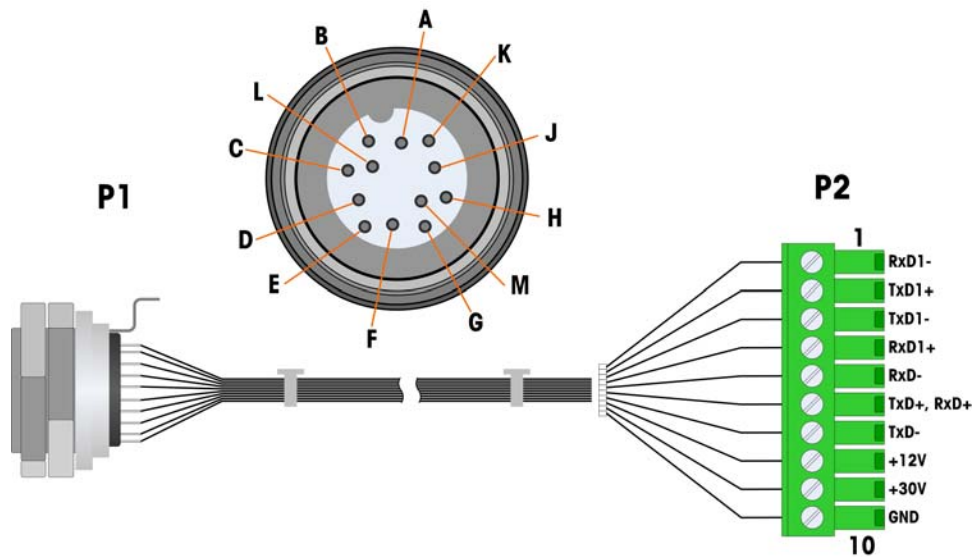

Figure 2-70: IDNet Cable for IDNet Option Board

Serial Option Board

Connections

The Serial option board provides an extra COM port. The card can be placed in slots 2 to 6 on the main PCB. The board is shown in Figure 2-71, and connector pin assignments in Figure 2-72.

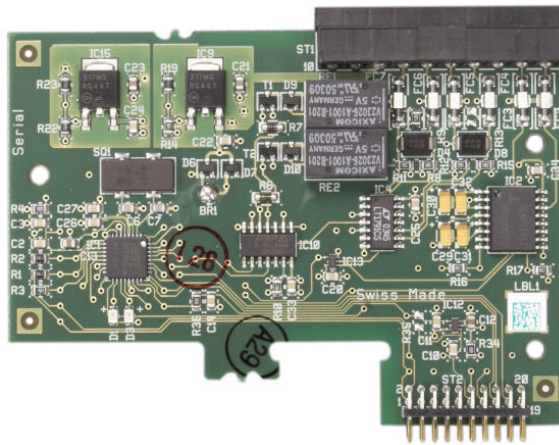

Figure 2-71: Serial Option Board

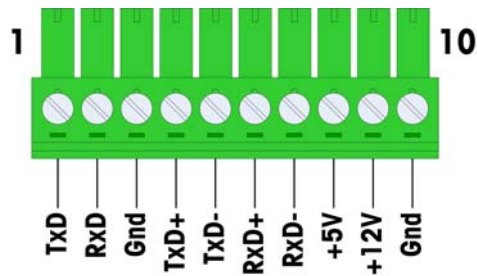

Figure 2-72: Serial Option Board Connector

Port connector assignments for this board are shown in Figure 2-73, and termination for RS232, RS422 and RS485 in Table 2-13.

Table 2-13: Serial Option Board Pin Connections

Pin	Signal	Function	Notes
1	TxD	RS-232 Transmit data	
2	RxD	RS-232 Receive data	
3	GND	RS-232 Signal ground	
4	TxD+	RS-422/485 Transmit +	Jumper to RxD+ for RS-485
5	TxD-	RS-422/485 Transmit -	Jumper to RxD- for RS-485
6	RxD+	RS-422/485 Receive +	Jumper to TxD+ for RS-485
7	RxD-	RS-422/485 Receive -	Jumper to TxD- for RS-485
8	+5V	+5V out, 0.5 A max.	
9	+12V	+12V out, 0.5 A max.	
10	GND	Ground	

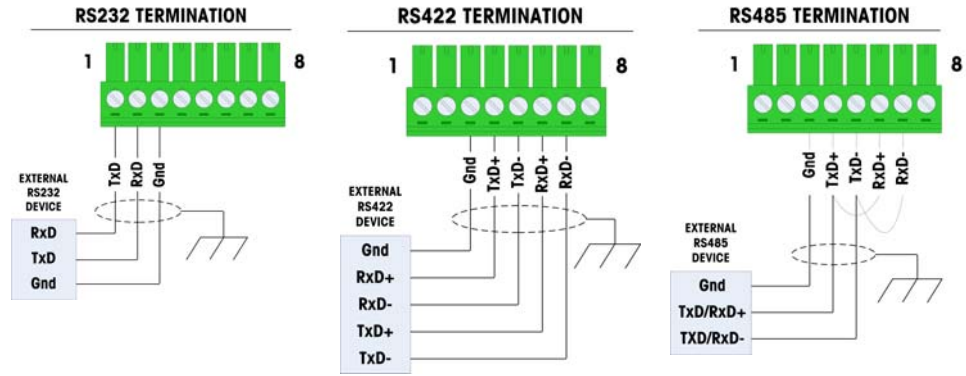

Figure 2-73: Connector Terminations for Serial Option Board

RS-485 Transmission Line Termination

The RS-485 network should include a terminating resistor, installed between the two lines at or on the last node. The terminating resistor should match the characteristic impedance of the transmission line, approximately 120 ohms. This terminating resistor is required when connecting ARM100 modules to the port.

PLC Interface Modules

DeviceNet Connections

The DeviceNet option board (Figure 2-74) is connected to the network by a DeviceNet-specific twisted pair cable.

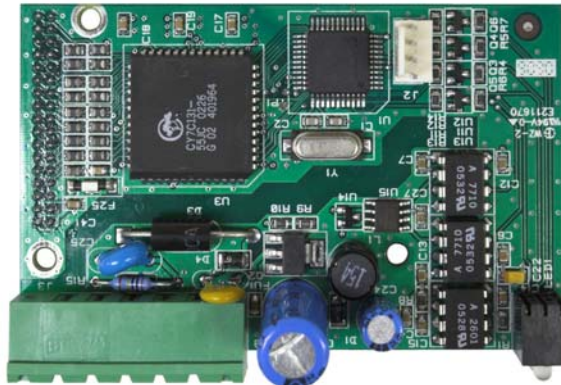
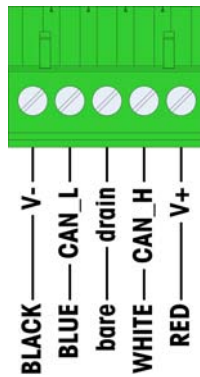

Figure 2-74: DeviceNet Option Board

Figure 2-75 indicates the pin numbering of the DeviceNet Option Board connector., Wire colors and functions are detailed in Figure 2-76.



Figure 2-75: DeviceNet Option Board Connector Pin Numbering



NOTES:

1. CONNECTION WITH 2 TWISTED PAIR SHIELDED CABLE BELDEN 3082A OR 2083A OR EQUIVALENT.
2. REFER TO O.D.V.A. DEVICENET DOCUMENTATION FOR OTHER CONSIDERATIONS.
3. WIRE SIZE: 14 AWG (2.088 mm2) MAXIMUM
22 AWG (0.322 mm2) MINIMUM.

Figure 2-76: DeviceNet Connector Wiring

Consult <http://www.odva.org/> for additional DeviceNet wiring information.

PROFIBUS Connections (Harsh Enclosure)

The PROFIBUS connection to the harsh enclosure is made using a straight nine pin connector inside the IND780 Q.iMPACT enclosure. Follow the instructions included with the connector to terminate the wires. Figure 2-77 shows the PROFIBUS module for use in the Harsh Enclosure, with its connector at upper right.

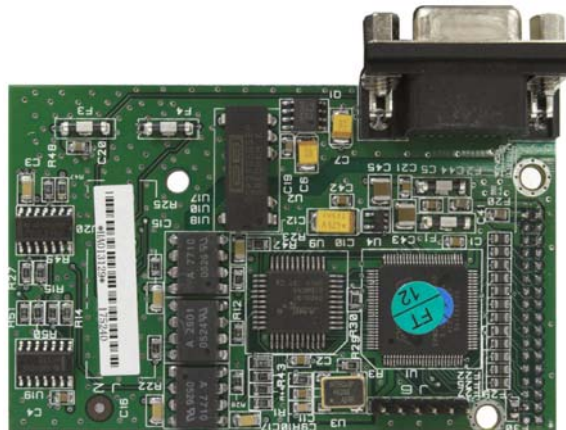

Figure 2-77: PROFIBUS PLC Module for Harsh Enclosure

Follow the wiring instructions included with the connector to terminate the wires.

PROFIBUS Connections (Panel Mount Enclosure)

The PROFIBUS connection to the Panel Mount enclosure is made using a straight nine-pin connector. The connector will extend through the cutout in the back panel of the terminal. This connector (or an equivalent) is a standard METTLER TOLEDO part # 64054361. The connector is not supplied by METTLER TOLEDO as part of the option.

Attach the nine-pin mating plug to the connector. Pin assignments are shown in Figure 2-78. Follow the wiring instructions included with the connector to terminate the wires.

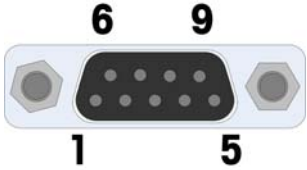

PROFIBUS CONNECTOR WIRING	
PIN	SIGNAL
1	None
2	None
3	RxD/TxD +
4	RTS
5	Gnd BUS
6	+5V BUS
7	None
8	RxD/TxD -
9	None

Figure 2-78: PROFIBUS 9-Pin Connector Assignments

Figure 2-79 shows the PROFIBUS board used in panel mount installations, with the appropriate connector circled.

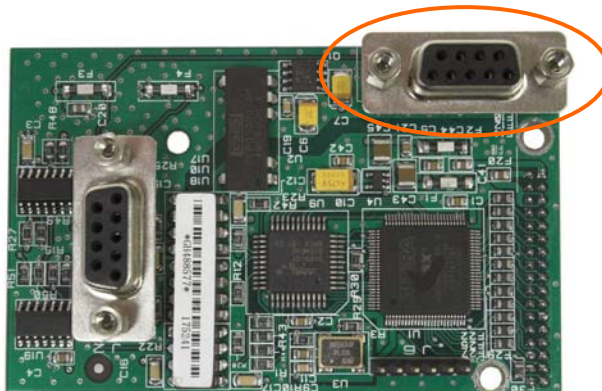

Figure 2-79: PROFIBUS PLC Module for Panel Mount Enclosure

Figure 2-80 shows (from left to right) the module installed in the panel mount enclosure, with the connector attached, and the rear panel in place.



Figure 2-80: PROFIBUS PLC Module Connector for Panel Mount Enclosure

ControlNet Interface

The ControlNet PLC Module (Figure 2-81, Figure 2-82) connects to the ControlNet network via one or two coaxial cables (Figure 2-84). Channel B is redundant with Channel A, and is not used unless ControlNet detects no signal on Channel A. Note that the module's address is set in software, and the MAC ID switches indicated in Figure 2-82 are not used.

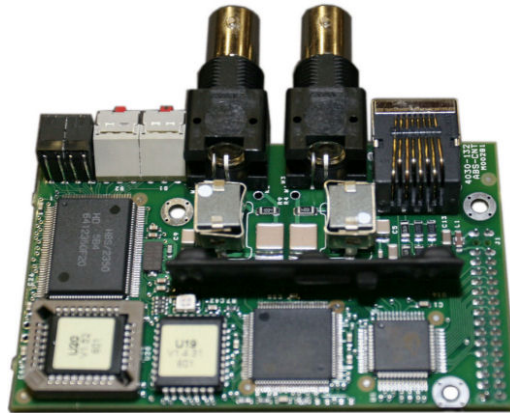

Figure 2-81: ControlNet PLC Module

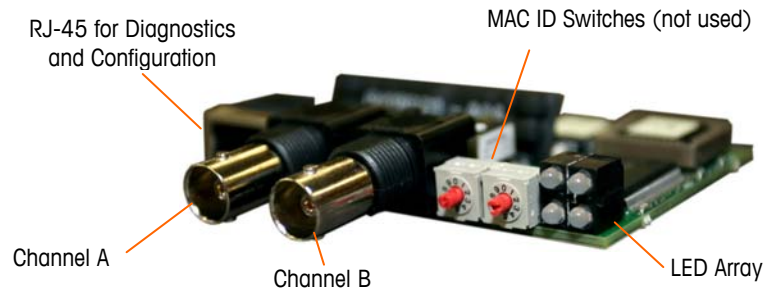

Figure 2-82: ControlNet PLC Module Connections and Components

- Do not plug an Ethernet cable into the RJ-45 connector shown at left in Figure 2-82. Damage to the IND780 Q.iMPACT may result.

Figure 2-83 shows the array of status indicator LEDs on the ControlNet card (see also Figure 2-82).

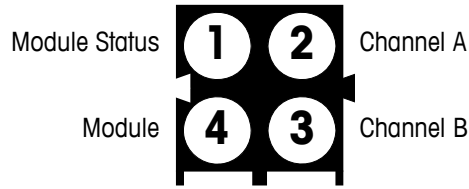

Figure 2-83: ControlNet Status Indicator LEDs

Figure 2-84 shows an example of a ControlNet cable, and a close-up view of the connector. Note that the connector may be straight or right-angled, as seen here. This cable is not supplied by Mettler Toledo.

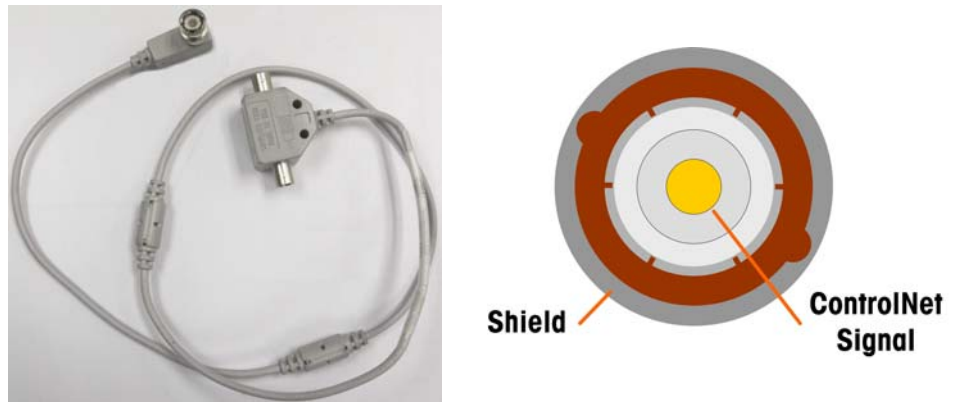

Figure 2-84: ControlNet Cable and Connector

Ethernet / IP and Modbus TCP Interface

The Ethernet / IP Module (Figure 2-85, Figure 2-86) connects to the network via a standard Ethernet patch cable. The module's address is set in software, and the DIP switches indicated in Figure 2-86 are not used and must all be set to OFF.

Note: For use in a Modbus TCP network, the module must be version 1.32 or higher.



Figure 2-85: Ethernet / IP PLC Module

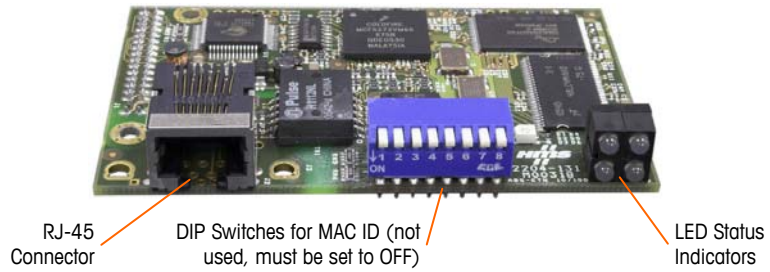

Figure 2-86: Ethernet / IP PLC Module Components

Figure 2-87 shows the array of status indicator LEDs on the Ethernet / IP card (see also Figure 2-86).

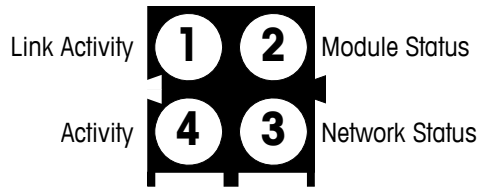

Figure 2-87: Ethernet / IP Status Indicator LEDs

Rockwell (Allen Bradley) RIO Connections

Connections to the Remote IO option are made using a three-pin terminal connector on the RIO option. The connection should be wired as shown in Figure 2-88.

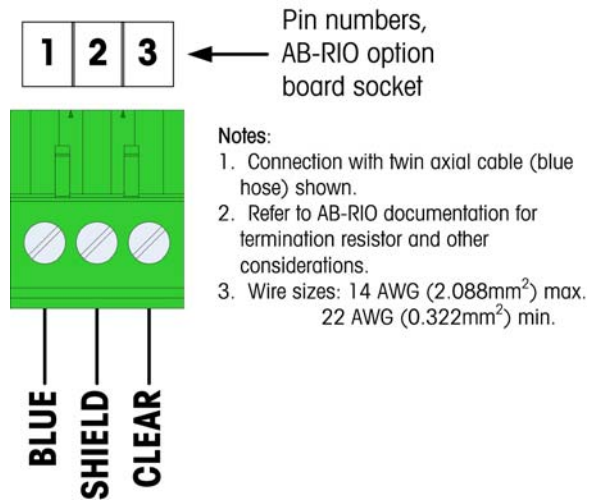

Figure 2-88: RIO Connection Wiring

The part number for the Remote IO cable is Belden 9463. It is sometimes referred to as "Blue Hose" cable.

Figure 2-89 shows the RIO PLC interface module, with its connector at upper right.

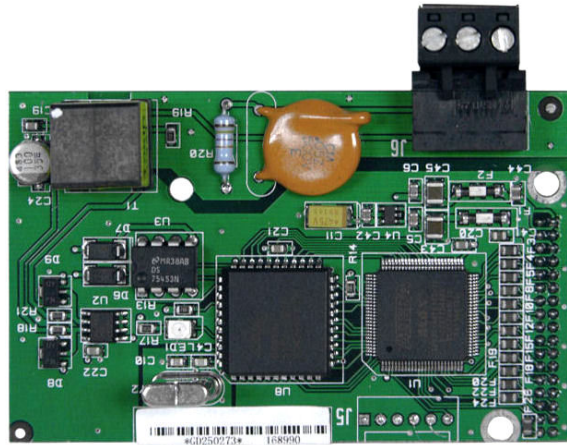

Figure 2-89: Allen Bradley RIO PLC Interface Module

Sealing the Enclosure

When the IND780 Q.iMPACT terminal is used in a metrologically “approved” application, it must be protected from tampering by use of seals. An optional sealing kit is available from METTLER TOLEDO that contains all the required hardware (Part number 64056538). Note that when the terminal is sealed non-metrological components cannot be serviced without breaking the seal.

Figure 2-90 and Figure 2-91 show the components of the sealing kit and how to use them, respectively.



Figure 2-90: Components of the Sealing Kit: Wire and Seal (left) and Screw (right)



Figure 2-91: Use of the Sealing Kit: Wire Through Screw (left), Wire Through Seal (center), Seal Closed (right)

Panel Enclosure Sealing

The Panel Mount enclosure must be sealed internally and externally. Follow these steps:

1. Ensure that the appropriate approval region has been selected in setup under Scale > Type > Approval and that the Metrology security switch S1 is in the "on" position.
2. Install the Security Cover to prevent access to S1, the Metrology Security Switch indicated in Figure 2-92, Main PCB Switches.

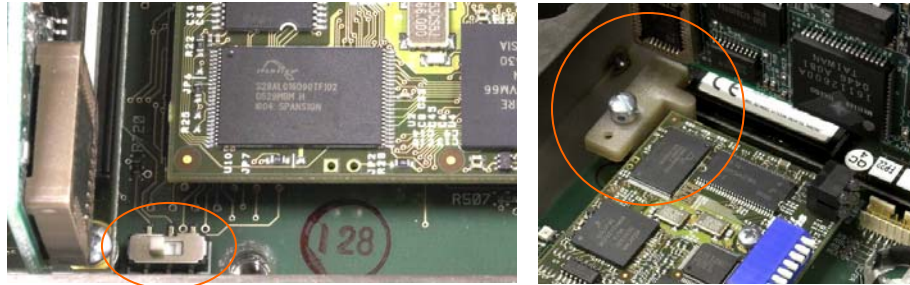

Figure 2-92: Metrology Security Switch (left) and Cover Installed (right)

3. To protect the load cell interconnecting cable/s (attached to option boards), a security seal must be placed over the connectors to ensure that they are not removed or disconnected. The seal also prevents access to the wire retaining screws indicated in Figure 2-93. Figure 2-94 shows a seal in place.

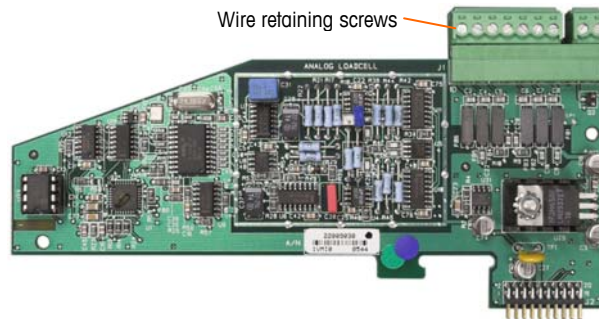

Figure 2-93: Unprotected Option Board Connection

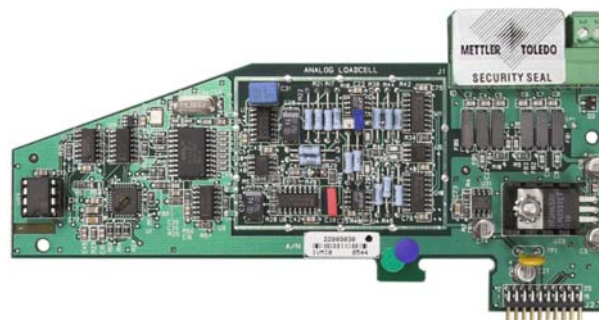

Figure 2-94: Security Seal Installed

4. Finally, the back panel of the enclosure is sealed. Three sealing screws are indicated in Figure 2-95 – two secure the panel in place on its stand-offs and one secures one end of the upper card guide.

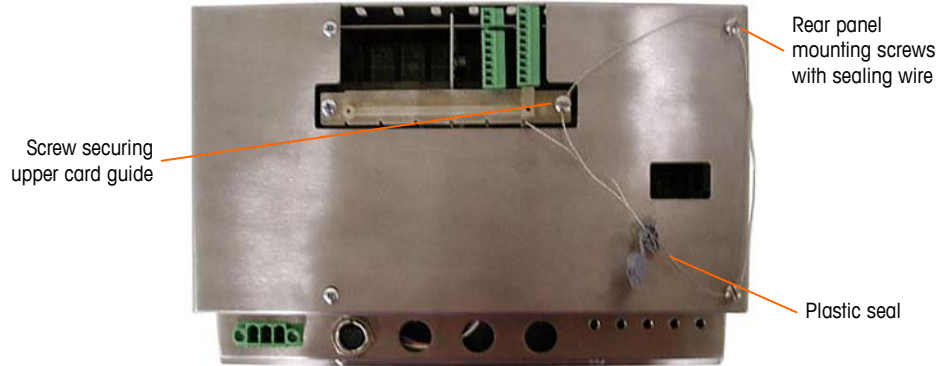

Figure 2-95: 3-Point Sealing, Panel Enclosure Rear Cover

5. With the screws installed, thread the sealing wire through each of them, then thread its ends through the plastic seal.
6. Remove most of the slack from the wire, and snap the seal shut.

Harsh Enclosure Sealing

For external sealing of the harsh enclosure, refer to Figure 2-90 and Figure 2-96 and follow these steps:

1. Ensure that the appropriate approval region has been selected in setup under Scale, Type, Approval and that the Metrology security switch SW1-1 is in the “on” position.
2. With the front panel installed on the enclosure and snapped into place, thread the free end of the wire seal through either the left or right hole in the IND780 Q.iMPACT terminal front panel, and through the hole in the retaining clip.
3. Thread the end of the wire cable through the hole in the plastic seal (as shown in Figure 2-96), remove any remaining slack in the wire, and snap the seal shut.



Figure 2-96: Harsh Enclosure Seal Threaded and Ready to be Closed – Standard Orientation (left) and with Panel Reversed (right)

4. Trim off any excess wire.

METTLER TOLEDO

1900 Polaris Parkway
Columbus, Ohio 43240

METTLER TOLEDO[®] is a registered
trademark of Mettler-Toledo, Inc.

©2009 Mettler-Toledo, Inc.



64068656