

Excellence Comparators Balances

XP56/26/205CDR/505 Models – Part 1



METTLER TOLEDO

Table of Contents

1	Introduction		5
	1.1	Conventions and Symbols Used in These Operating Instructions	6
2	Safety Information		7
	2.1	Definition of Signal Warnings and Symbols	7
	2.2	Product Specific Safety Notes	7
3	Overview XP Comparator Balances		9
	3.1	Overview XP56/XP26 Balances	9
	3.2	Overview XP205CDR/XP505 Balances	10
4	Setting up the Balance		11
	4.1	Unpacking and Checking the Delivered Items	11
	4.1.1	Unpacking the Balance	11
	4.2	Scope of Delivery	13
	4.3	Selecting a Location	14
	4.4	Assembling the Balance	15
	4.4.1	Inner Draft Shield XP56/XP26 Comparator Balances	15
	4.4.2	Outer Draft Shield XP56/XP26/XP205CDR/XP505	17
	4.5	Power Supply	19
	4.6	Operating of the Outer Draft Shield and the Inner Draft Shield	20
	4.6.1	Outer Draft Shield	20
	4.6.2	Inner Draft Shield XP56/XP26	21
	4.7	Setting the Reading Angle and Positioning the Terminal	21
	4.7.1	Setting the Reading Angle	21
	4.7.2	Remove Terminal and Place Close to the Balance	21
	4.8	Transporting the Balance	22
	4.8.1	Transporting Over Short Distances	22
	4.8.2	Transporting Over Long Distances	23
	4.9	Installing the ErgoClip	26
	4.10	Installing the Grid Weighing Pan Cover	26
5	First Steps		28
	5.1	Switching On / Off	28
	5.2	Leveling the Balance	28
6	Special Settings for XP56/XP26/XP205CDR/XP505 Comparator Balances		30
	6.1	Load the Balance	30
	6.2	Settings for the Outer and Inner Draft Shield	30
	6.3	Settings for the Comparators	31
	6.3.1	Settings of the Standard Types XP56/XP26/XP205CDR/XP505 Comparator Balances	31
	6.3.2	Settings of the Certified Version XP56/A, XP56/M, XP26/A, XP26/M Comparator Balances	32
7	Maintenance		33
	7.1	Cleaning	33
	7.2	Disposal	33

8	Technical Data		34
	8.1	General Data	34
	8.2	Explanatory Notes for the METTLER TOLEDO AC Adapter	34
	8.3	Model-specific Data	35
	8.4	Dimensions	38
	8.4.1	Dimensions of the XP56/XP26 Comparators	38
	8.4.2	Dimensions of the XP205CDR/XP505 Comparators	40
	8.5	Interfaces	41
	8.5.1	Specifications of RS232C	41
	8.5.2	Specifications of "Aux" Connection	41
9	Accessories and Spare Parts		42
	9.1	Accessories	42
	9.2	Spare Parts	50
10	Appendix		52
	10.1	MT-SICS Interface Commands and Functions	52
	10.2	Procedure for Certified Balances	52
11	Index		54

1 Introduction

Thank you for choosing a METTLER TOLEDO balance.

The balances of the XP line combine a large number of weighing and adjustment possibilities with exceptionally convenient operation.

In this chapter you will be given basic information about your balance. Please read right through this chapter carefully even if you already have experience with METTLER TOLEDO balances. Please pay special attention to the safety warnings!

The different models have different characteristics regarding equipment and performance. Special notes in the text indicate where this makes a difference to operation.

The XP line comprises a range of balances which differ from each other in relation to their weighing range and resolution.

The following features are common to all models of the XP lines:

- Glass draft shield with motorized drive and inner glass draft shield for precise weighing even in unstable environments.
- Fully automatic adjustment "ProFACT" using internal weights.
- Built-in level sensor, illuminated level indicator and Leveling Assistant for fast and easy leveling.
- Built-in applications for WeighCom, normal weighing, statistics, formulation, piece counting, percent weighing, density, differential weighing, and LabX Client.
- Integral RS232C interface.
- Slot for second interface (optional).
- Touch-sensitive graphics terminal ("Touch Screen") with color display.
- Two programmable sensors for hands-off operation ("SmartSens") to speed up frequently recurring tasks.

A brief word about standards, guidelines, and methods of quality assurance: The balances comply with usual standards and guidelines. They support standard procedures, specifications, working methods, and reports according to **GLP (Good Laboratory Practice)**. In this connection, records of working procedures and adjustments become very important; for this purpose we recommend you to use a printer from the METTLER TOLEDO range, since these are optimally adapted to your balance. The balances conform to the applicable standards and guidelines and possess a EC declaration of conformity. METTLER TOLEDO is certified as manufacturer according to ISO 9001 and ISO 14001.

The Operating Instructions for the XP balances consist of 4 separate documents, whose contents are listed below.

Part 1, This Document

Contents

- Introduction
- Safety Information
- Setting up the Balance
- Leveling the Balance
- Settings for XP56/XP26/XP205CDR/XP505 Comparator Balances
- Cleaning and Service
- Technical Data
- Interface commands and MT-SICS functions
- Accessories
- Spare Parts

Part 2, Separate Document

Contents: Terminal, System and Applications

- Basic Principles for Using the Terminal and the Firmware
- System Settings
- User-specific Settings
- Applications
- Firmware (Software) Updates
- Error and Status Messages
- Conversion Table for Weight Units
- Recommended Printer Settings

Part 3, Separate Document

Contents: Adjustments and Tests

- Adjustments
- Tests

Operating Instructions "WeighCom Application for XP Comparator Balances"

When working with the WeighCom application, use the operating instructions "WeighCom Application for XP Comparator Balances" that were included with the delivery.

Finding More Information

Internet <http://www.mt.com/excellence>

1.1 Conventions and Symbols Used in These Operating Instructions

The following conventions apply to the operating instructions: Part 1, Part 2, Part 3 and WeighCom Application for XP Comparator Balances.

Key and button designations are indicated by a picture or text in square brackets (e.g.  or [On/Off]).



This symbol indicates press key briefly (less than 1.5 s).



This symbol indicates press and hold key down (longer than 1.5 s).

These symbols indicate an instruction:

- ▶ prerequisites
- 1 steps
- 2 ...
- ⇒ results

2 Safety Information

2.1 Definition of Signal Warnings and Symbols

Safety notes are indicated by signal words and warning symbols and contain warnings and information about safety issues. Ignoring safety notes can lead to personal injury, damage to the instrument, malfunctions and erroneous results.

Signal Words

WARNING	for a hazardous situation with medium risk, possibly resulting in severe injuries or death if not avoided.
CAUTION	for a hazardous situation with low risk, resulting in damaged to the device or the property or in losing of data or minor or medium injuries if not avoided.
Attention	(no symbol) for important information about the product.
Note	(no symbol) for useful information about the product.

Warning Symbols



General hazard



Electrical shock

2.2 Product Specific Safety Notes

Always operate and use your balance only in accordance with the Operating Instructions Part 1, Part 2, Part 3 and WeighCom Application for XP Comparator Balances.

The instructions for setting up your new balance must be strictly observed.

If the instrument is not used according to the manufacturer's Operating Instructions (Part 1, Part 2, Part 3 and WeighCom Application for XP Comparator Balances), protection of the instrument may be impaired.

Intended Use

Your balance is used for weighing. Use the balance exclusively for this purpose. Any other type of use and operation beyond the limits of technical specifications without written consent from Mettler-Toledo AG, is considered as not intended.



It is not permitted to use the instrument in explosive atmosphere of gases, steam, fog, dust and flammable dust (hazardous environments).

**CAUTION****Damage of Device**

- For use only in dry interior rooms.
 - Do not use sharply pointed objects to operate the keyboard! Although your balance is very ruggedly constructed, it is nevertheless a precision instrument. Treat it with corresponding care.
 - Do not open the balance: It does not contain any parts which can be maintained, repaired, or replaced by the user. If you ever have problems with your balance, contact your METTLER TOLEDO dealer.
 - Use only balance accessories and peripheral devices from METTLER TOLEDO; they are optimally adapted to your balance.
-

**CAUTION****Damage of Device**

Use only the original universal AC adapter delivered with your balance, and check that the voltage printed on it is the same as your local power supply voltage. Only plug the adapter into a socket which is grounded.

3 Overview XP Comparator Balances

3.1 Overview XP56/XP26 Balances

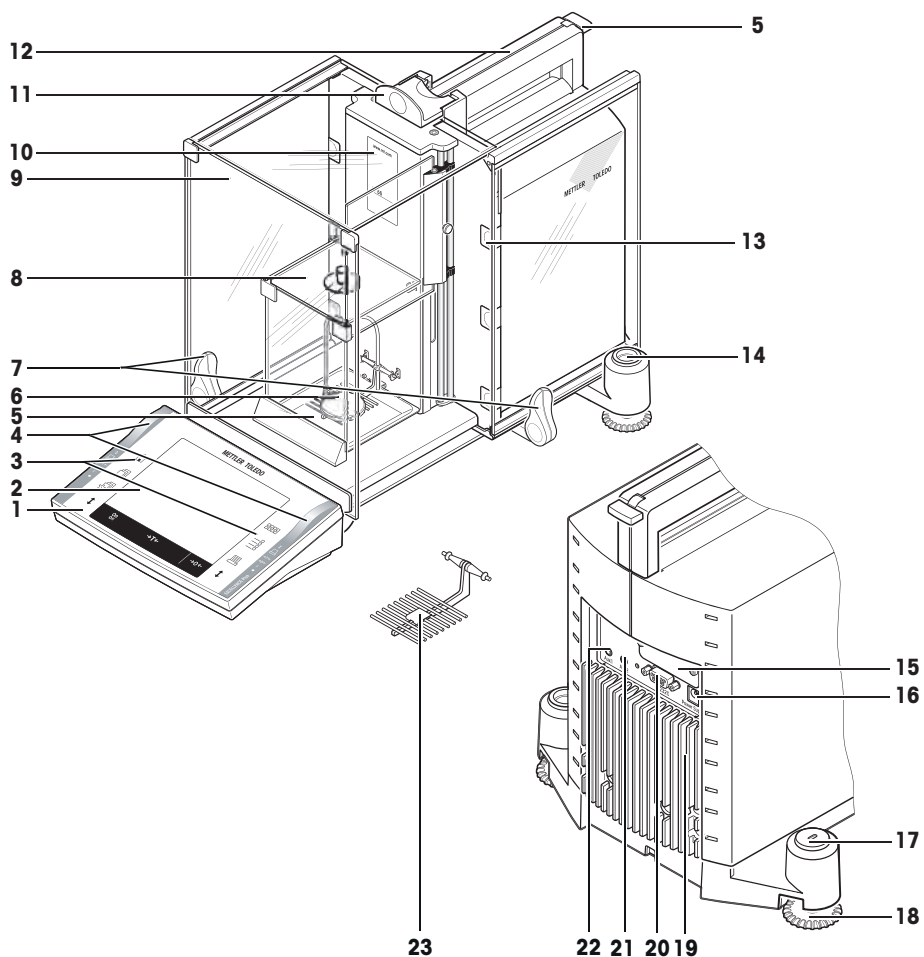

Overview XP56/XP26

1	Terminal (details see Operating Instructions – Part 2)	2	Display (Touch-sensitive "Touch Screen")
3	Operating keys	4	SmartSens sensors
5	Drip tray	6	Hanging weighing pan
7	Handle/Coupling element for the operation of the outer draft-shield doors	8	Inner glass draft shield
9	Outer glass draft shield	10	Type name
11	Handle for operation of the outer draft-shield top door	12	Guide for top door of draft shield and handle for transport
13	Removable clips for feeding cables or hoses	14	Level indicator / Level sensor
15	Slot for second interface (optional)	16	Socket for AC adapter
17	Fastening point for anti-theft device	18	Foot screw
19	Cooling element (based on model)	20	RS232C serial interface
21	Aux 2 (connection for "ErgoSens", hand- or foot-switch)	22	Aux 1 (connection for "ErgoSens", hand- or foot-switch)
23	Grid weighing pan		

3.2 Overview XP205CDR/XP505 Balances

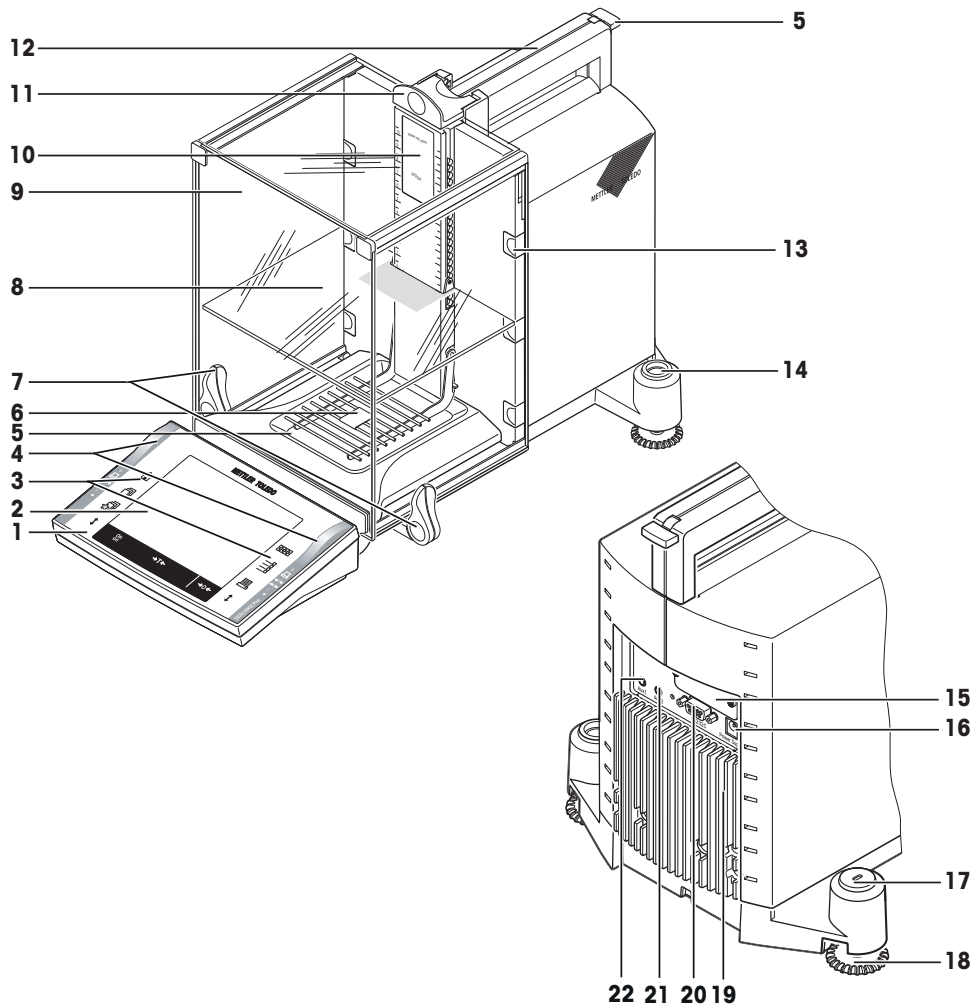

Overview XP205DR/XP505

1	Terminal (details see Operating Instructions – Part 2)	2	Display (Touch-sensitive "Touch Screen")
3	Operating keys	4	SmartSens sensors
5	Drip tray	6	Grid weighing pan
7	Handle/Coupling element for the operation of the outer draft-shield doors	8	Intermediate shelf
9	Glass draft shield	10	Type name
11	Handle for operation of the outer draft-shield top door	12	Guide for top door of draft shield and handle for transport
13	Removable clips for feeding cables or hoses	14	Level indicator / Level sensor
15	Slot for second interface (optional)	16	Socket for AC adapter
17	Fastening point for anti-theft device	18	Foot screw
19	Cooling element (based on model)	20	RS232C serial interface
21	Aux 2 (connection for "ErgoSens", hand- or foot-switch)	22	Aux 1 (connection for "ErgoSens", hand- or foot-switch)

4 Setting up the Balance

This chapter explains how to unpack your new balance, and how to set it up and prepare it for operation. When you have carried out the steps described in this chapter, your balance is ready for operation.

4.1 Unpacking and Checking the Delivered Items

4.1.1 Unpacking the Balance

- 1 Lift the cardboard box (1) out of the packaging.
- 2 Take out the Operating Instructions that explain the further procedure for unpacking and assembling your balance.

Overview

- 1 Cardboard box with 2 sets (see next 2 pictures)
- 2 Top packing cushion
- 3 Set with inner draft shield, drip tray, and grid weighing pan micro
- 4 Balance
- 5 Lifting strap
- 6 Terminal

Note

The terminal is connected to the balance by a cable!

- 7 Bottom packing cushion

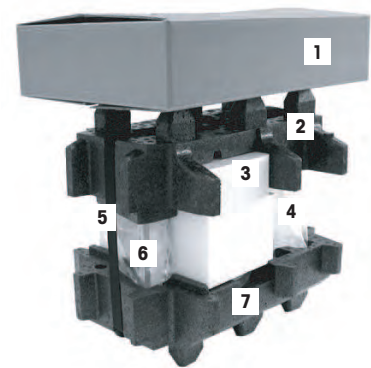

- Take the Operating Instructions and other documents (8) out of the cardboard box.



- 1 Pull out set (9) with AC adapter, power supply cable, tweezers, and the set containing hanging weighing pan, ErgoClip basket micro and grid weighing pan cover micro.
- 2 Pull out set (10) with outer draft shield doors and terminal support.



Set with:

- ErgoClip basket micro
 - Hanging weighing pan and support (11)
 - Support (12)
 - Basket (13)
- Grid weighing pan cover micro (14).

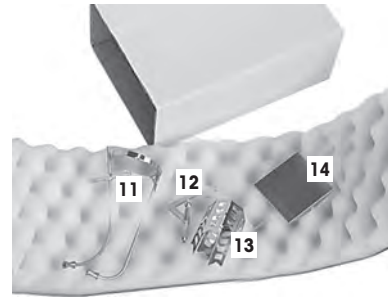

Use the lifting strap to lift the balance out of the packaging carton.

- 1 Unfasten lifting strap (5).
- 2 Remove top packing cushion (2).

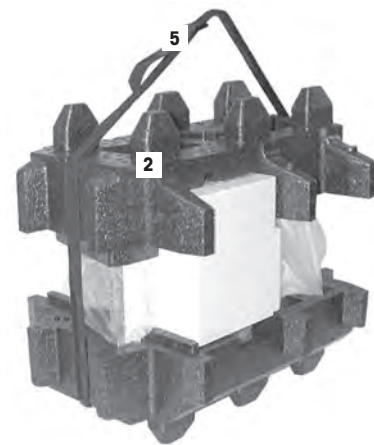

- Pull out set (3) with inner draft shield etc.



- Carefully pull the terminal out of the bottom packing cushion and remove the protective cover.

Note

The terminal is connected to the balance by a cable, so only pull the terminal just far enough out of the packing cushion to remove the protective cover.



- 1 Place the terminal on the front of the balance.
- 2 Hold the balance by the guide or handle, hold the terminal firmly with your other hand, and pull the balance and terminal together out of the bottom packing cushion.



- 1 Place the balance with the terminal in the place where the balance will be used for weighing.
- 2 Remove the cover from the balance.



Note

Please keep all parts of the packaging. This packaging guarantees best possible protection of your balance for transportation, **see** Transporting the Balance (page 22)

4.2 Scope of Delivery

The standard scope of delivery contains the following items:

- Balance with terminal
 - RS232C interface
 - Slot for second interface (optional)
 - Feedthroughs for below-the-balance weighing and for antitheft device

- Set with inner & outer draft shield, drip tray, hanging weighing pan and terminal support for XP26 and XP56 comparator
 - Ergo Clip basket micro with support
 - Grid weighing pan cover micro (attachment for grid weighing pan)
- Set with outer draft shield, drip tray and grid weighing pan micro for XP205CDR and XP505 comparator
- Protective cover for the terminal
- AC adapter with country-specific power cable
- Tweezers
- Cleaning brush
- Production certificate
- CE declaration of conformity
- Operating Instructions Part 1 (this document), Part 2, Part 3 and WeighCom Application for XP Comparator Balances

4.3 Selecting a Location

Choose a position which is stable, free from vibration, and as nearly horizontal as possible. The supporting surface must be able to bear the weight of the fully loaded balance safely.

Avoid the following:

- Direct sunlight
- Draft (e.g. from fans or air conditioning)
- Excessive fluctuations in temperature.

Further information can be found in Weighing the Right Way.

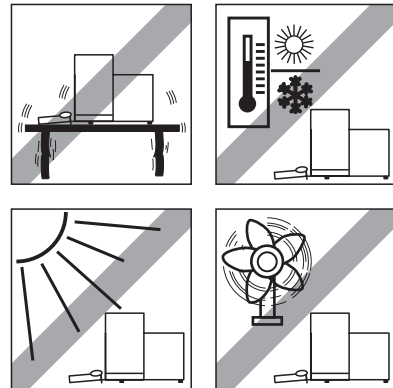

Observe ambient conditions. **See** Technical Data (page 34).

Note

If the balance is not horizontal from the beginning, it will have to be leveled during initial operation. **See** Leveling the Balance (page 28).

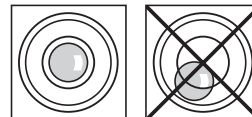

4.4 Assembling the Balance

4.4.1 Inner Draft Shield XP56/XP26 Comparator Balances

- 1 Insert the front glass (1) of the inner draft shield.
- 2 Ensure the glass is centered and pushed in as far as the stop.

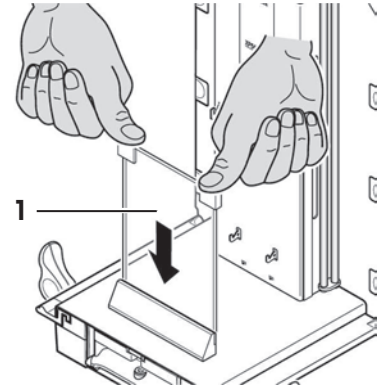

Hanging weighing pan



CAUTION

Damage of Device

When installing the hanging weighing pan, it is advisable to wear gloves.

- 1 Insert the drip tray (1).
- 2 Insert the support (2).
- 3 Check that the guide is correctly installed on both sides.
- 4 Place the hanging weighing pan (3) on the swivel bearing by the support (2).

Attention

- 5 After you have installed the hanging weighing pan (balance in operation) you must switch the balance off and then switch it on again «On/Off» key.

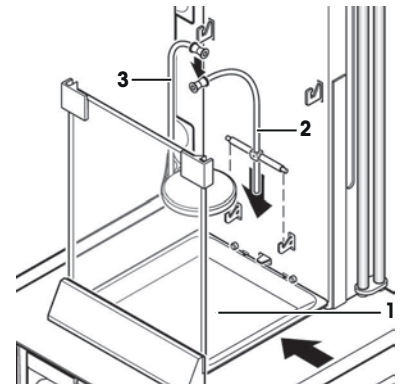

Grid weighing pan

- 1 Insert the drip tray (1).
- 2 Insert the drip tray from the side under the upper 2 pins. The notches must be positioned by the springs.
- 3 Insert the grid weighing pan (2) from above.
- 4 Check that the grid weighing pan is correctly hooked in on both sides.

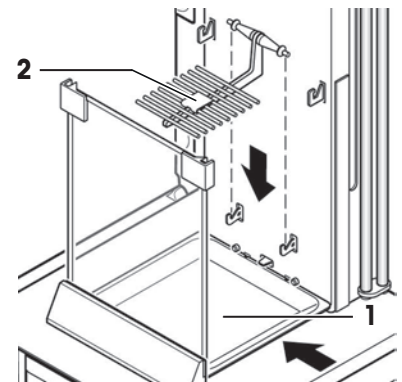

- 1 Insert the side window (1) of the inner draft shield.
- 2 At an angle of approximately 45 degrees to the final position, place the 2 black clips on the back guide shaft.
- 3 Push the window up until you can swivel it in over the front glass.

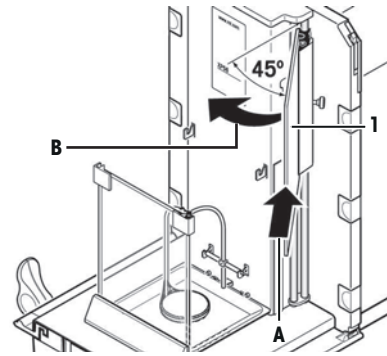

- 1 Insert the window (1) of the inner draft shield into the guide of the front glass and lower it to the floor.
- 2 The window must run easily.
- 3 Press the coupling pins (2) toward the inside.
- 4 Now insert the window on the other side of the inner draft shield. The procedure is the same.

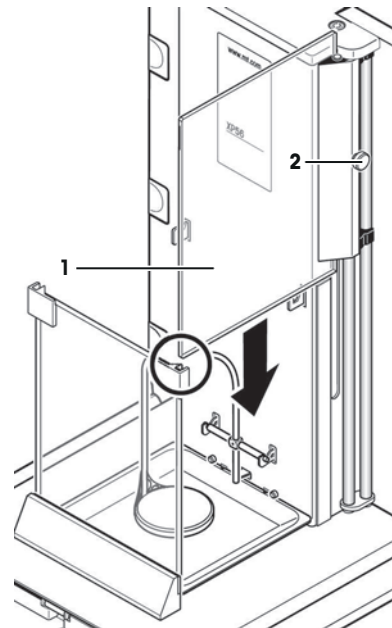

- 1 Put the top glass (1) on.
- 2 Insert the sealing cover (2).

Note

The sealing cover closes the opening in the top glass through which you can pipette into a high container.

Attention

Do not use the sealing cover to lift the top glass of the draft shield!

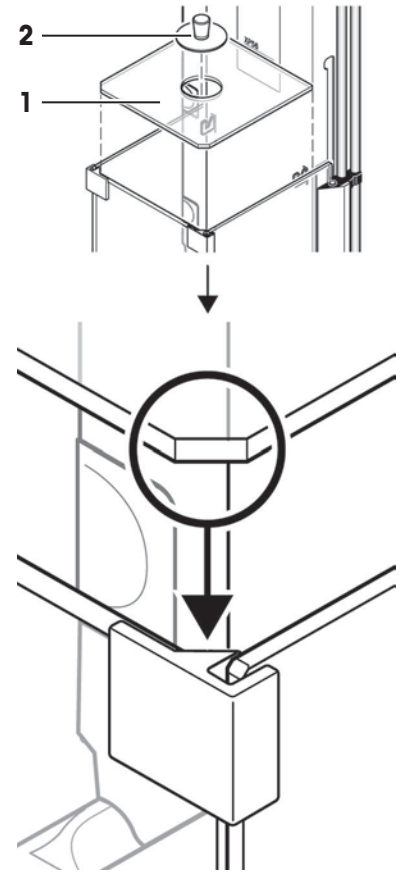

4.4.2 Outer Draft Shield XP56/XP26/XP205CDR/XP505

- 1 Insert the top door of the draft shield (1) at an angle (slightly less than 30 degrees) into the guide positioned at the **back**.
- 2 Swivel the draft-shield door (2) carefully down, **see** figure.

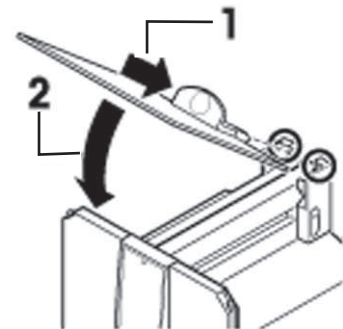

- ▶ The handles (A) must be turned toward the outside to allow installation of the side draft shield doors!
- 1 Insert the side doors of the draft shield according to the following instructions, **see** figure below.
 - 2 Insert the side door at an angle of approx. 30° into the 2 openings, **see** figure.
 - 3 Check that the side door is correctly inserted as shown!
 - 4 Swivel the side door up against the balance until it engages with a click.
 - 5 The side door must run easily, otherwise it is not correctly inserted.
 - 6 Insert the second side door of the draft shield.
⇒ The procedure is identical.
 - 7 Push the side doors completely to the back.

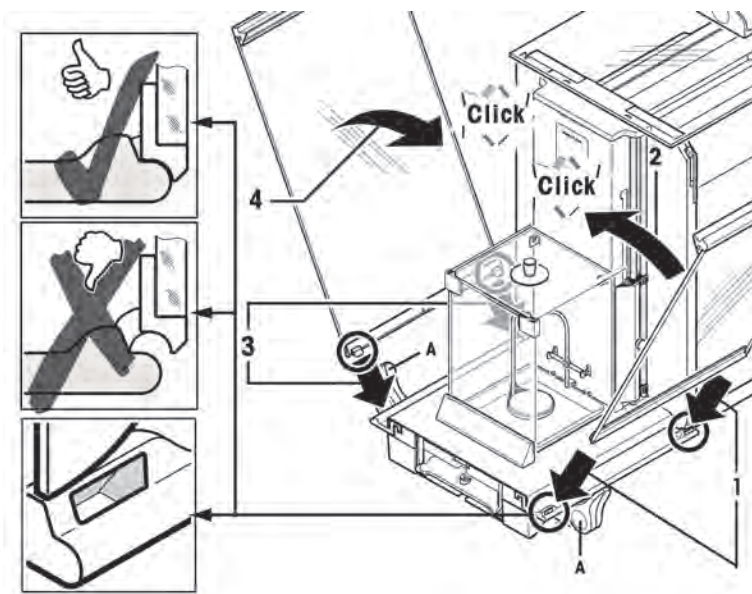

- 1 Insert the front glass (2) of the draft shield.
- 2 In the bottom part of the balance at the front, move at an angle from the top toward the bottom until the two hooks of the front glass of the draft shield lie on the rollers (1).
- 3 Swivel the front glass of the draft shield up until it engages.

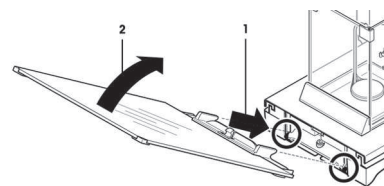

- 1 Insert the terminal support.
- 2 First lay the cable in the guide by the terminal support.
- 3 Insert the terminal support into the opening of the front glass of the draft shield.
⇒ The terminal support must engage with a click.

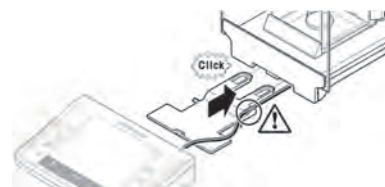

- 1 Mount the terminal.
 - 2 Place the terminal in the center of the support.
 - 3 Push it against the balance until it swivels slightly down at the front by the terminal support.
- ⇒ You can push the cable into the balance.

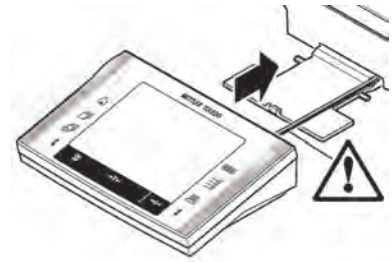

Attention

The balance and the terminal are not fastened together by the terminal support! When transporting by hand, always hold the balance and the terminal firmly, **see** Transporting the Balance (page 22).

Note

You can also place the terminal free of the terminal support anywhere around the balance where the length of the cable allows.

4.5 Power Supply



WARNING

Risk of electric shock

- Ensure that the AC power pack for the balance is only used in accordance with the specifications listed in chapter General Data.
- Your instrument is supplied with a 3-pin power cable with an equipment grounding conductor. Only extension cables which meet this relevant standards and also have an equipment grounding conductor may be used. Intentional disconnection of the equipment grounding conductor is prohibited.

- Your balance is delivered complete with an AC adapter and a country-specific power supply cable. The AC adapter is suitable for all power supply voltages in the range of: 100 – 240 VAC, 50/60 Hz, for exact specifications, **see** Technical Data (page 34).
- First, check whether the voltage of the power supply matches your local line voltage. If this is not the case, on no account connect the balance to the power, but contact your METTLER TOLEDO sales representative or dealer.
- Guide the cables so that they cannot become damaged and will not be in your way during your daily work! Take care that the AC adapter cannot come into contact with liquids!
- The power plug must be always accessible.
- Before operating, check all cables for damage.

- Plug the AC adapter (1) into the socket (2) in the back of your balance and into the power supply.
- ⇒ After the balance has been connected to the power supply, it carries out a self test and is then ready for operation.

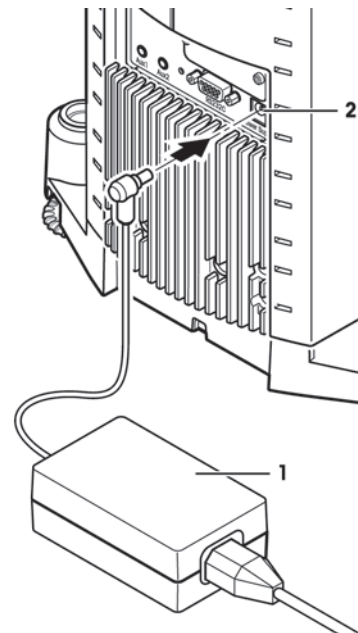

Note

If the display field remains dark, even though the power supply connection functions.

- 1 First disconnect the balance from the power supply.
- 2 Open the terminal.
- 3 Press both buttons (3) on the back of the terminal and open the upper part of the terminal.
- 4 Check that the plug for the terminal cable (4) is connected correctly inside the terminal.

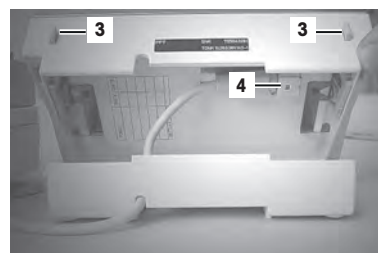

4.6 Operating of the Outer Draft Shield and the Inner Draft Shield

4.6.1 Outer Draft Shield

The outer draft shield of your balance can be adapted to the environmental conditions and your weighing style, as well as to the type of weighing and loading.

The doors of the outer draft shield can be opened and closed either by means of the «↑↓» key, the "SmartSens" sensors, or by hand, **see** Operating Instructions – Part 2.

Try various different combinations by moving the 3 external handles up/inside and down/outside. We recommend you to set up the outer draft shield so that it only opens on the side where the balance is loaded. Your balance then works faster, because there are fewer troublesome currents of air than when both doors of the outer draft shield are opened together.

- 1 For **motorized door operation** the handles must be connected.
 - ⇒ Side doors: Handles turned toward the inside.
 - ⇒ Top door: Handle down in horizontal position.
- 2 For **manual door operation** the handles must be disconnected.
 - ⇒ Side doors: Handles turned toward the outside.
 - ⇒ Top door: Handle up in vertical position.

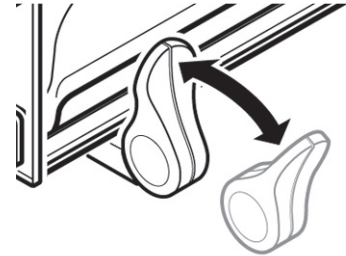
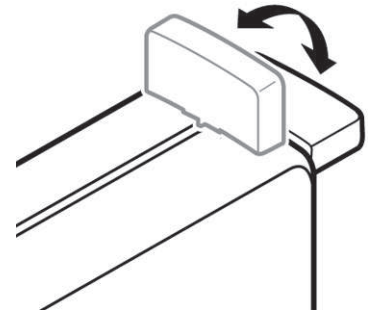

Note

It is best to make connections when the draft shield is closed.

4.6.2 Inner Draft Shield XP56/XP26

- For **motorized operation** of the inner draft shield the coupling bolts (1) must be pressed **inward**.
 - ⇒ The two side doors can be controlled separately.

You can also open the side doors of the inner draft shield only part-way, with a choice of 25 %, 50 % or 75 %, **see** Operating Instructions – Part 2.

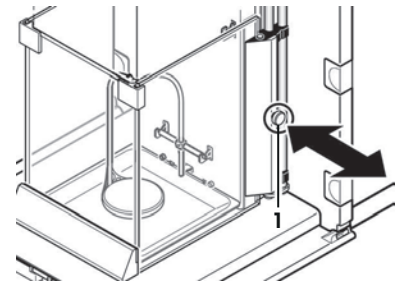

4.7 Setting the Reading Angle and Positioning the Terminal

4.7.1 Setting the Reading Angle

- 1 Press in the two buttons (1) on the back of the terminal.
 - ⇒ The top of the terminal can then be pulled up or pushed down until it engages in the desired position. A total of 3 setting positions are available.
- 2 Move it in an appropriate position.

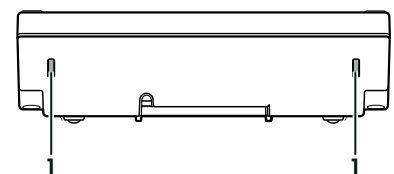

4.7.2 Remove Terminal and Place Close to the Balance

The terminal is connected to the balance by a cable. So you can arrange your workplace optimally, the terminal can be removed from the balance and placed separately.

Place the terminal separately

- 1 Switch the balance off.
- 2 Carefully lift the terminal off the terminal support.
You can leave the terminal support on the balance or remove it.
- 3 Pull the cable carefully out from the balance as far as possible.
- 4 Place the terminal where you want it to be.

Note

The cable can also be led out of the back of the balance. If working this way would be convenient for you, call your METTLER TOLEDO dealer who will adapt the balance for you.

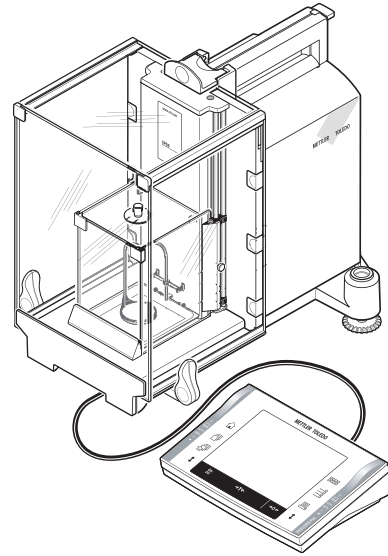

4.8 Transporting the Balance

- 1 Switch off the balance.
- 2 The balance must be disconnected from the power supply.
- 3 Remove any interface cable from the balance.

4.8.1 Transporting Over Short Distances

If you wish to move your balance over a short distance to a new location, proceed as follows.



CAUTION

Damage of Device

Never lift the balance by the glass draft shield or the cooling element, as this can cause damage!

- 1 With one hand, hold the balance by the guide for the top door of the draft shield.
- 2 With your other hand, hold the terminal. The terminal is not rigidly fastened to the balance, so you must always hold the balance with one hand and the terminal with the other.
- 3 Carefully lift the balance and carry it to its new location, observe the notes in chapter Selecting a Location (page 14).

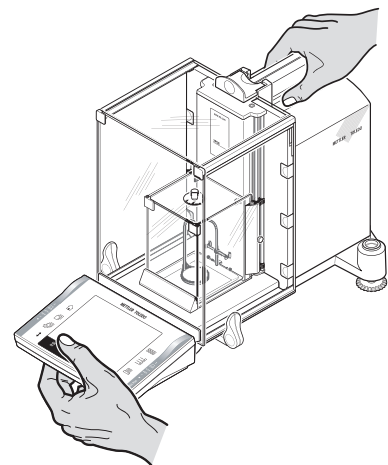

4.8.2 Transporting Over Long Distances

If you want to transport or ship your balance over long distances, or if it is not certain that the balance will be transported upright, use the complete original packaging.

Disassemble the following parts

- 1 Lift the terminal (1) out of the terminal support and place it next to the support.
- 2 Pull the terminal support (2) off the balance.
- 3 Swivel the front glass (3) of the outer draft shield away from the balance.
- 4 Carefully fold the side doors (4+5) against the respective handles and pull the side doors out of the guide.
- 5 Swivel the front of the top door (6) of the outer draft shield up and pull the door out of the guide.
- 6 Remove the sealing cover (7).
- 7 Lift the top glass (8) of the inner draft shield off.
- 8 Pull both side doors (9 + 10) off. Pull up, turn to the side, and pull away.
- 9 Lift the grid weighing pan (11) and lift it out of the guides.
- 10 Pull the drip tray (12) out at the side.
- 11 Pull the front glass (13) up and away.

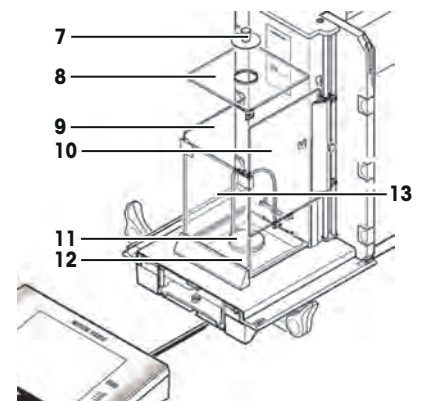
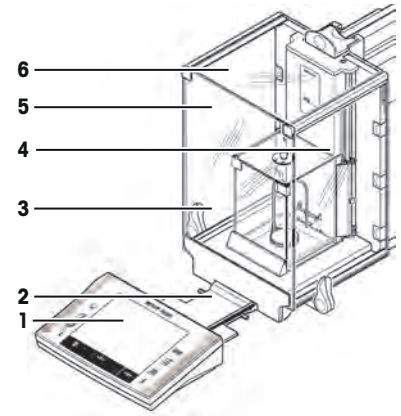

Pack the outer draft shield and the terminal support (Pos. 3-6 and 2)

- Place these parts in the compartments provided in the original packaging.

Note

We advise you to place a sheet of paper between the sides glasses of the draft shield.

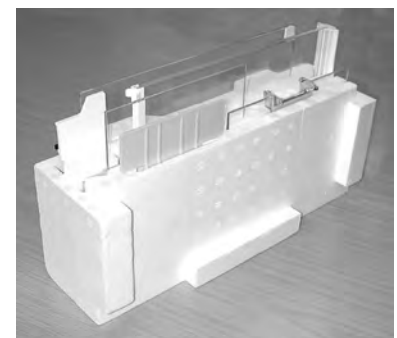

Pack the inner draft shield, the drip tray, and the grid weighing pan (Pos. 7-13)

- Place these parts in the special compartments provided in the original packaging.



Pack the set with

- Hanging weighing pan and support (1)
- ErgoClip basket micro
 - Support (2)
 - Basket (3)
- Grid weighing pan cover micro (4).

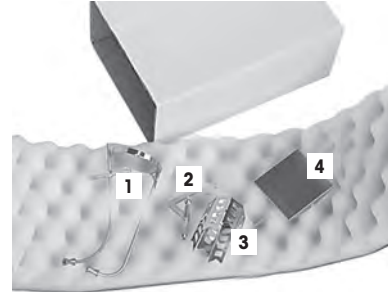

Pack the 2 sets (1 + 2)

- Set (1) with AC adapter, power cable, tweezers, and the set with the ErgoClip Basket micro and grid weighing pan cover micro.
- Set (2) with the outer draft shield and terminal support.
- The Operating Instructions and other documents.



CAUTION

Damage of Device

These instructions must be followed exactly, otherwise the balance may be damaged when inserting it into the packing cushions.

- 1 Push the guide of the upper draft shield door right to the front.
- 2 Push the guide of the draft shield side doors right to the front.
- 3 Fold the handles of the guides up/in.



Note

For packing both the balance and the terminal, you have a protective cover in which they were delivered. These are deliberately not shown in the illustrations so you can see better how the individual items must be positioned. However, we recommend you to use these protective covers.

- 1 Place the terminal on the balance (see illustration) and carefully insert the balance into the bottom packing cushion.
- 2 Take the terminal and place it in front of the packing cushion on the table.



- Place the set in the packing cushion along with the inner draft shield, **see** illustration.



- Insert the terminal into the packing cushion as shown in the illustration.



- 1 Now put the top packing cushion in place.
 - ⇒ Taking care to position it correctly.
- 2 Pass the lifting strap around both packing cushions, **see** illustration.
- 3 Tighten it until it lies close against the packaging.
 - ⇒ You can now lift the packed balance by the lifting strap and insert it into the transport carton.



- Place the packaging with the outer draft shield and AC adapter sets on the balance in the transportation carton.

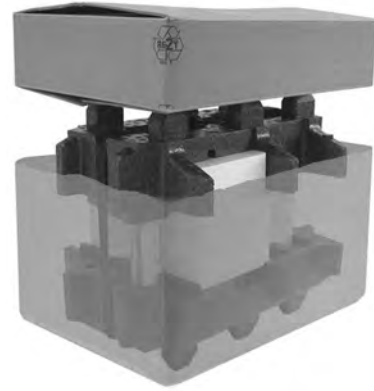

4.9 Installing the ErgoClip

Attention

Before you install an ErgoClip you must switch off the balance [On/Off] key.

To install the ErgoClip included in the delivery, or an optional ErgoClip, please proceed as follows:

- 1 Remove the grid weighing pan (SmartGrid) from the balance.
- 2 Insert the support (1) for the "ErgoClip Basket micro".
- 3 Place the basket (2) on the guide (3) of the support.
- 4 Switch the balance on again [On/Off] key.

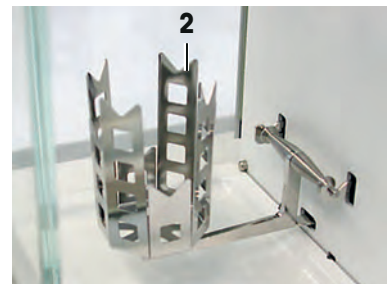

Important to know!

If you do not switch the balance off before you do the installation, the ProFACT function is not activated.

Reason

Addition of the ErgoClip causes the dead-load tolerance range of the balance to be exceeded. The balance therefore does not activate ProFACT, so as not to interrupt the **assumed** weighing operation.

When this status icon appears in the display, it means: "The balance wants to execute ProFACT" but cannot.



4.10 Installing the Grid Weighing Pan Cover

Note

For standard operation with conventional tare containers, we do **not** recommend using this weighing pan. Its use may affect the stabilization time and degree of accuracy. The listed specifications are reached without a weighing pan.



CAUTION

Hand injuries

Take care when handling the weighing pan, the corners and edges are extremely sharp!

Attention

With installed grid weighing pan cover, the balance does not switch to "Standby" mode!

- 1 For the installation, remove the grid weighing pan from the weighing chamber.
- 2 Gently press the cover onto the grid weighing pan.
- 3 Replace the grid weighing pan with the installed grid weighing pan cover.

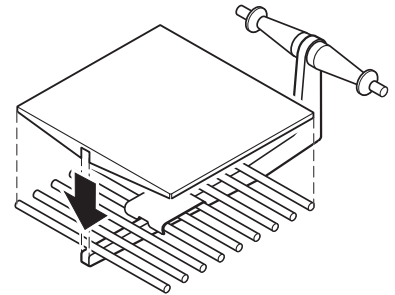

5 First Steps

5.1 Switching On / Off

Switching On

- Press [**On/Off**].
- ⇒ The display appears.



Note

If the balance has not been set up exactly horizontally, a warning text will appear shortly after the balance is turned on, prompting you to level the balance, **see** Leveling the Balance (page 28).

Switching Off

- Press [**On/Off**] until "Off" appears in the display.



Note

Do not disconnect the balance from the power supply except if you will not be using the balance for an extended period.

5.2 Leveling the Balance

Your balance has a built-in levelcontrol, that constantly checks the correct horizontal alignment.

When the levelcontrol detects that the level is incorrect, a warning will appear and a warning beep will sound. A status icon will also appear in the upper right-hand corner of the display.



- 1 To start the Leveling Assistant, tap [**Info**].
 - ⇒ The Leveling Assistant will guide you step by step through the leveling process.
- 2 Watch the levelcontrol located of your balance and press the appropriate button of the current position.
 - ⇒ The Leveling Assistant will show you with red arrows in which direction you need to turn the two footscrews on the back of the balance.
- 3 Screw the footscrew until the air bubble is in the inner circle.
- 4 Tap [**Exit**].
 - ⇒ A message appears that advises you to adjust the balance.
- 5 Confirm with [**OK**].
 - ⇒ Status icon will no longer appear and balance returns to normal operation.

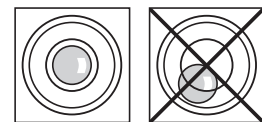
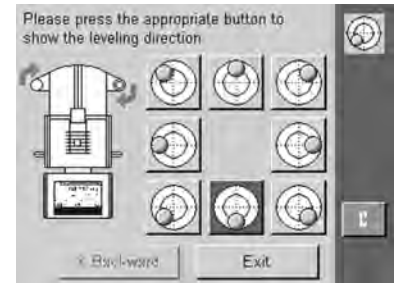
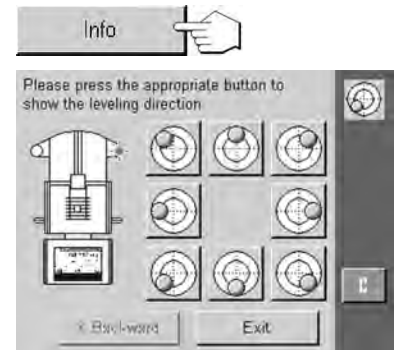

6 Special Settings for XP56/XP26/XP205CDR/XP505 Comparator Balances

To fully utilize the high resolution of the balance, some specific rules must be observed. These will enable you to obtain the best possible results.

- ▶ Take care to choose a good location **see** Selecting a Location (page 14).
- Operate the balance on a stone bench.
- ⇒ Other surfaces can have a negative effect on the weighing performance.

6.1 Load the Balance

Because of the high resolution of the balance, even minute differences of temperature or humidity can affect the result. Make sure that the weighing chamber and hanging weighing pan are clean and that the weighing sample is acclimatized.



CAUTION

Damage of Device

Do not use the sealing cover to lift the top glass of the draft shield.

- 1 Do not touch the reference and test weights with your hands.
- 2 Always use suitable tweezers for loading and unloading the balance.

The sealing cover in the top glass of the inner draft shield closes the opening in the glass through which you can pipette into a high container.

6.2 Settings for the Outer and Inner Draft Shield

Operation of the draft shield doors is the same for the outer and the inner draft shield. You can set the door opening separately in steps of 25 % to 100 %.

Depending on your settings for the coupling elements, **see** Operating of the Outer Draft Shield and the Inner Draft Shield (page 20), you determine which doors will be opened.

- Only open the doors that are necessary for loading.

Changing the settings for the draft shield doors

- Press 
- ⇒ Window "User Setting" opens.



In this menu you can adjust the function of the doors of the outer- /and inner draft shield to your requirements.

- Tap 
- ⇒ Window "Door" opens.

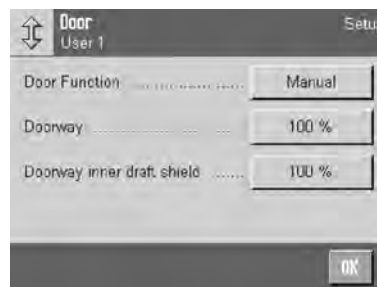

Door Function

- 1 To operate the doors manually, you tap the [↕] key or use SmartSens.
 - 2 Activate the Automatic door function.
- ⇒ The doors of the outer and inner draft shields open and close automatically whenever necessary.

Example

- When you press the [→T←] key, the doors open automatically to allow you to place the tare weight on the pan.
- When you are prompted to place the adjustment weight on the pan while you are adjusting the balance, the doors automatically open. As soon as you have placed the weight on the pan, the doors automatically close again.
- The doors will close automatically whenever this is required to reach a stable weight value.
- The doors open and close automatically during many work processes (e.g. piece counting), depending on the current requirements of the application.

Factory setting: [**Manual**]

Doorway and Doorway inner draft shield

Doorway Opening width of the outer draft shield.

Doorway inner draft shield Opening width of the inner draft shield (XP56/XP26).

This setting allows you to define how wide the doors of the outer- and inner draft shield open (automatically or manually). If you select the 100 % setting, the doors will open all the way. If you select [25 %], however, the doors will open only a quarter of the way. Two other intermediate settings can be selected.

If your application allows it, you can reduce the opening of the doors. This shortens the opening and closing times, making environmental influences (drafts) less bothersome.

Factory setting: [**100 %**]

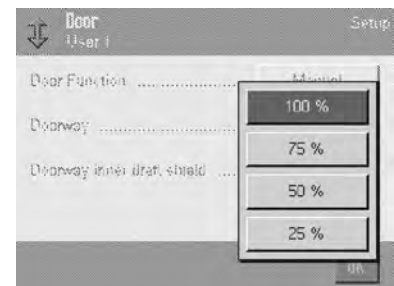
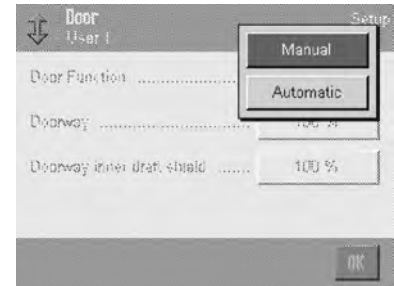

6.3 Settings for the Comparators

6.3.1 Settings of the Standard Types XP56/XP26/XP205CDR/XP505 Comparator Balances

AutoZero

Is switched off at initial operation and after a factory reset (resetting to the factory settings), but can be switched on again when required."

When changing over to the "WeighCom" application, "**AutoZero**" is automatically switched off. When changing back to the "Weigh" application, the previous status of "**AutoZero**" is restored.

Attention

When comparing masses, "**AutoZero**" must not be switched on, because it can distort the measurement values.

ProFACT

Is switched off at initial operation and after a factory reset (resetting to the factory settings). When comparing masses, it is not advisable to switch **ProFACT** on.

6.3.2 Settings of the Certified Version XP56/A, XP56/M, XP26/A, XP26/M Comparator Balances

AutoZero	On certified balances, " AutoZero " must be switched on, but can be switched off if required.
ProFACT	Is switched on at initial operation and after a factory reset (resetting to the factory settings), but can be switched off when required. When changing over to the "WeighCom" application, " AutoZero " is automatically switched off. When changing back to the "Weigh" application, the previous status of " AutoZero " is restored.
Autom. ext. Adjust.	Attention Is not allowed for certified balances. This function must be performed by a service technician.

7 Maintenance

7.1 Cleaning

Periodically clean the weighing chamber, the housing, and the terminal of your balance using the brush supplied with it. The maintenance interval depends on your standard operating procedure (SOP).

Please observe the following notes



WARNING

Damage of balance

- The balance must be disconnected from the power supply.
 - Ensure that no liquid comes into contact with the balance, the terminal or the AC adapter.
 - Never open the balance, terminal or AC adapter – they contain no components, which can be cleaned, repaired or replaced by the user.
-



CAUTION

Damage of balance

On no account use cleaning agents which contain solvents or abrasive ingredients, as this can result in damage to the terminal overlay.

Cleaning

Your balance is made from high quality, resistant materials and can therefore be cleaned with a commercially available, mild cleaning agent.

- 1 To clean the weighing chamber thoroughly, swivel the glasses of the draft shields (inner and outer draft shield) away from the balance and pull them out of their fastenings. It may be necessary to turn the weighing pan slightly to remove it.
- 2 Carefully raise the front of the weighing pan and lift it out of the guide.
- 3 Pull the drip tray away from the balance.
- 4 When you replace these parts, make sure they are in the correct position.

Note

Please contact your METTLER TOLEDO dealer for details of the available service options. Regular servicing by an authorized service engineer ensures constant accuracy for years to come and prolongs the service life of your balance.

7.2 Disposal

In conformance with the European Directive 2002/96/EC on Waste Electrical and Electronic Equipment (WEEE) this device may not be disposed of in domestic waste. This also applies to countries outside the EU, per their specific requirements.

Please dispose of this product in accordance with local regulations at the collecting point specified for electrical and electronic equipment. If you have any questions, please contact the responsible authority or the distributor from which you purchased this device. Should this device be passed on to other parties (for private or professional use), the content of this regulation must also be related.

Thank you for your contribution to environmental protection.



8 Technical Data

8.1 General Data



CAUTION

Use only with a tested AC Adapter with SELV output current.
Ensure correct polarity

Power supply

Power supply connector with AC/DC adapter:	11107909 Primary: 100-240 VAC, -15%/+10%, 50/60 Hz Secondary: 12 VDC \pm 3%, 2.0 A (with electronic overload protection)
Cable to AC adapter:	Design: 3-core, with country-specific plug
Power supply to the balance:	Note Make sure the power supply plug is freely accessible 12 VDC \pm 3%, 2.0 A, maximum ripple: 80 mVDCpp

Protection and standards

Overvoltage category:	Class II
Degree of pollution:	2
Protection:	Protected against dust and water
Standards for safety and EMC:	See Declaration of Conformity
Range of application:	For use only in closed interior rooms

Environmental conditions

Height above mean sea level:	Up to 4000 m
Ambient temperature:	10-30 °C
Relative air humidity:	40% – 70%
Warm-up time:	At least 12 hours after connecting the balance to the power supply. The balance should not be switched into standby mode.

Materials

Housing:	Die-cast aluminum, plastic, chrome steel and glass
Terminal:	Die-cast zinc, chromed and plastics
Hanging weighing pan and Grid weighing pan:	Chrome-nickel steel X5CrNi18-10

8.2 Explanatory Notes for the METTLER TOLEDO AC Adapter

The certified external power supply which conforms to the requirements for Class II double insulated equipment is not provided with a protective earth connection but with a functional earth connection for EMC purposes. This earth connection IS NOT a safety feature. Further information about conformance of our products can be found in the brochure "Declaration of Conformity" which is coming with each product.

In case of testing with regard to the European Directive 2001/95/EC the power supply and the balance have to be handled as Class II double insulated equipment.

Consequently an earth bonding test is not required. Similarly it is not necessary to carry out an earth bonding test between the supply earth conductor and any exposed metalwork on the balance.

Because the balance are sensitive to static charges a leakage resistor, typically 10 k Ω , is connected between the earth connector and the power supply output terminals. The arrangement is shown in the equivalent circuit

diagram. This resistor is not part of the electrical safety arrangement and does not require testing at regular intervals.

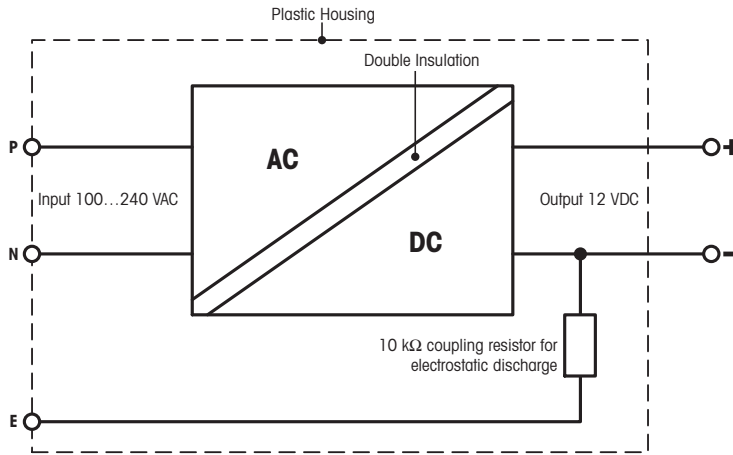

Equivalent circuit diagram

8.3 Model-specific Data

		XP26 Comparator	XP56 Comparator
Limit values			
Maximum capacity		22 g	52 g
Readability		0.001 mg	0.001 mg
Tare range (from...to)		0 ... 22 g	0 ... 52 g
Repeatability (at nominal load)	sd	0.002 mg (22 g)	0.0045 mg (52 g)
Repeatability (at nominal load) (ABA, measured at) ¹⁾	sd	0.0015 mg (20 g)	0.003 mg (50 g)
Repeatability (at low load) (ABA, measured at) ¹⁾	sd	0.0007 mg (1 g)	0.0007 mg (1 g)
Linearity deviation		0.006 mg	0.020 mg
Eccentricity deviation (test load)		0.00 mg (20 g)	0.00 mg (50 g)
Sensitivity offset (test weight) ²⁾		0.08 mg (20 g)	0.125 mg (50 g)
Sensitivity temperature drift		0.0001 %/°C	0.0001 %/°C
Sensitivity stability		0.0001 %/a	0.0001 %/a
Typical values			
Repeatability ¹⁾	sd	0.0015 mg (22 g)	0.003 mg (52 g)
Repeatability ABA ¹⁾	sd	0.0016 mg (20 g)	0.0027 mg (50 g)
Linearity deviation		0.0016 mg	0.0051 mg
Eccentric deviation (test load) ³⁾		0.003 mg (10 g)	0.006 mg (20 g)
Sensitivity offset (test load) ²⁾		0.02 mg (20 g)	0.03 mg (50 g)
Minimum sample weight (according to USP) ¹⁾		2.1 mg	2.1 mg
Minimum sample weight (U=1%, k=2) ¹⁾		0.14 mg	0.14 mg
Settling time		3.5 s	3.5 s
Dimensions			
Balance dimensions (WxDxH)		263x487x322 mm	263x487x322 mm
Grid weighing pan dimensions		40x40 mm (WxD)	40x40 mm (WxD)
Hanging weighing pan dimensions		∅ 35 mm	∅ 35 mm
Typical uncertainties and supplementary data			
Repeatability ¹⁾	sd	0.0007 mg + 0.0000038 %·Rgr	0.0007 mg + 0.0000046 %·Rgr
Repeatability (ABA, measured at) ¹⁾	sd	0.0007 mg + 0.0000042 %·Rgr	0.0007 mg + 0.000004 %·Rgr
Differential linearity deviation	sd	√(0.12pg·Rnt)	√(0.5pg·Rnt)
Differential eccentric load deviation ³⁾	sd	0.00003 %·Rnt	0.00003 %·Rnt
Sensitivity offset ²⁾	sd	0.0001 %·Rnt	0.00012 %·Rnt
Minimum sample weight (according to USP) ¹⁾		2.1 mg + 0.0114 %·Rgr	2.1 mg + 0.0138 %·Rgr
Minimum sample weight (U=1%, k=2) ¹⁾		0.14 mg + 0.0008 %·Rgr	0.14 mg + 0.0009 %·Rgr
Weighing time		36 s	36 s

	XP26 Comparator	XP56 Comparator
Interface update rate	23/s	23/s
Usable height of draft shield	72 mm	72 mm
Weight of balance	11.5 kg	11.5 kg
Number of built-in reference weights	2	2
Weights for routine testing		
OIML CarePac	20 g F1, 1 g E2	50 g F2, 2 g E2
Weights	#11123006	#11123003
ASTM CarePac	20 g 1, 1 g 1	50 g 1, 2 g 1
Weights	#11123106	#11123103

sd = Standard deviation

Rnt = Net weight (sample weight)

Rgr = Gross weight

a = Year (annum)

1) Valid for compact objects

2) After adjustment with built-in reference weight

3) Only with the grid weighing pan. With the hanging weighing pan the value = 0 (zero).

	XP205CDR Comparator	XP505 Comparator
Limit values		
Maximum capacity	220 g	520 g
Readability	0.1 mg	0.01 mg
Tare range (from...to)	0 ... 220 g	0 ... 520 g
Readability, fine range	0.01 mg	–
Repeatability (at nominal load)	sd 0.060 mg (220 g)	0.06 mg (520 g)
Repeatability (at nominal load) (ABA, measured at) ¹⁾	sd 0.050 mg (200 g)	0.035 mg (500 g)
Repeatability (at low load) (ABA, measured at) ¹⁾	sd 0.015 mg (10 g)	0.01 mg (50 g)
Linearity deviation	0.15 mg	0.1 mg
Eccentricity deviation (test load)	0.25 mg (100 g)	0.2 mg (200 g)
Sensitivity offset (test weight) ²⁾	0.5 mg (200 g)	1.25 mg (500 g)
Sensitivity temperature drift	0.0001 %/°C	0.0001 %/°C
Sensitivity stability	0.0001 %/a	0.0001 %/a
Typical values		
Repeatability ¹⁾	sd 0.027 mg (220 g)	0.041 mg (520 g)
Repeatability ABA ¹⁾	sd 0.0175 mg (200 g)	0.031 mg (500 g)
Linearity deviation	0.051 mg	0.079 mg
Eccentric deviation (test load) ³⁾	0.05 mg (100 g)	0.1 mg (200 g)
Sensitivity offset (test load) ²⁾	0.16 mg (200 g)	0.25 mg (500 g)
Minimum sample weight (according to USP) ¹⁾	21 mg	45 mg
Minimum sample weight (U=1%, k=2) ¹⁾	1.4 mg	3 mg
Settling time	1.5 s	5 s
Settling time, fine range	2.5 s	–
Dimensions		
Balance dimensions (WxDxH)	263x487x322 mm	263x487x322 mm
Grid weighing pan dimensions	78x73 mm (WxD)	78x73 mm (WxD)
Typical uncertainties and supplementary data		
Repeatability ¹⁾	sd 0.04 mg + 0.000005 %-Rgr	0.04 mg + 0.000006 %-Rgr
Repeatability, fine range ¹⁾	sd 0.007 mg + 0.000012 %-Rgr	–
Repeatability (ABA, measured at) ¹⁾	sd 0.007 mg + 0.0000084 %-Rgr	0.008 mg + 0.0000046 %-Rgr
Differential linearity deviation	sd $\sqrt{12}$ pg·Rnt	$\sqrt{50}$ pg·Rnt
Differential eccentric load deviation ³⁾	sd 0.00005 %-Rnt	0.00005 %-Rnt
Sensitivity offset ²⁾	sd 0.00008 %-Rnt	0.00005 %-Rnt
Minimum sample weight (according to USP) ¹⁾	21 mg + 0.036 %-Rgr	45 mg + 0.015 %-Rgr
Minimum sample weight (U=1%, k=2) ¹⁾	8 mg + 0.001 %-Rgr	3 mg + 0.001 %-Rgr
Weighing time	24 s	36 s
Weighing time, fine range	36 s	–
Interface update rate	23/s	23/s
Usable height of outer draft shield	235 mm	235 mm

		XP205CDR Comparator	XP505 Comparator
Weight of balance		10 kg	10 kg
Number of built-in reference weights		2	2
Weights for routine testing			
OIML CarePac		200 g F2, 10 g F1	500 g F2, 20 g F1
	Weights	#11123001	#11123007
ASTM CarePac		200 g 1, 10 g 1	500 g 1, 20 g 1
	Weights	#11123101	#11123107

sd = Standard deviation

Rnt = Net weight (sample weight)

Rgr = Gross weight

a = Year (annum)

1) Valid for compact objects

2) After adjustment with built-in reference weight

3) Only with the grid weighing pan. With the hanging weighing pan the value = 0 (zero).

8.4 Dimensions

8.4.1 Dimensions of the XP56/XP26 Comparators

Dimensions in mm.

With hanging weighing pan

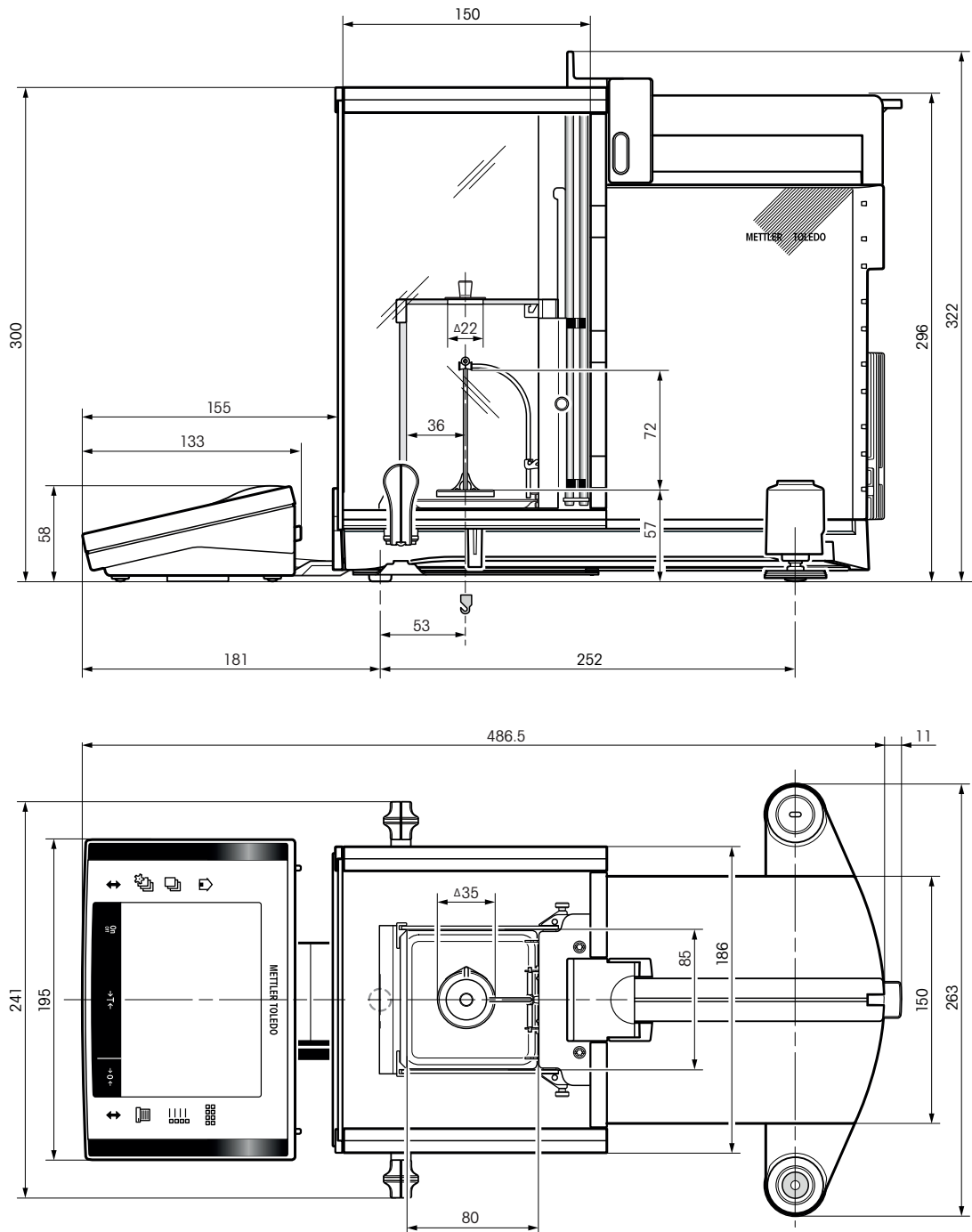

XP56/XP26 Comparator with Hanging weighing pan

With grid weighing pan

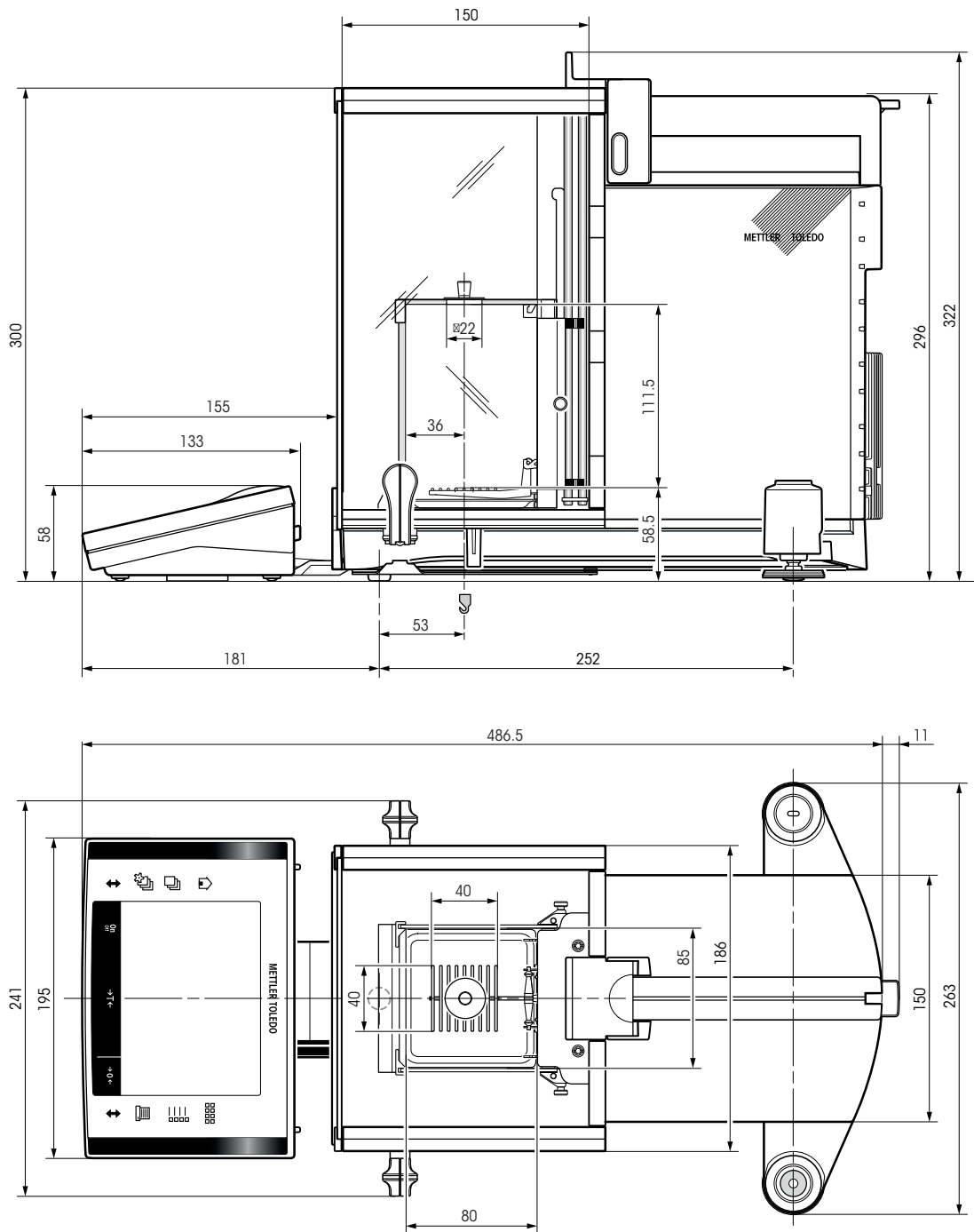

XP56/XP26 Comparator with grid weighing pan

8.4.2 Dimensions of the XP205CDR/XP505 Comparators

Dimensions in mm.

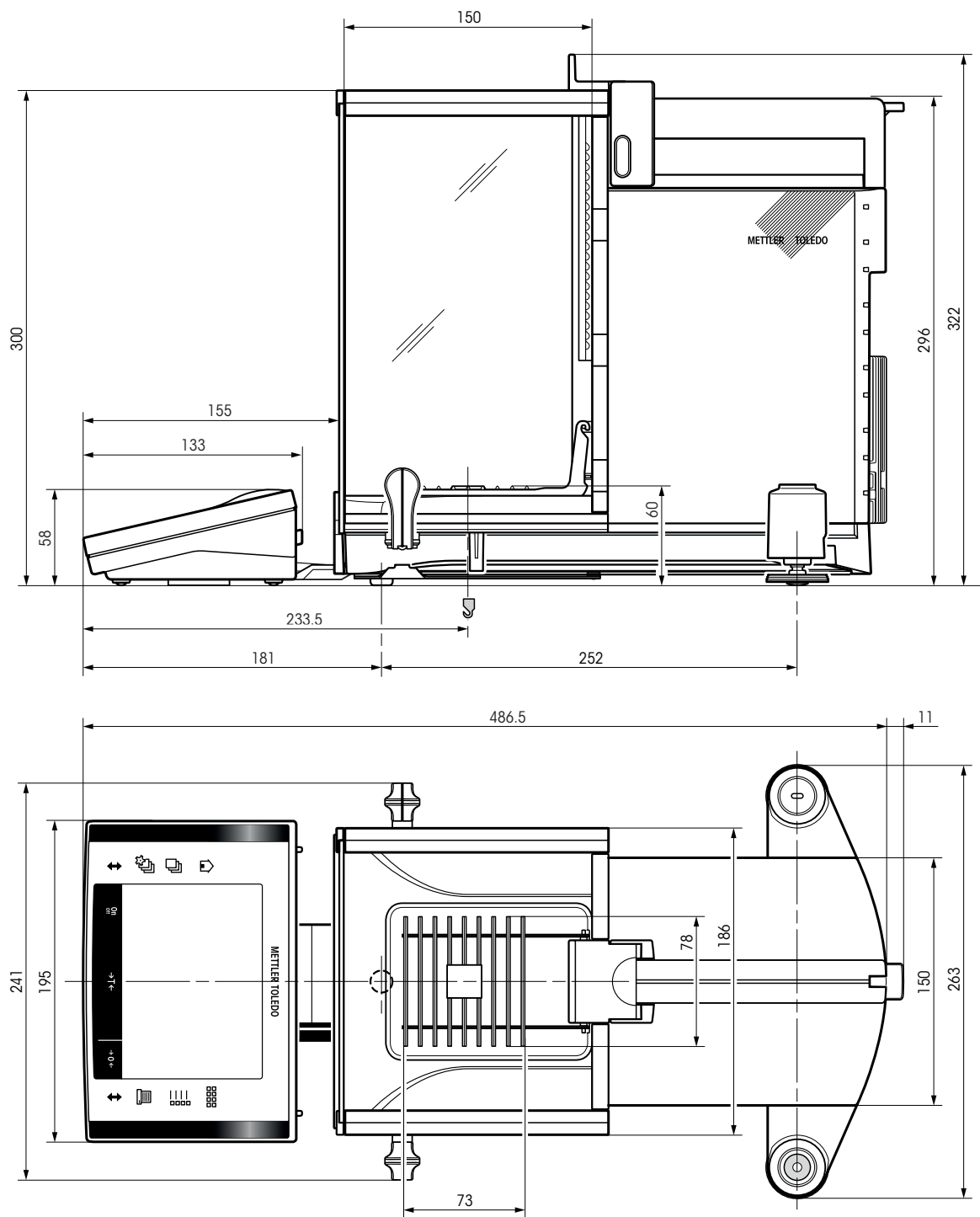

XP205CDR/XP505 Comparators

8.5 Interfaces

8.5.1 Specifications of RS232C

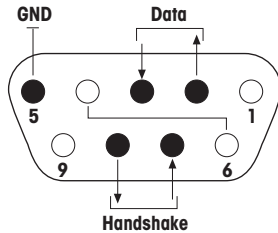
Interface type:	Voltage interface according to EIA RS-232C/DIN 66020 (CCITT V24/V.28)	
Max. cable length:	15 m	
Signal level:	Outputs: +5 V ... +15 V (RL = 3 – 7 kΩ) –5 V ... –15 V (RL = 3 – 7 kΩ)	Inputs: +3 V ... 25 V –3 V ... 25 V
Connector:	Sub-D, 9-pole, female	
Operating mode:	Full duplex	
Transmission mode:	Bit-serial, asynchronous	
Transmission code:	ASCII	
Baud rates:	600, 1200, 2400, 4800, 9600, 19200, 384001) (firmware selectable)	
Bits/parity:	7-bit/even, 7-bit/odd, 7-bit/none, 8-bit/none (firmware selectable)	
Stop bits:	1 stop bit	
Handshake:	None, XON/XOFF, RTS/CTS (firmware selectable)	
End-of-line:	<CR><LF>, <CR>, <LF> (firmware selectable)	
	Pin 2: Balance transmit line (TxD) Pin 3: Balance receive line (RxD) Pin 5: Ground signal (GND) Pin 7: Clear to send (hardware handshake) (CTS) Pin 8: Request to send (hardware handshake) (RTS)	

8.5.2 Specifications of "Aux" Connection

You can connect the METTLER TOLEDO "ErgoSens" or an external switch to sockets "Aux 1" and "Aux 2". This allows you to start functions such as taring, zeroing, printing and others.

External connection

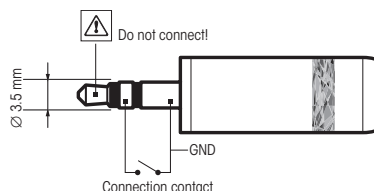

Connector:	3.5 mm stereo jack connector	
Electrical data:	Max. voltage	12 V
	Max. current	150 mA



9 Accessories and Spare Parts

9.1 Accessories

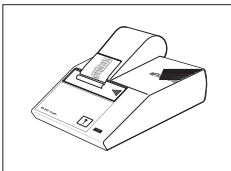
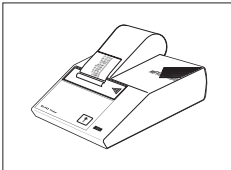
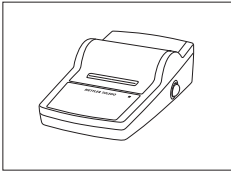
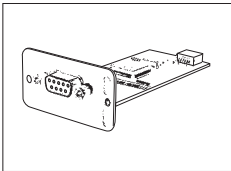
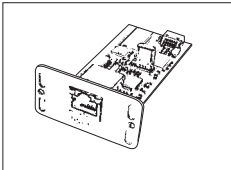
You can increase the functionality of your balance with accessories from the METTLER TOLEDO range. The following options are available:

	Description	Part No.
Printers		
	BT-P42 printer with Bluetooth connection to instrument	11132540
	Paper roll, set of 5 pcs	00072456
	Paper roll, self-adhesive, set of 3 pcs	11600388
	Ribbon cartridge, black, set of 2 pcs	00065975
	RS-P42 printer with RS232C connection to instrument	00229265
	Paper roll, set of 5 pcs	00072456
	Paper roll, self-adhesive, set of 3 pcs	11600388
	Ribbon cartridge, black, set of 2 pcs	00065975
	RS-P25 printer with RS232C connection to instrument	11124300
	Paper roll, set of 5 pcs	00072456
	Paper roll, self-adhesive, set of 3 pcs	11600388
	Ribbon cartridge, black, set of 2 pcs	00065975
Optional interfaces		
	Second RS232C Interface	11132500
	Ethernet Interface for connection to an Ethernet network	11132515
	BT option: Bluetooth Interface for multipoint connection for up to 6 Bluetooth devices	11132530



BTS option: Bluetooth Interface, single-point connection

11132535



PS/2 option: Interface for connecting commercial keyboards and barcode readers

11132520



LocalCAN option: Interface for connection of up to 5 LC (Local-CAN) instruments

11132505



MiniMettler option: Interface MiniMettler, for connection to older (legacy) METTLER TOLEDO systems

11132510

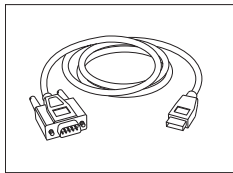

RS232 - USB converter cable – Cable with converter to connect a balance (RS232) to a USB port

64088427

Cables for RS232C interface

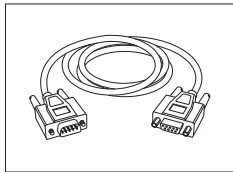

RS9 – RS9 (m/f): connection cable for PC, length = 1 m

11101051

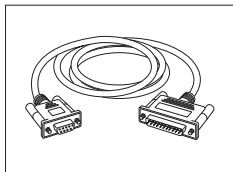

RS9 – RS25 (m/f): connection cable for PC, length = 1 m

11101052

Cables for LocalCAN Interface

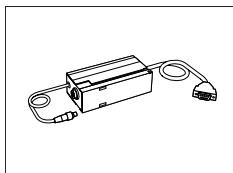

LC – RS9: Cable for connecting a PC with RS232C, 9-pin (f), length = 2 m

00229065

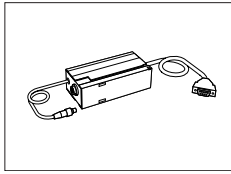

LC – RS25: Cable for connecting a printer or PC with RS232C, 25-pin (m/f), length = 2 m

00229050



LC – CL: Cable for connecting a device with METTLER TOLEDO CL interface (5-pin), length = 2 m

00229130



LC – LC2: Extension cable for LocalCAN, length = 2 m

00229115

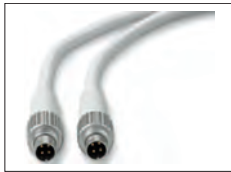

LC – LC5: Extension cable for LocalCAN, length = 5 m

00229116



LC – LCT: Cable branch (T-connector) for LocalCAN

00229118

Cables for MiniMettler Interface

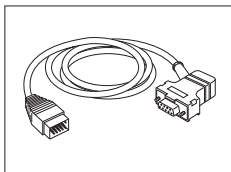

MM – RS9f: RS232C connection cable to MiniMettler interface, length = 1.5 m

00229029

Cables for Terminal

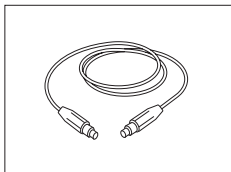

Terminal extension cable, length = 4.5 m

11600517

Cable, one-sided open (2-pin)

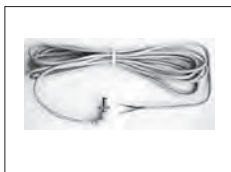

Cable between balance and AC adapter, length = 4 m

11132037

Auxiliary displays

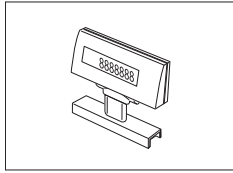

BT-BLD Bluetooth auxiliary display for table mounting,
168 mm, LCD display with backlighting

11132555

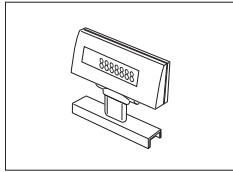

LC/RS-BLD auxiliary display on bench stand, backlit (incl. RS
cable and separate AC adapter)

00224200



RS/LC-BLDS auxiliary display for table or balance mounting,
480 mm, LCD display with backlighting

11132630

Sensors

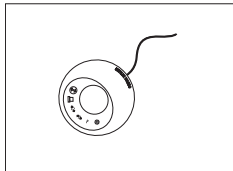

ErgoSens, optical sensor for hands-free operation

11132601

LC-Switchbox



For connection of up to 3 balances with LocalCAN interface to
a printer

00229220

Footswitches

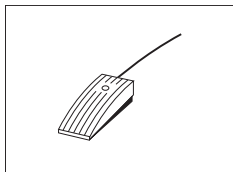

Footswitch with selectable function for balances (Aux 1, Aux 2)

11106741



LC-FS foot switch with selectable function for balances with
LocalCAN interface

00229060

AntiStatic Kit Integrable Point-Electrode



Integrable antistatic kit incl. 1 point-electrode and power supply

11107761

Optional: Second point-electrode*

11107762

Optional: U-electrode*

11107764

* Regulated power supply for optional, second point-electrode 11107762, or the optional U-electrode 11107764

11107763

Universal AntiStatic Kit



Universal antistatic kit complete U-shaped, including electrode and power supply

11107767

Optional: Second U-electrode*

11107764

Optional: Point-electrode*

11107765

* Power supply for optional, second U-electrode 11107764, or for optional point-electrode 11107765

11107766

ErgoClips



ErgoClip "Basket micro" (basket for small weighing objects)

11107889



ErgoClip "Flask micro" (for volumetric flask)

11107879



ErgoClip "Stand micro" (Holder to store up to 3 ErgoClips)

11140175

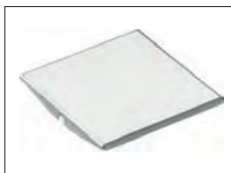

SmardGrid Cover, chromium-nickel steel

11106262



Single-use weighing boats, 500 units

11106712



MinWeigh Door micro ideal for use with ErgoClip "Flask micro"

11107869

XP-SE Kit



Separate electronics kit

11106743

Extension cable 0.6 m

00211535

Extension cable 5.0 m

00210688

Barcode Reader

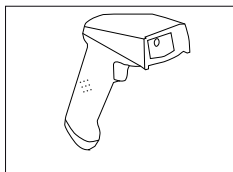

RS232C Barcode Reader

21901297

The following accessories are needed for operation (not included):

RS232 F cable 21901305

Null modem adapter 21900924

Plus one of the following:

AC adapter 5 V for EU 21901370

AC adapter 5 V for US 21901372

AC adapter 5 V for GB 21901371

AC adapter 5 V for AU 21901370

+ 71209966

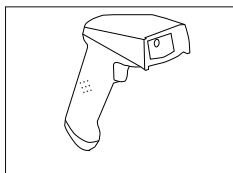

RS232C Barcode Reader – Cordless

21901299

The following accessories are needed for operation (not included):

Cradle 21901300

RS232 F cable 21901305

Null modem adapter 21900924

Plus one of the following:

AC adapter 12 V for EU 21901373

AC adapter 12 V for US 21901375

AC adapter 12 V for GB 21901374

AC adapter 12 V for AU 21901373

+ 71209966

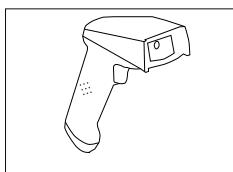

PS/2 Barcode Reader, without cable

21901297

PS/2 wedge single cable

21901307

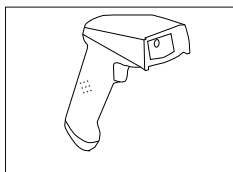

PS/2Y Barcode Reader, without cable

21901297

PS/2 wedge twin (Y) cable

21901308

Anti-theft devices

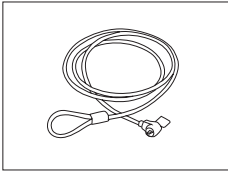

Steel cable

11600361

Transport Cases



Transport case

11106729

Protective Covers

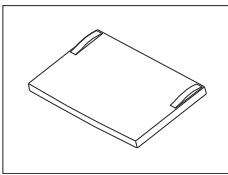

Protective cover for XP terminal

11132570

Dust covers



Dust cover

30035838

Software

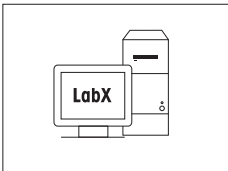

LabX Software for One Click™ Weighing Solutions

on request

Enables you to perform One Click™ Standard Preparation, One Click™ Loss on Drying, One Click™ Sieve Analysis and many other applications.

Simply start the method with the One Click™ shortcut on the balance touchscreen. LabX guides you step-by-step through the SOP on the balance, performs your calculations automatically, and takes care of saving all your data. The complete solution can be tailored to match your process requirements.

Visit www.mt.com/one-click-weighing for more information

Freeweigh.Net

21900895

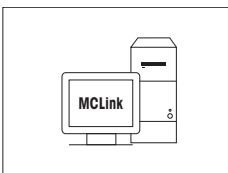

MCLink Mass Comparator Control Software

11116504

MCLink software – a simple and practical tool for carrying out your mass measurements to a high level of efficiency. MCLink is the ideal tool for facilities from small calibration laboratories up to scientific mass laboratories. Reports are generated safely and efficiently with direct control of the comparators with one click.

Various



Terminal and printer stand, mounting on balance

11106730

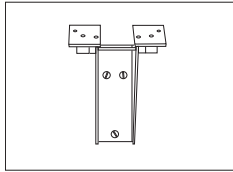

Wall fixture for terminal

11132665

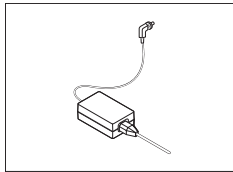

AC/DC adapter (without power cable) 100–240 VAC,
50/60 Hz, 0.3 A, 12 VDC 2.25 A

11107909

- Power cable CH 00087920
- Power cable EU 00087925
- Power cable US 00088668
- Power cable IT 00087457
- Power cable DK 00087452
- Power cable GB 00089405
- Power cable AU 00088751
- Power cable ZA 00089728
- Power cable BR 30015268
- Power cable JL 00225297
- Power cable IN 11600569
- Power cable JP 11107881
- Power cable TH, PE 11107880

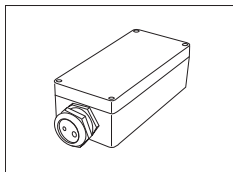

IP54 protective housing for AC adapter

11132550

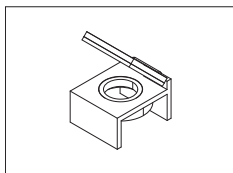

Level bubble mirror

11140150

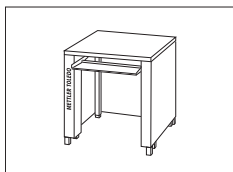

Weighing table

11138042

Reference weights



Reference weight E1 20 g SCS certified

00159131

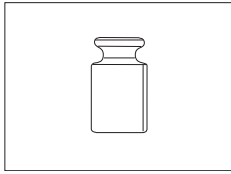

Reference weight E1 50 g SCS certified

00159141

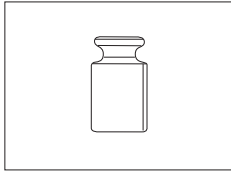

Reference weight E1 200 g SCS certified

00159161

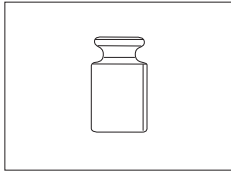



Reference weight E1 500 g SCS certified

00159171

9.2 Spare Parts

	Pos	Description	Part No.
	1	Side draft shield door	11106841
	2	Top draft shield door	11106842
	3	Front glass	11106843
	4	Intermediate shelf	11106803
	5	Grid weighing pan cover	11106709
	6	Grid weighing pan	11106333
	7	Clip (Set of 6 pieces)	11106511
	8	Foot screw	11106323
	9	Terminal support	11106540
	10	Drip tray	11106449
		XP Terminal complete with firmware	11130835

	Pos	Description	Part No.
		Packaging complete XP56/XP26	11107998
		Packaging complete XP205CDR/XP505	11106879
	Export box XP56/XP26	11106657	
	Export box XP205CDR/XP505	11106871	

10 Appendix

10.1 MT-SICS Interface Commands and Functions

Many of the instruments and balances used have to be capable of integration in a complex computer or data acquisition system.

To enable you to integrate balances in your system in a simple manner and utilize their capabilities to the full, most balance functions are also available as appropriate commands via the data interface.

All new METTLER TOLEDO balances launched on the market support the standardized command set "METTLER TOLEDO Standard Interface Command Set" (MT-SICS). The commands available depending on the functionality of the balance.

For further information please refer to the Reference Manual MT-SICS downloadable from the Internet under

► <http://www.mt.com/comparators>

10.2 Procedure for Certified Balances

Preface

Certified balances are subject to the national, legal requirements of "non-automatic balances".

Switching on the balance

- **Switching on**
 - Immediately after being switched on, the balance displays 0.000.. g.
 - The balance is always started up with the "Factory setting" unit.
- **Switch-on range**
 - At maximum 20% of the type load, otherwise overload is displayed (OIML R76 4.5.1).
- **Stored value as switch-on zero point**
 - It is not permissible to use a stored value as a switch-on zero point; the MT-SICS M35 command is not available (OIML R76 T.5.2).

Display

- **Display of the weight value**
 - The "e" certification value is always shown in the display and is specified at the model designation plate (OIML R76 T.3.2.3 and 7.1.4).
 - If the display increment is lower than the "e" certification value, this is variably displayed for the net, gross and weighed tare. (Graying of the digits or certification brackets) (OIML R76 T.2.5.4 and 3.4.1).
- In accordance with guidelines, the tested display increment (certification value) is never lower than 1 mg (OIML R76 T.3.4.2).
- At balances with $d = 0.1$ mg, the digits below 1 mg are displayed in gray. These digits in brackets are printed. In accordance with legal metrology requirements, this illustration does not affect the accuracy of the weighing results.
- **Units of measurement**
 - The display and info unit are firmly set to g or mg (depending on the model).
 - The following applies for the "Custom unit":
 - No certification brackets.
 - The following names are blocked, this applies to upper and lower case letters.
 - All official units (g, kg, ct etc.).
 - c, ca, car, cm, crt, cart, kt, gr, gra, gram, grm, k, kilo, to, ton.
 - All names with "o" which can be replaced by a zero (Oz, Ozt etc.).

- **Identification of the weight display**

- Gross, net, tare and other weight values are accordingly marked (OIML R76 4.6.5).
 - Net for net when a tare value has been used.
 - B or G for gross.
 - T for the weighed tare.
 - PT for the specified tare.
 - * or diff for the difference between the net or gross.

- **Info field**

- The info weight value is handled metrologically in the same way as the weight value in the main display.

Printout (OIML R76 4.6.11)

- If a tare value is entered manually (PreTare), the PreTare value is always printed along with the net value (PT 123.45 g).
- The printed weight values are identified in the same way as the weight value on the display. I.e. N, B or G, T, PT, diff or *, with differentiation.

Example:

Single-range balance.

N	123.4[5] g
PT	10.00 g → for PreTare
G	133.4[5] g

DR balance with 100.00 g fine range.

N	80.4[0] g
T	22.5[6] g → for weighed tare
G	102.9[] g

Balance functions

- **Reset to zero**

- The zero range is limited to a maximum of $\pm 2\%$ of the full load (OIML R76 4.5.1).

- **Tare**

- No negative tare values are permitted.
- Tare immediate (TI) is not permitted, the MT-SICS `TI` command is not available (OIML R76 4.6.4).

- **1/xd**

- **e = d**

The 1/xd switchover is not permitted (OIML R76 3.1.2).

- **e = 10d**

This is only permitted in the case of the 1/10d switchover.

- **e = 100d**

Only the 1/10d and 1/100d switchover are permitted.

11 Index

A	
AC Adapter	34
AC adapter	34
Accessories	42
Automatic door function	31
Aux Connections	41
<hr/>	
B	
Balance functions	53
<hr/>	
C	
Certified balances	52
Cleaning	33
Conventions	6
<hr/>	
D	
Dimensions	38, 40
Display	52
Display field remains dark	20
Display of the weight value	52
Disposal	33
Door function	31
Doorway	31
<hr/>	
E	
Environmental conditions	34
ErgoClip	12, 26
ErgoSens	41
<hr/>	
F	
Features	5
<hr/>	
G	
GLP	5
Good Laboratory Practice	5
Grid weighing pan	15
<hr/>	
H	
Hanging weighing pan	15
<hr/>	
I	
Identification of the weight display	53
Info field	53
Inner draft shield	15, 21, 30
Installing the grid weighing pan cover	26
Interface	
MT-SICS	52
ISO 14001	5
ISO 9001	5
<hr/>	
L	
Level sensor	28
Levelcontrol	28
Leveling Assistant	29
Load the balance	30

Location	30
<hr/>	
M	
Materials	34
MT-SICS	52
<hr/>	
O	
Outer draft shield	20, 30
Overview	9, 10
<hr/>	
P	
Pack	23
Power supply	19, 34
Power supply voltages	19
Printout	53
Protection and standards	34
<hr/>	
R	
Remove terminal	21
Reset to zero	53
RS232C Interface	41
<hr/>	
S	
safety information	7
Scope of delivery	13
Self test	20
Setting the reading angle	21
Setting up	11
Settings	30
Settings for the inner draft shield	30
Settings for the outer draft shield	30
SmartSens	20
Switching Off	28
Switching On	28
<hr/>	
T	
Tare	53
Technical data	34
Transporting over long distances	23
Transporting over short distances	22
Transporting the balance	22
<hr/>	
U	
Units of measurement	52
Unpacking the balance	12
Unpacking the Balance	11

GWP® – Good Weighing Practice™

The global weighing guideline GWP® reduces risks associated with your weighing processes and helps to

- choose the appropriate balance
- reduce costs by optimizing testing procedures
- comply with the most common regulatory requirements

► www.mt.com/GWP

www.mt.com/comparators

For more information

Mettler-Toledo AG, Laboratory & Weighing Technologies

CH-8606 Greifensee, Switzerland

Tel. +41 (0)44 944 22 11

Fax +41 (0)44 944 30 60

www.mt.com

Subject to technical changes.
© Mettler-Toledo AG 08/2012
11780862B en

