

Operating instructions

METTLER TOLEDO LC-P45 Printer



METTLER TOLEDO

Overview

- 1 Introduction**
- 2 Startup procedure**
 - 1.1 What are the capabilities of the LC-P45 Printer → Page 3
 - 2.1 Cautionary notes → Page 4
 - 2.2 Inserting the batteries and paper, attachment, printing → Page 5
 - 2.3 Setting date and time → Page 6
- 3 Applications**
- 4 Operation**
 - 4.1 Selecting applications → Page 7
 - 4.1 Using the keypad → Page 10
 - 4.2 Configuring the printer in the menu → Page 10
 - 4.3 Entering values of variables (e.g. lot identification ID) → Page 12
 - 4.4 Selecting printer function → Page 13
- 5 Printer functions**
 - 5.1 Printing out weight values → Page 15
 - 5.2 Generating statistics of a weight series → Page 16
 - 5.3 Totalizing weight values → Page 17
 - 5.4 Multiplying (dividing) the weight by a factor → Page 18
 - 5.5 Recording the moisture determination with the LP16/LJ16 IR Dryer → Page 19
 - 5.6 Pipette test for calibrating volumetric dosing apparatus → Page 19
 - 5.7 Recording the processes with M-Pac application software packages → Page 21
 - 5.8 Checking a balance with a test weight → Page 22
 - 5.9 Calibrating (adjusting) a balance with a calibration weight → Page 23
- 6 Maintenance**
 - 6.1 Changing paper and ribbon → Page 24
 - 6.2 Maintenance, Service and Cleaning → Page 25
- 7 Malfunctions**
 - 7.1 Interpreting the error messages → Page 26
 - 7.2 Printer test → Page 28
- 8 Appendix**
 - 8.1 Accessories for GA45 Printer (paper, ribbon, etc.) → Page 28
 - 8.2 I/O interfaces → Page 29
 - 8.3 Attachment to METTLER TOLEDO instruments, additional hardware, available functions → Page 30
 - 8.4 Technical data → Page 33

1 Introduction

1.1 What are the capabilities of the LC-P45 Printer?

The LC-P45 is a versatile dot matrix printer with advanced print functions for normal paper. It can supplement the weight value with date, time and other data. It has two LocalCAN interfaces and one RS-232-C interface and is primarily suitable for attachment to METTLER TOLEDO balances and scales equipped with the standard software, but will also print out the records of the METTLER TOLEDO application software Pacs (M-Pacs) and of the LP16 and LJ16 METTLER TOLEDO Infrared Dryers.

The various print functions of the LC-P45 can be selected in the dialog mode (English, German, French, Spanish or Italian). The settings are stored in a fail-safe manner thanks to battery buffering.

- **Print weight**

The LC-P45 prints out the weight displayed on the balance directly.

- **Insertion of**
 - **Date and time**
 - **Lot identification (ID)**
 - **Balance identification**
 - **Current sample No.**

For users complying with quality management regulations such as GLP or GMP or for those who wish for a detailed record of a weighing. You can supplement the weighing result by automatically printing out any of the adjacent data.

- **Sample code**

The sample code, a comment for a more detailed definition of the weighing sample, is entered directly for every sample.

- **Generate statistics**



Without the need to purchase peripherals or software, the LC-P45 automatically generates statistics of the weight values of your sample series and calculates the most important statistical parameters.

- **Totalization**

The LC-P45 can also totalize weight values, thus calculating and documenting running totals. This function is especially useful when weighing in formulations.

- **Multiplication/division**

This function allows weight values to be multiplied or divided by any desired factors, Typical examples are calculating prices based on a price per unit weight or converting weights into volumes.

- **Check balance and calibrate**

A check on the accuracy of a balance by means of a test weight is fully documented. Likewise, adjustment of the balance by means of a calibration weight.

- **LP16/LJ16 Infrared Dryer**

Date, time and lot identification (ID) are automatically added to the record.

- **Pipette check**

This function enables pipettes and other volumetric measuring and dosing apparatus to be calibrated by a simple method which is also completely documented.

2 Startup procedure

2.1 Cautionary notes

For reasons of safety, the housing of the printer must not be opened by the user. If technical faults appear or if the printing unit or power line fuse has to be changed, please notify your responsible METTLER TOLEDO service.



- The LC-P45 Printer may be used only indoors and on no account in hazardous areas.
- The electronics of the LC-P45 Printer are protected against the ingress of splashing water and dust. However, as the printer housing is not tight the printer should not be used in the presence of liquids.
- Comply with cleaning instructions (see page 25), protect power plug against wet conditions.
- Never open the printer housing. Should you ever have problems with your printer, please contact your responsible METTLER TOLEDO dealer.

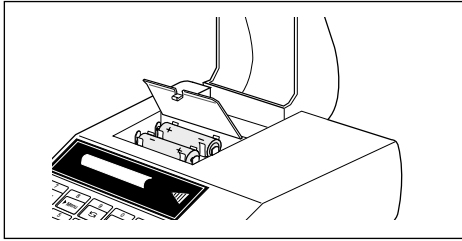

2.2 Inserting the batteries

Two batteries are provided and supply the clock and the memories for the variable settings of the printer when it is not connected to the power supply.

Please note: To avoid loss of any printer settings you may have made, attach the LC-P45 Printer to the power supply when changing the batteries.

- Lift up paper cover and pull paper backward out of the printing unit
- Open battery compartment and insert batteries

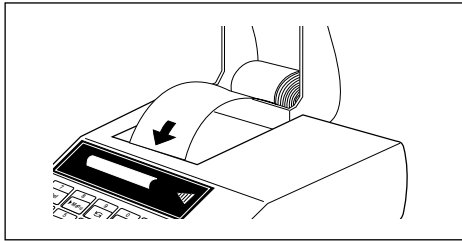

Inserting paper

- Feed paper through the slot in the printing unit in the direction of the arrow
- Switch on printer (toggle switch at right rear, the number of the software version will be printed out automatically)
- Press and hold  until sufficient paper has been fed in

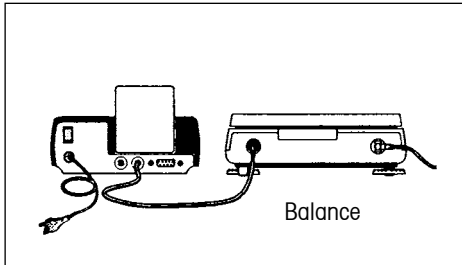

Attaching printer, printing

- Plug the cable supplied into the LC-P45 and the I/O data interface of a balance or instrument. The printer is now ready for operation!
-  Print out the weight value of the balance

If no printout appears: Set both devices to the factory setting! (The interface parameters are then matched. Green pilot lamp flashes, see page 26; available functions, see page 30)

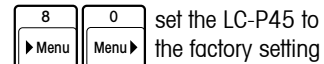

set the LC-P45 to the factory setting

2.3 Setting date and time

Setting or changing date and time to local time.

Date (EURO or US version)

- Start date definition

- Entry of the date, e.g.

- Concluding definition

23.01.97 (EURO format, day.month.year) or
1-23-97 (US format, month-day-year)

The input process can be checked in the
balance display

Correction of wrong entry



Please note: Separation of the numbers
with EURO by ".", with US by "-"

Time (24-hour format)

- Start time definition

- Entry of the current time, e.g. 13.46.05 (hours.minutes.seconds)

- Concluding definition

Note:  prints out date and time directly at all times

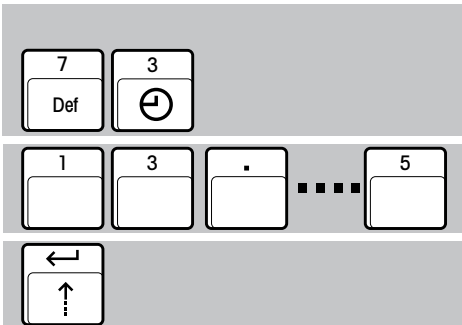
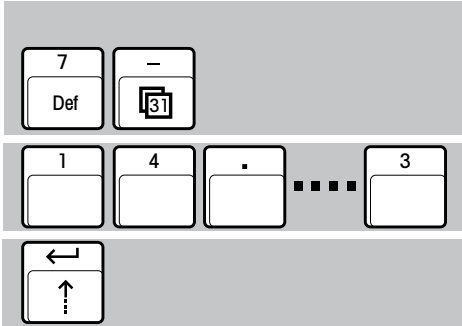

3 Selecting applications

Printing out weight values

Page 15

(1... 5) record header → p. 11)

3468.08 g

1

Print out weight by itself

ID 04-83-18.5
3468.08 g

2

Lot identification (ID) + weight

11.01.2000
ID 04-93-18.5
3468.08 g

3

Date + lot identification
+ weight

11.01.2000 14:53:32
ID 04-93-18.5
3468.08 g

4

Date + time + lot identification
+ weight

11.01.2000 14:53:32
3468.08 g

4

Date + time + weight (ID set to 0)

11.01.2000 14:53:32
ID 04-83-18.5
STANDARD V10.50.00
TYPE : PM6100
INR : 911375
3468.08 g

5

Complete documentation following
GLP (Good Laboratory Practice)

14 0.49 g
15 55.61 g
16 64.03 g
17 123.97 g

Current sample number
+ weight

Code 1500.08 g
8806-4.29

Weight + sample code (comment on
weighing)

Generating statistics of weight values

Page 16

11.01.2000 14:25:33
ID 52-88.6.31
1 99.5 g
2 101.5 g
3 103.5 g
4 100.5 g
5 102.4 g
6 104.5 g
n 6
 \bar{x} 101.98 g
s 1.87 g
srel 1.83 %
min. 99.5 g
max. 104.5 g
dif. 5.0 g
----- END -----

- Determine production homogeneity
- Demonstrate reproducibility of an experiment

Totalization

Page 17

11.01.2000
15:28:33
ID 71-00.6-34
1 206.55 g
2 3165.92 g
3 45.73 g
4 2.54 g
Sum 3420.74 g
----- END -----

- Simple formula weighing

Multiplying (dividing)

Page 18

Factor 3.5
 2.51 g
* 8.80

- Calculating prices
- Determining volume
- Determining density
- Weighing in any weight units
- Calculating weight of area or length (kg/m² or g/m)

**LP16/LJ16
IR Dryer**

Page 19

```

11.01.2000    15:28:33
ID            71-00.6-34
Time          5.0 Min
Temp          160 C
Mode          Timer
              0..-100%

    0.0M      11.010 g
    1.0M      -0.20 %
    2.0M      -1.36 %
    3.0M      -2.53 %
    4.0M      -3.18 %
    5.0M      -3.41 %

Time eff.     5.0 Min
              -3.41 %
              -0.377 g
----- END -----

```

- Documentation of a drying operation

Pipette check

Page 19

```

11.01.2000    11:15:50
ID            1128489
SNR:          1118000002
Factor        1.0032
Rounding      0.0001
              0.09844 g
1    98.7550 µl
              0.09870 g
2    99.0158 µl
              0.09876 g
3    99.0760 µl
              0.09882 g
4    99.1362 µl
n            4
x            98.99575 µl
s            0.16786 µl
srel         0.17 %
min.         98.7550 µl
max.         99.1362 µl
dif.         0.3812 µl
----- END -----

```

- Verification of volumetric dosing apparatus (pipettes, volumetric flasks, burettes, etc.)
- Generating statistics and calculating the most important statistical parameters

**METTLER M-Pacs
application software**

Page 21

```

-----
% FORMULA
-----
11.01.2000    13:29
*Target:     2500.00 g
*****
1*Comp       20.00 %
Weight       19.91 %
Weight       497.84 g
2*Comp       7.50 %
Weight       7.56 %
Weight       188.94 g
Total        686.80 g
Total        27.47 %
-----
Total        2501.10 g
Total        100.04 %
-----

```

- Documentation of the process sequence, e.g. of a formula weighing operation

**Checking balance
with test weight ***

Page 22

```
---- BALANCE TEST ----  
11.01.2000   14:31:57  
  
METTLER TOLEDO  
Balance  
Type:       PG503DR-S  
SNR:       1113000000  
  
Target:    200.000  
Actual:    200.005  
Diff:      0.005  
  
Internal test done  
  
Signature:  
  
.....  
----- END -----
```

- Documentation of the check following GLP and ISO 9001

**Calibrating
(adjusting) balance
with calibration weight ***

Page 23

```
-BALANCE CALIBRATION -  
11.01.2000   16:51:57  
  
METTLER TOLEDO  
Balance  
Type:       PG503DR-S  
SNR:       1113000000  
  
Int. calibration done  
  
Signature:  
  
.....  
----- END -----
```

- Documentation of the calibration following GLP and ISO 9001

* The printed records of the functions "Checking" and "Adjusting" appear in the respective national language only on connection to PR/SR balances. With all other balance models, English is used as the standard language.

4 Operation

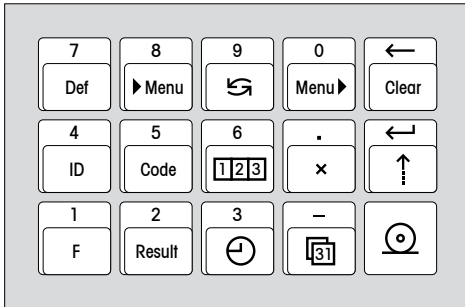

4.1 Using the keypad

Purpose of the keypad

1. Configuring the printer
2. Entry of variable values, e.g. lot identification (ID)
3. Selection of the printer function

Input mode

The printer functions are set in the dialog mode. The entries appear in the balance display and the LC-P45 prints them out as confirmation.

4.2 Configuring the printer in the menu

What is set and how?

The menu is used to configure the operational setting of the LC-P45:

- Set LC-P45 to factory setting
- Activate checking and calibration of the balance
- Select record header
- Select language of the dialog and record texts
- Select interface parameters





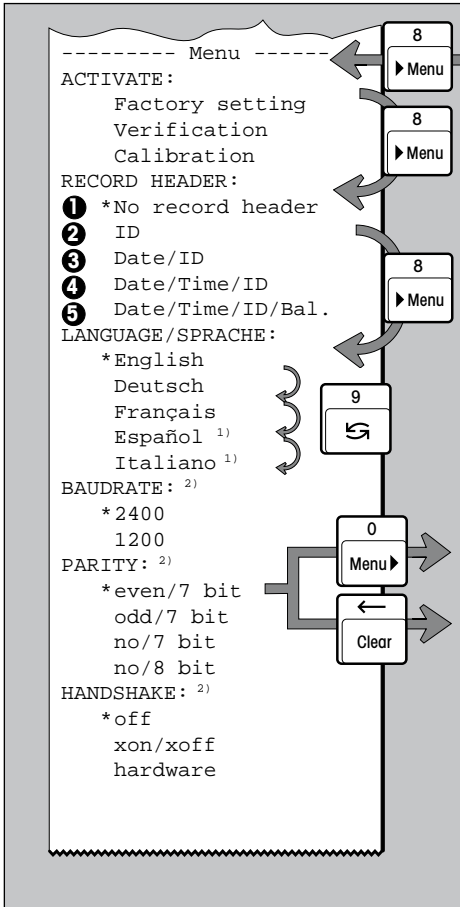

These three keys are used to enter the menu, choose the setting and store the selected setting.

Note: Variables are inputted directly. It is not necessary to enter the menu.







Configuring the printer

-  Entry into menu
-  Jump to next menu item, e.g. RECORD HEADER, LANGUAGE/SPRACHE...
-  Selection of the setting within a menu item, e.g. English, Deutsch...
 (1 ... 5 record header layout, see page 7)
-  Further settings if required
-  Quitting the menu **with** simultaneous storage of all selected settings
-  Quitting the menu **without** storage of the selected settings (abort)

Printing out the current menu settings

-   Printout of a list of the current settings
- 

Example of a setting































Entry into menu and changing the LC-P45 LANGUAGE/SPRACHE setting from English to Spanish or Italiano



Notes:

- * These settings are the factory settings; * marks the current setting after a change
- The menu settings are stored in a fail-safe manner (battery)
- ¹⁾ Either Español or Italiano
- ²⁾ I/O via LocalCAN interface: no setting necessary.

4.3 Entering values of variables

Variable value	Key sequence				Range of values
Time				Numeric values	 Hours.minutes.seconds (0.0.0 ... 23.59.59)
Date				Numeric values	 EURO: Day.month.year (1.1.00 ... 31.12.99) US: Month-day-year (1-1-00 ... 12-31-99)
Lot identification (ID)				Numeric values	 Number with max. 20 digits (0 ... 9 plus "." and "-") (0 removes the ID from the record)
Sample code (comment on individual weighing)				Numeric values	 Number with max. 10 digits (0 ... 9 plus "." and "-") [is not stored!]
Sample number start value				Numeric values	 1 ... 9 999 (0 removes the sample number from the record)
Factor for multiplication (division)				Numeric values	 0.000 001 ... 9 999 999
Rounding in multiplication				Numeric values	 0.05 : 2 decimal places, the 2nd rounded to 5 1.00 : 2 decimal places, both are = 0 0.001: 3 decimal places, the 3rd to the nearest 1
Number of line feeds after printout of weight or result				Numeric values	 0 ... 3

- Notes:**
- The input process can be checked in the balance display; correction of wrong entry with
 - The inputted values are stored in a fail-safe manner (exception: sample code)





4.4 Selecting printer function

- Entry into selection

Selection of function

```
* 1 = Print
  2 = Statistics
  3 = Totalization
  4 = Multiplication
  5 = IR Drying LP16/
    LJ16
  6 = Pipette check
```

On entry, a list of the available functions with their selection numbers are automatically printed out.



- **Printing** of weight values



or

- Generation of **statistics** of weight values



or

- **Totalization** of weight values

The input process can be checked in the balance display.
Correction of wrong entry



or



or

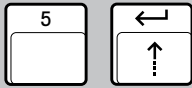

or



- **Multiplication** (division) of weight values by a factor

- Record of **drying operation** of LP16 and LJ16 IR Dryer

The selection of the printer function is stored in a fail-safe manner (battery)

- **Pipette test** for calibrating volumetric dosing apparatus

5 Printer functions

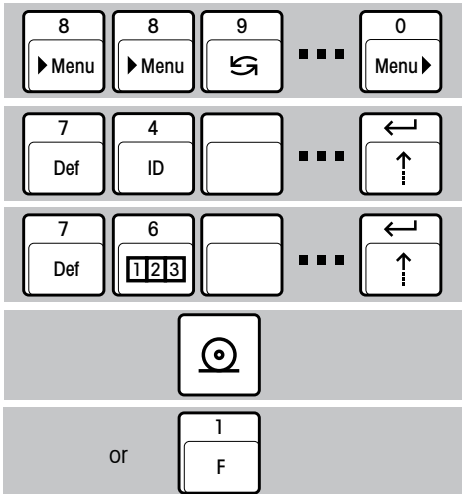
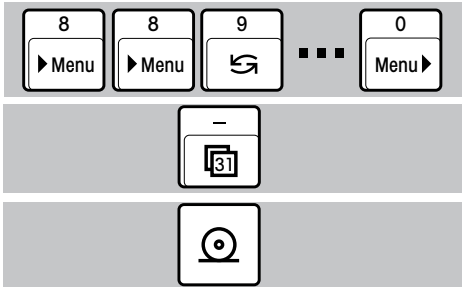

5.1 Printing out weight values

Printing with manual insertion of date and time

- Select "No record header" in the menu item RECORD HEADER (page 11)
- Print date + time
- Print weight

Set date and time

page 6

Printing with automatic insertion of date, time, lot identification (ID) and sample number, depending on requirements

- Select the record header according to requirements in the menu (e.g.date/time/ID; page 11)
- Enter according to requirements (page 12):
 - Lot identification (ID)
 - Sample number start value
- Print record header and weight automatically

- Print record header and current sample No. + weight automatically



Resets the sample No. to the start value at any time

5.2 Generating statistics of a weight series

- Select "Statistics" function (page 13)
- Select the record header in the menu (page 11)
- If required, enter lot identification (ID) (page 12)
- Load 1st sample and transfer weight value to the statistics
- Continue the sample series
- If desired, print out intermediate statistics (the sample counter is not reset)
- Continue the sample series
- Conclusion of the sample series with automatic printout of the overall statistics (the sample counter is reset, the statistics memory cleared)

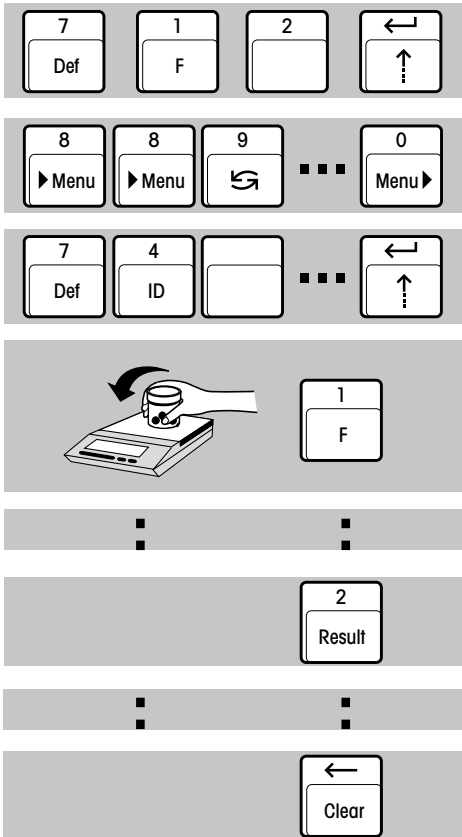

$$\bar{x} = \frac{1}{n} \sum_{i=1}^n x_i$$

$$s = \sqrt{\frac{1}{n-1} \sum |x_i - \bar{x}|^2}$$

$$s_{rel} = \frac{s}{\bar{x}} \cdot 100\%$$

min. = smallest value
 max. = largest value
 dif. = largest - smallest value
 max. number of samples = 999

5.3 Totalizing weight values

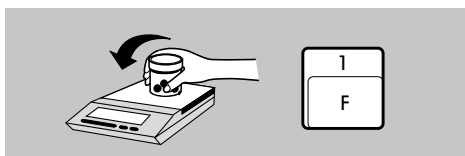
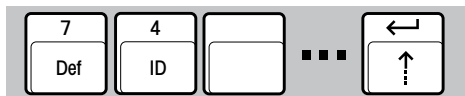

- Select function "Totalization" (page 13)
- Select record header in the menu (page 11)
- If required, enter lot identification (ID) (page 12)

- Load 1st sample and transfer weight value to totalization memory

max. number of samples = 9 999
max. total = 99 999 999 g

- Continue the sample series

- If need be, interrupt the sample series for automatic printout of the intermediate total (the sample counter is not reset)

- Continue the sample series

- Completion of the sample series with automatic printout of the total (the sample counter is reset, the totalization memory cleared)

5.4 Multiplying (dividing) the weight by a factor

7 Def	1 F	4	← ↑
8 ▶ Menu	8 ▶ Menu	9 ↻	0 Menu ▶
7 Def	4 ID		← ↑
7 Def	4 ID		← ↑
7 Def	4 ID		← ↑
7 Def	4 ID		← ↑
		1 F	
or	2 Result		

- Select function "Multiplication" (page 14)
- Select the record header in the menu (page 11)
- According to requirements, enter (page 12):
 - Lot identification (ID)
 - Sample number start value
 - Factor for multiplication (division)
 - Rounding in multiplication (division)
- Loading the weighing sample
- Automatic multiplication of the weight value by the preselected factor and printout of the **result together with multiplier and weight**
- Automatic multiplication by the preselected factor and printout of the **result alone**

5.5 Recording the moisture determination with LP16/LJ16 IR Dryer

The LC-P45 automatically inserts date, time and lot identification.

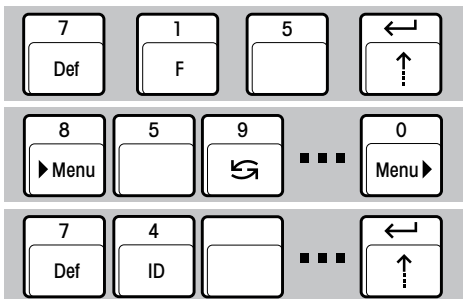

- Start drying

- Select function "IR Drying LP16/LJ16" (page 14)
- Select "Date/Time/ID" in menu item RECORD HEADER (page 11)
- If required, enter lot identification (ID) (page 12)
- Start drying operation according to instructions in the LP16/LJ16 operating instructions. The LC-P45 prints out the record

5.6 Pipette test for calibrating volumetric dosing apparatus

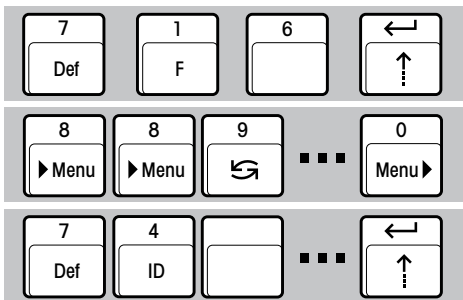

- Select function "Pipette check" (page 14)
- Select the record header in the menu (page 11)
- Enter pipette identification (ID) (page 12)

– When necessary enter sample number start value (page 12)

- Enter the factor z (ISO 8655) to calculate the volume from the mass (page 12). This factor is essentially a function of the water temperature and atmospheric pressure

- Enter the rounding off convention for the calculated result (page 12)

- Dosing the liquid and inclusion of the first volume in the statistics. The dosed volume is calculated automatically from the measured weight by multiplying it with the factor z. The weight and the calculated volume in μl , ($V = m \times z$) are printed out

- Continue the sample series

- If desired, print out intermediate statistics (the sample counter is not reset) (page 16)

- Continue the sample series

- Conclusion of the sample series with automatic printout of the overall statistics (the sample counter is reset, the statistics memory cleared) (page 16)

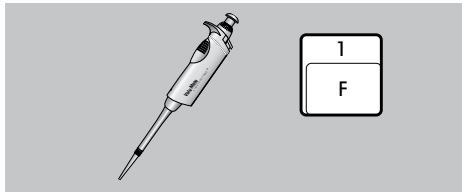
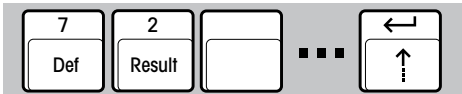
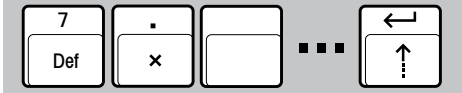

5.7 Recording the processes with M-Pac application software packages

The LC-P45 prints out the records of the M-Pacs, e.g. CountPac or LabPac.

- Select "No record header" in menu item RECORD HEADER (page 11)
- The LC-P45 is ready for work with M-Pacs.
It prints out their records.

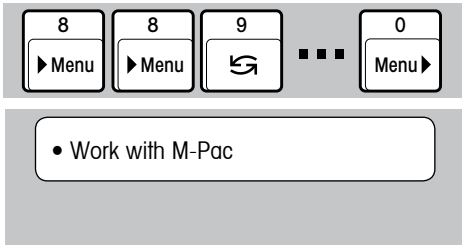

Note:  and  are inactive

5.8 Checking a balance with a test weight

- Selection and starting the check on the balance (page 11)

the menu section ACTIVATE is automatically printed out

The prompt for weight loading/removal is shown on the balance display. At the same time, the following record is printed out:

8
▶ Menu

9
↺

0
Menu ▶

ACTIVATE:
Factory setting
Verification
Calibration

*

Lo Ad



100002 g

* Minimum weight ≥ 900 in the last 3 places of the display.
Exemple: 9.38 g
 0.945 kg

<pre> ----- BALANCE TEST ----- 11.01.2000 14:31:57 METTLER TOLEDO Balance Type: PG503DR-S SNR: 1113000000 Target: 200.000 Actual: 200.001 Diff: 0.001 Internal test done Signature: ----- END ----- </pre>	date and time of verification	<pre> ----- BALANCE TEST ----- 11.01.2000 14:31:57 METTLER TOLEDO Balance Type: AB204 SNR: 1113000000 Weight ID: Target: Actual: 199.9800 g Diff: External test done Signature: ----- END ----- </pre>	date and time of verification
<pre> Balance Type: PG503DR-S SNR: 1113000000 </pre>	balance identification	<pre> Balance Type: AB204 SNR: 1113000000 </pre>	balance identification
<pre> Target: 200.000 Actual: 200.001 Diff: 0.001 </pre>	displayed weight value of the automatically tared balance difference between target and actual value	<pre> Weight ID: Target: Actual: 199.9800 g Diff: </pre>	identification of the test weight target value of the checking procedure displayed weight value of the automatically tared balance
<pre> Internal test done </pre>	signature of the tester	<pre> External test done </pre>	difference between target and actual value
<pre> Signature: </pre>	signature of the tester	<pre> Signature: </pre>	signature of the tester

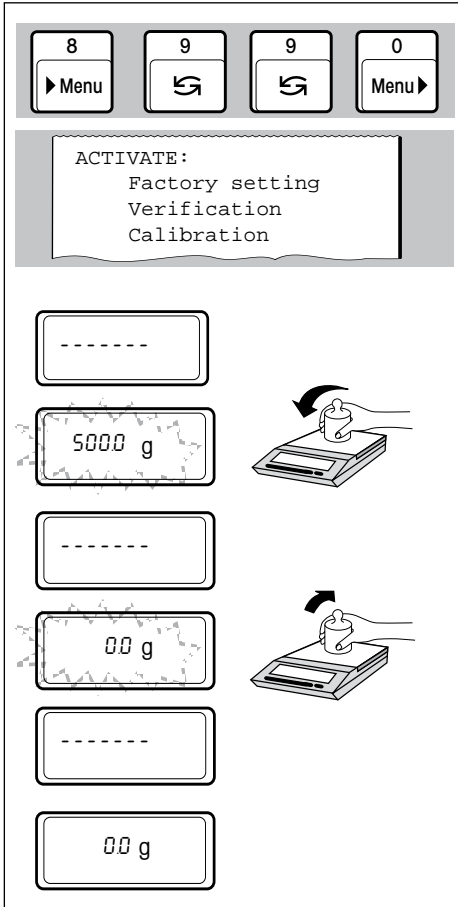

5.9 Calibrating (adjusting) a balance with a calibration weight

- Selection and starting the calibration procedure (page 11)

the menu section ACTIVATE is automatically printed out

The prompt for weight loading/removal is shown, as usual, on the balance display. With balances with an internal calibration weight, the automatic calibration routine is started. At the same time, the following record is printed out:

Adjusting with external adjustment weight

<pre> -BALANCE CALIBRATION-- 11.01.2000 14:31:57 METTLER TOLEDO Balance Type: PG503DR-S SNR: 1113000000 Weight ID: Weight: 500.000 g Ext. calibration done Signature: ----- END ----- </pre>	<p>date and time of verification</p> <p>balance identification</p> <p>identification number of the test weight</p> <p>target value of the adjustment procedure</p> <p>signature of the tester</p>
---	---

Adjusting with internal adjustment weight

<pre> -BALANCE CALIBRATION-- 11.01.2000 14:31:57 METTLER TOLEDO Balance Type: PG503DR-S SNR: 1113000000 Int. calibration done Signature: ----- END ----- </pre>	<p>date and time of verification</p> <p>balance identification</p> <p>signature of the tester</p>
---	---

6 Maintenance

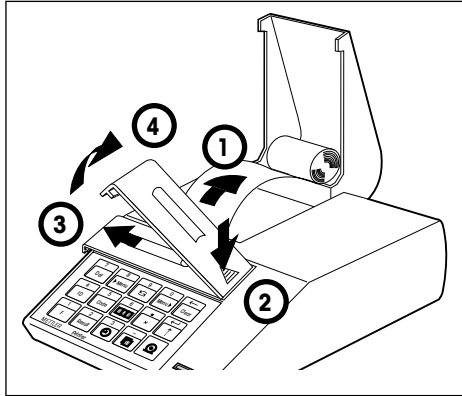

6.1 Changing paper and ribbon

Changing paper

- Insertion of a new roll of paper is described on page 5, commercially available, normal paper is used. Order number, see page 28.

Changing ribbon

Order number, see page 28.

- 1 Pull paper out of printing unit
- 2...4 Remove ribbon cover
- 5 Remove ribbon cartridge
- Insert new ribbon (if need be, take up slack with tensioning wheel) and refit ribbon cover
- Insert paper and feed through slit in the printing unit as far as it will go
- Press and hold  until sufficient paper has been fed in

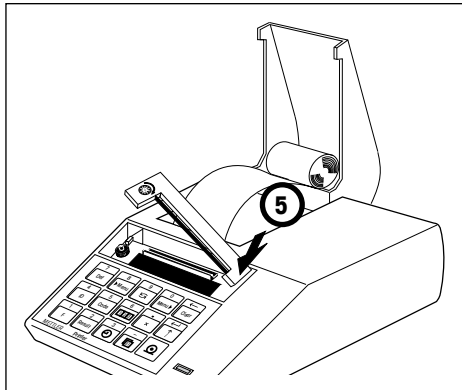

6.2 Maintenance, Service and Cleaning

Under normal ambient conditions, the LC-P45 Printer requires practically no maintenance thanks to its rugged construction. The METTLER TOLEDO service department is available should servicing be required. Please ask your responsible METTLER TOLEDO dealer for details.

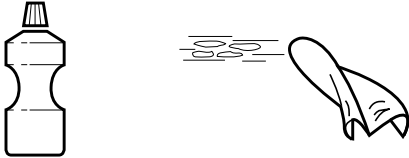

Cleaning

As the printer housing is made of top grade, resistant materials, all commercially available cleaning agents may be used.

7 Malfunctions

7.1 Interpreting the error messages

Malfunction/Message	Possible cause	Rectification
Printout unreadable	<ul style="list-style-type: none"> Ribbon worn/entangled Service life of printing unit at an end 	<ul style="list-style-type: none"> Change/tension ribbon Replace printing unit
Green pilot lamp does not light up	<ul style="list-style-type: none"> No power, fuse defective 	<ul style="list-style-type: none"> Switch on power switch, have fuse replaced by METTLER TOLEDO
Green pilot lamp flashes slowly	<ul style="list-style-type: none"> Balance waiting for stability/ cable not attached 	
Green pilot lamp flashes rapidly	<ul style="list-style-type: none"> Transmission error 	
<div style="border: 1px solid black; padding: 5px; text-align: center;"> ---- Interruption ---- </div>	<ul style="list-style-type: none"> Connection cable not attached or older balance (unidir. interface) 	<ul style="list-style-type: none"> Check handshake, initiate print command with PRINT key of balance
<div style="border: 1px solid black; padding: 5px; text-align: center;"> - Transmission error - </div>	<ul style="list-style-type: none"> Interface parameters of LC-P45 and balance do not match 	<ul style="list-style-type: none"> Set interface parameters
<div style="border: 1px solid black; padding: 5px; text-align: center;"> ----- ABORT ----- </div>	<ul style="list-style-type: none"> Calibration has been aborted 	<ul style="list-style-type: none"> Repeat calibration

----- Timeout -----

- Entry incomplete, menu not ended, balance has not sent any weight value in last 30 s
- Pause before completion of function must not be longer than 30 s, move balance to more stable location

- Battery discharged -

- Batteries for clock and settings discharged
- Replace batteries; message repeated approx. every 2 hours

----- Overflow -----

- Number of samples for multiplication exceeded

---- Input error ----

- Range of values exceeded
- Repeat entry

----- Unit error -----

- Different units in totalization, statistics or multiplication

ES

- Syntax error (error message of balance), balance does not understand LC-P45 instruction

EL

- Logistical error (error message of balance), balance can not execute LC-P45 instruction

7.2 Printer test

The LC-P45 is provided with a self-test which automatically prints out its character set. This allows easier recognition of a possible malfunction of the printing unit.

- Switch on LC-P45 and at the same time press and hold the feed key for a few seconds
- Terminate the printout by switching off the LC-P45

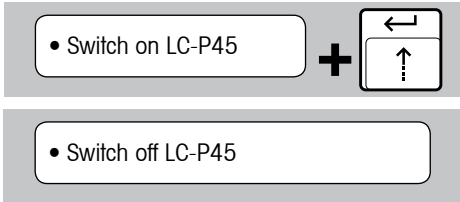

8 Appendix

8.1 Accessories for LC-P45 Printer

Accessory	Type/Order number	Standard equipment
Paper roll, set of 5	00072456	2 rolls
Ribbon cartridge, black, minimum order quantity 2	00065975	1 piece
Batteries, 2 x UM3/AA (1.5 V)	commercially available	2 piece
Connection cable LC-P45-balance/scale, LocalCAN, 1 m	LC-LC1 cable, 00229154	1 piece
Extension cable/connection cable LocalCAN, 2 m	LC-LC2 cable, 00229115	–
Extension cable/connection cable LocalCAN, 5 m	LC-LC5 cable, 00229116	–
T-socket for devices with only one LocalCAN socket	LC-LCT, 00229118	–
Connection cable LC-P45-balance, RS-232C, 1 m	RS9 (m)–RS9 (f) cable, 11101051	1 piece
Connection cable LC-P45-balance, RS-232-C (MiniMettler), 1.5 m	00229029	–
Spare printing unit (may be changed only by METTLER TOLEDO service)	–	–
Power line fuse 230 V (slow-blow 100 mA,250 V) + 115 V (slow-blow 200 mA,250 V) (may be changed only by METTLER TOLEDO service)	–	–

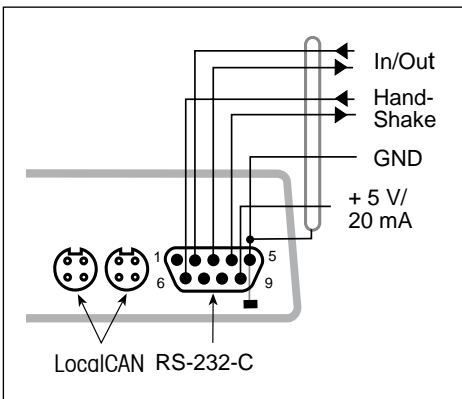

8.2 I/O interfaces

The LC-P45 has a LocalCAN and an RS-232-C interface for the attachment of METTLER TOLEDO instruments and peripherals.

One or other can be used, but if both are connected only the LocalCAN is active.

LocalCAN interface

- Bus interface with 2 4-pin looped sockets for the attachment of balances/scales/instruments and peripherals.
- No transmission parameters need be adapted.

RS-232-C interface

- 9-pin male connector (pin assignment as IBM laptop)
- Matching to other device (transmission parameters) in the menu; see page 11
- The handshake lines are active when "hardware" has been selected in menu item HANDSHAKE
- The standard cable 00229029 has no handshake lines

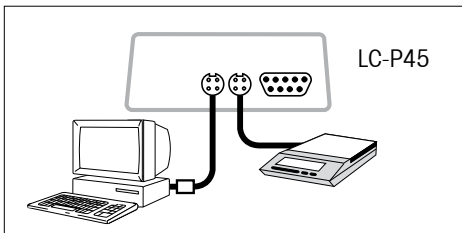

Connection example

A scale and a PC are attached to the LC-P45 via the LocalCAN bus.

Attachment to LC-P45				Available functions									
Attachment to balance or instrument	Remarks	Additional hardware		Printing weight	Printing record	Statistics, totalization, multiplication	Record header with time, date, ID	Calibrating documented	Checking of balance documented	Printing balance identification	Print command from LC-P45	Checking of key entries in balance display	
LP16/LJ16 PM-Pacs	↖ 1 ↗ 13 <input type="checkbox"/> ↖ 1 ↗ 12,13 <input type="checkbox"/>				●		●						
ID1	10 <input type="checkbox"/>	↖ 6 ↗	●		●	●			●			●	
ID3 with Option 082	10 <input type="checkbox"/>	↖ 6 ↗	●		●	●			●		●	●	
ID5 with Option 082/089	10 <input type="checkbox"/>	↖ 6 ↗	●		●	●			●		●	●	
IF with 504949 DT	13 <input type="checkbox"/>	↖ 6 ↗ ↖ 8 ↗	●		●	●			●		●	●	
DL18/21/25/35 FP62	13 <input type="checkbox"/> 13 <input type="checkbox"/>	↖ 7 ↗ ↖ 7 ↗		●									

Legend and general remarks to the attachment of the LC-P45 to METTLER TOLEDO instruments

Legend

Connection cable to LC-P45

- 1 ➤ 000229029 is standard
 - 2 ➤ Order number: 00042931
 - 3 ➤ 00059759 included in option
 - 4 ➤ Order number: 000229029
 - 5 ➤ Order number: 00047936
 - 6 ➤ Order number: 00504376
 - 7 ➤ Order number: 00017842
 - 8 ➤ Produce cable → page 29
 - 9 ➤ LC-LC1 cable is standard
 - RS ➤ RS9 (m) – RS9 (f) cable is standard
- ☐ = LocalCAN ○ = RS-232-C/CL

CL/RS-Interface converter

- ☑ CL249, Order number: 00059759



Adapter cable and hand switch

- ☑ Order number: 00047473
- ☑ Order number: 00042500

* Balance models earlier than 02.97

** Balance models after 02.97

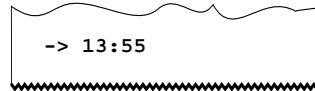

Continuation legend

- 10 Interface mode:
DIALOG MODE (standard setting).
If the terminal is in break condition, it has to be switched off and on again.
The LC-P45 can print maximally 24 characters a line, additional characters will be discarded.
- 12 Printout of Pac record only
- 13 Check of key entries via printout only, the balance display is inactive.
Example: Setting the time. After   the set time is printed out:



- 14 Documentation of calibration after balance software version 10.45.
- 15 For the AB, PB, SB, GB, CB and B balances and scales earlier than 02.97, the interface "LC-B Option" is required.

General remarks

- With  or  only stable weight values can be printed out; to print out unstable values, set the balance to "send all" and give the print command with its PRINT key.
- Do not set the balance to "send all" for statistics, totalization and multiplication.
- If the PRINT key of the balance is pressed, the weight will be printed out without record header

8.4 Technical data

Printer	
Printing unit	dot matrix printer 5x9 dots, 24-character line length, Epson/IBM character table No. 4
Printing speed	faster than 1 line per second
Ribbon cartridge	exchangeable, black
Paper roll	normal paper, 58 x dia. 51 mm, integrated in housing, commercial size
Printer functions	see page 3
Clock	date representation EURO or US format, leap year taken into account
Interface	LocalCAN and RS-232-C bidirectional
Transmission parameters LocalCAN	fixed adjustment
Transmission parameters RS-232-C	transmission rate 1200, 2400* baud, parity even*, odd, no character length 7 bit*, 8 bit
Handshake	Bidirectional handshake: off*, xon/xoff, hardware
Printer buffer	128 characters
	* = factory setting

Designed test conditions

Power supply voltage, Frequency	115 V oder 230 V, admissible fluctuations -20%+15%, 50/60 Hz
Current consumption	140 mA or 70 mA
Height	4000 m
Temperature range	5...40 °C
Humidity	max. relative humidity 80% for temperatures to max. 31 °C linear decreasing to 50% at 40 °C
Installation category	II
Pollution degree	2
Dimensions / weight	W x D x H = 157 x 210 x 85 mm / net 1.5 kg (incl. paper roll)

**To protect your METTLER TOLEDO product's future:
METTLER TOLEDO service assures the quality, measuring accuracy and preservation
of value of all METTLER TOLEDO products for years to come.
Please send for full details about our attractive terms of service.
Thank you.**



Subject to technical changes and to the availability
of the accessories supplied with the instruments.

© Mettler-Toledo AG 2009 705108D Printed in Switzerland 0909/2.12

Mettler-Toledo AG, Laboratory & Weighing Technologies, CH-8606 Greifensee, Switzerland
Phone +41-44-944 22 11, Fax +41-44-944 30 60, Internet: <http://www.mt.com>