

REINFORCING STEEL SCHEDULE				
USE ASTM A615 GRADE 60 MIN. REINFORCING STEEL				
ITEM	QTY	SIZE	LENGTH	WGT
ST1	240	#4	3'-0	480
ST2	16	#4	4'-0	43
ST3	40	#4	19'-6	521
ST4	120	#6	8'-0	1441

7541 NOTES:

- PLACE LOAD CELL BASE PLATES IN POSITION (10 PLACES) ADD RECEIVER AND 1/4" OF SHIMS AT BOTTOM. ADD RECEIVER WITH "O" RING AT TOP. "O" RING MUST BE GREASED WITH LOAD CELL LUBRICANT. INSERT LOCATING TOOLS IN RECEIVERS.
- SET MODULE WITH RECEIVERS ON LOCATING TOOLS STARTING WITH FIRST MODULE. SET TERMINAL MODULE SECOND AND SET MIDDLE MODULES LAST ON TRANSFER BARS. PULL MODULES TOGETHER AS SHOWN IN DETAIL D (NO GAP). MAINTAIN EQUAL DISTANCE TO PIT WALL AT EACH END.
- TO ALIGN BEAMS LONGITUDINALLY, STAINLESS STEEL SHIMS ARE REQUIRED AT EACH SIDE OF TRANSFER BARS (SEE E-E). SHIM EQUALLY EACH SIDE TO PREVENT LATERAL MOVEMENT BETWEEN BEAMS. SHIMS ARE INCLUDED IN TA202142 K.O.P.
- THE TWO SETS OF TIE RODS SHOULD BE ADJUSTED AND LOCKED TO MAINTAIN THE APPROXIMATE 3/4" GAP BETWEEN BEAMS AND TO ALLOW ALL MODULES TO MOVE LONGITUDINALLY TOGETHER. NO GAP IS REQUIRED BETWEEN 1" WELDED BAR AND 2" POWER CELL TRANSFER BAR. SEE DETAIL D.
- USING BASE PLATE AND END WALL BUMPER BRACKET HOLES AS TEMPLATES, DRILL AND INSTALL EXPANSION BOLTS (46 PLACES). LOCATE AT CENTER OF HOLE.
- SET LONGITUDINAL BUMPER (1-1/2 BOLT) GAP 1/16 TO 1/8 MAX. SET SIDE BUMPER (1 1/4 BOLT) TO 1/16 GAP. LOCKNUT BUMPER BOLTS IN PLACE.
- IMPORTANT: BOLTS AND NUTS MUST BE TORQUED TO SPEC USING TURN OF NUT METHOD OR TORQUE VALUE. TURN-OF-NUT TIGHTENING REQUIRES THE BOLT BE TIGHTENED ADDITIONALLY ONE HALF TURN AFTER SNUG TIGHT. TORQUE VALUES ARE 180 FT.LBS FOR THE 3/4 EXPANSION BOLT, 400 FT.LBS. FOR THE BUMPER BOLTS, AND 400 FT.LBS. TIE ROD NUTS AGAINST TIE ROD NUTS.
- THE DECK CHANNELS SERVE BOTH AS A COPING AND AS A FORM FOR THE DECK. SECURE AND SPACE THE CHANNELS FROM THE PIT COPING BY WELDING SPACER BARS OR ANGLES (BY OTHERS) TO THE PIT COPING AND DECK CHANNELS. (NBS HANDBOOK 44, PARAGRAPH UR2, REQUIRES CLEARANCE AT BOTTOM EDGE OF PLATFORM TO BE GREATER THAN AT TOP EDGE OF PLATFORM. METTLER TOLEDO RECOMMENDS AN ADDITIONAL 3/8" SPACE AT BOTTOM EDGE.) WELD THE DECK CHANNELS TO THE MAIN BEAMS. SEE DETAIL C, F-F, AND G-G. PLACE CORRUGATED DECKING (28 GAUGE MIN) ON TOP OF THE BEAMS. PLACE THE REINFORCING BARS AND MANHOLE IN POSITION IN ACCORDANCE WITH THE DRAWING. USE 4000 PSI CONCRETE AT 28 DAY AGE. IF SUBJECT TO FREEZING, USE 5% TO 7% AIR ENTRAINMENT. REINFORCING STEEL AND CONCRETE SHALL BE PLACED ACCORDING TO THE AMERICAN CONCRETE INSTITUTE CODE. BURN OFF THE SPACER WELDS AND REMOVE SHORING AFTER THE DECK HAS CURED.
- AFTER CONCRETE IS CURED, RECHECK BUMPER GAPS AND TACK WELD IN PLACE. SEE DETAIL C.
- INSTALL LOAD CELLS: NOMINAL MODULE HEIGHT IS BASED ON 1/4" SHIMS AT BOTTOM RECEIVERS (DETAIL D). USE 1/16" AND 1/8" SHIMS AS REQUIRED TO BRING MODULES TO SAME HEIGHT AND APPROXIMATE SAME INITIAL. MAXIMUM THICKNESS OF SHIMS TOP, OR BOTTOM, IS 3/8". THE INTERIOR BEARING SURFACE OF ALL LOAD CELL RECEIVERS (BOTH TOP AND BOTTOM) MUST BE GREASED WITH LOAD CELL LUBRICANT DURING LOAD CELL INSTALLATION.
- MOUNT J-BOXES TO MIDDLE MODULES.
- CORRUGATED DECKING, SHORING, REBAR, AND CONCRETE TO BE FURNISHED BY OTHERS.

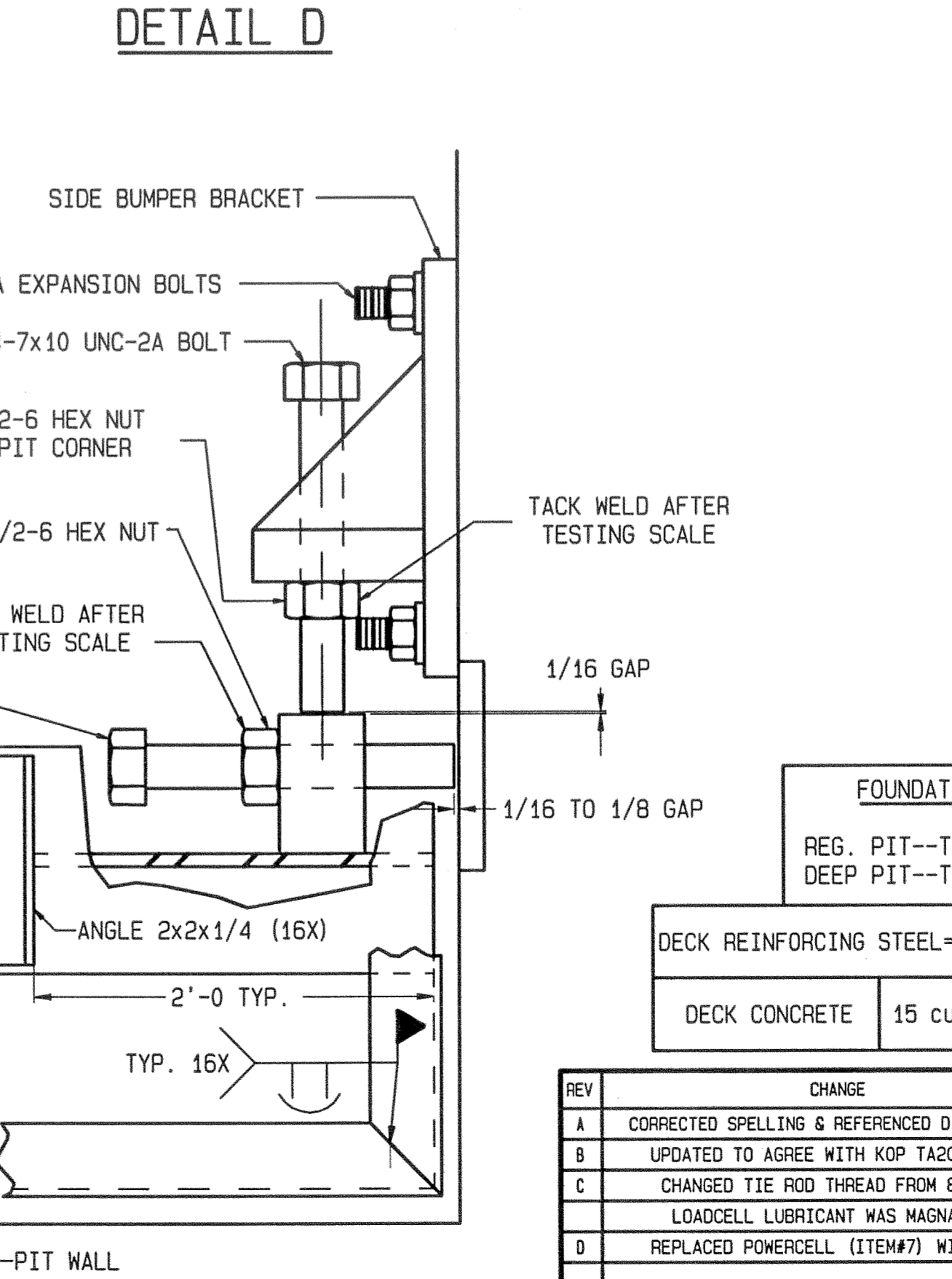
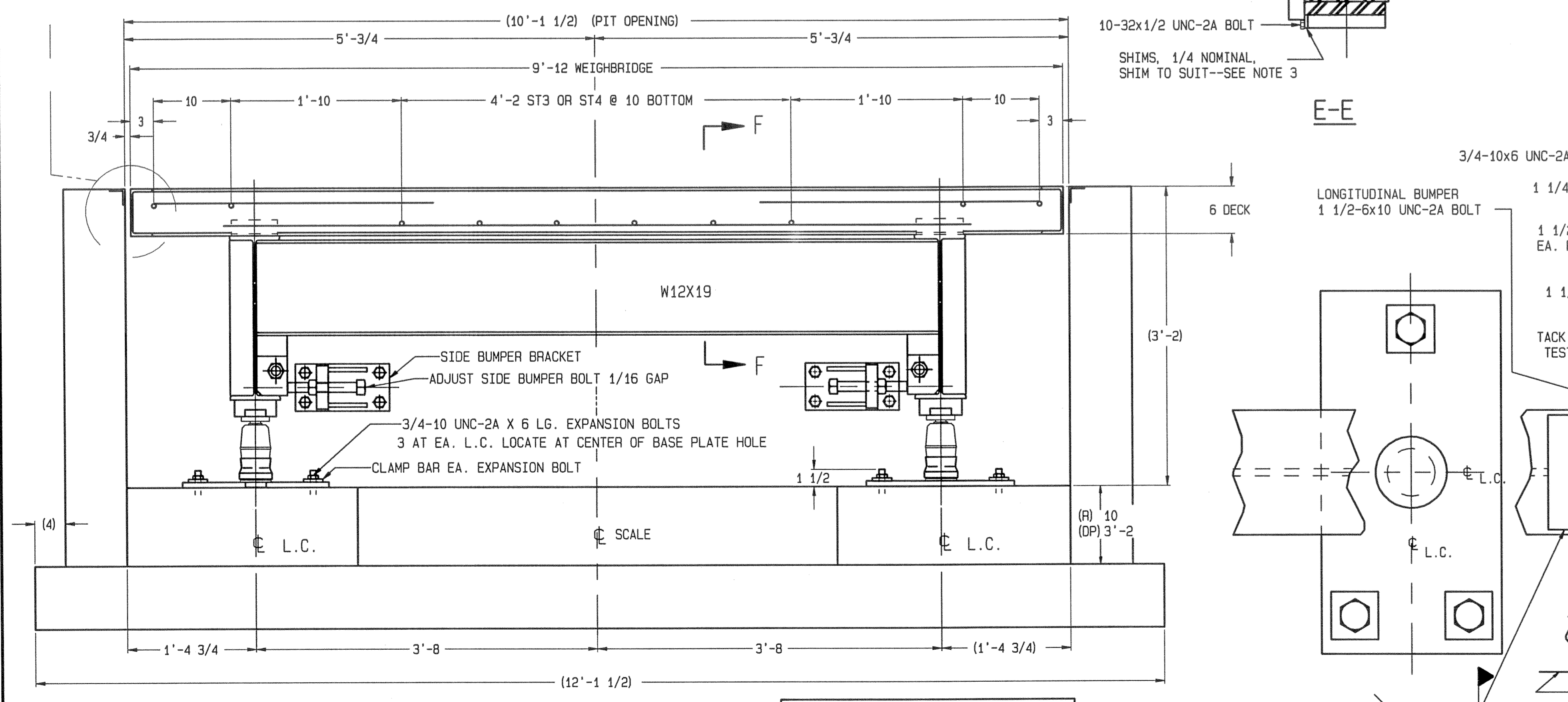
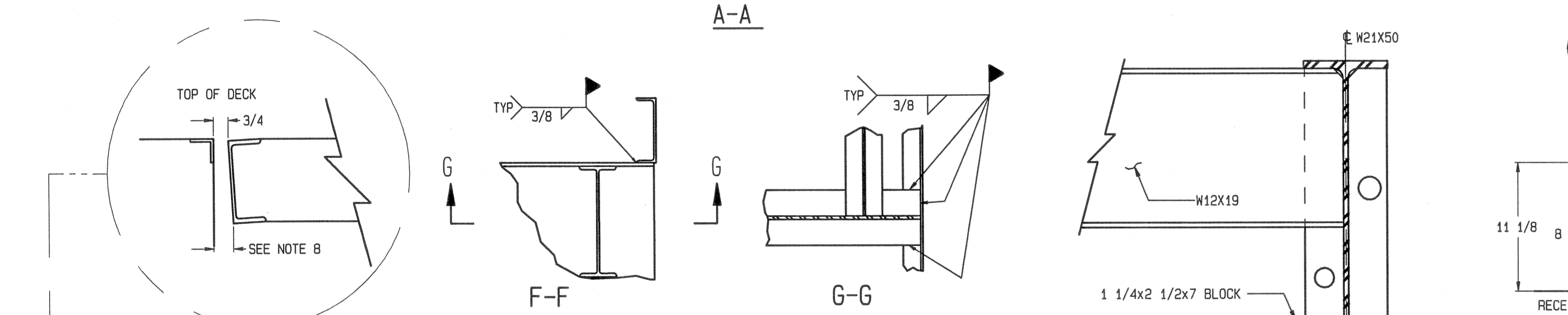
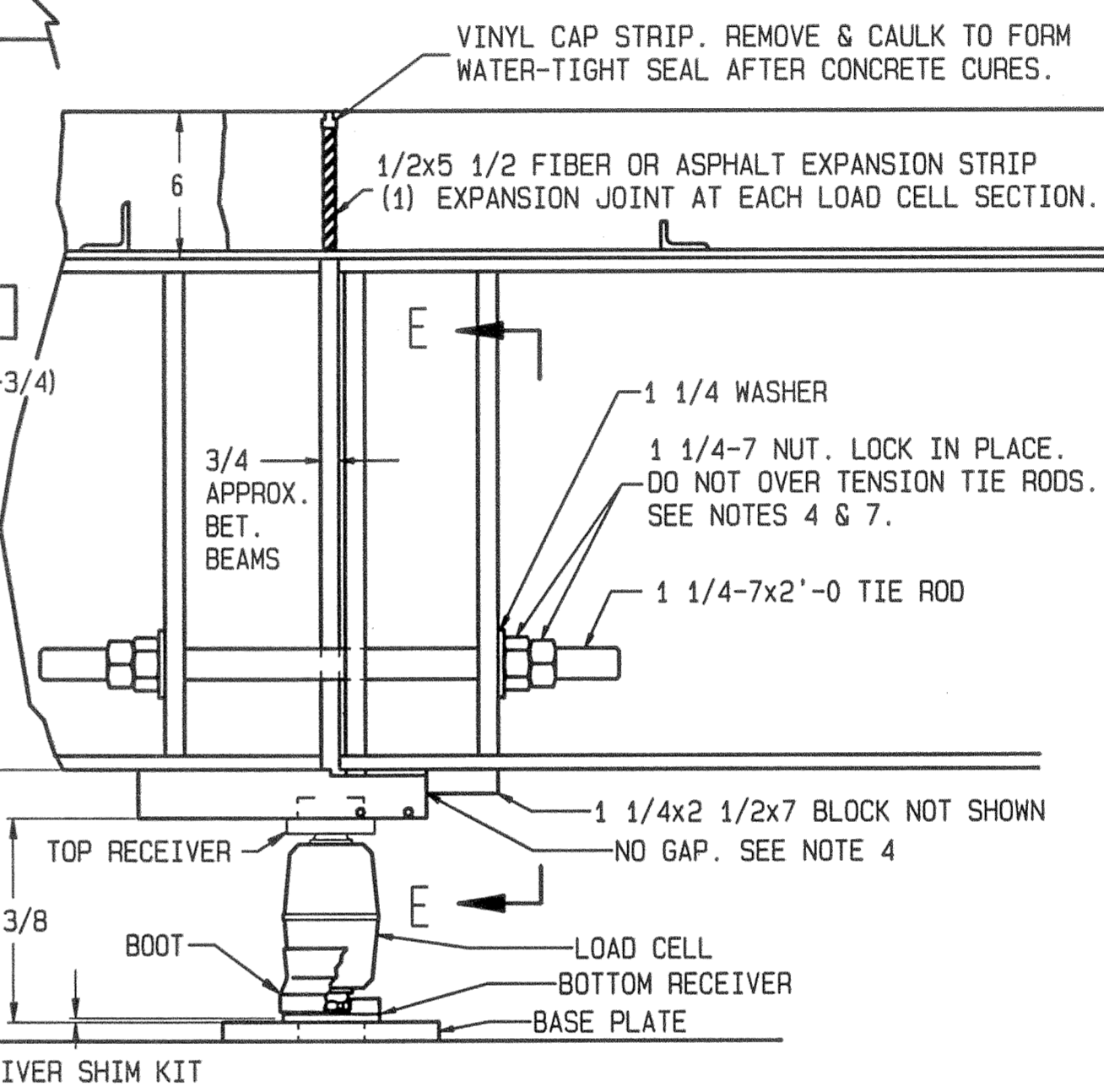
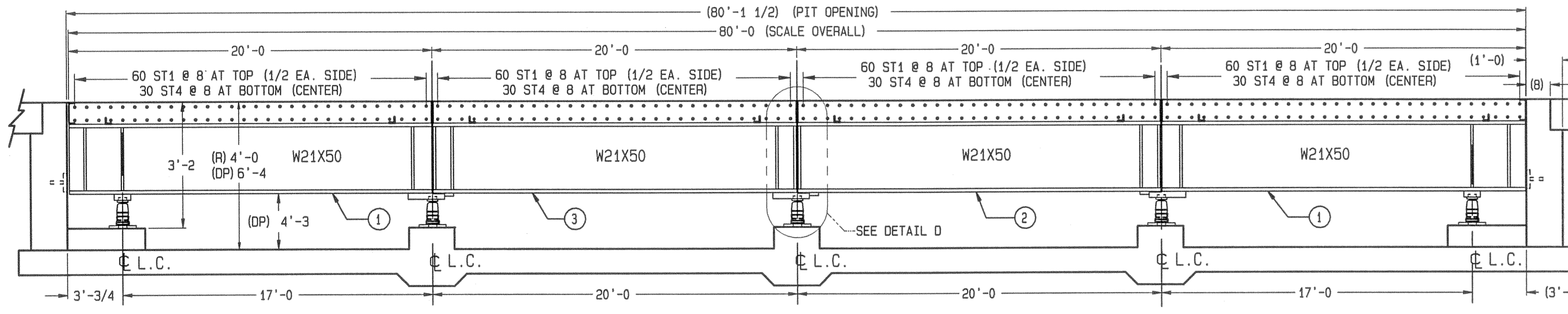

REV	CHANGE	BY	DATE	SCALE	DESCRIPTION
A	CORRECTED SPELLING & REFERENCED DIMENSIONS	YLS	1/31/94	DATE 4/14/93	
B	UPDATED TO AGREE WITH KOP TA202142-E	SEH	7/6/95	OPN YLS APPD JLB	
C	CHANGED TIE ROD THREAD FROM 8 TO 7				
	LOADCELL LUBRICANT WAS MAGNALUBE	DGR	7/31/96		
D	REPLACED POWERCELL (ITEM#7) WITH MTX	HEB	04/04/08		

ITEM	QTY	PART NUMBER	DESCRIPTION
8	2	09260001	MANHOLE
7	10	*15476400A	MTX LOAD CELL 25mt CAPACITY
6	1	TC100497-4	WIRING KOP
5	1	TA202142-4	HARDWARE KOP
4	1	TB201616-04	CHANNEL FRAME ASSEMBLY
3	1	TC201601-00E	20'X10' MIDDLE MODULE W/TRANSFER BAR
2	1	TC200796-00D	20' X 10' MIDDLE MODULE
1	2	TC200794-00B	20' X 10' END MODULE

FOUNDATIONS	
REG. PIT--TC201540	
DEEP PIT--TC201636	

DECK REINFORCING STEEL=2485 LBS	
DECK CONCRETE	15 cu. yds.

FRACTIONAL	DECIMAL	ANGULAR
+1/32	.XX ±.02	±.5°
	.XX ±.005	

NOTE: (R) DIMENSION IS FOR THE REGULAR PIT. (DP) DIMENSION IS FOR THE DEEP PIT.

**METTLER TOLEDO**

TC202357 REV D