

Designed for Fast Production

The ICS4_5 and ICS685



Designed to Fit

Are you looking for a compact scale that fits into your industrial environment? If so, the new rugged aluminum die-cast scales are the right choice for you. Benefit from a wide range of applications, designs, various integration options and user-friendly handling.



Highest Performance

Increase your productivity by minimizing overfilling, avoiding underfilling and detecting incorrect parts. The ICS compact scales feature high performance weighing technology delivering accurate results fast. Benefit from up to four scale connections extending the capacity range and resulting in more accurate piece counting.



Easy Operation

Weighing, counting or checkweighing are labor intensive applications. Having various different people involved in a process often leads to mistakes which cost you time and money. The new smart scales are simple to operate, feature intuitive straight-forward menus, color display and user prompting in various languages.



Broad Connectivity

Profit from fast data handling and efficient printing as well as from various options for seamless integration into existing systems. Manage data in the scale's internal database, comfortably monitor data on a PC or export it with a USB stick.



Speed Up Your Production Processes

The compact scale line: ICS425 – ICS435 – ICS445 – ICS465 and ICS685 offers you seamless integration into your production process as your scale can be individually configured for fast and precise operations—exactly according to your particular needs.

The scales feature different applications used in the manufacturing industries:

- Simple weighing
- Counting
- Totalizing
- Checkweighing
- Portioning, Filling
- Classifying

Terminals

	ICS425	ICS435	ICS445	ICS465	ICS685
Application/Features	Basic weighing, Average weighing / Date & Time and Printing Counting, Alibi Memory*, Softkeys and User Prompting, Over / Under Checkweighing, Totalizing, Database (up to 100 articles for ICS445 and ICS465), Database Software Filling, Classifying, User Management, Database (up to 5000 articles), Transaction Memory*				
Dimension & Type	248.5 x 164 x 78 mm Diecast aluminum				
Display	LCD liquid crystal graphical display with backlighting				color TFT display (320 x 240 pixel)
					with colorWeight®
Character height	Default layout mode = 19 mm, 3-line info mode = 15 mm, Big Fond 25 mm				25 mm / 17 mm
Languages	English, German, French, Italian, Spanish, Chinese, Portuguese, Japanese				
Keypad	Tactile-touch membrane keypad (PET), scratch-resistant material				
Numeric keypad	No	Yes	No	Yes	Alphanumeric keypad
Net / Shipping Weight	2 kg / 2.5 kg				
Mains connection	100 – 240 V / 50 – 60 Hz / 300 mA, Power cord approx. 2.5 m				
Optional internal battery	12 VDC / 2.5 A 1 strain gauge weighing cell continuous operation ~ 22 h (less with installed options, e.g. WLAN) 1 MonoBloc weighing cell continuous operation ~ 14 h (less with installed options, e.g. WLAN) Life time: 500 to 1000 charging/discharging cycles				
Ingress Protection	AC-Version: IP65; Exchangeable battery version: IP5x				
Temperature range	Class III –10 to 40 °C (Strain gauge) Class II 10 to 30 °C (MonoBloc®)				
Humidity	Max. rel. humidity 85 % for temperatures up to 40 °C				
Data interfaces	1 x Standard RS232 1 x Optional				1 x Standard RS232 3 x Optional
	Choose from the following interfaces: RS232, RS422/485, USB device, USB host, Ethernet, WLAN, Digital I/O, digital or analog 2nd scale				
Connectable platforms	1 scale can be connected; all analog & SICS & IDNet platforms (except F-cell, AWU cell, GD16-17, PIK)		2 scales can be connected; all analog & SICS & IDNet platforms (except F-cell, AWU cell, GD16-17, PIK)		4 scales can be connected; all analog & SICS & IDNet platforms (except F-cell, AWU cell, GD16-17, PIK) (2 analog max.)
Analog scale connection	Impedance: $\geq 87.5 \Omega$ (means 1 x 350 Ω ; 4 x 350 Ω), Excitation: 3.3 VDC, Sensitivity: 2 to 3 mV/V Max. Resolution: 7500e (OIML), 300 000d (non approvable), Min. verification interval: 0.264 $\mu\text{V/e}$				
Approvals	OIML, NTEP, CE, CSA, various local approvals				
Accessories	Cable with plugs for offered interfaces, Stand (height 330 mm), Wall bracket, Printers, Cover for terminal, Battery charger, Auxiliary display, Relay module Power supply conversion kit to operate on 9-28 VDC				

*Up to 300'000 entries. Optional for ICS445 and ICS465. Standard for ICS685.

Terminal Dimensions

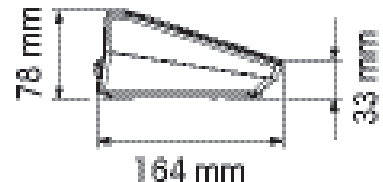
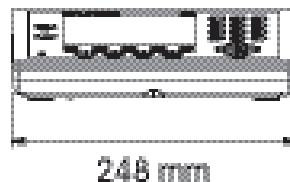

Compact Scales

For highest precision: MonoBloc® technology

- Approved resolution up to 61 000e OIML
- Non-approved resolution up to 610 000d
- Fully Automated Calibration Technology (FACT) function calibrates the scale according to temperature changes and increases accuracy of weighing results

ICS425k-/ICS435k-/ICS445k-/ICS465k-/ICS685k-								
Platform (Single Range)	0.6XS/f	3XS/f	6XS/f	6SM/f	15LA/f	35LA/f	6SM/f	15LA/f
Capacity [g]	610	3100	6100	6100	15100	35100	6100	15100
Readability Standard [d]	0.001	0.01	0.01	0.1	0.1	0.1	0.1	0.1
Platform (Delta Range)	0.6XS/DR	3XS/DR	6XS/DR	6SM/DR	15LA/DR	35LA/DR	-	-
Capacity [g]	120/610	600/3100	1200/6100	1200/6100	3000/15100	7000/35100	-	-
Readability Standard [d]	0.001 / 0.01	0.01 / 0.1	0.01 / 0.1	0.1 / 1	0.1 / 1	0.1 / 1	-	-
Approved Readability [d]/[e]	0.001 / 0.01	0.01 / 0.1	0.01 / 0.1	0.1 / 1	0.1 / 1	0.1 / 1	0.2 / 0.2	0.5 / 0.5
Verification Interval [e] = [d]	e=10d	e=10d	e=10d	e=10d	e=10d	e=10d	e=d	e=d
Repeatability (sd) [g]	0.001	0.01	0.01	0.1	0.1	0.1	0.1	0.1
Linearity [g]	0.002	0.02	0.02	0.2	0.2	0.2	0.2	0.2
Ingress Protection (std./opt.)	IP5x/-	IP5x/IP65	IP5x/IP65	IP5x/IP65	IP5x/IP65	IP5x/IP65	IP5x/IP65	IP5x/IP65
Weight of scale [kg]	6.4	5.7	5.7	5.7	9	9	5.7	9

■ alternate configuration

For best performance: Strain gauge technology

- Approved resolution of 1 x 6000e OIML
- Non-approved resolution up to 60 000d

ICS425d-/ICS435d-/ICS445d-/ICS465d-/ICS685d-					
Capacity and Platform Size	3SM/f	6SM/f	15LA/f	35LA/f	PBD655/t
Capacity [kg]	3	6	15	35	for higher capacities from 6 - 600 kg, 1 x 6000e OIML see brochure PBD655 Digital Weighing Platform
Approved readability OIML [g]	0.5	1	2	5	
Optional readability [g]	0.05	0.1	0.2	0.5	
Repeatability (sd) [g]	0.05	0.1	0.2	0.5	
Linearity [g]	0.1	0.2	0.5	1	
Ingress Protection: Standard/Optional	IP5x/IP65	IP5x/IP65	IP5x/IP65	IP5x/IP65	IP65
Weight of scale [kg]	5.5	5.5	7.7	7.7	-

Compact Scale with Small Platform

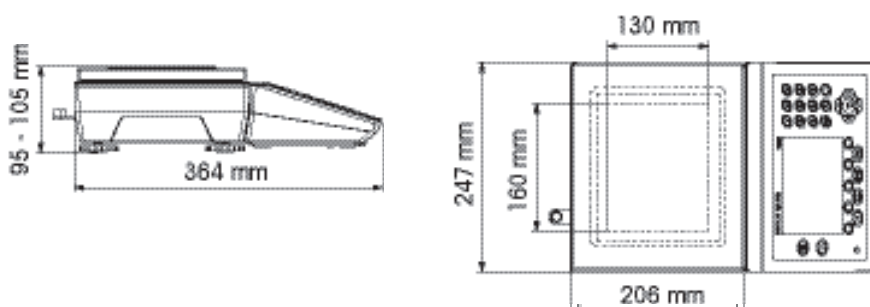

XS size platform: 160 x 130 mm
 SM size platform: 240 x 200 mm
 LA size platform: 350 x 240 mm

Compact Scale with Large Platform

The terminal is tightly mounted with two screws (wrench size 10 mm) on the platform.

The terminal can be mounted on the longer and the shorter side of the platform or just placed next to the platform or mounted to the wall with optional wall bracket.

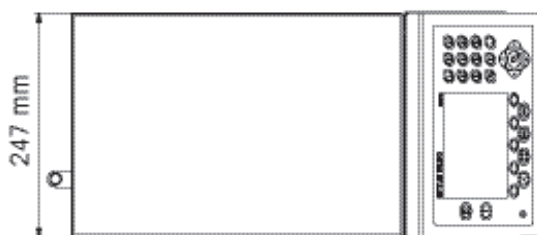
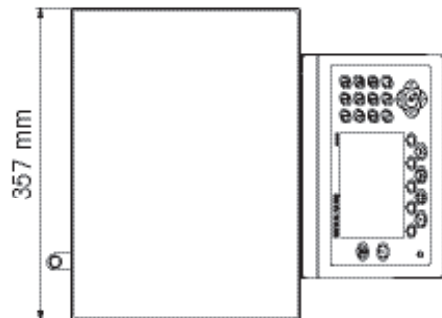
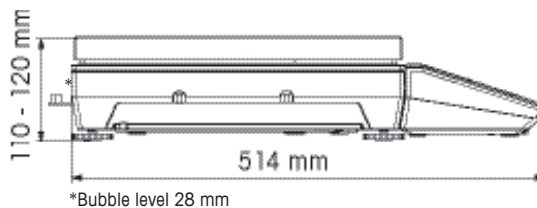
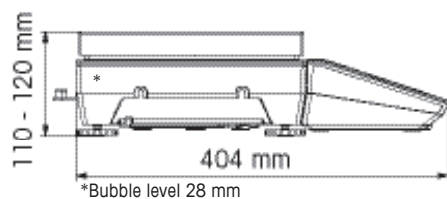

Scale ICS__5k-0.6XS MonoBloc with Windshield

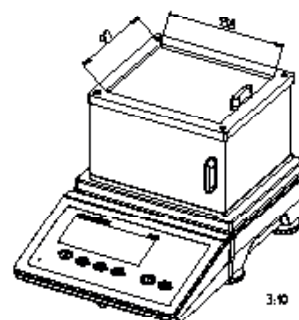
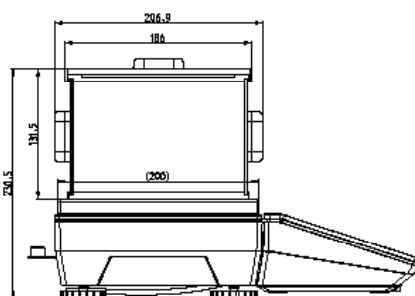
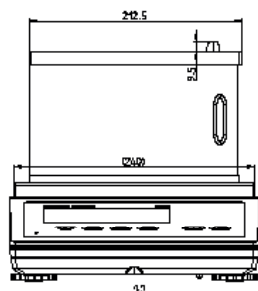

Accessories

- Cable with plugs for the offered interfaces
- Column (height 330 mm)
- Wall bracket
- Windshield*
- Printers
- Protective cover for terminal
- Battery charger
- Auxiliary display
- Relay module
- Power supply conversion kit to operate on 9-28 Volt

* ...0.6XS standard; ...3XS, ...6XS optional

Mettler-Toledo AG
 CH-8606 Greifensee
 Switzerland
 Phone +41 44 944 22 11
 Fax +41 44 944 30 60



ISO/IEC17025 Accredited
 Service Organizations
 Results, not promises.

www.mt.com

For more information

Subject to technical changes
 © 02/2015 Mettler-Toledo AG
 Printed in Switzerland
 MarCom Industrial
 MTSI 22023426A

METTLER TOLEDO Service