

Excellence Plus Micro Balances

XP56/XP26 Models – Part 1

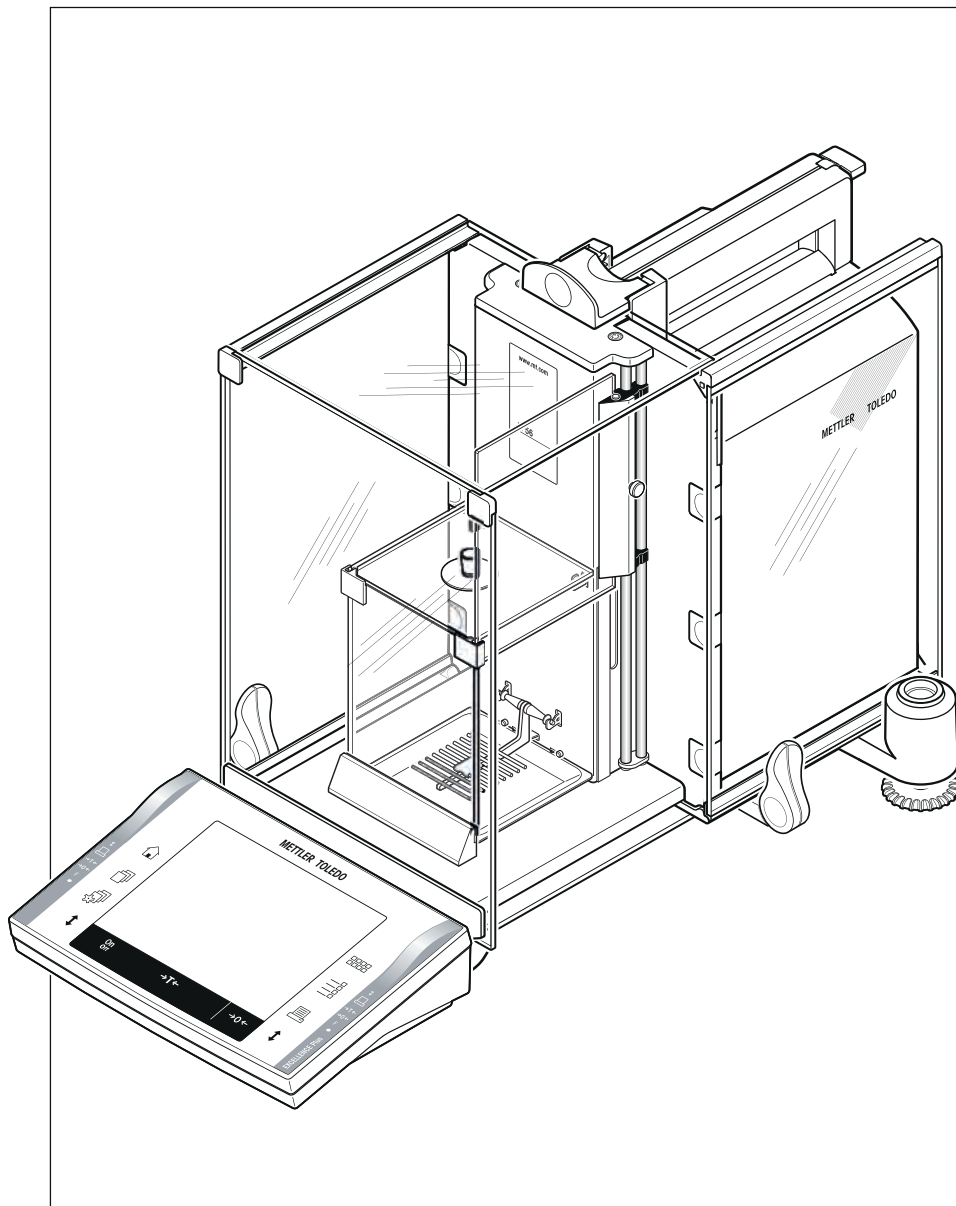

METTLER TOLEDO

Table of Contents

1	Introduction		5
	1.1	Symbols and presentations used	6
2	Safety Information		7
	2.1	Explanation of warnings and symbols	7
	2.2	Product specific safety notes	7
3	Overview of XP56/XP26 Micro Balances		9
4	Installation and Putting into Operation		10
	4.1	Unpacking	10
	4.2	Scope of delivery	12
	4.3	Location	12
	4.4	Assembling the balance	13
	4.4.1	Inner draft shield	13
	4.4.2	Outer draft shield	15
	4.5	Connecting the balance	17
	4.6	Operating of the outer draft shield and the inner draft shield	18
	4.6.1	Outer draft shield	18
	4.6.2	Inner draft shield	19
	4.7	Setting the reading angle and positioning the terminal	19
	4.7.1	Setting the reading angle	19
	4.7.2	Remove terminal and place close to the balance	19
	4.8	Transporting the balance	20
	4.8.1	Transporting over short distances	20
	4.8.2	Transporting over long distances	21
	4.9	Below-the-balance weighing	24
	4.10	Installing the ErgoClip	24
	4.11	Installing the SmartGrid cover	25
5	First Steps		26
	5.1	Switching on / off	26
	5.2	Leveling the balance	26
6	Maintenance		28
	6.1	Cleaning	28
	6.2	Disposal	28
7	Technical Data		29
	7.1	General data	29
	7.2	Explanatory notes for the METTLER TOLEDO AC adapter	29
	7.3	Model-specific data	30
	7.4	Dimensions	33
	7.5	Interfaces	34
	7.5.1	Specifications of RS232C	34
	7.5.2	Specifications of "Aux" connection	34
8	Accessories and Spare Parts		35
	8.1	Accessories	35

	8.2	Spare parts	44
9	Appendix		46
	9.1	MT-SICS interface commands and functions	46
	9.2	Procedure for certified balances	46
	Index		48

1 Introduction

Thank you for choosing a METTLER TOLEDO balance.

The balances of the XP line combine a large number of weighing and adjustment possibilities with exceptionally convenient operation.

In this chapter you will be given basic information about your balance. Please read right through this chapter carefully even if you already have experience with METTLER TOLEDO balances. Please pay special attention to the safety warnings!

The different models have different characteristics regarding equipment and performance. Special notes in the text indicate where this makes a difference to operation.

The XP line comprises a range of balances which differ from each other in relation to their weighing range and resolution.

The following features are common to all models of the XP lines:

- Glass draft shield with motorized drive and inner glass draft shield for precise weighing even in unstable environments.
- Fully automatic adjustment "ProFACT" using internal weights.
- Built-in level sensor, illuminated level indicator and Leveling Assistant for fast and easy leveling.
- Built-in applications for normal weighing, statistics, formulation, piece counting, percent weighing, density, differential weighing and LabX Client.
- Integral RS232C interface.
- Slot for second interface (optional).
- Touch-sensitive graphics terminal ("Touch screen") with color display.
- Two programmable sensors for hands-off operation ("SmartSens") to speed up frequently recurring tasks.

A brief word about standards, guidelines, and methods of quality assurance: The balances comply with usual standards and guidelines. They support standard procedures, specifications, working methods, and reports according to **GLP (Good Laboratory Practice)**. In this connection, records of working procedures and adjustments become very important; for this purpose we recommend you to use a printer from the METTLER TOLEDO range, since these are optimally adapted to your balance. The balances conform to the applicable standards and guidelines and possess a EC declaration of conformity. METTLER TOLEDO is certified as manufacturer according to ISO 9001 and ISO 14001.

The operating instructions for the XP balances consist of 3 separate documents, whose contents are listed below.

Part 1, this document

Contents

- Introduction
- Safety information
- Installation and putting into operation
- Leveling the balance
- Cleaning and service
- Technical data
- Accessories
- Spare parts
- Interface commands and MT-SICS functions

Part 2, separate document

Contents: Terminal, System, and Applications

- Basic principles for using the terminal and the firmware
- System settings
- User-specific settings
- Applications
- Firmware (Software) updates
- Error and status messages
- Conversion table for weight units
- Recommended printer settings

Part 3, separate document

Contents: Adjustments, and Tests

- Adjustments
- Tests

Finding more information

► www.mt.com/excellence

Firmware version

The operating instructions are based on the initially installed terminal firmware (software) version V 4.00.

1.1 Symbols and presentations used

The following conventions apply to the operating instructions: part 1, part 2 and part 3.

Key and button designations are indicated by a picture or text in square brackets (e.g.  or [On/Off]).



This symbol indicates press key briefly (less than 1.5 s).



This symbol indicates press and hold key down (longer than 1.5 s).

These symbols indicate an instruction:

- prerequisites
- 1 steps
- 2 ...
- ⇒ results

2 Safety Information

2.1 Explanation of warnings and symbols

Safety notes are indicated by signal words and warning symbols and contain warnings and information about safety issues. Ignoring safety notes can lead to personal injury, damage to the instrument, malfunctions and erroneous results.

Signal words

WARNING	for a hazardous situation with medium risk, possibly resulting in severe injuries or death if not avoided.
CAUTION	for a hazardous situation with low risk, resulting in damage to the device or the property or in loss of data or minor or medium injuries if not avoided.
Attention	(no symbol) for important information about the product.
Note	(no symbol) for useful information about the product.

Warning symbols



General hazard



Electrical shock

Mandatory signs



Gloves must be worn

2.2 Product specific safety notes

Intended use

Your balance is used for weighing. Use the balance exclusively for this purpose. Any other type of use and operation beyond the limits of technical specifications without written consent from Mettler-Toledo AG, is considered as not intended.



It is not permitted to use the instrument in explosive atmosphere of gases, steam, fog, dust and flammable dust (hazardous environments).

General safety information

Your instrument meets the state of the art technology and complies with all recognized safety rules, however, certain hazards may arise in extraneous circumstances. Do not open the housing of the instrument: It does not contain any parts which can be maintained, repaired or replaced by the user. If you ever have problems with your instrument, contact your authorized METTLER TOLEDO dealer or service representative.

Always operate and use your balance only in accordance with the operating instructions part 1, part 2 and part 3.

The instructions for setting up your new balance must be strictly observed.

If the instrument is not used according to the manufacturer's operating instructions (part 1, part 2 and part 3), protection of the instrument may be impaired.

Staff safety

In order to use the instrument, you must have read and understood the operating instructions. Keep the operating instructions for further reference.

Never make any modifications to the instrument and use only original spare parts and optional equipment from METTLER TOLEDO.

Safety notes



WARNING

Risk of electric shock

Use only the original universal AC adapter delivered with your balance, and check that the voltage printed on it is the same as your local power supply voltage. Only plug the adapter into a socket which is grounded.



CAUTION

Damage to the balance

- a) Only use indoors in dry locations.
 - b) Do not use pointed objects to operate the keyboard!
The balance is of a very sturdy design, but is still a precision instrument. It must be handled with care.
 - c) Do not open the balance:
The balance contains no user-serviceable parts. In the event of problems, please contact a METTLER TOLEDO representative.
 - d) Only use METTLER TOLEDO original accessories and peripheral devices for the balance. These are specifically designed for the balance.
-

3 Overview of XP56/XP26 Micro Balances

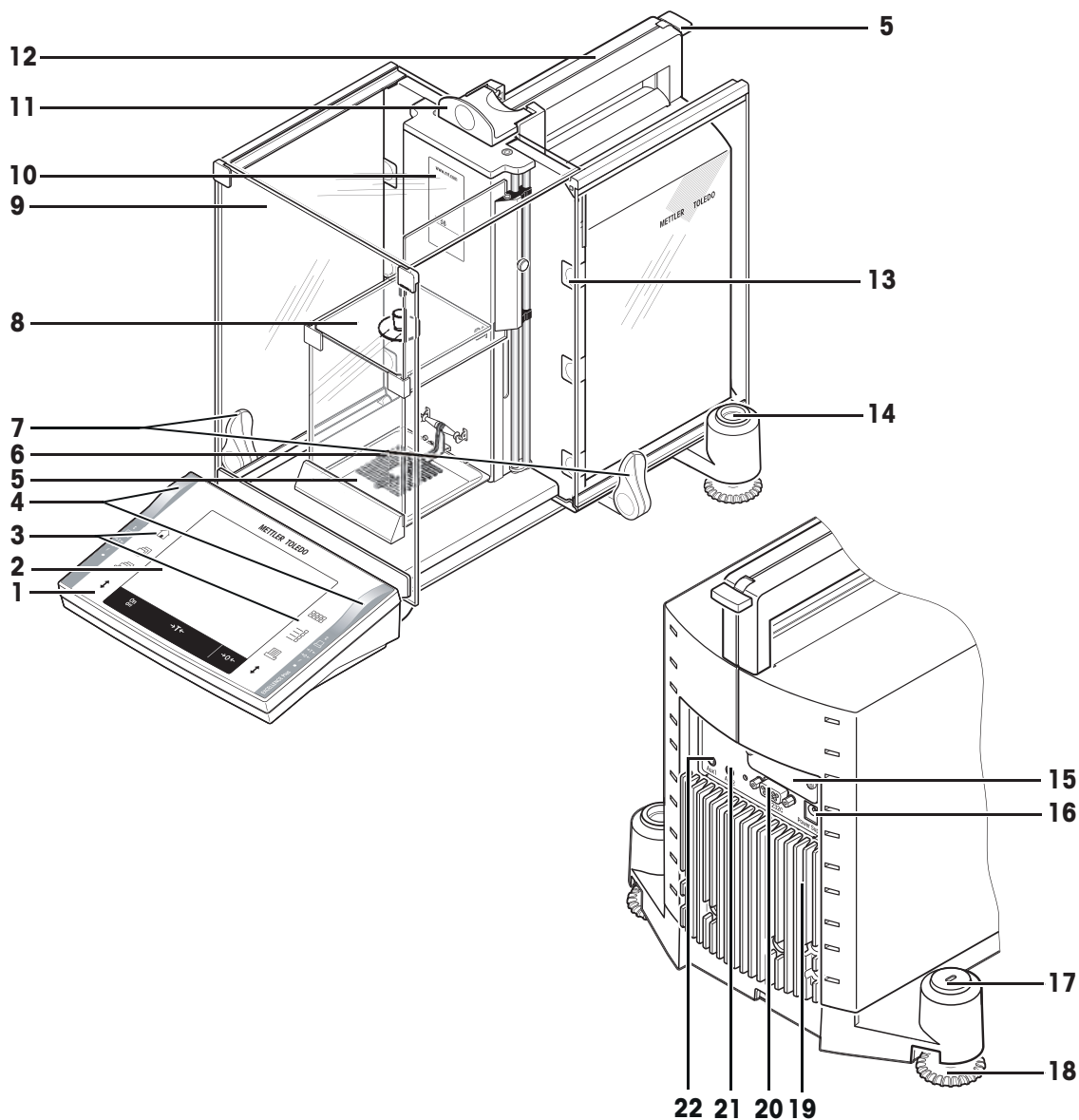

Overview

1	Terminal (details see Operating Instructions – Part 2)	2	Display (Touch-sensitive "Touch screen")
3	Operating keys	4	SmartSens sensors
5	Drip tray	6	SmartGrid weighing pan
7	Handle/Coupling element for the operation of the outer draft-shield doors	8	Inner glass draft shield
9	Outer glass draft shield	10	Type name
11	Handle for operation of the outer draft-shield top door	12	Guide for top door of draft shield and handle for transport
13	Removable clips for feeding cables or hoses	14	Level indicator / Level sensor
15	Slot for second interface (optional)	16	Socket for AC adapter
17	Fastening point for anti-theft device	18	Foot screw
19	Cooling element (based on model)	20	RS232C serial interface
21	Aux 2 (connection for "ErgoSens", hand- or foot-switch)	22	Aux 1 (connection for "ErgoSens", hand- or foot-switch)

4 Installation and Putting into Operation

This chapter explains how to unpack your new balance, and how to set it up and prepare it for operation. When you have carried out the steps described in this chapter, your balance is ready for operation.

4.1 Unpacking

- 1 Open the outer packaging box.
- 2 Remove it from the packaging the Unpacking and packing instructions.
- 3 Lift the cardboard box (1) out of the packaging.

Overview

- 1 Cardboard box with 2 sets (see next 2 pictures)
 - 2 Top packing cushion
 - 3 Set with inner draft shield, drip tray, and SmartGrid micro
 - 4 Balance
 - 5 Lifting strap
 - 6 Terminal
- Note**
The terminal is connected to the balance by a cable!
- 7 Bottom packing cushion

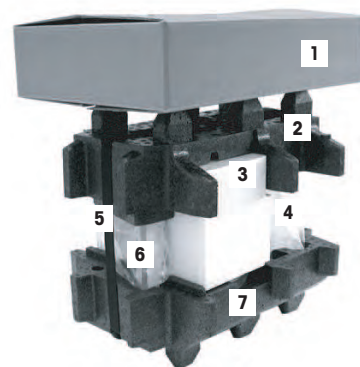

- Take out the Operating Instructions and other documents (8) that explain the further procedure for unpacking and assembling your balance.



- 1 Pull out set (9) with AC adapter, power supply cable, tweezers, and the set containing ErgoClip basket micro and SmartGrid cover micro.
- 2 Pull out set (10) with outer draft shield doors and terminal support.



Set with:

- ErgoClip basket micro
 - Support (11)
 - Basket (12)
- SmartGrid cover micro (13).

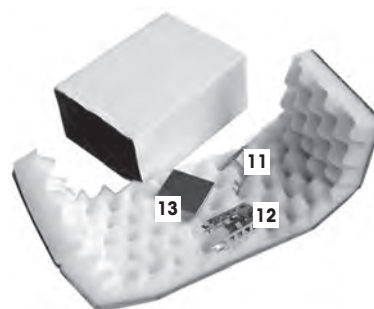

Use the lifting strap to lift the balance out of the packaging carton.

- 1 Unfasten lifting strap (5).
- 2 Remove top packing cushion (2).

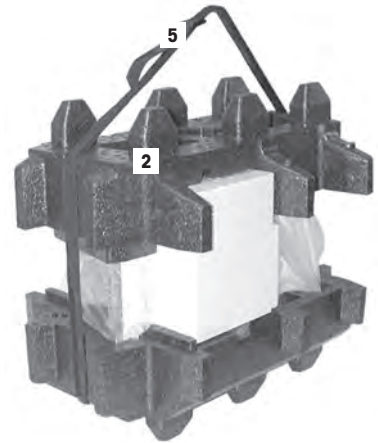

- Pull out set (3) with inner draft shield etc.



- Carefully pull the terminal out of the bottom packing cushion and remove the protective cover.

Note

The terminal is connected to the balance by a cable, so only pull the terminal just far enough out of the packing cushion to remove the protective cover.



- 1 Place the terminal on the front of the balance.
- 2 Hold the balance by the guide or handle, hold the terminal firmly with your other hand, and pull the balance and terminal together out of the bottom packing cushion.



- 1 Place the balance with the terminal in the place where the balance will be used for weighing.
- 2 Remove the cover from the balance.



Note

Please keep all parts of the packaging. This packaging guarantees best possible protection of your balance for transportation.

Also see

- Transporting the balance (page 20)

4.2 Scope of delivery

The standard scope of delivery contains the following items:

- Balance with terminal
 - RS232C interface
 - Slot for second interface (optional)
 - Feedthroughs for below-the-balance weighing and for antitheft device
- Set with outer draft shield and terminal support
- Set with inner draft shield, drip tray and SmartGrid micro
- Set with:
 - Ergo Clip basket micro with support
 - SmartGrid cover micro (attachment for SmartGrid)
- Protective cover for the terminal
- AC adapter with country-specific power cable
- Tweezers
- Cleaning brush
- Production certificate
- CE declaration of conformity
- Operating instructions part 1 (this document), part 2 and part 3
- Instructions for unpacking, re-packing, and setting up

4.3 Location

An optimal location will ensure accurate and reliable operation of the balance. The surface must be able to safely take the weight of the balance when fully loaded. The following local conditions must be observed:

Note

If the balance is not horizontal at the outset, it must be leveled during commissioning.

- The balance must only be used indoors and up to a maximum altitude of 4,000 m above sea level.
- Before switching on the balance, wait until all parts are at room temperature (+5 to 40°C).
The humidity must be between 10% and 80% non-condensing.
- The power plug must be accessible at all times.
- Firm, horizontal and vibration-free location.
- Avoid direct sunlight.
- No excessive temperature fluctuations.
- No strong drafts.

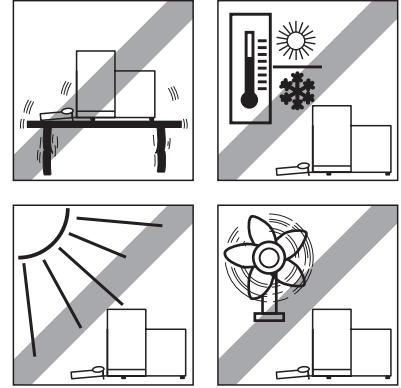

Further information can be found in Weighing the Right Way.

4.4 Assembling the balance

4.4.1 Inner draft shield

- 1 Insert the front glass (1) of the inner draft shield.
- 2 Ensure the glass is centered and pushed in as far as the stop.

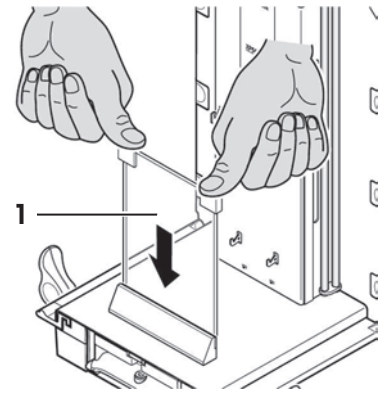

- 1 Insert the drip tray (1) from the side under the upper 2 pins. The notches must be positioned by the springs.
- 2 Insert the SmartGrid (2) from above.
- 3 Check that the SmartGrid is correctly hooked in on both sides.

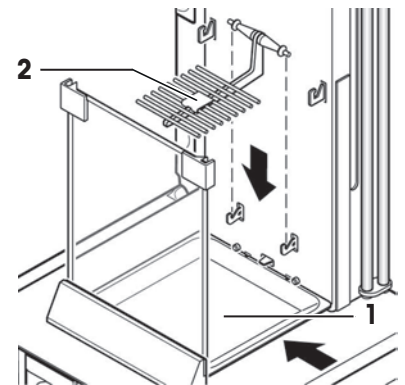

- 1 Insert the side window (1) of the inner draft shield.
At an angle of approximately 45 degrees to the final position, place the 2 black clips on the back guide shaft.
- 2 Push the window up until you can swivel it in over the front glass.

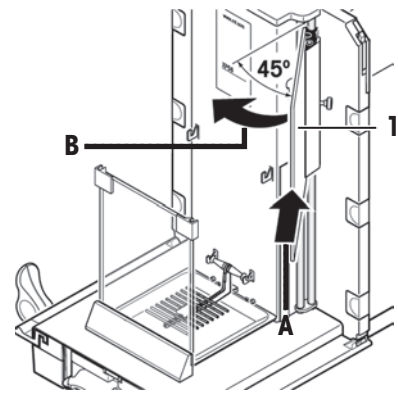

- 1 Insert the window (1) of the inner draft shield into the guide of the front glass and lower it to the floor.
- 2 The window must run easily.
- 3 Press the coupling pins (2) toward the inside.
- 4 Now insert the window on the other side of the inner draft shield.
The procedure is the same.

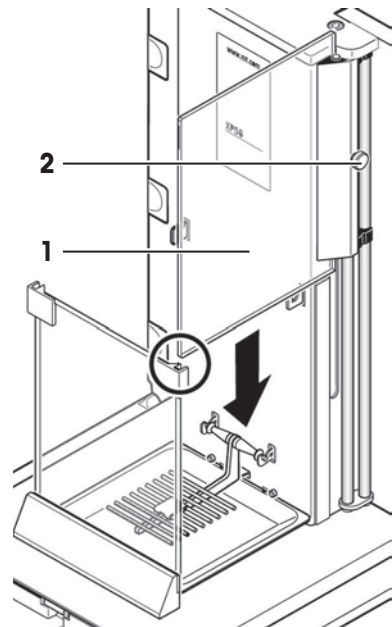

- 1 Put the top glass (1) on.
- 2 Insert the sealing cover (2).

Note

The sealing cover closes the opening in the top glass through which you can pipette into a high container.

Attention

Do not use the sealing cover to lift the top glass of the draft shield!

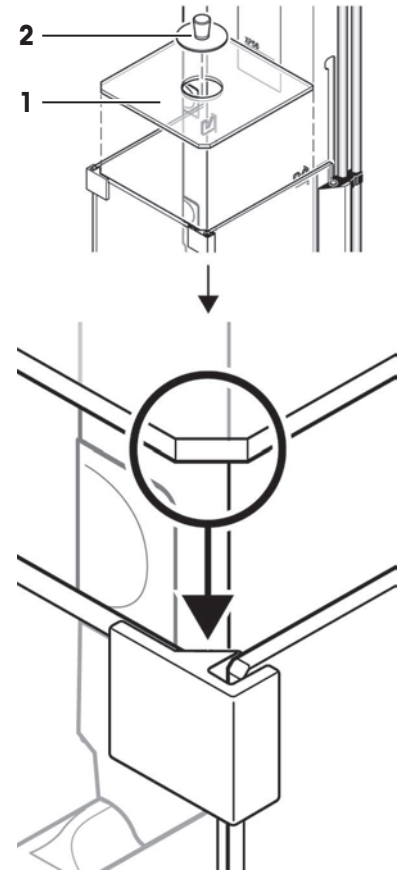

4.4.2 Outer draft shield

- 1 Insert the top door of the draft shield (1) at an angle (slightly less than 30 degrees) into the guide positioned at the **back**.
- 2 Swivel the draft-shield door (2) carefully down, **see** figure.

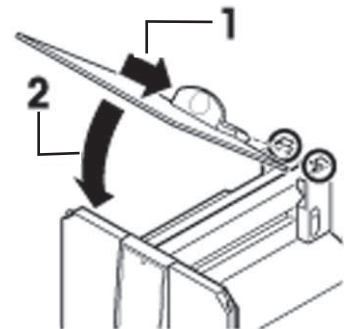

- ▶ The handles (A) must be turned toward the outside to allow installation of the side draft shield doors!
- 1 Insert the side doors of the draft shield according to the following instructions, **see** figure below.
 - 2 Insert the side door at an angle of approx. 30° into the 2 openings, **see** figure.
 - 3 Check that the side door is correctly inserted as shown!
 - 4 Swivel the side door up against the balance until it engages with a click.
 - 5 The side door must run easily, otherwise it is not correctly inserted.
 - 6 Insert the second side door of the draft shield.
 - ⇒ The procedure is identical.
 - 7 Push the side doors completely to the back.

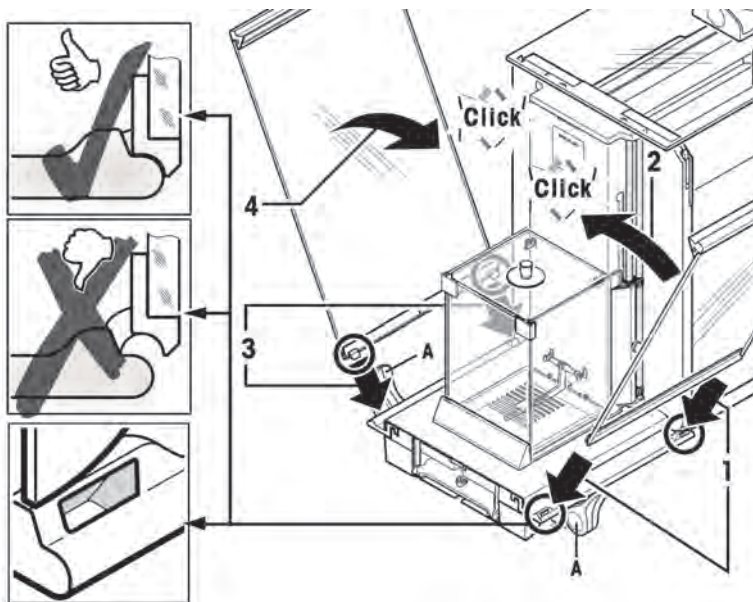

- 1 Insert the front glass (2) of the draft shield.
- 2 In the bottom part of the balance at the front, move at an angle from the top toward the bottom until the two hooks of the front glass of the draft shield lie on the rollers (1).
- 3 Swivel the front glass of the draft shield up until it engages.

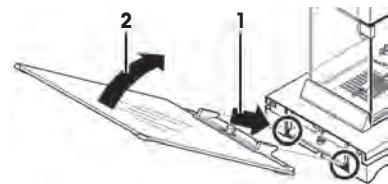

- 1 Insert the terminal support.
- 2 First lay the cable in the guide by the terminal support.
- 3 Insert the terminal support into the opening of the front glass of the draft shield.
 - ⇒ The terminal support must engage with a click.

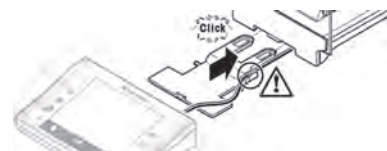

- 1 Mount the terminal.
- 2 Place the terminal in the center of the support.
- 3 Push it against the balance until it swivels slightly down at the front by the terminal support.
⇒ You can push the cable into the balance.

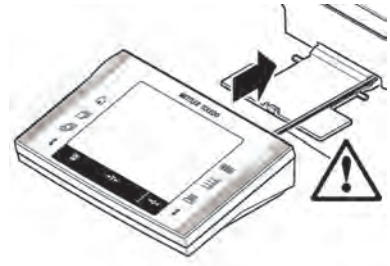

Attention

The balance and the terminal are not fastened together by the terminal support! When transporting by hand, always hold the balance and the terminal firmly.

Note

You can also place the terminal free of the terminal support anywhere around the balance where the length of the cable allows.

Also see

- Transporting the balance (page 20)

4.5 Connecting the balance



WARNING

Risk of electric shock

- a) To connect the balance, only use the supplied three-core power cord with equipment grounding conductor.
- b) Only connect the balance to a three-pin power socket with earthing contact.
- c) Only standardized extension cable with equipment grounding conductor must be used for operation of the balance.
- d) Intentional disconnection of the equipment grounding conductor is forbidden.

The balance is supplied with an AC adapter and country-specific power cord. The AC adapter is suitable for use with the following voltage range:

100 – 240 V AC, 50/60 Hz.

Attention

- Check whether your local power supply falls within this range. If this is not the case, under no circumstances connect the AC adapter to the power supply, but contact a METTLER TOLEDO representative.
- The power plug must be accessible at all times.
- Prior to use, check the power cord for damage.
- Route the cable in such a way that it cannot be damaged or cause a hindrance when working.
- Ensure that no liquid comes into contact with the AC adapter.

- ▶ Balance and terminal are at the final location.
- 1 Connect the AC adapter (1) to the connection socket (2) at the rear of the balance.
- 2 Connect the AC adapter (1) to the power supply.
- ⇒ The balance performs a self-test after connection to the power supply and is then ready to use.

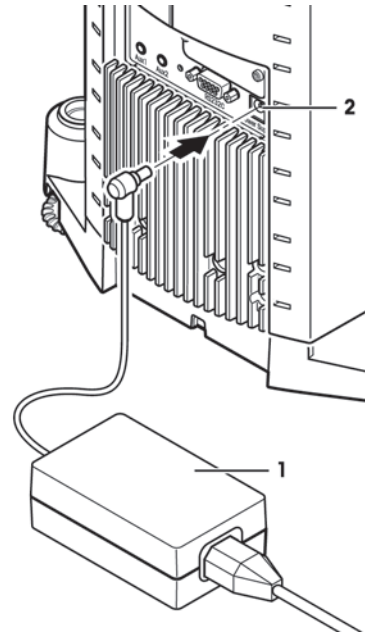

Note

If the display field remains dark, even though the power supply connection functions.

- 1 First disconnect the balance from the power supply.
- 2 Open the terminal.
- 3 Press both buttons (3) on the back of the terminal and open the upper part of the terminal.
- 4 Check that the plug for the terminal cable (4) is connected correctly inside the terminal.

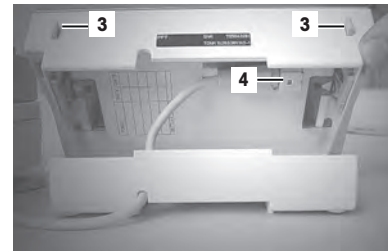

4.6 Operating of the outer draft shield and the inner draft shield

4.6.1 Outer draft shield

The outer draft shield of your balance can be adapted to the environmental conditions and your weighing style, as well as to the type of weighing and loading.

The doors of the outer draft shield can be opened and closed either by means of the [↕] key, the "SmartSens" sensors, or by hand, **see** Operating Instructions – Part 2.

Try various different combinations by moving the 3 external handles up/inside and down/outside. We recommend you to set up the outer draft shield so that it only opens on the side where the balance is loaded. Your balance then works faster, because there are fewer troublesome currents of air than when both doors of the outer draft shield are opened together.

- 1 For **motorized door operation** the handles must be connected.
 - ⇒ Side doors: Handles turned toward the inside.
 - ⇒ Top door: Handle down in horizontal position.
- 2 For **manual door operation** the handles must be disconnected.
 - ⇒ Side doors: Handles turned toward the outside.
 - ⇒ Top door: Handle up in vertical position.

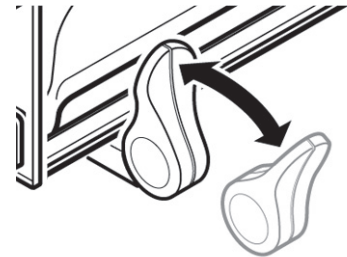
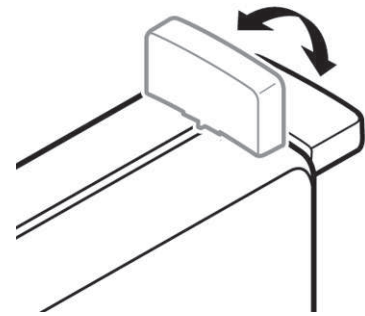

Note

It is best to make connections when the draft shield is closed.

4.6.2 Inner draft shield

- For **motorized operation** of the inner draft shield the coupling bolts (1) must be pressed **inward**.
 - ⇒ The two side doors can be controlled separately.

You can also open the side doors of the inner draft shield only part-way, with a choice of 25%, 50% or 75%, **see** Operating Instructions – Part 2.

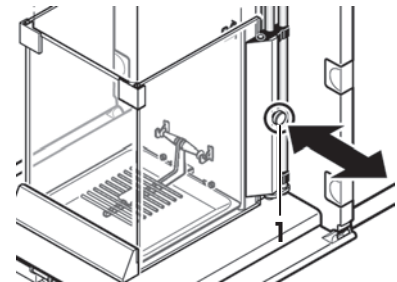

4.7 Setting the reading angle and positioning the terminal

4.7.1 Setting the reading angle

- 1 Press in the two buttons (1) on the back of the terminal.
 - ⇒ The top of the terminal can then be pulled up or pushed down until it engages in the desired position. A total of 3 setting positions are available.
- 2 Move it in an appropriate position.

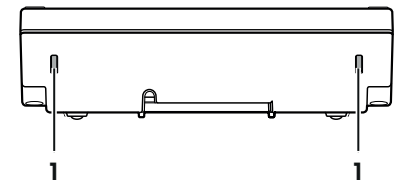

4.7.2 Remove terminal and place close to the balance

The terminal is connected to the balance by a cable. So you can arrange your workplace optimally, the terminal can be removed from the balance and placed separately.

Place the terminal separately

- 1 Switch the balance off.
- 2 Carefully lift the terminal off the terminal support.
You can leave the terminal support on the balance or remove it.
- 3 Pull the cable carefully out from the balance as far as possible.
- 4 Place the terminal where you want it to be.

Note

The cable can also be led out of the back of the balance. If working this way would be convenient for you, call your METTLER TOLEDO dealer who will adapt the balance for you.

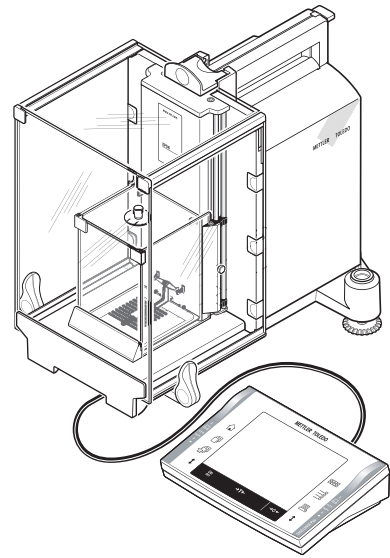

4.8 Transporting the balance

- 1 Switch off the balance.
- 2 The balance must be disconnected from the power supply.
- 3 Remove any interface cable from the balance.

4.8.1 Transporting over short distances

If you wish to move your balance over a short distance to a new location, proceed as follows.



CAUTION

Damage of device

Never lift the balance by the glass draft shield or the cooling element, as this can cause damage!

- 1 With one hand, hold the balance by the guide for the top door of the draft shield.
- 2 With your other hand, hold the terminal. The terminal is not rigidly fastened to the balance, so you must always hold the balance with one hand and the terminal with the other.
- 3 Carefully lift the balance and carry it to its new location.
See Selecting a location.

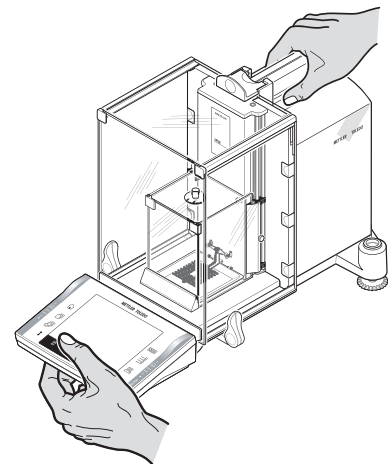

4.8.2 Transporting over long distances

If you want to transport or ship your balance over long distances, or if it is not certain that the balance will be transported upright, use the complete original packaging.

Disassemble the following parts

- 1 Lift the terminal (1) out of the terminal support and place it next to the support.
- 2 Pull the terminal support (2) off the balance.
- 3 Swivel the front glass (3) of the outer draft shield away from the balance.
- 4 Carefully fold the side doors (4+5) against the respective handles and pull the side doors out of the guide.
- 5 Swivel the front of the top door (6) of the outer draft shield up and pull the door out of the guide.
- 6 Remove the sealing cover (7).
- 7 Lift the top glass (8) of the inner draft shield off.
- 8 Pull both side doors (9 + 10) off. Pull up, turn to the side, and pull away.
- 9 Lift the SmartGrid (11) and lift it out of the guides.
- 10 Pull the drip tray (12) out at the side.
- 11 Pull the front glass (13) up and away.

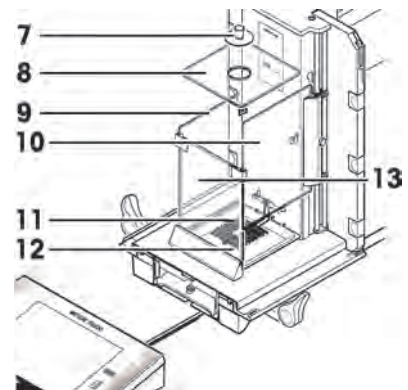
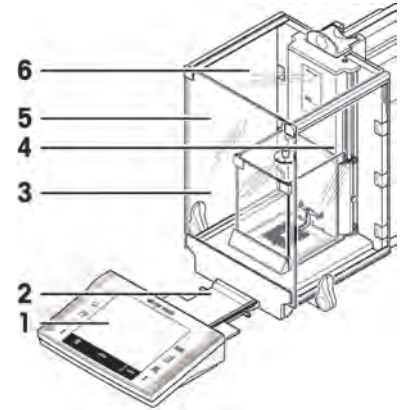

Pack the outer draft shield and the terminal support (Pos. 3-6 and 2)

- Place these parts in the compartments provided in the original packaging.

Note

We advise you to place a sheet of paper between the sides glasses of the draft shield.

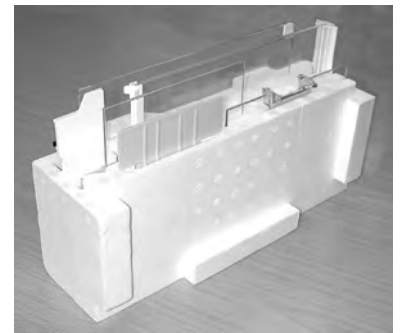

Pack the inner draft shield, the drip tray, and the SmartGrid (Pos. 7-13)

- Place these parts in the special compartments provided in the original packaging.



Pack the set with

- ErgoClip basket micro
 - Support (1)
 - Basket (2)
- SmartGrid cover micro (3).

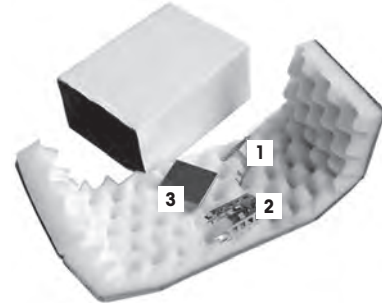

Pack the 2 sets (1 + 2)

- Set (1) with AC adapter, power cable, tweezers, and the set with the ErgoClip Basket micro and SmartGrid cover micro.
- Set (2) with the outer draft shield and terminal support.
- The Operating Instructions and other documents.

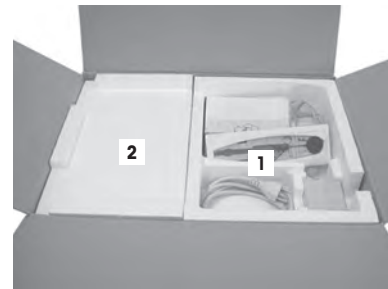

CAUTION

Damage of device

These instructions must be followed exactly, otherwise the balance may be damaged when inserting it into the packing cushions.

- 1 Push the guide of the upper draft shield door right to the front.
- 2 Push the guide of the draft shield side doors right to the front.
- 3 Fold the handles of the guides up/in.



Note

For packing both the balance and the terminal, you have a protective cover in which they were delivered. These are deliberately not shown in the illustrations so you can see better how the individual items must be positioned. However, we recommend you to use these protective covers.

- 1 Place the terminal on the balance (see illustration) and carefully insert the balance into the bottom packing cushion.
- 2 Take the terminal and place it in front of the packing cushion on the table.



- Place the set in the packing cushion along with the inner draft shield, **see** illustration.



- Insert the terminal into the packing cushion as shown in the illustration.



- 1 Now put the top packing cushion in place.
 - ⇒ Taking care to position it correctly.
- 2 Pass the lifting strap around both packing cushions, **see** illustration.
- 3 Tighten it until it lies close against the packaging.
 - ⇒ You can now lift the packed balance by the lifting strap and insert it into the transport carton.



- Place the packaging with the outer draft shield and AC adapter sets on the balance in the transportation carton.



4.9 Below-the-balance weighing

So that weighings can be carried out below the working surface (below-the-balance weighing), your balance is provided with a special hanger.

- 1 Switch off the balance with [**On/Off**].
 - 2 Disconnect the AC adapter cable at the rear of the balance.
 - 3 Disconnect any interface cables.
 - 4 Push all glass draft shield doors back.
 - 5 Lift the terminal off the terminal support.
 - 6 Open the terminal and carefully pull the connecting cable out.
 - 7 Place the terminal at the side of the balance.
 - 8 Move the balance over the edge of the table until the opening is visible from below, **see** diagram on the left.
 - 9 Slacken the screw until the cover plate can be turned to the side and the hanger for weighing below the balance is easily accessible.
 - 10 Fix the cover plate in the new position with the screw, **see** diagram on the right.
 - 11 Move the balance back to its original position.
 - 12 Connect the terminal cable and close the terminal.
 - 13 Place the terminal in the terminal support.
 - 14 Move all glass draft shield doors to the front.
 - 15 Fix any interface cables.
 - 16 Plug the AC adapter into the power supply socket at the rear of the balance.
 - 17 Switch on the balance with [**On/Off**].
- ⇒ The balance is now ready for mounting the below-the-balance weighing device.

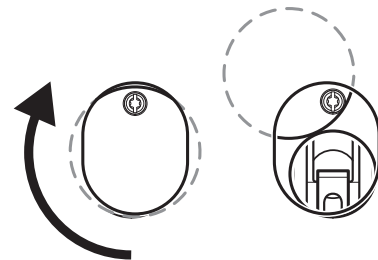

4.10 Installing the ErgoClip

Attention

Before you install an ErgoClip you must switch off the balance [**On/Off**] key.

To install the ErgoClip included in the delivery, or an optional ErgoClip, please proceed as follows:

- 1 Remove the SmartGrid from the balance.
- 2 Insert the support (1) for the "ErgoClip Basket micro".
- 3 Place the basket (2) on the guide (3) of the support.
- 4 Switch the balance on again [**On/Off**] key.

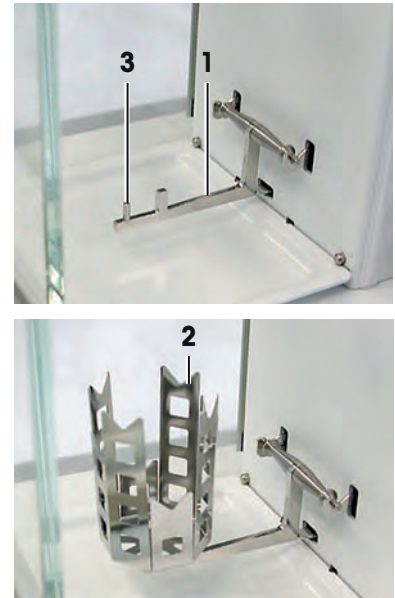

Important to know!

If you do not switch the balance off before you do the installation, the ProFACT function is not activated.

Reason

Addition of the ErgoClip causes the dead-load tolerance range of the balance to be exceeded. The balance therefore does not activate ProFACT, so as not to interrupt the **assumed** weighing operation.

When this status icon appears in the display, it means: "The balance wants to execute ProFACT" but cannot.



4.11 Installing the SmartGrid cover

Note

For standard operation with conventional tare containers, we do **not** recommend using this weighing pan. Its use may affect the stabilization time and degree of accuracy. The listed specifications are reached without a weighing pan.



CAUTION

Hand injuries

Take care when handling the weighing pan, the corners and edges are extremely sharp!

- Gloves must be worn.

Attention

With installed SmartGrid cover, the balance does not switch to "Standby" mode!

- 1 For the installation, remove the SmartGrid from the weighing chamber.
- 2 Gently press the cover onto the SmartGrid.
- 3 Replace the SmartGrid with the installed SmartGrid cover.

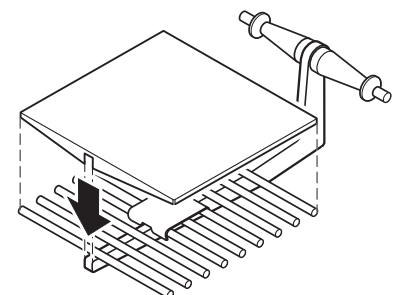

5 First Steps

5.1 Switching on / off

Switching on

- Press «**On/Off**».
- ⇒ The display appears.



Note

If the balance has not been set up exactly horizontally, a warning text will appear shortly after the balance is turned on, prompting you to level the balance.

Switching off

- Press «**On/Off**» until "Off" appears in the display.



Note

Do not disconnect the balance from the power supply except if you will not be using the balance for an extended period.

5.2 Leveling the balance

Your balance has a built-in levelcontrol, that constantly checks the correct horizontal alignment.

When the levelcontrol detects that the level is incorrect, a warning will appear and a warning beep will sound. A status icon will also appear in the upper right-hand corner of the display.



- 1 To start the Leveling Assistant, tap «**Info**».
 - ⇒ The Leveling Assistant will guide you step by step through the leveling process.
- 2 Watch the levelcontrol located of your balance and press the appropriate button of the current position.
 - ⇒ The Leveling Assistant will show you with red arrows in which direction you need to turn the two footscrews on the back of the balance.
- 3 Screw the footscrew until the air bubble is in the inner circle.
- 4 Tap «**Exit**».
 - ⇒ A message appears that advises you to adjust the balance.
- 5 Confirm with «**OK**».
 - ⇒ Status icon will no longer appear and balance returns to normal operation.

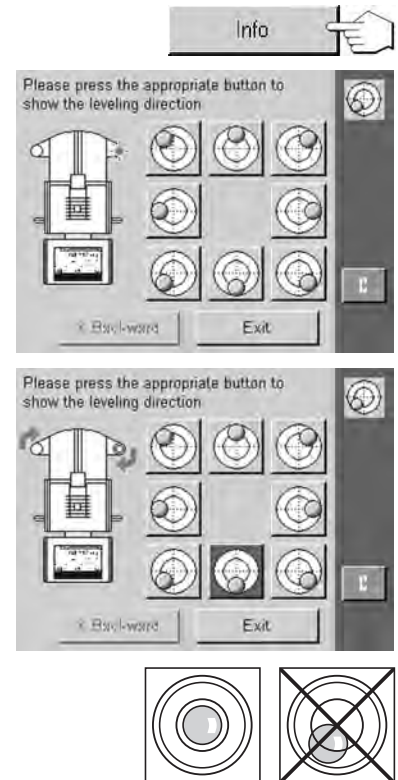

6 Maintenance

6.1 Cleaning

Periodically clean the weighing chamber, the housing, and the terminal of your balance using the brush supplied with it. The maintenance interval depends on your standard operating procedure (SOP).

Please observe the following notes



WARNING

Risk of electric shock

- a) Disconnect the balance from the power supply prior to cleaning and maintenance.
- b) Only use METTLER TOLEDO power cords, if these need to be replaced.
- c) Ensure that no liquid comes into contact with the balance, terminal or AC adapter.
- d) Do not open the balance, terminal or AC adapter.
These contain no user-serviceable parts.



CAUTION

Damage of balance

On no account use cleaning agents which contain solvents or abrasive ingredients, as this can result in damage to the terminal overlay.

Cleaning

Your balance is made from high quality, resistant materials and can therefore be cleaned with a commercially available, mild cleaning agent.

- 1 To clean the weighing chamber thoroughly, swivel the glasses of the draft shields (inner and outer draft shield) away from the balance and pull them out of their fastenings.
It may be necessary to turn the weighing pan slightly to remove it.
- 2 Carefully raise the front of the weighing pan and lift it out of the guide.
- 3 Pull the drip tray away from the balance.
- 4 When you replace these parts, make sure they are in the correct position.

Note

Please contact your METTLER TOLEDO dealer for details of the available service options. Regular servicing by an authorized service engineer ensures constant accuracy for years to come and prolongs the service life of your balance.

6.2 Disposal

In conformance with the European Directive 2002/96/EC on Waste Electrical and Electronic Equipment (WEEE) this device may not be disposed of in domestic waste. This also applies to countries outside the EU, per their specific requirements.



Please dispose of this product in accordance with local regulations at the collecting point specified for electrical and electronic equipment. If you have any questions, please contact the responsible authority or the distributor from which you purchased this device. Should this device be passed on to other parties (for private or professional use), the content of this regulation must also be related.

Thank you for your contribution to environmental protection.

7 Technical Data

7.1 General data



CAUTION

Use only with a tested AC Adapter with SELV output current.
Ensure correct polarity

Power supply

AC adapter:	Primary: 100 – 240 V AC, -15%/+10%, 50/60 Hz Secondary: 12 V DC $\pm 3\%$, 2.5 A (with electronic overload protection)
Cable for AC adapter:	3-core, with country-specific plug
Balance power supply:	12 V DC $\pm 3\%$, 2.25 A, maximum ripple: 80 mVpp

Protection and standards

Overvoltage category:	II
Degree of pollution:	2
Protection:	Protected against dust and water
Standards for safety and EMC:	See Declaration of Conformity
Range of application:	For use only in closed interior rooms

Environmental conditions

Height above mean sea level:	Up to 4000 m
Ambient temperature:	5–40 °C
Relative air humidity:	Max. 80% up to 31 °C, linearly decreasing to 50% at 40 °C, noncondensing
Warm-up time:	At least 120 minutes after connecting the balance to the power supply; when switched on from standby-mode, the balance is ready for operation immediately

Materials

Housing:	Die-cast aluminum, plastic, chrome steel and glass
Terminal:	Die-cast zinc, chromed and plastics
SmartGrid:	Chrome-nickel steel X5CrNi18-10

7.2 Explanatory notes for the METTLER TOLEDO AC adapter

The certified external power supply which conforms to the requirements for Class II double insulated equipment is not provided with a protective earth connection but with a functional earth connection for EMC purposes. This earth connection IS NOT a safety feature. Further information about conformance of our products can be found in the brochure "Declaration of Conformity" which is coming with each product.

In case of testing with regard to the European Directive 2001/95/EC the power supply and the balance have to be handled as Class II double insulated equipment.

Consequently an earth bonding test is not required. Similarly it is not necessary to carry out an earth bonding test between the supply earth conductor and any exposed metalwork on the balance.

Because the balance are sensitive to static charges a leakage resistor, typically 10 k Ω , is connected between the earth connector and the power supply output terminals. The arrangement is shown in the equivalent circuit diagram. This resistor is not part of the electrical safety arrangement and does not require testing at regular intervals.

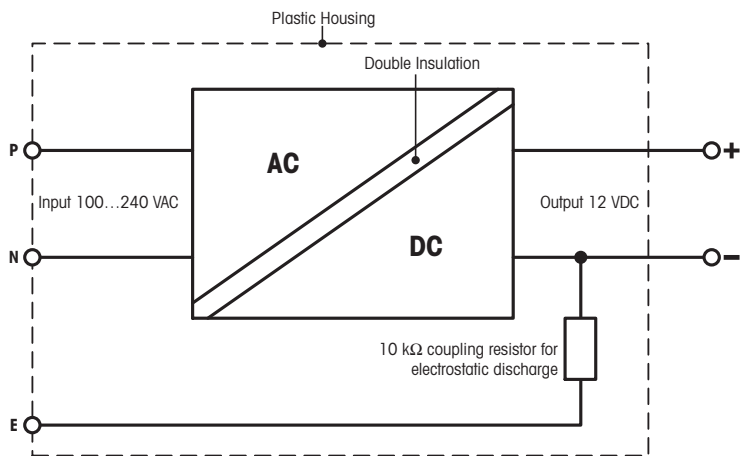

Equivalent circuit diagram

7.3 Model-specific data

		XP26	XP26DR
Limit values			
Maximum capacity		22 g	22 g
Readability		0.001 mg	0.01 mg
Tare range (from...to)		0 ... 22 g	0 ... 22 g
Maximum capacity, fine range		–	5.1 g
Readability, fine range		–	0.002 mg
Repeatability (at nominal load)	sd	0.0025 mg (20 g)	0.008 mg (20 g)
Repeatability (at low load)	sd	0.0015 mg (1 g)	0.005 mg (1 g)
Repeatability, fine range (at low load)	sd	–	0.002 mg (1 g)
Linearity deviation		0.004 mg	0.01 mg
Eccentricity deviation (test load) ¹⁾		0.02 mg (10 g)	0.025 mg (10 g)
Sensitivity offset (test weight)		0.08 mg (20 g)	0.1 mg (20 g)
Sensitivity temperature drift ²⁾		0.0001%/°C	0.0001%/°C
Sensitivity stability ³⁾		0.0001%/a	0.0001%/a
Typical values			
Repeatability (at low load)	sd	0.0007 mg	0.004 mg
Repeatability, fine range	sd	–	0.0012 mg
Linearity deviation		0.003 mg	0.0048 mg
Eccentric deviation (test load) ¹⁾		0.006 mg (10 g)	0.008 mg (10 g)
Sensitivity offset (test weight)		0.04 mg (20 g)	0.048 mg (20 g)
Minimum sweight (according to USP)		1.4 mg	8 mg
Minimum weight (according to USP), fine range		–	2.4 mg
Minimum weight (U=1%, k=2)		0.14 mg	0.8 mg
Minimum weight (U=1%, k=2), fine range		–	0.24 mg
Settling time		3.5 s	2.5 s
Settling time, fine range		–	3.5 s
Dimensions			
Balance dimensions (W × D × H)		263 × 487 × 322 mm	263 × 487 × 322 mm
Weighing pan dimensions		40 × 40 mm (W × D)	40 × 40 mm (W × D)
Typical uncertainties and supplementary data			
Repeatability	sd	0.0007 mg + 0.000004%·Rgr	0.004 mg + 0.000005%·Rgr
Repeatability, fine range	sd	–	0.0012 mg + 0.00001%·Rgr
Differential linearity deviation	sd	√(0.12pg·Rnt)	√(0.3pg·Rnt)
Differential eccentric load deviation	sd	0.00003%·Rnt	0.00004%·Rnt
Sensitivity offset	sd	0.0001%·Rnt	0.00012%·Rnt
Minimum weight (according to USP)		1.4 mg + 0.008%·Rgr	8 mg + 0.01%·Rgr
Minimum weight (according to USP), fine range		–	2.4 mg + 0.02%·Rgr

	XP26	XP26DR
Minimum weight (U=1%, k=2)	0.14 mg + 0.0008%·Rgr	0.8 mg + 0.001%·Rgr
Minimum weight (U=1%, k=2), fine range	–	0.24 mg + 0.002%·Rgr
Weighing time	18 s	14 s
Weighing time, fine range	–	18 s
Interface update rate	23 /s	23 /s
Weight of balance	11.5 kg	11.5 kg
Number of built-in reference weights	2	2
Weights for routine testing		
OIML CarePac	20 g F1, 1 g E2	20 g F1, 1 g E2
Weights	#11123006	#11123006
ASTM CarePac	20 g 1, 1 g 1	20 g 1, 1 g 1
Weights	#11123106	#11123106

sd = Standard deviation

Rnt = Net weight (sample weight)

Rgr = Gross weight

a = Year (annum)

1) Valid for compact objects

2) After adjustment with built-in reference weight

3) On DeltaRange models: fine range starts at zero load (gross)

	XP56	XP56DR
Limit values		
Maximum capacity	52 g	52 g
Readability	0.001 mg	0.01 mg
Tare range (from...to)	0 ... 52 g	0 ... 52 g
Maximum capacity, fine range	–	11 g
Readability, fine range	–	0.002 mg
Repeatability (at nominal load)	sd 0.006 mg (50 g)	0.014 mg (50 g)
Repeatability (at low load)	sd 0.0015 mg (1 g)	0.006 mg (1 g)
Repeatability, fine range (at low load)	sd –	0.002 mg (1 g)
Linearity deviation	0.2 mg	0.03 mg
Eccentricity deviation (test load) ¹⁾	0.03 mg (20 g)	0.035 mg (20 g)
Sensitivity offset (test weight)	0.125 mg (50 g)	0.15 mg (50 g)
Sensitivity temperature drift ²⁾	0.0001%/°C	0.0001%/°C
Sensitivity stability ³⁾	0.0001%/a	0.0001%/a
Typical values		
Repeatability (at low load)	sd 0.0007 mg	0.004 mg
Repeatability, fine range	sd –	0.0012 mg
Linearity deviation	0.01 mg	0.015 mg
Eccentric deviation (test load) ¹⁾	0.012 mg (20 g)	0.016 mg (20 g)
Sensitivity offset (test weight)	0.06 mg (50 g)	0.08 mg (50 g)
Minimum sweight (according to USP)	1.4 mg	8 mg
Minimum weight (according to USP), fine range	–	2.4 mg
Minimum weight (U=1%, k=2)	0.14 mg	0.8 mg
Minimum weight (U=1%, k=2), fine range	–	0.24 mg
Settling time	3.5 s	2.5 s
Settling time, fine range	–	3.5 s
Dimensions		
Balance dimensions (W × D × H)	263 × 487 × 322 mm	263 × 487 × 322 mm
Weighing pan dimensions	40 × 40 mm (W × D)	40 × 40 mm (W × D)
Typical uncertainties and supplementary data		
Repeatability	sd 0.0007 mg + 0.000006%·Rgr	0.004 mg + 0.000006%·Rgr
Repeatability, fine range	sd –	0.0012 mg + 0.00001%·Rgr
Differential linearity deviation	sd $\sqrt{(0.5pg \cdot Rnt)}$	$\sqrt{(1.2pg \cdot Rnt)}$
Differential eccentric load deviation	sd 0.00003%·Rnt	0.00004%·Rnt
Sensitivity offset	sd 0.00006%·Rnt	0.00008%·Rnt
Minimum weight (according to USP)	1.4 mg + 0.012%·Rgr	8 mg + 0.012%·Rgr
Minimum weight (according to USP), fine range	–	2.4 mg + 0.02%·Rgr

	XP56	XP56DR
Minimum weight (U=1%, k=2)	0.14 mg + 0.0012%·Rgr	0.8 mg + 0.0012%·Rgr
Minimum weight (U=1%, k=2), fine range	–	0.24 mg + 0.002%·Rgr
Weighing time	18 s	14 s
Weighing time, fine range	–	18 s
Interface update rate	23 /s	23 /s
Weight of balance	11.5 kg	11.5 kg
Number of built-in reference weights	2	2
Weights for routine testing		
OIML CarePac	50 g F2, 2 g E2	2 g E2, 0.1 g E2
Weights	#11123003	#11123004
ASTM CarePac	50 g 1, 2 g 1	2 g 1, 0.1 g 1
Weights	#11123103	#11123104

sd = Standard deviation

Rnt = Net weight (sample weight)

Rgr = Gross weight

a = Year (annum)

1) Valid for compact objects

2) After adjustment with built-in reference weight

3) On DeltaRange models: fine range starts at zero load (gross)

7.4 Dimensions

Dimensions in mm.

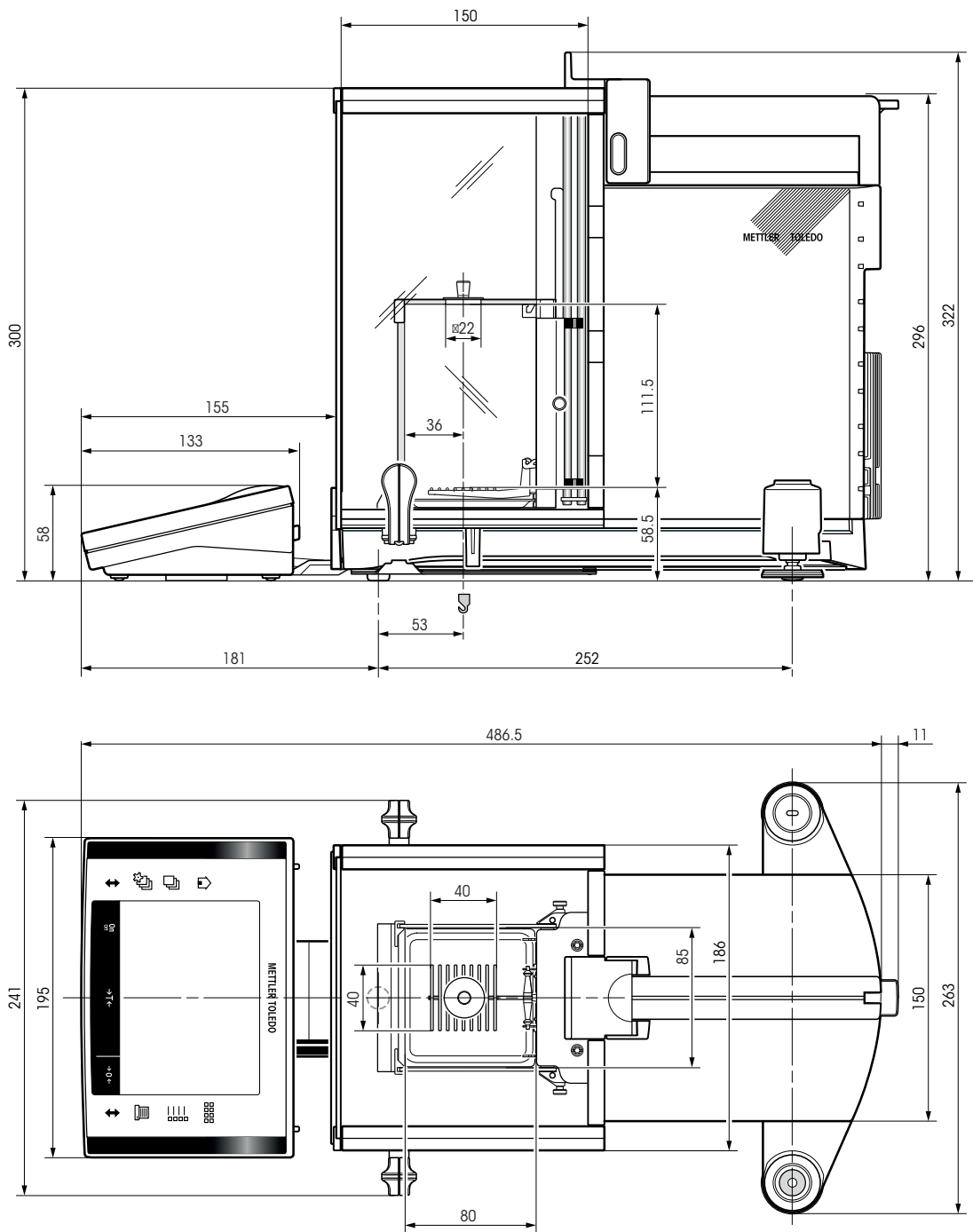

7.5 Interfaces

7.5.1 Specifications of RS232C

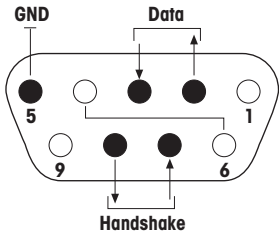
Interface type:	Voltage interface according to EIA RS-232C/DIN 66020 (CCITT V24/V.28)	
Max. cable length:	15 m	
Signal level:	Outputs: +5 V ... +15 V (RL = 3 – 7 kΩ) –5 V ... –15 V (RL = 3 – 7 kΩ)	Inputs: +3 V ... 25 V –3 V ... 25 V
Connector:	Sub-D, 9-pole, female	
Operating mode:	Full duplex	
Transmission mode:	Bit-serial, asynchronous	
Transmission code:	ASCII	
Baud rates:	600, 1200, 2400, 4800, 9600, 19200, 38400 ¹⁾ (firmware selectable)	
Bits/parity:	7-bit/even, 7-bit/odd, 7-bit/none, 8-bit/none (firmware selectable)	
Stop bits:	1 stop bit	
Handshake:	None, XON/XOFF, RTS/CTS (firmware selectable)	
End-of-line:	<CR><LF>, <CR>, <LF> (firmware selectable)	
	Pin 2: Balance transmit line (TxD) Pin 3: Balance receive line (RxD) Pin 5: Ground signal (GND) Pin 7: Clear to send (hardware handshake) (CTS) Pin 8: Request to send (hardware handshake) (RTS)	

- ¹⁾ 38400 baud is only possible in special cases, such as:
- Weighing platform without terminal, or
 - Weighing platform with terminal, only via the optional RS232C interface.

7.5.2 Specifications of "Aux" connection

You can connect the METTLER TOLEDO "ErgoSens" or an external switch to sockets "Aux 1" and "Aux 2". This allows you to start functions such as taring, zeroing, printing and others.

External connection

Connector:	3.5 mm stereo jack connector	
Electrical data:	Max. voltage	12 V
	Max. current	150 mA

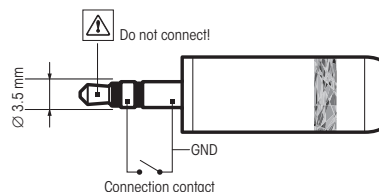

8 Accessories and Spare Parts

8.1 Accessories

You can increase the functionality of your balance with accessories from the METTLER TOLEDO range. The following options are available:

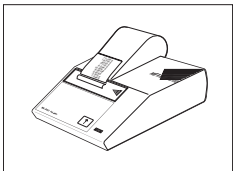
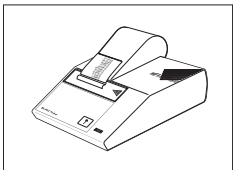
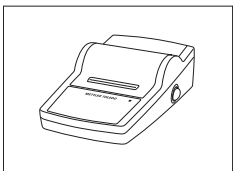
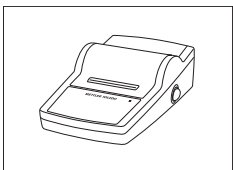
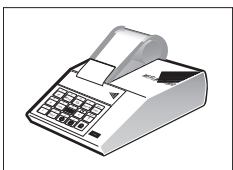
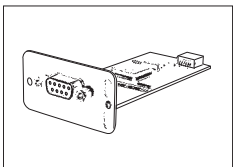
	Description	Part No.
Printers		
	BT-P42 printer with Bluetooth connection to instrument	11132540
	Paper roll, set of 5 pcs	00072456
	Paper roll, self-adhesive, set of 3 pcs	11600388
	Ribbon cartridge, black, set of 2 pcs	00065975
	RS-P42 printer with RS232C connection to instrument	00229265
	Paper roll, set of 5 pcs	00072456
	Paper roll, self-adhesive, set of 3 pcs	11600388
	Ribbon cartridge, black, set of 2 pcs	00065975
	RS-P25 printer with RS232C connection to instrument	11124300
	Paper roll, set of 5 pcs	00072456
	Paper roll, self-adhesive, set of 3 pcs	11600388
	Ribbon cartridge, black, set of 2 pcs	00065975
	RS-P26 printer with RS232C connection to instrument (with date and time)	11124303
	Paper roll, set of 5 pcs	00072456
	Paper roll, self-adhesive, set of 3 pcs	11600388
	Ribbon cartridge, black, set of 2 pcs	00065975
	LC-P45 application printer with additional functions	00229119
	Paper roll, set of 5 pcs	00072456
	Paper roll, self-adhesive, set of 3 pcs	11600388
	Ribbon cartridge, black, set of 2 pcs	00065975
Optional interfaces		
	Second RS232C Interface	11132500

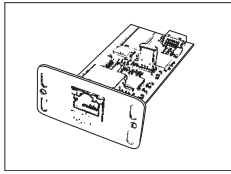

Ethernet Interface for connection to an Ethernet network

11132515



BT option: Bluetooth Interface for multipoint connection for up to 6 Bluetooth devices

11132530



BTS option: Bluetooth Interface, single-point connection

11132535



PS/2 option: Interface for connecting commercial keyboards and barcode readers

11132520

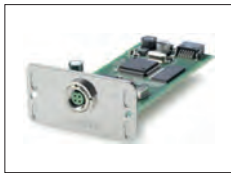

LocalCAN option: Interface for connection of up to 5 LC (LocalCAN) instruments

11132505



MiniMettler option: Interface MiniMettler, for connection to older (legacy) METTLER TOLEDO systems

11132510

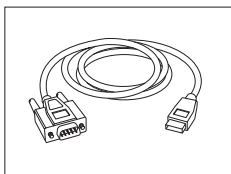

RS232 - USB converter cable – Cable with converter to connect a balance (RS232) to a USB port

64088427

Cables for RS232C interface

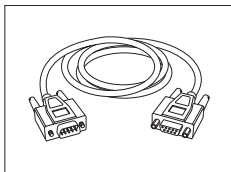

RS9 – RS9 (m/f): connection cable for PC, length = 1 m

11101051

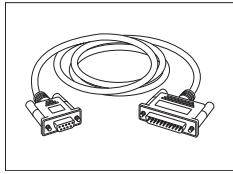

RS9 – RS25 (m/f): connection cable for PC, length = 2 m

11101052

Cables for LocalCAN interface

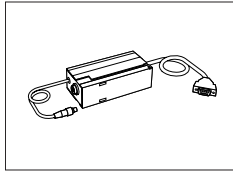

LC – RS9: Cable for connecting a PC with RS232C, 9-pin (f), length = 2 m

00229065

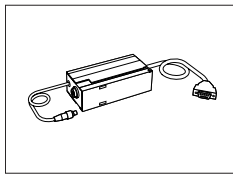

LC – RS25: Cable for connecting a printer or PC with RS232C, 25-pin (m/f), length = 2 m

00229050



LC – CL: Cable for connecting a device with METTLER TOLEDO CL interface (5-pin), length = 2 m

00229130



LC – LC2: Extension cable for LocalCAN, length = 2 m

00229115



LC – LC5: Extension cable for LocalCAN, length = 5 m

00229116



LC – LCT: Cable branch (T-connector) for LocalCAN

00229118

Cables for MiniMettler interface

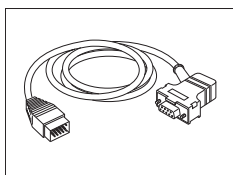

MM – RS9f: RS232C connection cable to MiniMettler interface, length = 1.5 m

00229029

Cables for terminal

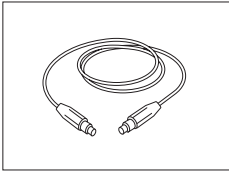

Terminal extension cable, length = 4.5 m

11600517

Cable, one-sided open (2-pin)

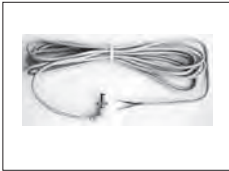

Cable between balance and AC adapter, length = 4 m

11132037

Auxiliary displays

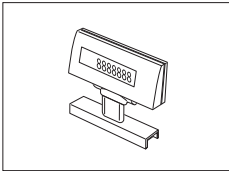

BT-BLD Bluetooth auxiliary display for table mounting, 168 mm, LCD display with backlighting

11132555

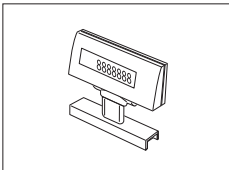

LC/RS-BLD auxiliary display on bench stand, backlit (incl. RS cable and separate AC adapter)

00224200



RS/LC-BLDS auxiliary display for table or balance mounting, 480 mm, LCD display with backlighting

11132630

Sensors

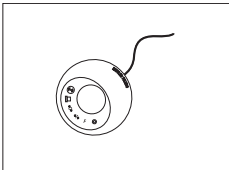

ErgoSens, optical sensor for hands-free operation

11132601

LC-Switchbox



For connection of up to 3 balances with LocalCAN interface to a printer

00229220

Footswitches

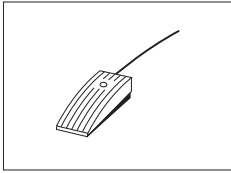

Footswitch with selectable function for balances (Aux 1, Aux 2)

11106741



LC-FS foot switch with selectable function for balances with LocalCAN interface

00229060

AntiStatic kit

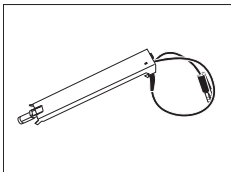

Compact Antistatic Kit. Eliminates the build-up of electrostatic charges on containers and samples.

30090337

Note For the operation of 2 compact Antistatic Kits, an additional AC adapter can be ordered, **see** Various accessories.

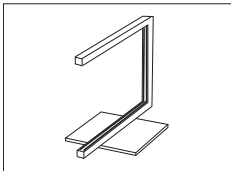

Universal AntiStatic Kit complete (U-shaped), including electrode and power supply

11107767

Optional: Second U-electrode* for universal AntiStatic Kit

11107764

* Power supply for optional, second U-electrode (11107764)

11107766

ErgoClips



ErgoClip "Basket micro" (basket for small weighing objects)

11107889



ErgoClip "Flask micro" (for volumetric flask)

11107879



ErgoClip "Stand micro" (Holder to store up to 3 ErgoClips)

11140175



ErgoClip "Solution Kit micro"

11140253

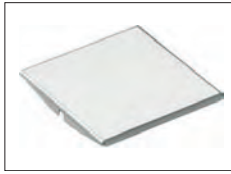

SmardGrid cover, chromium-nickel steel

11106262



Single-use weighing boats, 500 units, 41 × 56 × 8 mm

11106712



MinWeigh Door micro ideal for use with ErgoClip "Flask micro"

11107869

XP-SE kit



Separate electronics kit
Extension cable 0.6 m
Extension cable 5.0 m

11106743

00211535

00210688

Pipette calibration



Evaporation Trap micro

11140041



1-channel suction pump complete
Hose 2 m for suction pump

11138268

11138132



Reagent reservoirs, 5 pcs.

11600616



Barometer

11600086

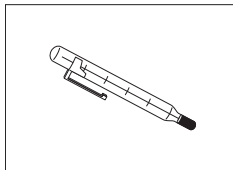
	Precision thermometer with clip, not certified	00238767
---	--	----------

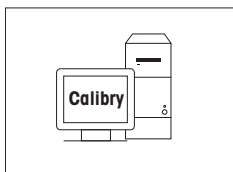
	Calibry PC Software Calibry Light; for single channel pipettes Update Calibry Single workstation; for calibration with one system MPC Update Calibry Network; Installation on several PC of the network accessing the same database Update Calibry Validation manual	11138423 30007342 11138419 30007340 11138420 30007341 11780959
---	--	--

Barcode reader

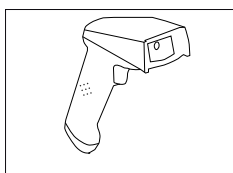
	RS232C Barcode Reader The following accessories are needed for operation (not included): RS232 F cable Null modem adapter Plus one of the following: AC adapter 5 V for EU AC adapter 5 V for US AC adapter 5 V for GB AC adapter 5 V for AU	21901297 + 71209966
---	---	--

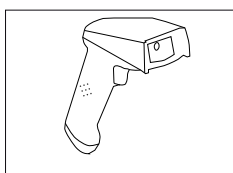
	RS232C Barcode Reader – Cordless The following accessories are needed for operation (not included): Cradle RS232 F cable Null modem adapter Plus one of the following: AC adapter 12 V for EU AC adapter 12 V for US AC adapter 12 V for GB AC adapter 12 V for AU	21901299 + 71209966
---	--	--

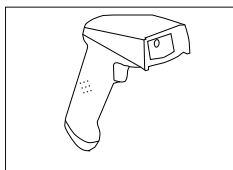
	PS/2 Barcode Reader, without cable PS/2 wedge single cable	21901297 21901307
---	--	----------------------

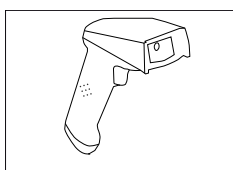
	PS/2Y Barcode Reader, without cable PS/2 wedge twin (Y) cable	21901297 21901308
---	---	----------------------

Anti-theft devices

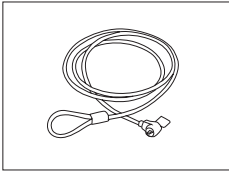

Steel cable

11600361

Transport cases



Transport case

11106729

Protective covers

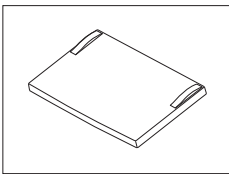

Protective cover for XP terminal

11132570

Dust covers



Dust cover

30035838

Software

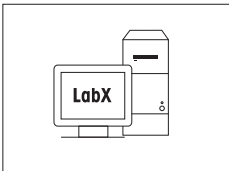

LabX software for one click™ weighing solutions

Enables you to perform One Click™ Standard Preparation, One Click™ Loss on Drying, One Click™ Sieve Analysis and many other applications.

Simply start the method with the One Click™ shortcut on the balance touchscreen. LabX guides you step-by-step through the SOP on the balance, performs your calculations automatically, and takes care of saving all your data. The complete solution can be tailored to match your process requirements. Visit www.mt.com/one-click-weighing for more information

on request

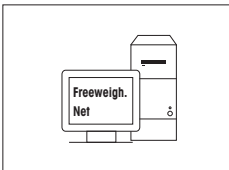

Freeweigh.Net

21900895

Various



Terminal and printer stand, mounting on balance

11106730

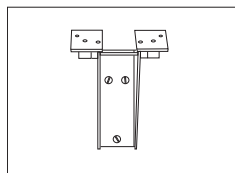

Wall fixture for terminal

11132665

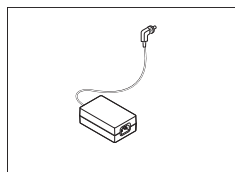

AC/DC adapter (without power cable) 100–240 V AC, 0.8 A,
50/60 Hz, 12 V DC 2.5 A

11107909

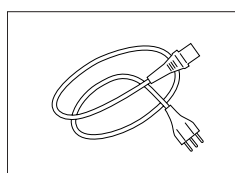

Country-specific 3-Pin power cable with grounding conductor.

Power cable AU	00088751
Power cable BR	30015268
Power cable CH	00087920
Power cable CN	30047293
Power cable DK	00087452
Power cable EU	00087925
Power cable GB	00089405
Power cable IL	00225297
Power cable IN	11600569
Power cable IT	00087457
Power cable JP	11107881
Power cable TH, PE	11107880
Power cable US	00088668
Power cable ZA	00089728

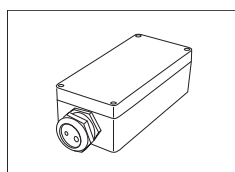

IP54 protective housing for AC adapter

11132550

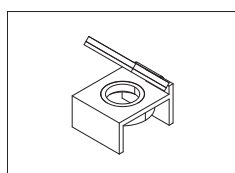

Level bubble mirror

11140150

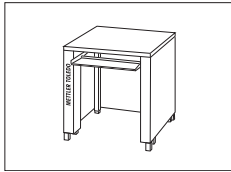

Weighing table

11138042

8.2 Spare parts

	Pos	Description	Part No.
	1	Front glass outer draft shield (IR protection)	11107994
	2	Side outer draft shield door	11106841
	3	Top outer draft shield door	11106842
	4	Intermediate shelf	11106803
	5	Clip	11106511
	6	Foot screw	11106323
	7	Terminal support	11106540
	8	Drip tray	11106687
	9	SmartGrid	11106403
	10	SmartGrid cover	11106262
	11	Front glass inner draft shield	11107996
	12	Side glass inner draft shield	11107995
	13	Sealing cover inner draft shield	11106690
	14	Glass cover inner draft shield	11106689
	15	XP Terminal complete with firmware	11130692
	Packaging complete		11107998

	Pos	Description	Part No.
		Export box	11106657

9 Appendix

9.1 MT-SICS interface commands and functions

Many of the instruments and balances used have to be capable of integration in a complex computer or data acquisition system.

To enable you to integrate balances in your system in a simple manner and utilize their capabilities to the full, most balance functions are also available as appropriate commands via the data interface.

All new METTLER TOLEDO balances launched on the market support the standardized command set "METTLER TOLEDO Standard Interface Command Set" (MT-SICS). The commands available depending on the functionality of the balance.

For further information please refer to the Reference Manual MT-SICS downloadable from the Internet under

► <http://www.mt.com/micro>

9.2 Procedure for certified balances

Preface

Certified balances are subject to the national, legal requirements of "non-automatic balances".

Switching on the balance

- **Switching on**
 - Immediately after being switched on, the balance displays 0.000.. g.
 - The balance is always started up with the "Factory setting" unit.
- **Switch-on range**
 - At maximum 20% of the type load, otherwise overload is displayed (OIML R76 4.5.1).
- **Stored value as switch-on zero point**
 - It is not permissible to use a stored value as a switch-on zero point; the MT-SICS M35 command is not available (OIML R76 T.5.2).

Display

- **Display of the weight value**
 - The "e" certification value is always shown in the display and is specified at the model designation plate (OIML R76 T.3.2.3 and 7.1.4).
 - If the display increment is lower than the "e" certification value, this is variably displayed for the net, gross and weighed tare. (Graying of the digits or certification brackets) (OIML R76 T.2.5.4 and 3.4.1).
- In accordance with guidelines, the tested display increment (certification value) is never lower than 1 mg (OIML R76 T.3.4.2).
- At balances with $d = 0.1$ mg, the digits below 1 mg are displayed in gray. These digits in brackets are printed. In accordance with legal metrology requirements, this illustration does not affect the accuracy of the weighing results.
- **Units of measurement**
 - The display and info unit are firmly set to g or mg (depending on the model).
 - The following applies for the "Custom unit":
 - No certification brackets.
 - The following names are blocked, this applies to upper and lower case letters.
 - All official units (g, kg, ct etc.).
 - c, ca, car, cm, crt, cart, kt, gr, gra, gram, grm, k, kilo, to, ton.
 - All names with "o" which can be replaced by a zero (Oz, Ozt etc.).

- **Identification of the weight display**

- Gross, net, tare and other weight values are accordingly marked (OIML R76 4.6.5).
 - Net for net when a tare value has been used.
 - B or G for gross.
 - T for the weighed tare.
 - PT for the specified tare.
 - * or diff for the difference between the net or gross.

- **Info field**

- The info weight value is handled metrologically in the same way as the weight value in the main display.

Printout (OIML R76 4.6.11)

- If a tare value is entered manually (PreTare), the PreTare value is always printed along with the net value (PT 123.45 g).
- The printed weight values are identified in the same way as the weight value on the display. I.e. N, B or G, T, PT, diff or *, with differentiation.

Example:

Single-range balance.

N	123.4[5] g
PT	10.00 g → for PreTare
G	133.4[5] g

DR balance with 100.00 g fine range.

N	80.4[0] g
T	22.5[6] g → for weighed tare
G	102.9[] g

Balance functions

- **Reset to zero**

- The zero range is limited to a maximum of $\pm 2\%$ of the full load (OIML R76 4.5.1).

- **Tare**

- No negative tare values are permitted.
- Tare immediate (TI) is not permitted, the MT-SICS `TI` command is not available (OIML R76 4.6.4).

- **1/xd**

- **e = d**

The 1/xd switchover is not permitted (OIML R76 3.1.2).

- **e = 10d**

This is only permitted in the case of the 1/10d switchover.

- **e = 100d**

Only the 1/10d and 1/100d switchover are permitted.

Index

A

AC adapter	18, 29, 29
Accessories	35
Aux connections	34

B

Balance functions	47
Below-the-balance weighing	24

C

Certified balances	46
Cleaning	28
Connecting the balance	18
Connecting to power supply	18
Conventions	6

D

Dimensions	33
Display	46
Display field remains dark	18
Display of the weight value	46
Disposal	28

E

Environmental conditions	29
ErgoClip	10, 24
ErgoSens	34

F

Features	5
----------	---

G

General safety information	7
GLP	5
Good Laboratory Practice	5

I

Identification of the weight display	47
Info field	47
Inner draft shield	13, 19
Installing the SmartGrid cover	25
Interface	
MT-SICS	46
ISO 14001	5
ISO 9001	5

L

Level sensor	26
Levelcontrol	26
Leveling Assistant	27
Local conditions	12
Location	12

M

Materials	29
MT-SICS	46

O

Outer draft shield	18
Overview	9

P

Pack	21
Power cord	17
Power supply	29
Power supply voltage	17
Printout	47
Protection and standards	29

R

Remove terminal	19
Reset to zero	47
RS232C interface	34

S

Safety information	7
General	7
Staff safety	8
Scope of delivery	12
Self-test	18
Setting the reading angle	19
Setting up	10
SmartSens	18
Spare parts	45
Staff safety	8
Switching off	26
Switching on	26

T

Tare	47
Technical data	29
Transporting over long distances	21
Transporting over short distances	20
Transporting the balance	20

U

Units of measurement	46
Unpacking the balance	10, 11

GWP® – Good Weighing Practice™

The global weighing guideline GWP® reduces risks associated with your weighing processes and helps to

- choose the appropriate balance
- reduce costs by optimizing testing procedures
- comply with the most common regulatory requirements

► www.mt.com/GWP

www.mt.com/excellence

For more information

Mettler-Toledo AG, Laboratory & Weighing Technologies

CH-8606 Greifensee, Switzerland

Tel. +41 (0)44 944 22 11

Fax +41 (0)44 944 30 60

www.mt.com

Subject to technical changes.
© Mettler-Toledo AG 11/2013
11780841C en

