

bPro H22 Hanging Scale

bPro H22

Description	Specifications – bPro-H22
Capacity x Division	6 x 0.002 kg / 15 x 0.005 kg 15 x 0.005 lb / 30 x 0.01 lb
Weighing Modes	lb , kg, (single and dual interval)
Weight of Unit	25.5 lb (11.6 kg)
Shipping Weight	30.5 lb (13.8 kg)
Shipping Carton	L 31.4 in (798 mm), W 15 in (381 mm), H 13 (330 mm)
Construction	Metal frame, plastic covers
Operator Display	Backlit monochrome 240 x 240 LCD
Operator Keyboard	99 key tactile keypad with rubber overlay
Customer Display	Backlit monochrome 240 x 240 LCD
Printer	2.2" (56mm) max width labels up to 4.5" (115mm)/sec - 5" roll capacity
Power	100-240 VAC, 50/60 Hz, 2.0A
Operating Temperature	0° C to 40° C, humidity, 5% to 95% non condensing
Storage Temperature	-20° C to 70° C with humidity from 5% to 95% non-condensing
Network Interface*	Ethernet Standard 10/100 MBPS RS-232 Host Communications
Storage Memory	4 Megabytes RAM
Optional Storage	8 Megabyte expansion
Available Serial port	Two



*Wireless network security supported
 · WEP 40/64 & 104/128 bit
 · WPA/PSK – TKIP
 · WPA/PSK – AES
 · WPA2/PSK – TKIP
 · WPA2/PSK – AES-CCM
 *PSK - Pre-Shared Key

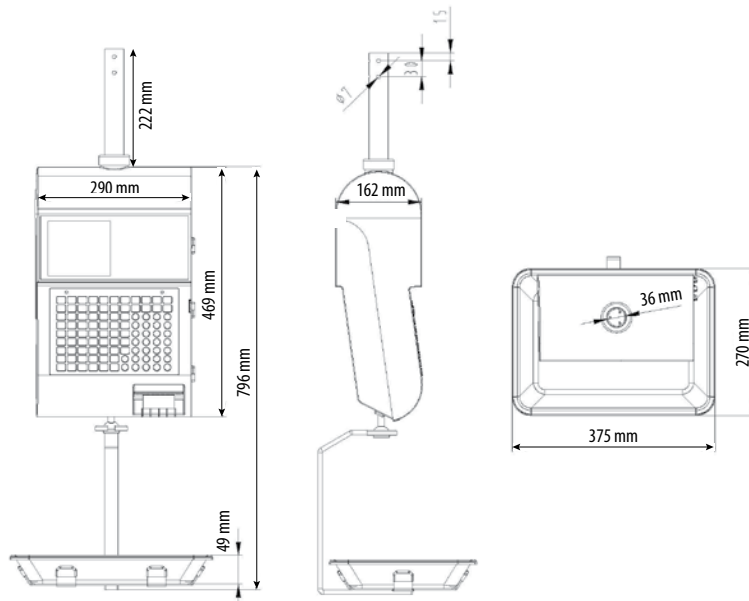

METTLER TOLEDO

Quality certificate ISO 9001
 Environment certificate ISO 14001
 Internet: <http://www.mt.com>
 Worldwide service

Subject to technical changes
 © 2016 Mettler-Toledo, LLC

RT1237.3E