

# TLD250

## Static Camera Dimensioning System







# METTLER TOLEDO Service

Congratulations on choosing the quality and precision of METTLER TOLEDO. Proper use of your new equipment according to this Manual and regular calibration and maintenance by our factory-trained service team ensures dependable and accurate operation, protecting your investment. Contact us about a service agreement tailored to your needs and budget. Further information is available at [www.mt.com/service](http://www.mt.com/service).

There are several important ways to ensure you maximize the performance of your investment:

- 1 **Register your product:** We invite you to register your product at [www.mt.com/productregistration](http://www.mt.com/productregistration) so we can contact you about enhancements, updates and important notifications concerning your product.
- 2 **Contact METTLER TOLEDO for service:** The value of a measurement is proportional to its accuracy – an out of specification dimensioning system can diminish quality, reduce profits and increase liability. Timely service from METTLER TOLEDO will ensure accuracy and optimize uptime and equipment life.
  - ➔ **Installation, Configuration, Integration and Training:** Our service representatives are factory-trained weighing equipment experts. We make certain that your weighing equipment is ready for production in a cost effective and timely fashion and that personnel are trained for success.
  - ➔ **Initial Calibration Documentation:** The installation environment and application requirements are unique for every dimensioning system so performance must be tested and certified. Our calibration services and certificates document accuracy to ensure production quality and provide a quality system record of performance.
  - ➔ **Periodic Calibration Maintenance:** A Calibration Service Agreement provides on-going confidence in your weighing process and documentation of compliance with requirements. We offer a variety of service plans that are scheduled to meet your needs and designed to fit your budget.



# Contents

- 1. Safety Instructions ..... 7**
  - 1.1. General Safety Instructions ..... 7
  - 1.2. Cautionary Notes Regarding Installation ..... 7
- 2. Introduction ..... 9**
  - 2.1. About this Manual ..... 9
  - 2.2. Intended Use ..... 9
  - 2.3. Product Overview ..... 9
    - 2.3.1. Key Components ..... 9
    - 2.3.2. Home Screen ..... 10
    - 2.3.3. Information ..... 11
    - 2.3.4. Electronic Module Connectivity ..... 12
- 3. Installation ..... 14**
  - 3.1. Installation Requirements ..... 14
  - 3.2. Installation Instructions ..... 14
    - 3.2.1. Tools ..... 14
    - 3.2.2. Installing the Base Plate and the Lower Post ..... 14
    - 3.2.3. Installing the Extension Post (optional) ..... 14
    - 3.2.4. Installing the Upper Post ..... 15
    - 3.2.5. Installing the Display Kit ..... 15
    - 3.2.6. Installing the Electronic Module ..... 17
    - 3.2.7. Installing the Weighing Scale (Optional) ..... 18
    - 3.2.8. Leveling the Base Plate ..... 18
    - 3.2.9. Powering on ..... 19
    - 3.2.10. Powering the Device for First Use ..... 20
- 4. Operation ..... 22**
  - 4.1. Measurement Capabilities ..... 22
    - 4.1.1. Definition of Dimensions ..... 22
    - 4.1.2. Object Types ..... 22
  - 4.2. Performing a Measurement ..... 22
    - 4.2.1. Measuring an Object ..... 22
    - 4.2.2. Zeroing Height ..... 23
    - 4.2.3. Switching Unit ..... 24
    - 4.2.4. Transmitting Data ..... 25
    - 4.2.5. Capturing Images ..... 25
    - 4.2.6. Quick Accessing to Logs ..... 26
    - 4.2.7. Quick Access to Alibi Memory for Europe ..... 27
- 5. Setup and Configuration ..... 28**
  - 5.1. Menu Setting ..... 28

5.1.1.	Entering Menu Setting .....	28
5.1.2.	Exiting Menu Setting .....	28
5.1.3.	Menu Structure Overview .....	29
5.1.4.	General Settings .....	30
5.2.	Calibration .....	39
5.2.1.	Autosense Zone .....	39
5.2.2.	Dimensioner Calibration .....	40
5.3.	Accessing the Dimensioner Via the Network.....	42
5.3.1.	Connecting to a Network with DHCP .....	42
5.3.2.	Connecting to a Network with a Fixed IP Address .....	43
5.3.3.	Testing the Network Connection .....	45
<b>6.</b>	<b>Service and Maintenance .....</b>	<b>47</b>
6.1.	Maintenance .....	47
6.2.	Storage .....	47
6.3.	Disposal .....	47
6.4.	Upgrading Firmware .....	47
6.4.1.	Recommended Backup Prior to Firmware Upgrade.....	47
6.4.2.	Firmware Upgrade of Communication Board .....	48
6.4.3.	Software Upgrade of Main Board .....	50
<b>7.</b>	<b>Advanced Troubleshooting .....</b>	<b>52</b>
<b>8.</b>	<b>Spare Parts .....</b>	<b>53</b>
<b>9.</b>	<b>Appendix.....</b>	<b>54</b>
9.1.	Technical Data .....	54
9.2.	Dimension Drawings .....	55





# 1. Safety Instructions

- Read this manual carefully before operating or servicing the device.
- Strictly observe this manual and save it for future use.

## 1.1. General Safety Instructions

- This product is classified as a Class 1 laser product under the EN/IEC 60825-1, Edition 3 (2014) internationally and IEC60825-1, Edition 2 (2007) in the US.
- This product complies with US FDA performance standards under 21 CFR 1040.10 for laser products except for deviations pursuant to Laser Notice No. 50 dated June 24, 2007.
- Explanatory Label is as follow:

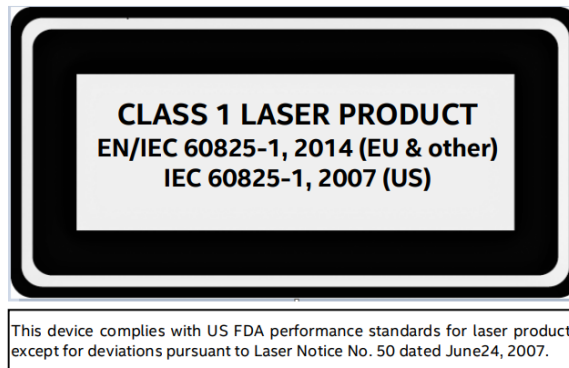

- Risk of electric shock hazard!
- Use only the power adapter delivered with the product.
- Never short-circuit the power adapter or the device.
- Never use damaged power cords or plugs or loose electrical sockets.
- Never touch the power cord with wet hands.
- Always disconnect power cord from the main power before performing any work on the device.
- After connecting the power cord at the AC outlet, press the power button on the electronics module for 1-2 seconds, Unit will power up after 5-10 seconds.
- Handle cables and cable connectors with care.
- Do not allow inexperienced persons to operate this unit.
- Do not use this product if any of the components are cracked.
- Do not make alterations or modifications to the unit.
- Do not remove or obscure labels.
- Operate between 32–95° F (0–35° C).
- Keep the unit dry. Do not use near water, avoid contact with excessive moisture.
- Retain packaging. When transporting the unit, always disassemble and pack it in its original packaging.
- Never modify or attempt to repair the unit. Refer to qualified service personnel for service.
- Never use the product for anything other than its intended purpose.

## 1.2. Cautionary Notes Regarding Installation

- Mount on a flat surface.
- Never drop or allow an impact on the camera head.
- Ensure that the base plate and post assembly are all securely attached before attempting to move the unit.
- Structural parts may be heavy for some personnel. Please follow local safety requirements on

proper lifting techniques.

- It is recommended to assemble the unit on the floor to allow easy access to all parts during assembly. After assembly, the unit can be transported to a final location with assistance.
- Due to the device's layout, the center of gravity is offset.
- Lift gently so you do not lose balance.

## 2. Introduction

### 2.1. About this Manual

This manual contains information about operating, and maintaining the dimensioner, as well as all requirements necessary for the safe use of the system. For more information about this product, please visit [www.mt.com/TLD250](http://www.mt.com/TLD250).

This manual applies to the following product:

- TLD250

### 2.2. Intended Use

The TLD250 Static Dimensioning System is a “Built-for-purpose” measuring instrument that dimensions parcels and packages in post offices, sorting facilities, distribution centers, and warehouses. The TLD250 main firmware has a legally relevant software portion and a non-legally relevant portion. Any other type of use and operation beyond the limits of TLD250 technical specifications without written consent from METTLER TOLEDO is considered as not intended.

### 2.3. Product Overview

#### 2.3.1. Key Components

The TLD250 offers three model heights to accommodate installation preferences based on camera height in cm. The model heights are TLD250 -136, TLD250 -156, and TLD250-176, and consist of the following components:

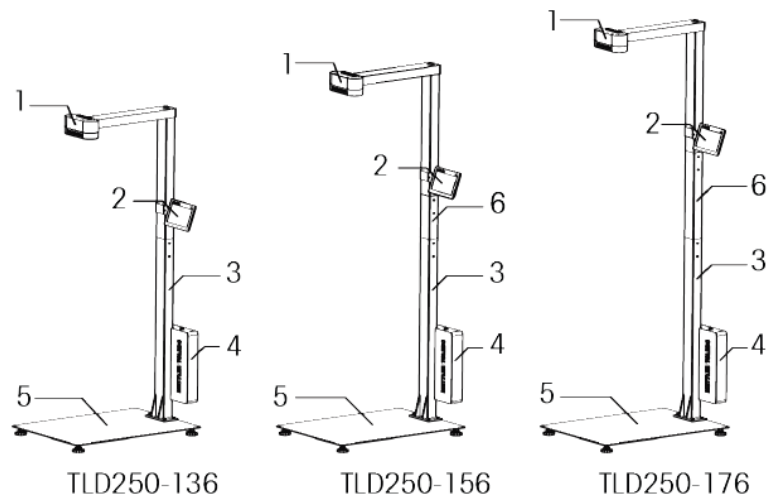

No.	Description
1	Upper post (with camera)
2	Display kit
3	Lower post
4	Electronic module
5	Base plate
6	Extension post <ul style="list-style-type: none"><li>• Length 20 cm for TLD250-156</li><li>• Length 40 cm for TLD250-176</li></ul>

## 2.3.2. Home Screen

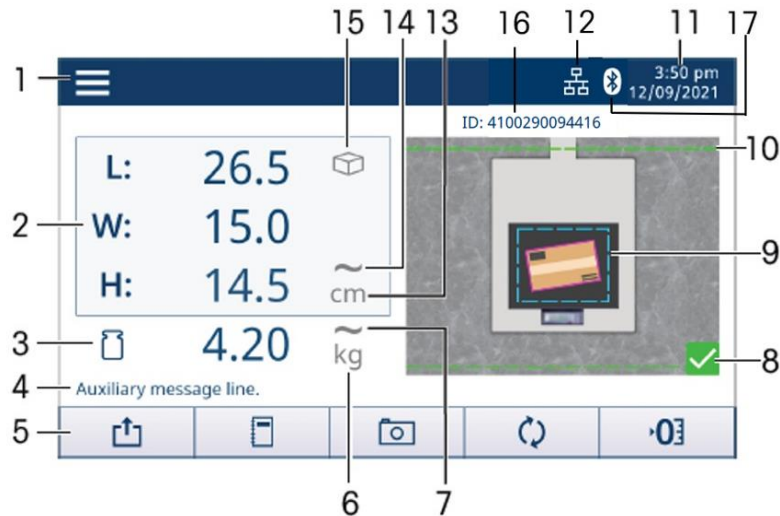

- 1 Setup
- 2 Dimensioning results
- 3 Weighing results
  - Weight
  - Dimensional weight
  - Billable weight
- 4 Auxiliary message line
- 5 Soft keys
  - TRANSMIT
  - LOG
  - CAPTURE
  - SWITCH
  - ZERO HEIGHT
- 6 Weight unit
- 7 Weight motion
- 8 Capture saved
- 9 Autosense Zone
- 10 Measurement boundary
- 11 Date and time
- 12 Connection status
- 13 Dimension unit
- 14 Dimension motion
- 15 Object type
  - Cuboidal
  - Non-cuboidal
- 16 Bar code
- 17 Bluetooth

To transmit data.

To show the measuring record.

To manually capture the top image of the object on the base plate.

To switch between primary and secondary dimensioning unit.

To set the height to zero.

Appears when the weighing scale is in motion.

Appears when the image of the object is successfully saved.

An object that falls in the zone is detected for dimensioning.

Appears when the measurement is in motion.

### 2.3.3. Information

On the home screen, press Setup , then select **Information** to display the available information options.

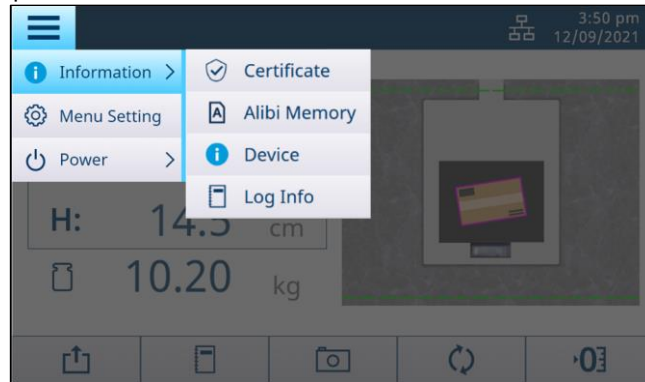

#### 2.3.3.1. Certificate

Press **Information > Certificate** to display the certified measurement specifications of the device.

**Note:** the measurement specification is different based on the certificate.

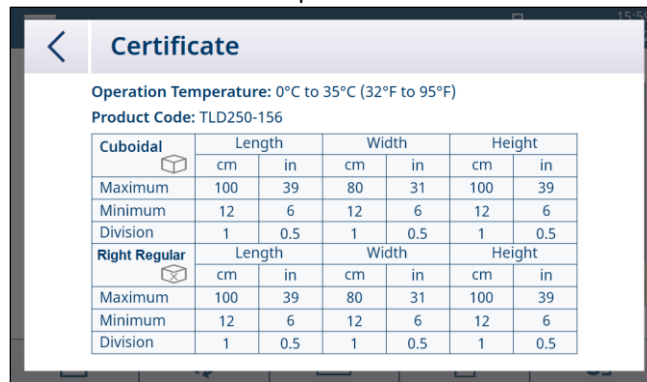

#### 2.3.3.2. Device

Press **Information > Device** to display the device information regarding model, serial numbers, software version, communication, and service support.

**Note:** The identification number of the main firmware is in the format of: A.BC.abc.xyz (ex: 2.00.166.124). The upper-case A.BC (ex: 2.00) indicates the legally relevant portion of the software.

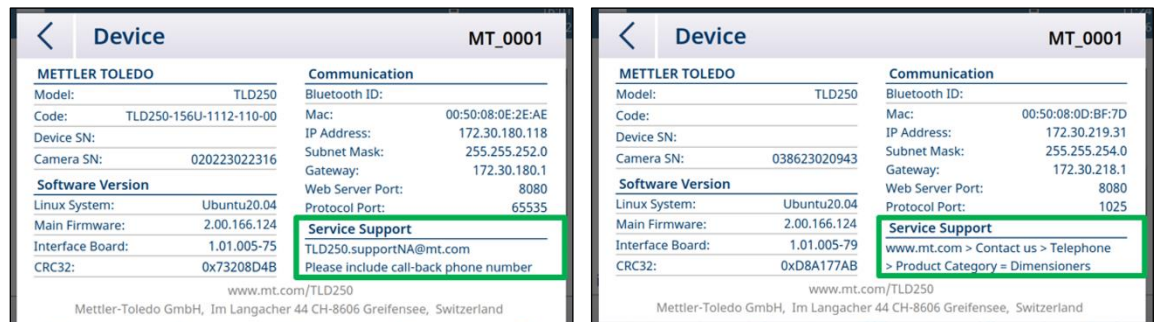

For service support in North America, please send email to [TLD250.supportNA@mt.com](mailto:TLD250.supportNA@mt.com) for call back.

For service support in other areas or countries, visit [www.mt.com](http://www.mt.com) > Contact Us > Telephone and Address Contents for Sales and Service > Product Category = Dimensioners for additional service information.

### 2.3.3.3. Alibi Memory

Press **Information** > **Alibi Memory** to display Alibi data.

There are 3 ways to indicate that the transaction is completed. One of these will trigger to store Alibi Data into TLD250 automatically.

1. Operator presses the transmit softkey  on TLD250 touch screen or 0271 display
2. Operator scans barcode successfully when Metro Lock is enabled
3. PC sends command "D", "DIM" or "CRLF" to TLD250 according to the corresponding protocol

The information of Alibi memory as read-only data stores the ID number, Timestamp, Dimensions, Unit, Cuboidal (Yes/No), Barcode and Checksum for the completion of each transaction.



ID	Date / Time	L	W	H	Unit	Cuboidal	BarCode	Checksum
176	2023-08-17 13:58:13	11.0	6.4	7.8	in	Yes		B332EAB6
175	2023-08-17 13:58:08	11.0	6.4	7.8	in	Yes		6E4F0A48
174	2023-08-17 13:58:06	11.0	6.4	7.8	in	Yes		4ECDFCE3
173	2023-08-17 09:21:42	10.6	6.6	7.8	in	Yes		8657C5A1
172	2023-08-17 09:21:41	10.6	6.6	7.8	in	Yes		AF9F7153
171	2023-08-17 09:21:39	10.6	6.6	7.8	in	Yes		FC1E9257
170	2023-08-17 09:21:37	10.6	6.6	7.8	in	Yes		DC9C64FC
169	2023-08-16 15:41:09	10.8	6.2	8.0	in	Yes		7113890F
168	2023-08-16 13:19:56	10.8	6.2	8.0	in	Yes		5B8D95A3
167	2023-08-16 13:19:54	10.8	6.2	8.0	in	Yes		DC2DB0C0







Page: < 1 / 18 > Count: 176

Alibi memory will be able to store 80,000 items. It is implemented as a circular FIFO, when Alibi memory is full, the new data overwrites the oldest data.

### 2.3.3.4. Log Info

The measurement information of the measured objects is automatically recorded, press



**Information** > **Log Info** to look through the logs. Select one item and press  on the top right, to see the object image when it is available. Click  to delete logs and photos accordingly.

ID	Date / Time	L	W	H	Unit	WT	Unit	Cuboidal	Photo
01	2023-08-17 13:58:13	11.0	6.4	7.8	in	0.266	kg	Yes	
02	2023-08-17 13:58:08	11.0	6.4	7.8	in	0.265	kg	Yes	
03	2023-08-17 13:58:06	11.0	6.4	7.8	in	0.265	kg	Yes	
04	2023-08-17 09:21:42	10.6	6.6	7.8	in	0.266	kg	Yes	
05	2023-08-17 09:21:41	10.6	6.6	7.8	in	0.266	kg	Yes	
06	2023-08-17 09:21:39	10.6	6.6	7.8	in	0.266	kg	Yes	
07	2023-08-17 09:21:37	10.6	6.6	7.8	in	0.266	kg	Yes	

Delete Logs and Photos

Delete Photos

Date  All  Customization





**Note:** This log page displays the last 100 measurements. To find more or download the logs, please connect to the TLD250 web server. The system can record up to the last 10,000 logs.

### 2.3.4. Electronic Module Connectivity

The electronic module of the TLD250 provides the following interfaces for connection of power,

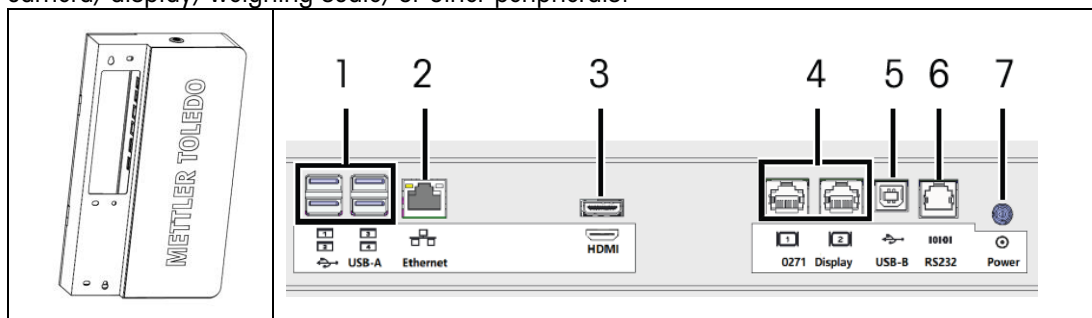
camera, display, weighing scale, or other peripherals.



**Note:** Image of connector on label shows the port orientation. RJ45/RJ12 connectors have a clip tab, USB has a heavy dark line where plastic insert is for the USB-A connector.

No.	Description
1	USB type A: for connection of <ul style="list-style-type: none"> <li>• TLD250 camera</li> <li>• O272 color touchscreen display</li> <li>• Weighing scale (configured as USB-HIDPOS)</li> <li>• Barcode scanner</li> </ul>
2	Ethernet, for PC/Host communications
3	HDMI: for connection of O272 color touchscreen display
4	O271 display interface
5	USB, type B, for PC/Host communications
6	RS232, for PC/Host communications
7	Power port: To connect the power adapter

## 3. Installation

### 3.1. Installation Requirements

- Avoid installation of the device near direct sunlight or near bright lights.
- Protect the device from static electricity and connect to a clean AC power outlet.
- Install the device on a table or sturdy level work surface large enough for the base plate and scale.
- Ensure the location provides enough work surface, clear from other objects in the measurement area.

### 3.2. Installation Instructions

Follow the instructions below or watch the "How-to-video-TLD250" to install the device. Find the installation video on the link of <https://www.mt.com/TLD250>.

#### 3.2.1. Tools

- 5 mm Allen key (provided with the product)
- Phillips screwdriver
- 16 mm open-end wrench, or adjustable wrench

#### 3.2.2. Installing the Base Plate and the Lower Post

1. Place the base plate to the installation location which meets the requirements in Installation Requirements.
2. Fasten the lower post to the base plate with four M6 screws. Tool: 5 mm Allen key.



#### 3.2.3. Installing the Extension Post (optional)

The measuring capability of the device depends on the height of the camera view. To achieve measuring capability (see Technical Specifications) of the following model:

**TLD250-136** Do not install the extension post.

**TLD250-156 (Recommended)** Install the extension post of 20 cm in length (delivered with the product).

**TLD250-176** Install the extension post of 40 cm in length.

- Insert the extension post to the lower post and fasten it with four M4 flat-head screws. Tool: Phillips screwdriver.





### 3.2.4. Installing the Upper Post

1. Insert the camera cable into the lower post.
2. Fasten the upper post to the lower post with four M4 flathead screws. Tool: Phillips screwdriver.



### 3.2.5. Installing the Display Kit

1. Partially fasten the display bracket to the U-shape bracket with one M4 pan-head screw, then rotate the U-shape bracket 180 degrees. Tool: Phillips screwdriver.



2. Slide the U-shape bracket onto the post, then rotate the display bracket back 180 degrees to match up the second screw hole.
3. Fasten the second M4 screw, then tighten both screws. Tool: Phillips screwdriver.



4. Remove the split cable bushing on the hole of the post, and then insert the display cables into the post.

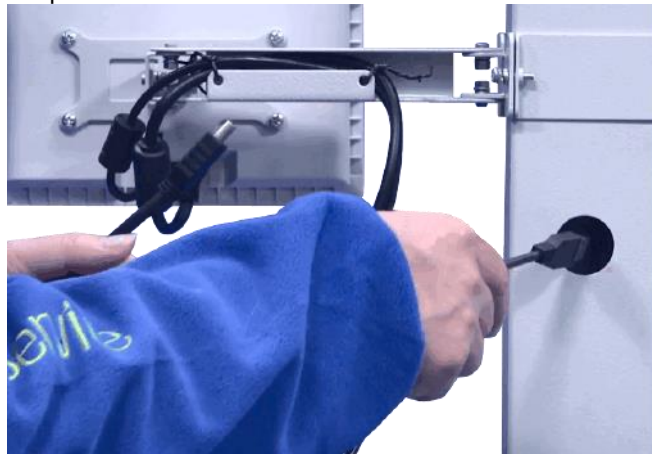

5. Organize the cables with the split cable bushing, and then attach the split cable bushing to the hole.



### 3.2.6. Installing the Electronic Module

1. Unlock the door of the electronic module.
2. Hang the electronic module onto the two holding pins at the rear of the lower post.



3. Fasten the electronic module with four M4 pan-head screws. Tool: Phillips screwdriver.



4. Connect the camera and display cables to the USB and HDMI interfaces.



### 3.2.7. Installing the Weighing Scale (Optional)

If a weighing scale is to be used with the device, following the instructions below to install and connect the weighing scale.

1. Place the weighing scale on the base plate.
2. Choose one of the following mode to connect the device and the weighing scale to the host computer or shipping management system.
  - Mode A: Connect the weighing scale to TLD250's USB port, then connect TLD250 to the host computer or shipping control system.
  - Mode B: Connect the weighing scale and TLD250 separately to the host computer or shipping management system.

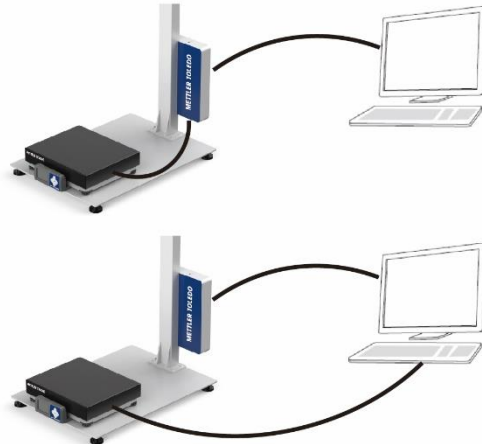

### 3.2.8. Leveling the Base Plate

1. Adjust the foot at each corner of the base plate until the base plate is level.
2. Tighten the nut to lock the foot at each corner. Tool: 16 mm open-end wrench or adjustable wrench.



### 3.2.9. Powering on

1. Connect the power cable connector to the port which has the label of "Input 12V". **NOTICE: Make sure that the power cable is routed through the opening cut at the bottom of the electronic module and is not pinched by the door.**



2. Lock the door of the electronic module.
3. Connect the power cable to an AC outlet. **NOTICE: Power requirement: 100 - 240 VAC, 50 - 60 Hz.**
4. Press the power button on the top of the electric control box.



### 3.2.10. Powering the Device for First Use

If it is the first time to use the device, follow the instructions below to set it up after powering on.

1. After powering on, the display lights up and then enters the Bootup Wizard screen.

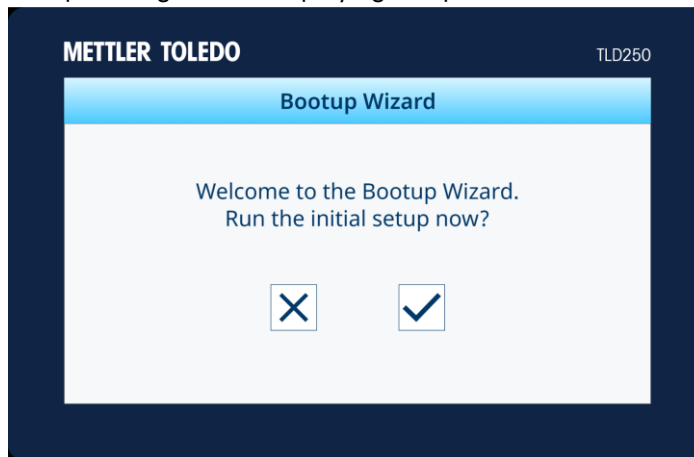

2. Press ✓ to start initial setup and continue at step 3 or press X to enter the home screen.
3. Setup the date & time, communication protocol, and base type by following the instructions on the screen.
4. When done, press ✓ to confirm to reboot.

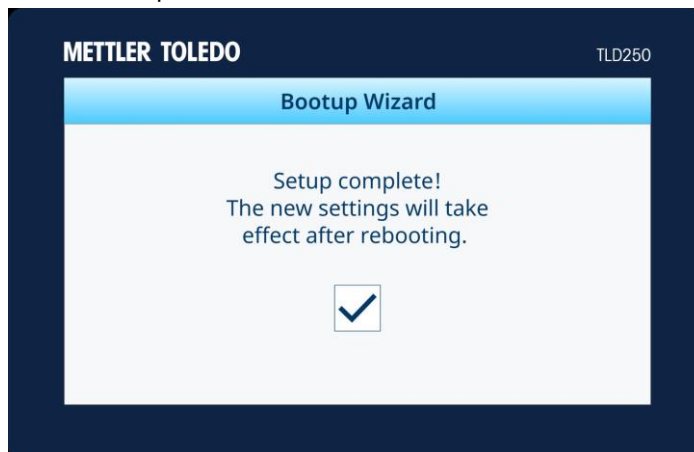

5. The display automatically reboots, then enters the home screen.

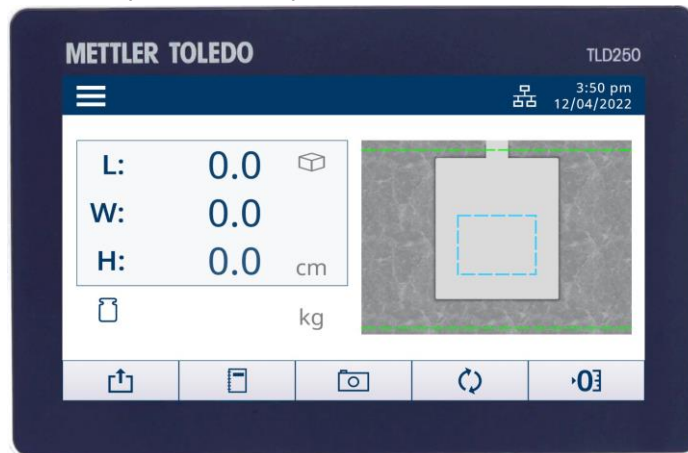

## 4. Operation

### 4.1. Measurement Capabilities

#### 4.1.1. Definition of Dimensions

When reporting dimensions of an object, the device defines length, width and height as follows:

- Length – the longer of the two horizontal measurements
- Width – the shorter of the two horizontal measurements
- Height – the vertical measurement

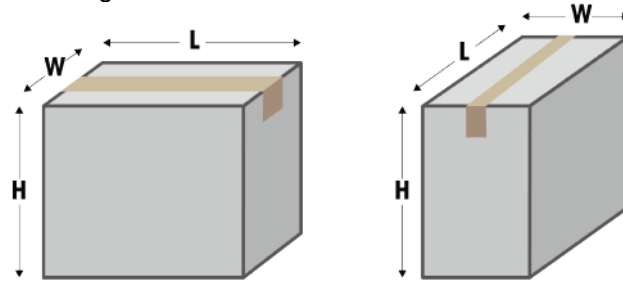

The measurement capability depends on the specific model of the device. Refer to **Technical Data** for more information.

#### 4.1.2. Object Types

The device is designed to measure dimensions of both cuboidal and irregular (or non-cuboidal) shaped objects. Irregular shaped objects are dimensioned as the smallest cube around the shape, and the achieved irregular shapes include cylinders, polygon, donut, tubes, stacked or combined cuboidal objects.

## 4.2. Performing a Measurement

### 4.2.1. Measuring an Object

1. To measure dimensions of an object, make sure that the dimension values show zero before placing parcel in the Autosense zone, perform a ZERO HEIGHT operation if necessary. If a weighing scale is connected to the device, it should be at zero weight.

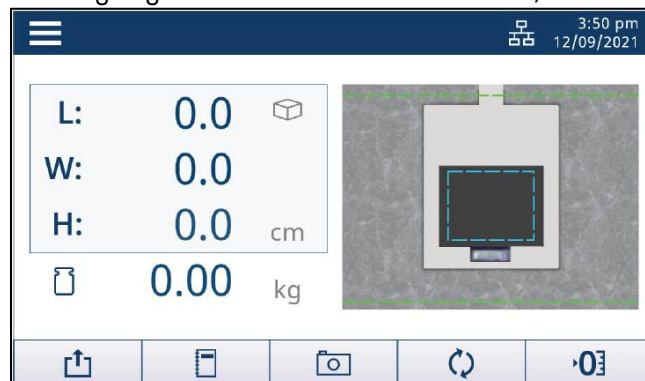

2. Place the object on the base plate or the weighing scale, within the Autosense zone, (blue box - dashed line). Wait until the motion symbol disappears.

**Note:** Autosense Zone must be within the boundaries of the weight scale platter. Weight scale may move slightly with use. Reposition the scale if the "blue box" is not within the scale platter or alter the Autosense zone.





Dos and don'ts for placing an object.

- The object must be placed completely within the measurement boundary (Green line).
- The object can be placed completely or partially where the center of parcel is in the Autosense Zone (Blue line).  
Center of object (Red dot) should be within the autosense zone.
- For the width, the object must be at least 5cm (2") from the lower post flange (solid Blue area in front of Post).

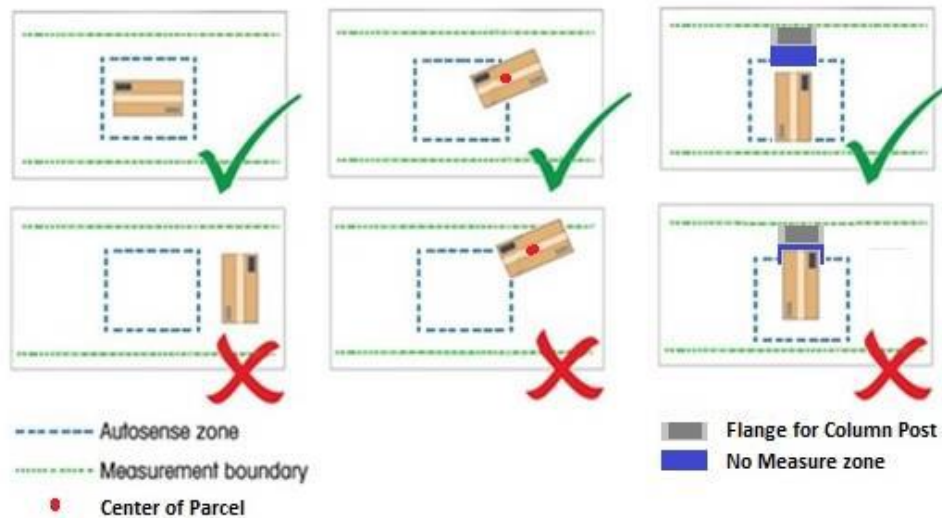







#### 4.2.2. Zeroing Height









If the distance between the camera and the base plate is changed, e.g., when a scale is added or removed, it is necessary to perform a ZERO HEIGHT operation.



### Perform zero height adjustment for a flat base

1. On the home screen, press the ZERO HEIGHT button .
2. The message "Are you sure to zero the height?" appears. Press  to continue (or press  to abort).
3. If the zero height operation is successful, the message "Zero height success" appears. Press  to confirm.
- or -
4. If the zero height operation is unsuccessful, the message "Zero height failed. Would you like to try again?" appears. Press  to repeat (or press  to abort) the zero height operation.

### Perform zero height adjustment for an uneven base

1. On the home screen, press the ZERO HEIGHT button .
2. The message "Are you sure to zero the height?" appears. Press  to continue (or press  to abort).
3. The message "Please place the calibration box on the scale." appears. Follow the instruction and place the calibration box on the top of the scale. Press  to continue (or press  to abort).
4. If the zero height operation is successful, the message "Zero height success" appears. Press  to confirm.
- or -
5. If the zero height operation is unsuccessful, the message "Zero height failed. Would you like to try again?" appears. Press  to repeat (or press  to abort) the zero height operation.



- The base type (flat base or uneven base) is configured during the initial power-up setting or in Menu Setting ► Dimensioner ► Base Type.
- The calibration box can be ordered from METTLER TOLEDO. Refer to **Spare Parts** for ordering information.

## 4.2.3. Switching Unit

To switch between the primary and secondary dimensioning unit, press the SWITCH button  on the home screen.

**Note:** Reference the **Menu Setting > Dimensioner > Unit Switch**, to enable or disable the unit switching functionality, and set the primary and secondary units for the dimensions.

## 4.2.4. Transmitting Data

Data can be transmitted by protocol request command (serial), report request (USB), continuous output, manual transmit or Auto transmit.

- Protocol request, such as serial commands D or DIM are in their specifications.
- Report request are per the USB HIDPOS specifications
- Manual and automatic transmit within the dimensioner are discussed below.

### 4.2.4.1. Transmitting Data Manually

To manually transmit data, press the Transmit button  on the home screen.

**Note:** The Transmit button is disabled when the data is unstable, or the communication is configured as USB-HIDPOS (in **Menu Setting** > **Communication** > **USB**).

### 4.2.4.2. Transmitting Data Automatically

Please configure the Auto-Transmit Mode (in **Menu Setting** > **Communication** > **Auto-Transmit Mode**) as Auto Send or Continuous, so that the data can be transmitted automatically.

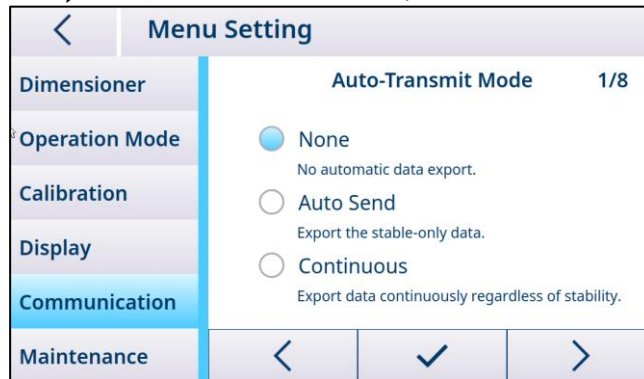

**Note:** It is not required to configure the Auto-Transmit Mode when the communication is configured as USB-HIDPOS (in **Menu Setting** > **Communication** > **USB**).

## 4.2.5. Capturing Images

Setting the image capturing method and the image tag. Up to 10,000 latest images can be saved. To retrieve the images, log onto the TLD250 web server, or use the flash drive download in Maintenance, to export the images.

### 4.2.5.1. Capturing Images Manually

To manually capture the object image, press  on the home screen, then the image of the top side of the object will be saved, when the icon  appears at the lower right corner of the screen.

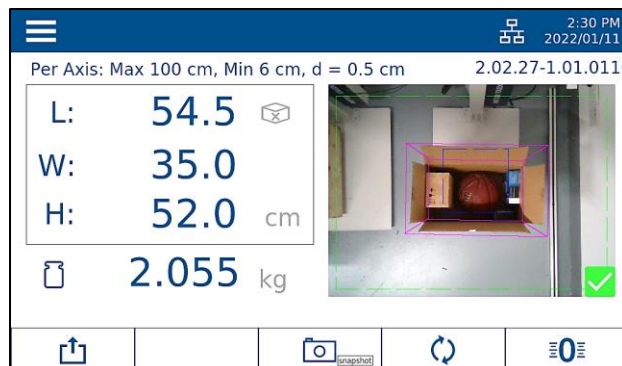

**Note:** The CAPTURE button  is enabled by default in the menu and is effective regardless of the dimension stability. This allows for images to be captured of items packed "inside the box", before packing materials are added, for process order verification if there is a dispute.

**4.2.5.2. Capturing Images Automatically**

The image of the measured object can be automatically captured when its dimensions are stable. The dimensions should go back to zero before the next object image can be captured. These images are typically of the outside of the parcel box for quality verification of the parcel's condition.



**Note:** To enable or disable the image capturing functionality, please access to **Menu Setting > Display > Photos** to change the configuration.

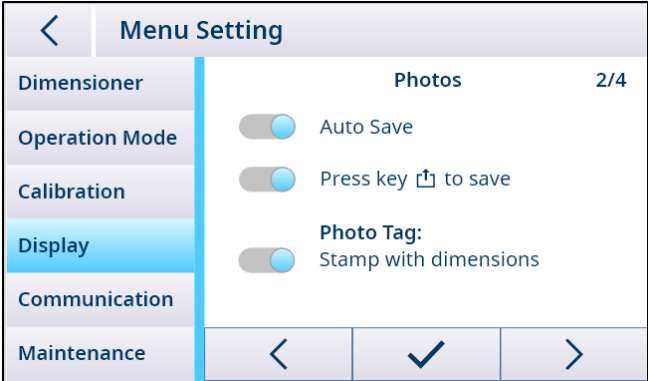

**4.2.6. Quick Accessing to Logs**

For quick access to the measurement logs, press soft key  on the home screen, then the log page will be displayed. For more information, please refer to **Information**.

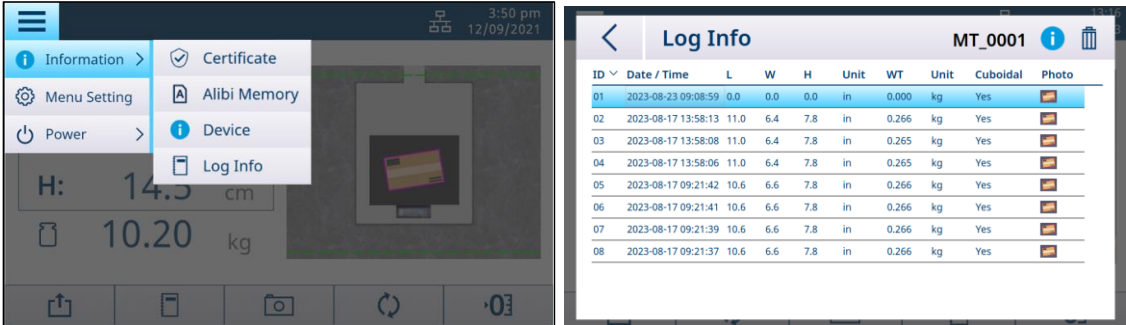

## 4.2.7. Quick Access to Alibi Memory for Europe

For quick access to the Alibi Memory for legal measurement logs, press Setup , then select **Information**, then press Alibi Memory. The Alibi screen will show the logs with 10 per page. Use < or > to shift between pages. If a measurement is Duplicated, it will show a D in the Dupl data Column. The Alibi log is matched with Point of Sale Data by Time stamp. Maximum number of records is 80,000. Data will roll over after 80,000 records. Customer can view the data only on the display. Move bottom slide bar to see checksum column. There is no provision for clearing or deleting the Alibi data.

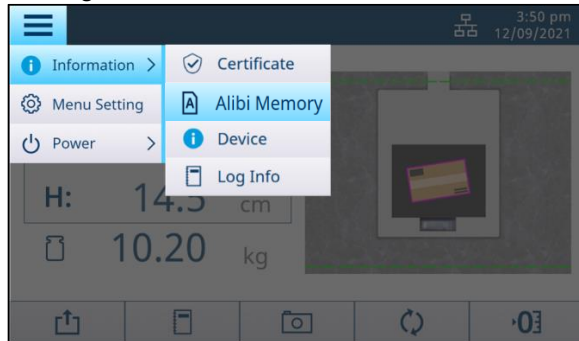

Alibi Memory								
ID	Date / Time	L	W	H	Unit	Cuboidal	BarCode	Checksum
176	2023-08-17 13:58:13	11.0	6.4	7.8	in	Yes		B332EAB6
75	2023-08-17 13:58:08	11.0	6.4	7.8	in	Yes		6E4FOA48
174	2023-08-17 13:58:06	11.0	6.4	7.8	in	Yes		4ECDFCE3
173	2023-08-17 09:21:42	10.6	6.6	7.8	in	Yes		8657C5A1
172	2023-08-17 09:21:41	10.6	6.6	7.8	in	Yes		AF9F7153
171	2023-08-17 09:21:39	10.6	6.6	7.8	in	Yes		FC1E9257
170	2023-08-17 09:21:37	10.6	6.6	7.8	in	Yes		DC9C64FC
169	2023-08-16 15:41:09	10.8	6.2	8.0	in	Yes		7113890F
168	2023-08-16 13:19:56	10.8	6.2	8.0	in	Yes		5B8D95A3
167	2023-08-16 13:19:54	10.8	6.2	8.0	in	Yes		DC2DB0C0

Page: < 1 / 18 > Count: 176

## 5. Setup and Configuration

### 5.1. Menu Setting

The menu setting block allows you to configure the dimensioner, operation mode, display, and communication parameters, etc.



#### 5.1.1. Entering Menu Setting

In the home screen, press the Setup button , then select **Menu Setting**, then the display navigates to the Menu Setting screen shown above.

#### 5.1.2. Exiting Menu Setting

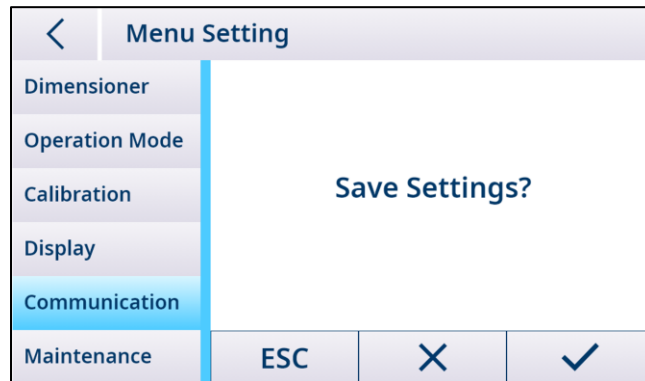
In the Menu Setting screen, press  on the upper left corner, then the following screen appears.



1. Press **ESC** to continue editing the menu settings.
2. Press  to discard menu changes and return to the main screen.
3. Press  to save the menu settings and reboot.

**Note:** In each menu block, it is required to press  to register and acknowledge the expected menu changes before exiting the menu setting. The Dimensioner will not reboot after each menu block is saved.

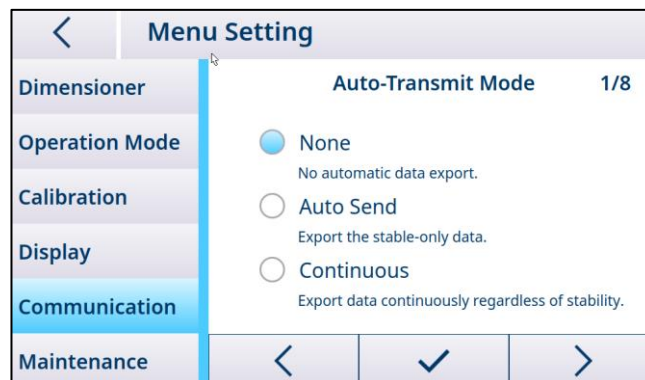

### 5.1.3. Menu Structure Overview

Level 1	Level 2	Level 3	Level 4
<b>Dimensioner</b>	Metro Lock	Enable, Disable	
	Type Approved	Non-approved, NTEP, OIML, MC*	
	Unit Switch	Unit Switch	Enable, Disable
		Primary Unit	mm, cm, in
		Secondary Unit	mm, cm, in
	Base Type	Flat base, Uneven base	
	Object Type	Flats	2.5 cm/1 in, 5 cm/2 in, Disable
		Cuboidal	Enable
		Irregular	Enable, Disable
	Resolution	High, Middle, Low	
	Product Code	TLD-136, TLD-156, TLD-176	
	Decimal Symbol	Decimal, Comma	
	Zero Range	None, 20%, 50%	
	Filter	Normal, High	
	Data Rounding	Normal, Round up, Expand	
Bootup Wizard	Enable, Disable		
Device Reset			
<b>Operation Mode</b>	Data Panel	None, Weight, Dim. Weight (Inc. factor setting), Billable Weight	
<b>Calibration</b>	Autosense Zone		
	Dimensioner Calibration		
<b>Display</b>	Language	English, Chinese*, Portuguese*, Germany*, French*, Spanish*	
	Photos	Auto Save	Enable, Disable
		Press the export key to save	Enable, Disable
		Stamp with dimensions	Enable, Disable
	Soft Keys		
Screen Saver	Disable, 5 mins, 10 mins, 30mins		
<b>Communication</b>	Auto-Transmit Mode	None, Auto Send, Continuous	
	Protocol	CSN810, MT-SICS, Proto U, CS5120, Proto D1, Customer	
	Serial	Baud	1200, 2400, 4800, 9600, 19200, 38400, 57600
		Data Bits	7, 8

<b>Communication</b>		Parity	Space, Mark, Odd, Even, None
		Stop Bits	1, 2
	Ethernet	DHCP	On, Off
		IP Address	
		Subnet Mask	
		Gateway	
		Protocol Port	
	Bluetooth	Enable, Disable	
	USB	HIDPOS, Virtual Serial, Keyboard Wedge (Inc. setting)	
	Scale Setting	USB, TCP	
Web Server	Enable, Disable		
<b>Maintenance</b>	Data & Time		
	Device Check		
	Calibration Prompt	Disable, 3 months, 6 months, 12 months	
	Firmware Upgrade		
	Log and Photos Export	Log, Photos	
	Station Name		
	Menu Lock	Enable, Disable	
	Remote Help	Enable, Disable	

Note: "\*" means not available yet.

## 5.1.4. General Settings

### 5.1.4.1. Dimensioner



<b>Metro Lock</b>	<b>Check with local authorities if your application is Legal-for-Trade. For Legal-for-Trade applications, lock should be enabled to avoid the metrology sensitive settings being changed; For Non-Legal-for-Trade applications, lock could be disabled for easier access to all the menu settings.</b>
Enable	The Metrology Lock is enabled, and the metrology sensitive settings can't be configured.
Disable	<b>Note: For Legal-for-Trade applications, only authorized people can perform the change.</b> To disable the Metrology Lock, please follow the steps below: 1. Access to Menu Setting-Dimensioner, press Metro Lock.

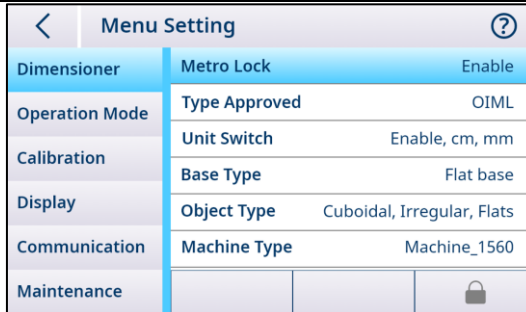



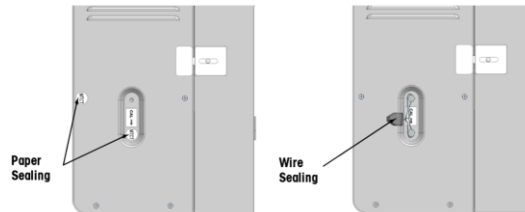

2. Break the sealing on the rear of the electronic module.



3. Short press the calibration button with a thin pin or plastic stylus, then the lock icon  will change to a pencil icon .



4. Access to the Metro Lock setting, and then disable the lock. press  to confirm and then  to save the change and reboot.

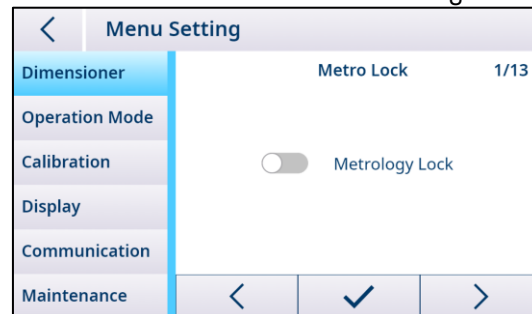

<b>Type Approved</b>	<b>The Type Approved parameters allow selection of the approval criteria.</b>
Non-approved	The device must not be used in legal metrology.
NTEP	NTEP approval.
OIML	OIML approval.

MC	MC approval, not available yet.
<b>Unit Switch</b>	<b>Enable or disable the dimension unit switch functionality. Set the primary and secondary dimension unit.</b>
Unit Switch	If enabled, the TLD250 can switch between the primary and secondary units of measure via the soft key. If disabled, the dimension unit will only be the primary unit.
Primary Unit	Set the primary dimension unit (mm, cm, in).
Secondary Unit	Set the secondary dimension unit (mm, cm, in).
<b>Base Type</b>	<b>Configure the Base Type based on the real application.</b>
Flat Base	For applications with a flat smooth surfaced like the TLD250 base plate, without a scale, or an integrated scale with a flat platter.
Uneven Base	For applications with an uneven base, like a scale platter with a ball top or roller conveyor top.
<b>Object Type</b>	<b>Setting the type of the measurement objects.</b>
Flats	Non-Legal-For-Trade application, if enabled, the measured object height will be shown as a fixed value (2.5 cm/1 in or 5 cm/2 in) when lower than the minimum height.
Cuboidal	Permanently enabled, no option.
Irregular	If disabled, the irregular object will be measured as cuboidal with cuboidal symbol shown.
<b>Resolution</b>	<b>Setting the display resolution of the dimensions.</b>
High	Default, 0.5 cm/0.2 in.
Middle	1 cm/0.5 in.
Low	2 cm/1 in.
<b>Product Code</b>	<b>It requires to set the type of the device, when remove or install an extension post of different height.</b>
TLD250-136	No extension posts installed, the designed camera height is 136 cm.
TLD250-156	The installed extension post is 20 cm, the designed camera height is 156 cm.
TLD250-176	The installed extension post is 40 cm, the designed camera height is 176 cm.
<b>Decimal Symbol</b>	<b>Setting the display format of the decimal point.</b>
Decimal	Example: 50.5
Comma	Example: 50,5
<b>Zero Range</b>	<b>Setting the zero height range.</b>
None	Any height within the camera's field of view.
20%	20% of measurement maximum height. For TLD-136, it is 16 cm; For TLD-156, it is 20 cm; For TLD-176, it is 24 cm.
50%	50% of measurement maximum height. For TLD-136, it is 40 cm; For TLD-156, it is 50 cm; For TLD-176, it is 60 cm.
<b>Filter</b>	<b>Select the dimension measurement filter according to the lighting condition.</b>
Normal	Select "Normal" when the lighting condition is normal.
High	Select "High" when the lighting condition is poor, and it may take longer time to get stable dimensions.
<b>Data Rounding</b>	<b>Setting the rounding method of the measurement values.</b>
Normal	Round by 4/5. Example: 10.2 cm will round to 10.0 cm; 10.3 cm will round to 10.5 cm.

Round up	Dimension values round up; Example: 10.2 cm will round up to 10.5 cm.
Expand	Non-Legal-For-Trade application, the measurement values display one more digit.
<b>Bootup Wizard</b>	<b>Enable or disable the bootup wizard for next boot.</b>
Enable	Enable the bootup wizard for next boot. Note: When the device is used for the first time, the bootup wizard is activated.
Disable	The bootup wizard will be auto disabled after processed.
<b>Device Reset</b>	<b>Reset the menu of the device to factory settings.</b>

#### 5.1.4.2. Operation Mode

<b>Data Panel</b>	<b>Select additional information to show on the data panel.</b>
None	There is no additional information
Weight	To show the object weight on the data panel from the USB weight scale.
Dimensional Weight	To show the dimensional weight on the data panel, as calculated by the TLD250 with the inputted DIM Weight factor. Calculation is feasible for service types where the DIM Weight factor seldom changes.
Billable weight	To show the billable weight, which is the larger of DIM Weight verses actual weight.

#### 5.1.4.3. Display

<b>Language</b>	<b>Setting the display language.</b>
English	Chinese*, Portuguese*, Germany*, French*, Spanish*
<b>Photos</b>	<b>Setting the image capturing method and the image tag. Up to 10,000 latest images can be saved, export to USB flash drive in Maintenance, or log onto the TLD250 web server and export the images.</b>
Auto Save	If enabled, the image of the measuring object will be auto captured when its dimensions are getting stable. <b>Note:</b> Dimensions should return to zero before capturing the next object image.
Press the image-capture key to save	If enabled, the image of the measuring object can be manually captured regardless of stability using the Capture soft key. These photos are saved in a different file folder then the Auto Saved photos.
Stamp with dimensions	If enabled, the object image will be stamped with dimensions.
<b>Soft Keys</b>	<b>Select the soft keys from keys library to show on the home screen.</b>
Zero Height, Unit Switch, Transmit, Log Info Capture	To add or remove the soft keys, please drag the keys between the "Keys library" and "Home page rows". 
<b>Screen Saver</b>	<b>Setting the time of screen saver.</b>
Disable	The screen saver will never appear.

5 mins	The screen saver will appear if there is no activity within 5 minutes.
10 mins	The screen saver will appear if there is no activity within 10 minutes.
30 mins	The screen saver will appear if there is no activity within 30 minutes.

#### 5.1.4.4. Communication

<b>Auto-Transmit Mode</b>	<b>Setting the data auto-transmit mode.</b> <b>Note: It is not applicable for USB-HIDPOS communication.</b>
None	The data can't be transmitted automatically.
Auto Send	The stable-only data will be transmitted automatically.
Continuous	The data will be transmitted automatically regardless of stability.
<b>Protocol</b>	<b>Setting the data transmitting protocol.</b>
CSN810, MT-SICS, Proto U, CS5120, Proto D1 Customer	-
<b>Serial</b>	<b>Setting the parameters of serial communication.</b>
Baud	Available settings: 1200, 2400, 4800, 9600, 19200, 38400, 57600
Data Bits	Available settings: 7, 8
Parity	Available settings: Space, Mark, Odd, Even, None
Stop Bits	Available setting: 1, 2
<b>Ethernet</b>	<b>Setting the parameters of Ethernet communication.</b>
DHCP	Please refer to <b>[chapter 5.3 Network Connection]</b> to do the setting.
IP Address	
Subnet Mask	
Gateway	
Protocol Port	
<b>Bluetooth</b>	<b>Enable or disable the Bluetooth connection.</b>
Enable	Enable the Bluetooth connection. <b>Note:</b> Please confirm that your device type supports Bluetooth connectivity.
Disable	Disable the Bluetooth connection.
<b>USB</b>	<b>Setting the parameters of USB communication.</b>
HIDPOS	If enabled, the device can communicate with the application on the PC via HIDPOS protocol.
Virtual Serial	If enabled, the device can communicate with the application on the PC via serial protocol over a USB cable. But a special software driver is required for the PC, download the driver at <a href="http://www.mt.com/TL250">www.mt.com/TL250</a> .
Keyboard Wedge	If enabled, data is automatically "typed" into any software program from the device. <b>Note:</b> It is available to set your customized export format, and you can enter up to 60 characters.

<b>Scale Setting</b>	<b>Set the communication to scale.</b>
USB	Connect to Mettler Toledo xxx and other USB scale
TCP	Remotely connect to Mettler Toledo Ethernet scale <b>Note:</b> TL250 and Ethernet scale should be connected into same LAN. Ethernet scale should use MT SICS protocol
<b>Web Server</b>	<b>Enable or disable the Web Server function.</b>
Enable	Enable the Web Server function. 
Disable	Disable the Web Server function.

#### 5.1.4.5. Maintenance

<b>Date &amp; Time</b>	<b>Setting the date, time and its display format of the dimensioning system.</b>
Data & Time Format	<div style="border: 1px solid black; padding: 5px; margin-top: 10px;"> <p><b>Note:</b> If using Alibi Memory, set Date and Time to match the Point-of-Sale system.</p> </div>
<b>Device Check</b>	<b>It allows to check the dimension accuracy of the device.</b>
	To check the device, please put on the calibration box, then press “Device Check”.

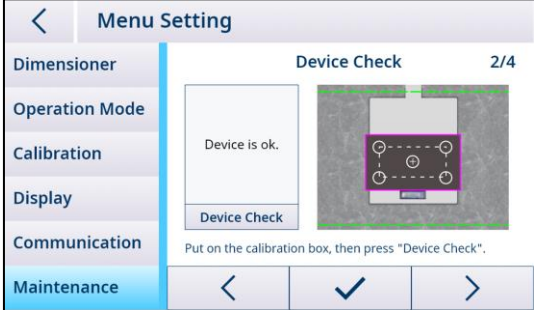
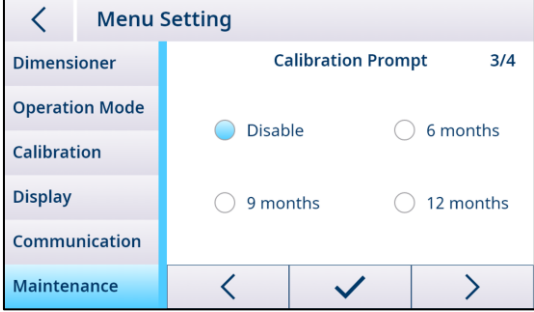
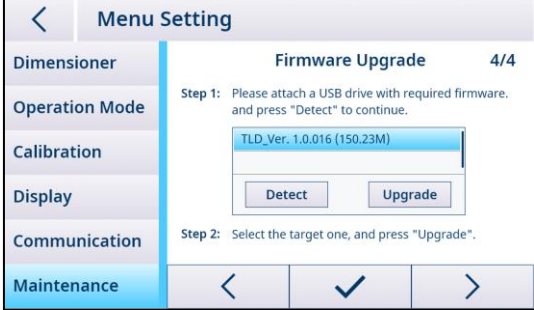
	
<p><b>Calibration Prompt</b></p>	<p><b>The calibration prompt allows a message to remind an operator to do the calibration for the dimensioner after a specified time of use.</b></p>
<p>Disable, 6 months, 9 months, 12 months</p>	
<p><b>Firmware Upgrade</b></p>	<p><b>Upgrading the main board firmware of the device via a USB flash drive.</b></p> <ul style="list-style-type: none"> <li>• Metrology Lock needs to be disabled.</li> <li>• See section <b>6.4.2</b> for the updating of the Communication Interface board.</li> </ul>
	<p><b>Note:</b> If a firmware upgrade is necessary, METTLER TOLEDO will notify the registered customer and will make a version available for download. To upgrade the Main firmware, please follow the steps below:</p> <ol style="list-style-type: none"> <li>1. Please attach a USB flash drive to one of the 4 USB ports, with required firmware, and press detect to continue.</li> </ol> <p><b>Note:</b> Software must be in the root file (not in a folder), and it should be the only version of software.</p>  <ol style="list-style-type: none"> <li>2. After the firmware name is displayed, press "Upgrade" to do upgrade.</li> </ol>

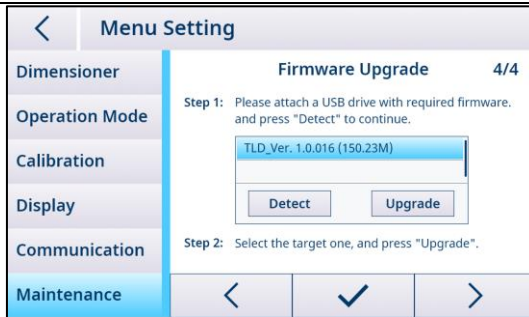

3. Once done, press  to reboot the device.

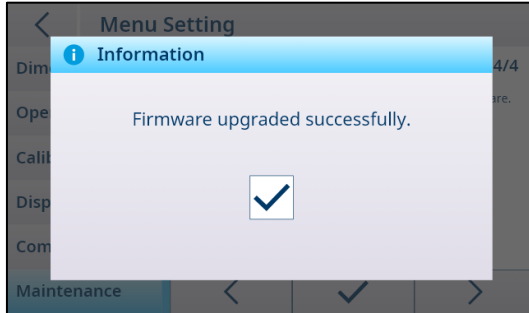

**Log and Photos Export**

**Set the options for exporting log and photos.**

To export log and photos, please follow the steps below:

1. Access to Menu Setting-Maintenance, press Log and Photos Export.

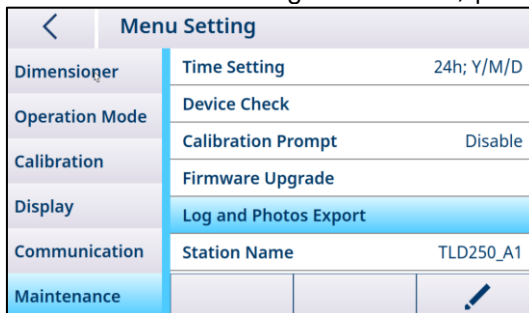

2. Detect the path to export and choose the Log and Photos with the sliders.

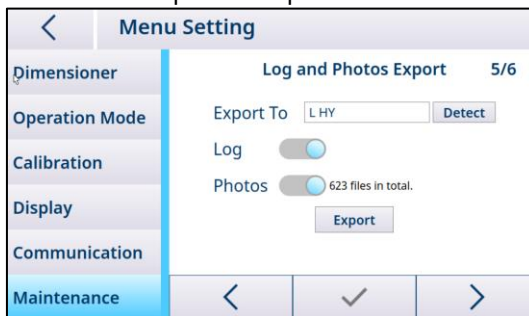

3. Press the "Export". Once done, press  to finish the export.

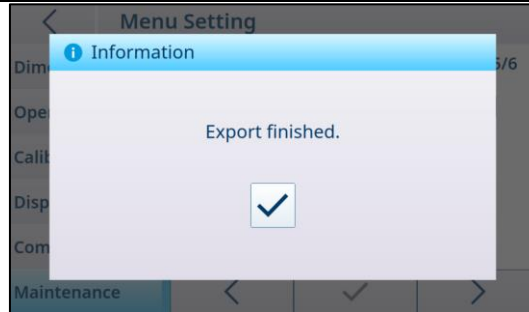

4. A Zip File is created with the Packing Station name and date.
- Automatic Photos will be in the "photos" folder
  - Manual photos will be in the "Snapshot" folder
  - Data log will be the "applog.dat" file

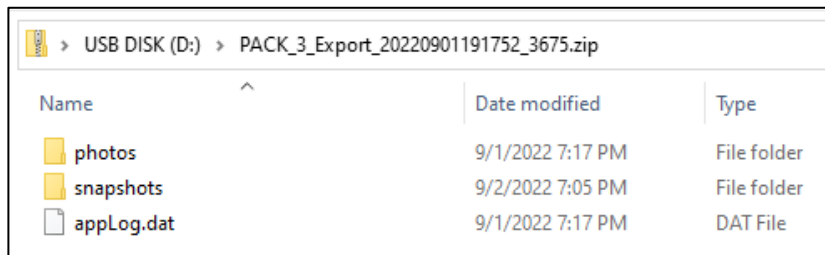

**Station Name**

**Set a dedicated Packing Station name.**

To set a Packing Station name, to identify the TLD250 for Photos and the log, please follow the steps below:

1. Access to Menu Setting-Maintenance, press Station Name.

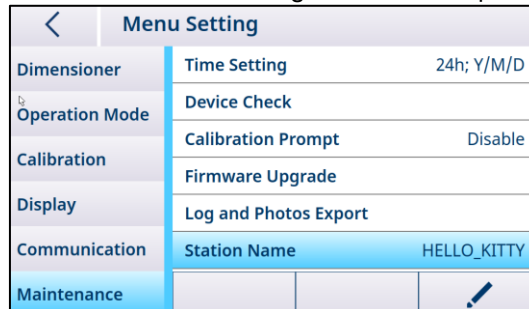

2. Click the edit widget of station name.

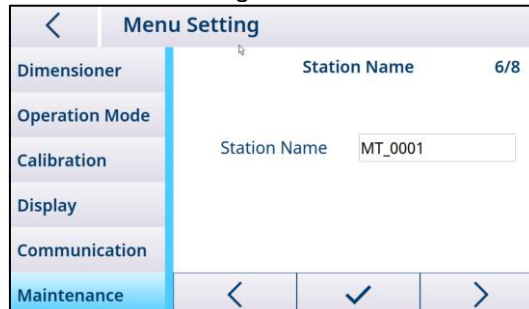

3. Input the station name with the keypad and press  to confirm.

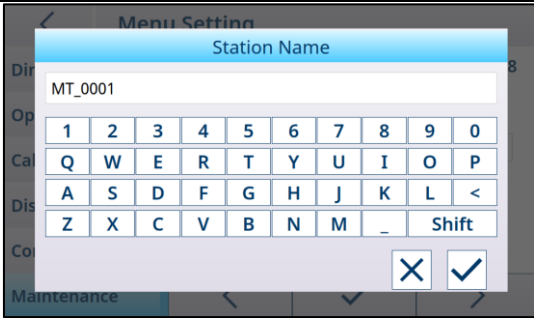
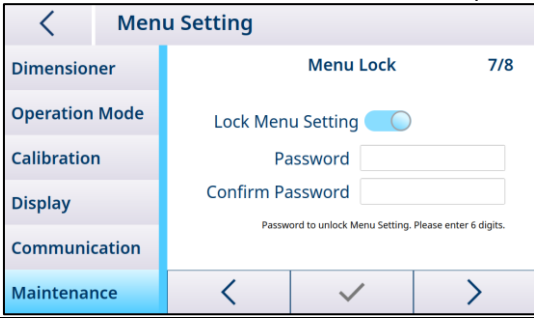
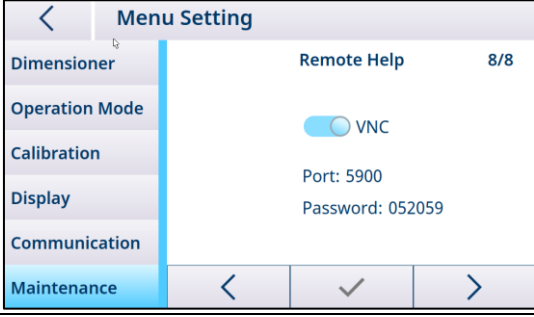

	
<b>Menu Lock</b>	<b>Enable or disable the menu lock function.</b>
Enable	<p>Enable the menu lock function and set a password for unlock.</p> 
Disable	Disable the menu lock function.
<b>Remote Help</b>	<b>Enable or disable the remote help function.</b>
Enable	<p>Input the password to enable remote help.</p> 
Disable	Disable the remote help function.

## 5.2. Calibration

The calibration menu block allows to configure the Autosense Zone and calibrate the dimensioner.  
**Note:** The calibration menu block is accessible only when the Metrology Lock is disabled. (Refer to **Dimensioner**)

### 5.2.1. Autosense Zone

The Autosense Zone represents the detection area to be used for object dimensioning. The object to be measured correctly must be placed at least partially within the Autosense Zone. To change the Autosense Zone, please follow the steps below:

1. Press  and adjust the four dots to create a new zone. Dots will become white when change mode is enabled.

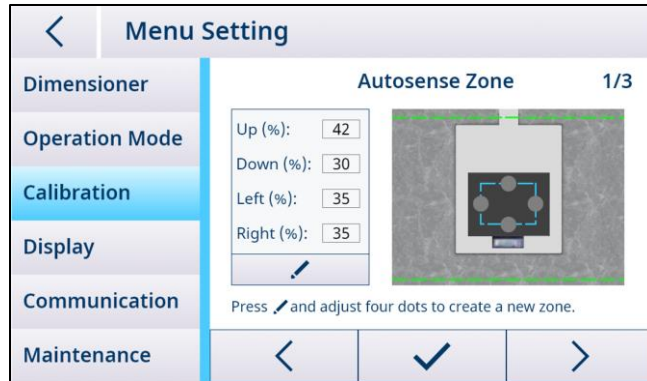

2. Press ✓ to save, and the device will be auto rebooted.

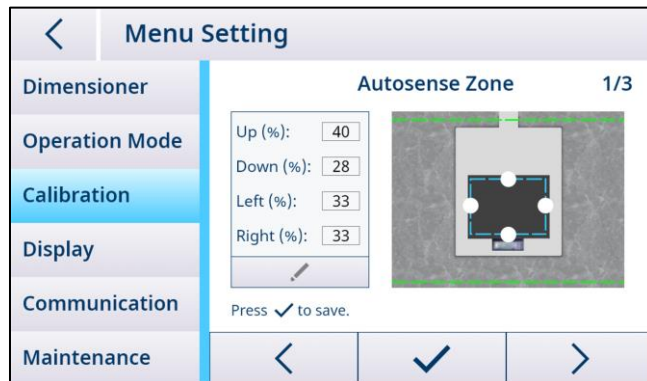

## 5.2.2. Dimensioner Calibration

**Note:** TLD250 is calibrated in the factory prior to shipping. Unlike weight scales, you should not need to initially calibrate the device on site for localization.

The dimensioner calibration process changes with the selection of base type in the menu. To change the base type, please access to the **Dimensioner** > **Base Type** parameter to configure, save and reboot.

For flat base:

1. Clear the base or scale, then press “NEXT” to do zero calibration.

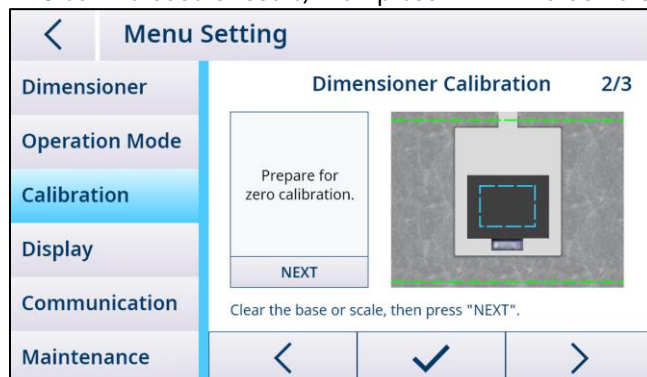

2. When zero calibration succeed, put on the calibration box, then press “NEXT” to do box calibration.

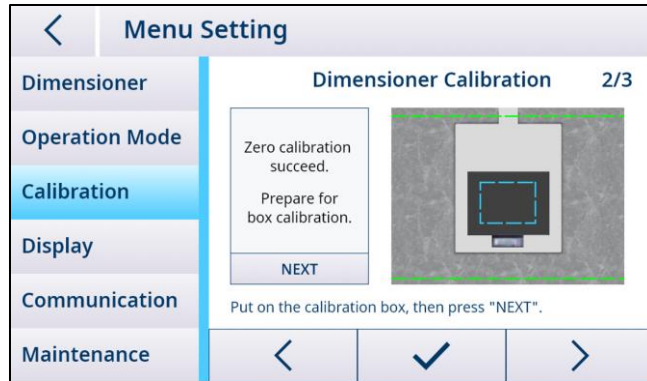

**Note:** If zero calibration failed, please clear the base or scale and try again. if the failure persists, please refer to **[Chapter, Trouble shooting, Zero Height Failed]**.

3. When calibration is completed, then press ✓ to save and the device will reboot automatically.

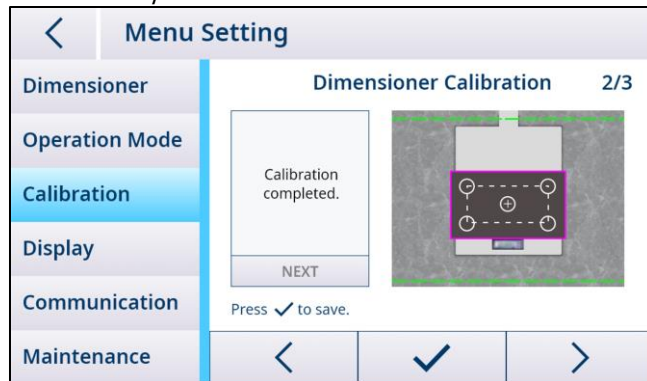

For uneven base:

1. Place the calibration box on the scale, then press **"NEXT"** to do zero calibration.

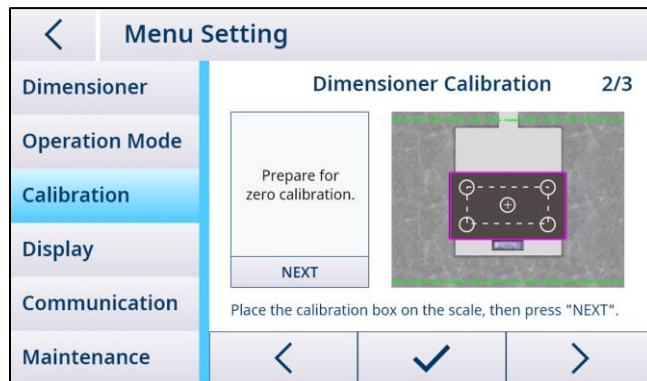

2. When zero calibration succeed, keep the calibration box on the scale, then press **"NEXT"** to box calibration.

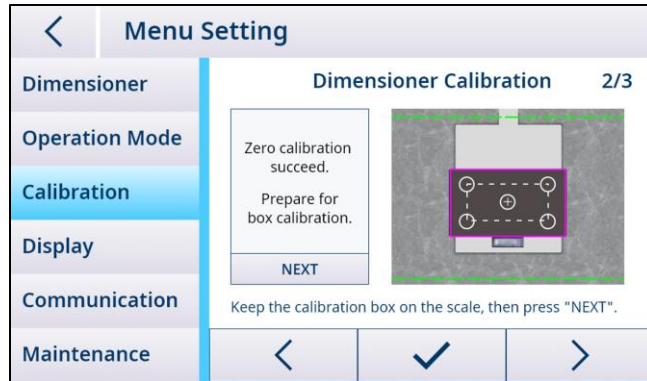

**Note:** If zero calibration failed, please replace the calibration box and try again. If the failure persists, please refer to [Chapter, Trouble shooting, Zero Height Failed].

3. When calibration is completed, then press ✓ to save and the device will reboot automatically.

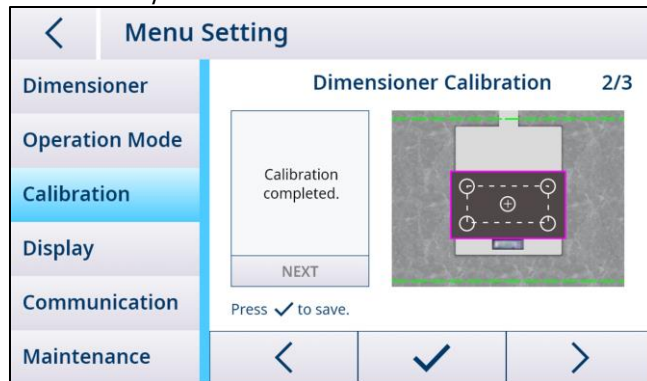

## 5.3. Accessing the Dimensioner Via the Network

### 5.3.1. Connecting to a Network with DHCP

Usually, the IP address on a network is assigned by a DHCP server (Dynamic Host Configuration Protocol). To enable the DHCP mode on the dimensioner, please follow the steps below:

1. Access to **Menu Setting** > **Communication** > **Ethernet**, then press ✎.

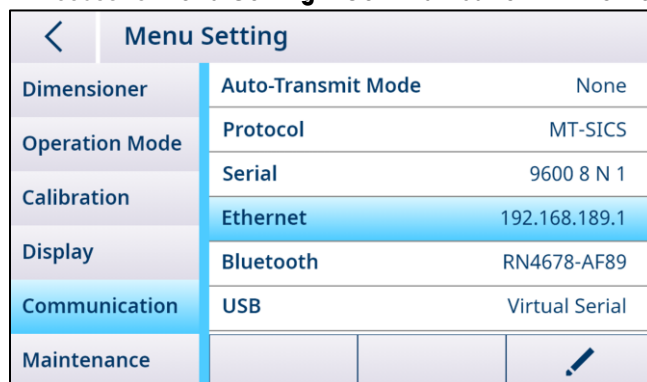

2. Select "On" for DHCP, then the dimensioner is automatically assigned an IP address by the DHCP server. Protocol Port is also configurable, and the range is between 1024 and 65535.

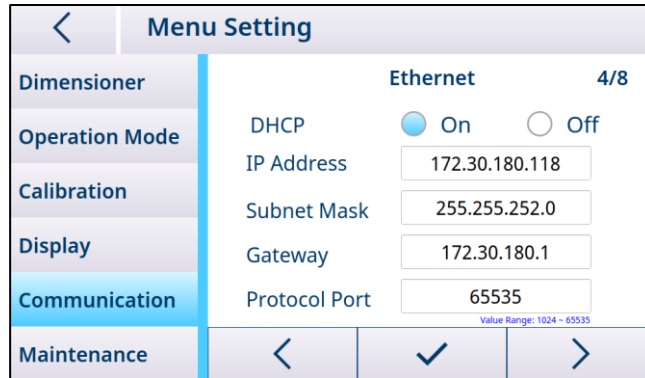

3. Press to confirm and then to save and reboot.

## 5.3.2. Connecting to a Network with a Fixed IP Address

The following settings must be made to connect the dimensioner to a network with fixed IP addresses.

### 5.3.2.1. Configuring Network on a PC

1. Open the Network and Sharing Center (**Start > Control Panel > Network and Internet > Network and Sharing Center**) on your PC, then click "Ethernet".

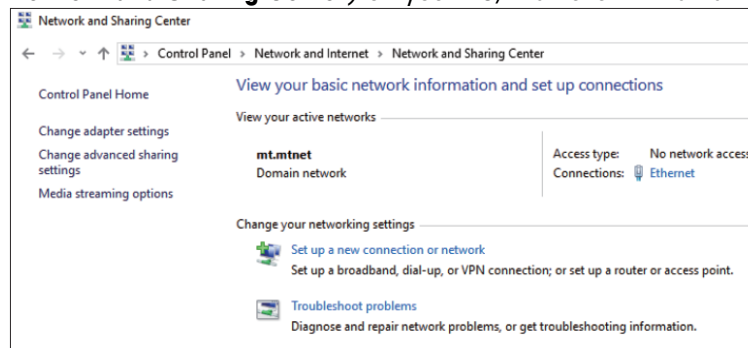

2. Click "Properties" in the Ethernet Status window.

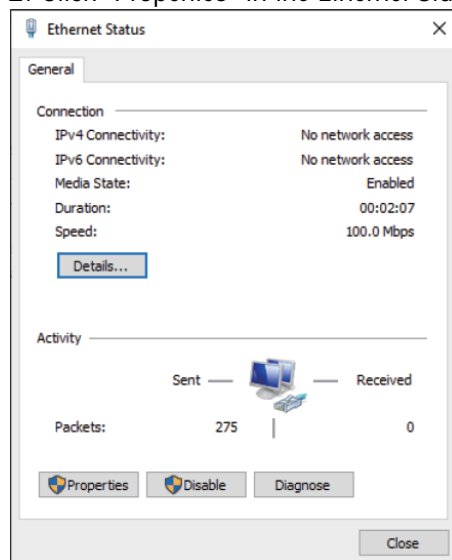

3. Select "Internet Protocol Version 4 (TCP/IPv4)" in the Ethernet Properties window.

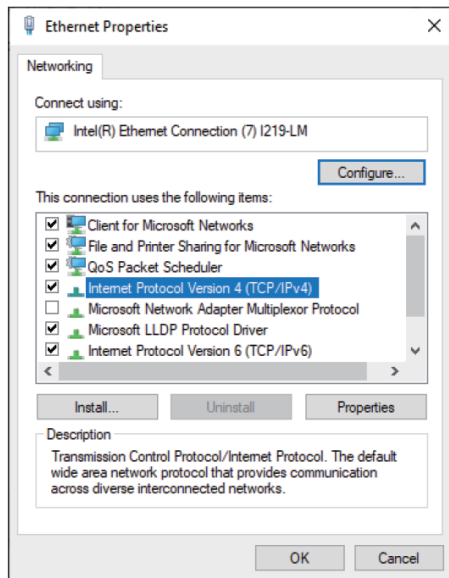

4. Click "Properties" and select "Use the following IP address", enter the IP address, then click "OK".

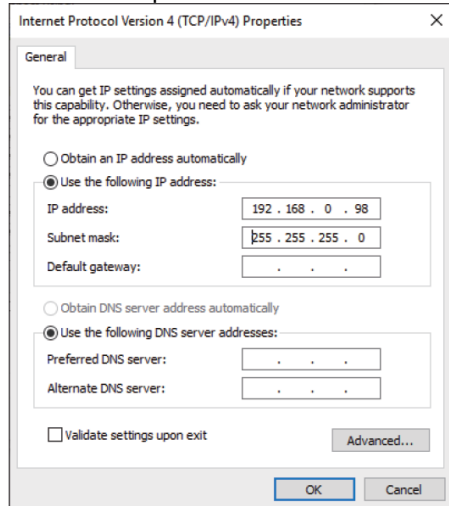

5. Click "OK" to close the following window.

### 5.3.2.2. Configuring Network on the Dimensioner

1. Access to Menu Setting-Communication-Ethernet, then press .

Menu Setting		
Dimensioner	Auto-Transmit Mode	None
Operation Mode	Protocol	MT-SICS
	Serial	9600 8 N 1
Calibration	Ethernet	192.168.189.1
	Bluetooth	RN4678-AF89
Communication	USB	Virtual Serial
Maintenance		

2. Select "Off" for DHCP, then enter a unique IP address following the same address subnet as the

PC.

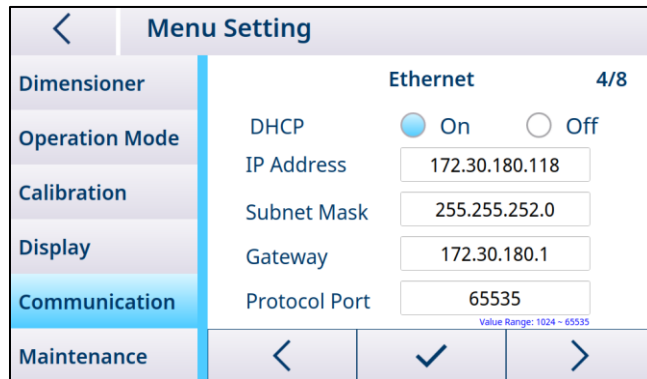

**Note:** Do not use the same IP address as the PC. Last digit should be different. (99 verses 98)

3. Press ✓ to confirm and then < to save and reboot.

### 5.3.3. Testing the Network Connection

#### 5.3.3.1. "Ping" Command

To check whether the network connection is working properly, do as follows:

1. Enter "cmd" in the input area of the start menu of your PC.

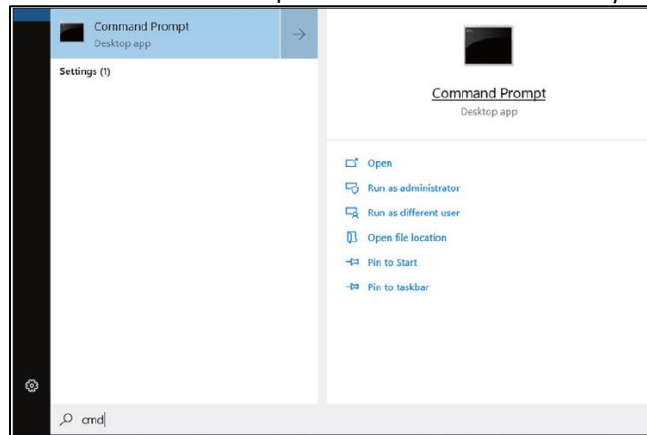

2. Enter "ping" in the Command Prompt followed by a space and the IP address of the dimensioner, then confirm with "Enter".

3. When the network connection is successful, the Command Prompt should receive replies from the dimensioner, as shown below. If not, contact your network administrator.

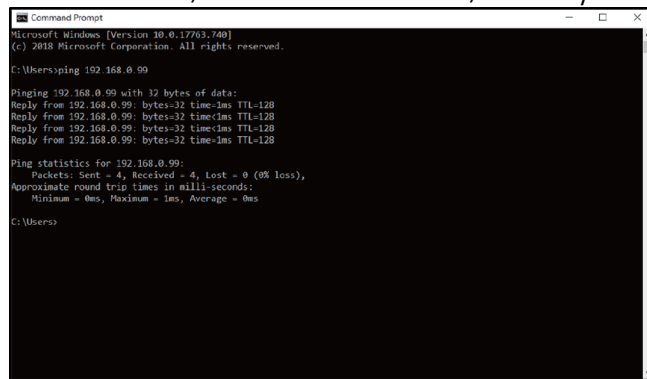

### 5.3.3.2. Web Browser Access

When the network connection is properly configured, the dimensioner can be accessed using a web browser from any device on the network. Enter the same IP address of your dimensioner and followed with the Web Server Port "8080".

**Note:** The colon ":" should be entered between the IP address and "8080".

METTLER TOLEDO		Communication	
Model:	TLD250	Bluetooth ID:	
Code:	TLD250-156U-1112-110-00	Mac:	00:50:08:0E:2E:AE
Device SN:		IP Address:	172.30.180.118
Camera SN:	020223022316	Subnet Mask:	255.255.252.0
<b>Software Version</b>		Gateway:	172.30.180.1
Linux System:	Ubuntu20.04	Web Server Port:	8080
Main Firmware:	2.00.162.119	Protocol Port:	65535
Interface Board:	1.01.005-75	<b>Service Support</b>	
CRC32:	0xB0C61458	TLD250.supportNA@mt.com	
		Please include call-back phone number	
www.mt.com/TLD250			
Mettler-Toledo GmbH, Im Langacher 44 CH-8606 Greifensee, Switzerland			

← ↻ 🏠 Not secure | 172.30.180.118:8080

## METTLER TOLEDO TLD250

- 🏠 Home / Info.
- 📏 Dimensioner
- ⚙️ Operation Mode
- 📐 Calibration
- 📺 Display
- 📡 Communication
- ⚙️ Maintenance

<b>L:</b>	0.0			
<b>W:</b>	0.0			
<b>H:</b>	0.0	in		
	0.000	kg		



METTLER TOLEDO		Communication	
Model:	TLD250	Bluetooth ID:	
Code:	TLD250-156U-1112-110-00	IP Address:	172.30.180.118
Device SN:		Subnet Mask:	255.255.252.0
Camera SN:	020223022316	Gateway:	172.30.180.1
<b>Software Version</b>		Web Server Port:	8080
Linux System:	Ubuntu20.04	Protocol Port:	65535
Main Firmware:	2.00.163.117		
Interface Board:	1.01.005-75		
CRC32:	0x73208D4B		

www.mt.com/TLD250  
Mettler-Toledo GmbH, Im Langacher 44 CH-8606 Greifensee, Switzerland



## 6. Service and Maintenance

### 6.1. Maintenance

Have an authorized METTLER TOLEDO service representative inspect and calibrate the device periodically. If the device is used for legal-for-trade purposes, consult the local weights and measures authorities for minimum inspection requirements. Contact your local authorized METTLER TOLEDO service representative for information about periodic inspection and calibration service. Safety inspections of the AC adapter and its connections must be performed periodically by a qualified electrician.

For repair services, Depot Repair is available in certain countries. If a problem occurs in the Camera module, the display module, or the electronics module, the module (or modules) can be shipped to the depot repair center for analysis, repair or replacement. Contact your local authorized METTLER TOLEDO service representative for information on Depot Repair.

### 6.2. Storage

If the device is not used for a long time, disconnect all connections, properly package the device and store it in an environment meeting the requirements:  $-10^{\circ}\text{C}$  -  $60^{\circ}\text{C}$ , at relative humidity of 5% to 95% non-condensing.

### 6.3. Disposal

In conformance with the European Directive 2012/19/EU on Waste Electrical and Electronic Equipment (WEEE) this device may not be disposed of in domestic waste. This also applies to countries outside the EU, per their specific requirements.





Please dispose of this product in accordance with local regulations at the collecting point specified for electrical and electronic equipment. If you have any questions, please contact the responsible authority or the distributor from which you purchased this device. Should this device be passed on to other parties, the content of this regulation must also be related.

### 6.4. Upgrading Firmware

Within the TLD250 electronics module, there are two electronic PCB's that can have their firmware updated.

1. The Main PCB Board Firmware. See section **5.1.4.5** and **6.4.3**
2. The Communication PCB firmware. See section **6.4.2**

	 <b>WARNING</b>
	<b>ONLY PERMIT QUALIFIED PERSONNEL TO PERFORM FIRMWARE UPDATES ON THE TERMINAL. PLEASE CONTACT A LOCAL METTLER TOLEDO REPRESENTATIVE FOR ASSISTANCE.</b>

#### 6.4.1. Recommended Backup Prior to Firmware Upgrade

Before loading a firmware upgrade into TLD250 dimensioner, it is highly recommended to run a

complete backup before executing the upgrade. Key parameter settings can be written down before the new firmware is installed. After the software update, the correct parameters can then be verified that they are populated in the TLD250.

## 6.4.2. Firmware Upgrade of Communication Board

To ensure a proper USB connection of TLD250 dimensioner and computer, please always use original METTLER TOLEDO accessor (P/N: 64057361, USB-A to USB-B cable) as follows:

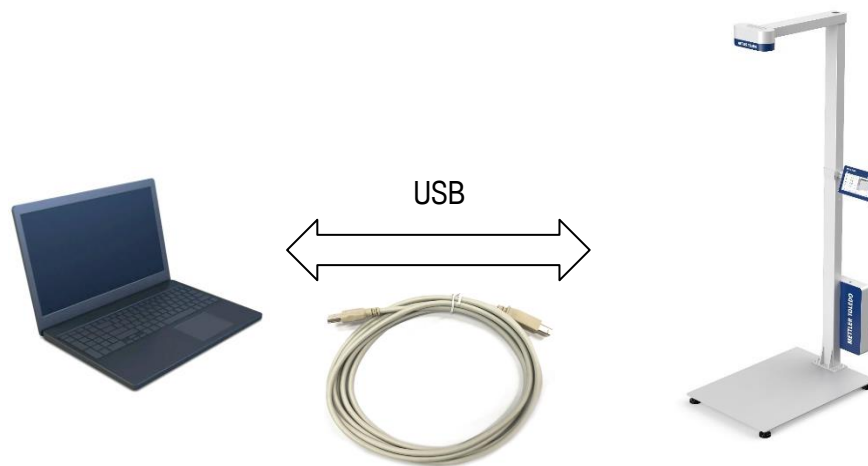

- Plug USB-A connector to the PC
  - Plug USB-B connector to the bottom of TLD250 Electronics module.
1. When upgrading the firmware, first power off the dimensioner via **Power > Shut Down**.

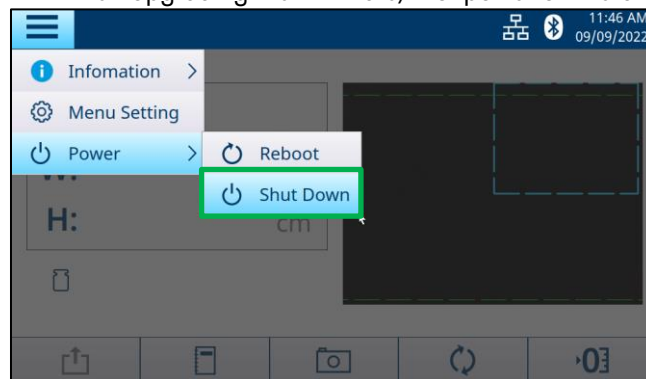

2. Open "File Explorer" on your computer

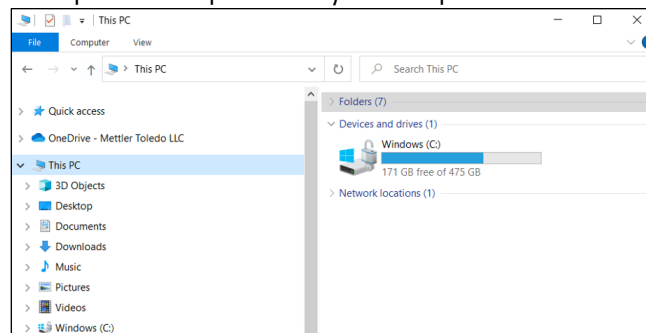

3. Press the calibration button with a thin pin or plastic stylus and hold for 10 seconds.



4. A new "BC Firmware" Drive (D:) can be found in the File Explorer.

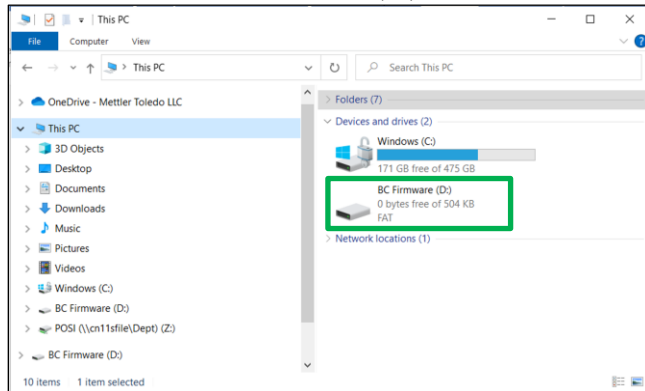

5. Then double click the "BC Firmware" Drive and delete "firmware.bin" file in it.

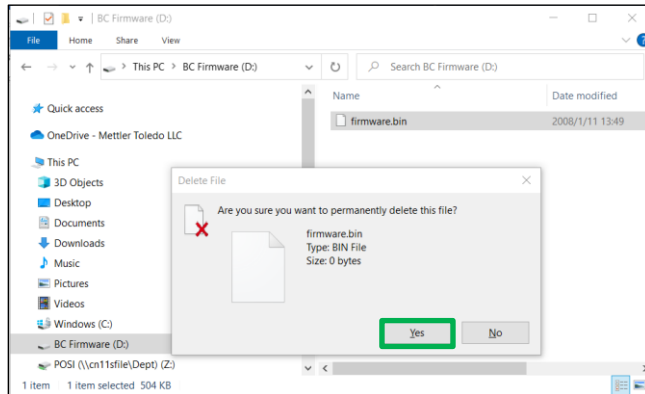

6. After deleting, please copy the new firmware file into the "BC Firmware" Drive. Unplug the USB cable and power on the dimensioner, the process of firmware upgrade is completed.

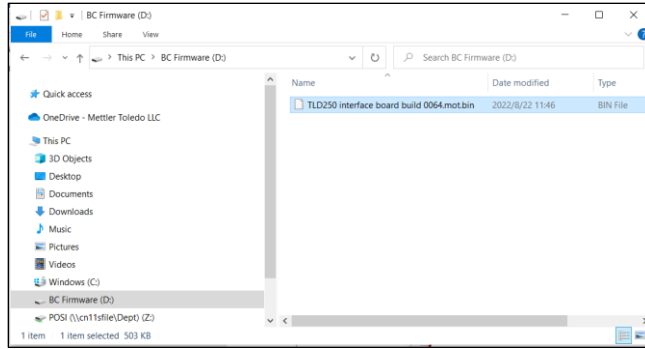

7. Access to **Information > Device**, to check the version status of firmware.

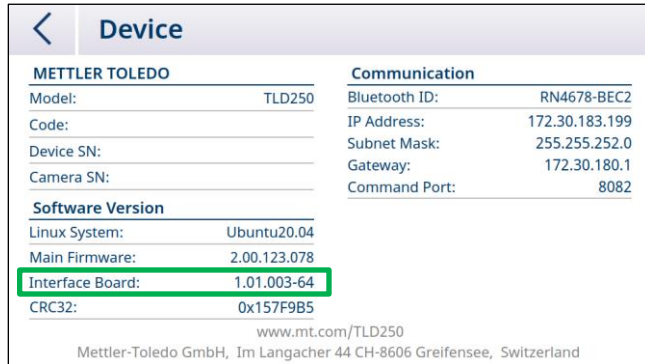

**Note:** If the communication board firmware upgrade keeps failing, please consider calling technical service for a new communication board.

### 6.4.3. Software Upgrade of Main Board

1. Please copy the upgrade file (TLD250xxxx.bin) to the root directory of the USB flash drive firstly.
2. Make sure no other software version is in the root file.
3. Insert the USB flash drive into the USB port of TLD250 electronics module.
4. Access to **Menu Setting > Maintenance > Firmware Upgrade**, then press .

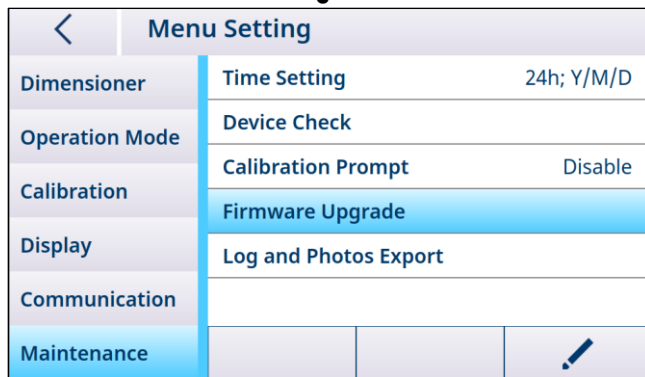

5. Press "Detect" to search the "TLD250xxxx.bin" software, then click "Upgrade".
6. A prompt will pop up after the upgrade is complete and click  for confirmation, then the system will restart automatically.

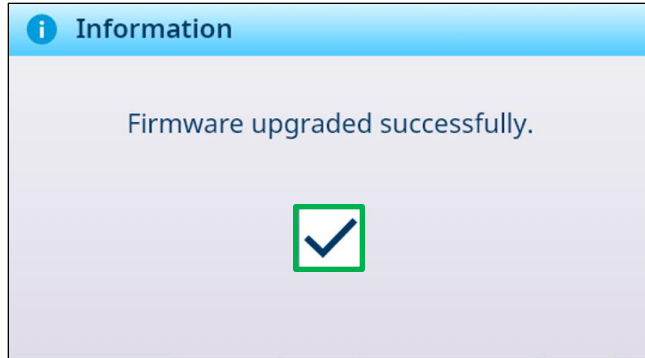



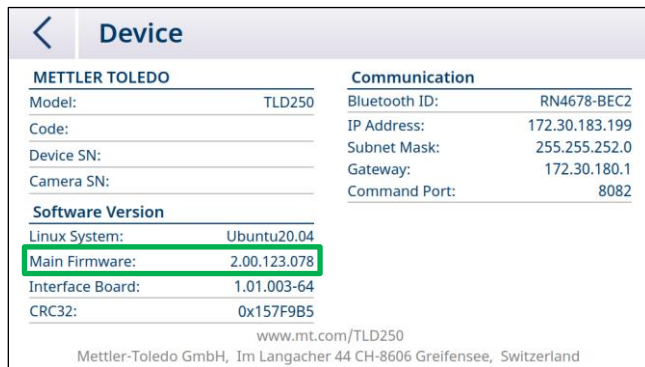

7. Access to **Information** > **Device** to check the version status of software.



**Note:** If the main board firmware upgrade keeps failing, please consider calling technical service for a new solid-state disk (SSD) memory card.

## 7. Advanced Troubleshooting

Issue	Possible reasons	Remedy
Zero Height Failed	Multiple bases of different height were detected in the Autosense Zone	Set the Autosense Zone within the desired base plate/platform Remove the obstacle from the desired base plate/platform
	No flat base was detected in the Autosense Zone	Level the base plate and/or base surface Put on the calibration box on the uneven scale
	Inappropriate measurement environment	Avoid measurement under too bright or dark areas, no glare from overhead lights or abundant shadows.
	Exceed the zero range	Adjust the zero range in the menu or lower the height of the new measuring platform above the base plate.
	The scale platter is too shiny or reflective	Replace with an appropriate scale platter
Display is Off	Power cable/adaptor is disconnected or damaged	Check the power cable connection along the electronic module, power adapter and AC outlet
		Check the display cable connection between the display and the electronic module
		Press the power button on the electronic module to power on the unit
No live image	Camera cable is disconnected or damaged	Check the camera cable connection with the electronic module
	Camera is damaged	Contact your local dealer or METTER TOLEDO Service
Incorrect dimensions	Measuring on different platform, but without zeroing the height	Zero the height and measure again. If the issue persists, calibration may be required.
No dimensions detected	The object is placed completely beyond the Autosense Zone	Place the objects at least partially within the Autosense Zone
	Over the maximum dimension	The object size is over the maximum dimension, please measure its dimensions manually, e.g., using a tape ruler
	Under the minimum dimension	The object size is under the minimum dimension, please measure its dimensions manually, e.g., using a tape ruler
	Under zero	Perform the Zero Height operation and measure again using a tape measure or ruler
	This symbol indicates the device failed to get stable dimensions,	
	The object is placed partially out of the measurement area	Place the object completely within the measurement area (green lines).
	The object edges are not well defined, e.g., rounded edges.	Reshape the object edges or repack the object
	The object is placed too close to the post of the device.	Place the object in the center of the measurement area with at least 5 cm from the flange of the lower post (Blue No Measure zone by post flange).
	Inappropriate object surface	Avoid the object surface that are reflective, shiny or too close to the base color.
	New camera sensor detected while the device is metrological locked	Calibrate the device
	Inappropriate measurement environment	Avoid measurement under too bright or dark lights, no glare from overhead lights or abundant shadows.

## 8. Spare Parts

Order number	Description
Extension Post	
30714982	Extension post, 40 cm, for TLD250-176
Camera Kit	
30714974	Camera Module Kit
Electronic Module Kit	
30714975	Electronic Module Kit
Scale Platter	
30499003	Platter Kit - BC30/60 SS Black
30714984	Platter Kit – BC150 SS Black (400x500mm)
Display Module	
30714976	0272 display module - Color Touch Display
30125729	0271 display module – Mono LCD Display Wall Mount
Display Bracket	
30714992	Display bracket
Calibration box	
30667982	Calibration box, 450x300x120mm, fit for TLD250-136 and TLD25-156
30668030	Calibration box, 450x300x300mm, fit for all TLD250 models
Power Supply and Cables	
30668034	Power supply, 60W, 12VDC
71210406	Power Cord Type-B 2.0m US CA MX JP
71210407	Power Cord Type-F 2.0m 180° EU
72243746	Power Cord Ext. Type-G UK
72243748	Power Cord Type-I 2.5m 180° CN AU
30714983	Power Cord Combination Kit Type-B Type-F Type-G and Type-I
64057361	Cable USB-A to USB-B, 3m, spare
30668031	0272 display module USB cable, 1.5m, spare
30668032	0272 display module HDMI cable, 1.5m, spare

## 9. Appendix

### 9.1. Technical Data

#### Measuring Capabilities

Model Type	TLD250-136	TLD250-156	TLD250-176
Accuracy_Cuboidal Object	0.5 cm (0.2 in)	0.5 cm (0.2 in)	1.0 cm (0.5 in)
Accuracy_Non-Cuboidal Object	1.0 cm (0.5 in)	1.0 cm (0.5 in)	2.0 cm (1.0 in)
Maximum object size (L x W x H)	100 x 60 x 40 cm (39 x 24 x 16 in)	100 x 60 x 60 cm (39 x 24 x 24 in)	100 x 60 x 80 cm (39 x 24 x 32 in)
Minimum object size (L x W x H)	6 x 6 x 6 cm (2.4 x 2.4 x 2.4 in)	6 x 6 x 6 cm (2.4 x 2.4 x 2.4 in)	12 x 12 x 12 cm (6 x 6 x 6 in)
Dimensions and weight			
Physical dimensions (LxWxH)	70 x 50 x 148.2 cm (27.6 x 19.7 x 58.3 in)	70 x 50 x 168.2 cm (27.6 x 19.7 x 66.2 in)	70 x 50 x 188.2 cm (27.6 x 19.7 x 74.1 in)
Net weight	Approx. 29.5 kg (65 lb)	Approx. 31 kg (68 lb)	Approx. 32.3 kg (71 lb)
Object requirements			
Object shape	Cuboidal and non-cuboidal objects (cylinder, donut, sphere, stacked or combined cuboidal objects)		
Object surface	All opaque packaging. Surfaces that are reflective, shiny and glossy chrome and/or black, covered with shrink/bubble wrap or polystyrene may cause performance deviations		
<b>Measurement Time</b>			
Time	1- 2 seconds		
<b>Display</b>			
Display / keypad	0271 - 2.8" MonoChrome graphic display 0272 - 7" color touchscreen display		
Languages	English, Chinese*, Portuguese*, Germany*, French*, Spanish* (*: Pending)		
<b>Power</b>			
Power supply	Universal 100-240 VAC, external power supply		
Input voltage / power consumption	12 VDC/ 5A / 60 W		
<b>Interface Connectivity</b>			
Connectors	Standard: 1 x RS232, 1 x USB, 1 x Ethernet RJ45 Optional: Bluetooth (Dual-Mode)		
Host protocols	CSN810, MT-SICS, Proto-U, USB Keyboard Wedge, USB HIDPOS		
<b>Operation Environment</b>			
Background lighting	Avoid direct sunlight and bright overhead lighting during measurement.		
Temperature / humidity	0° to 35°C (32° to 95°F) / Non-condensing		
<b>Approval</b>			
	NTEP, MC Cuboidals*, OIML, MID (*: Pending)		



<b>Others</b>	
Scale interface	USB (HIDPOS), TCP/IP (MT-SICS)
Barcode reader interface	USB
Secondary remote display (Optional)	O271-Monochrome graphic display or O272-7" color touchscreen display
Mechanical environment class	M1
Electromagnetic class	E1

## 9.2. Dimension Drawings

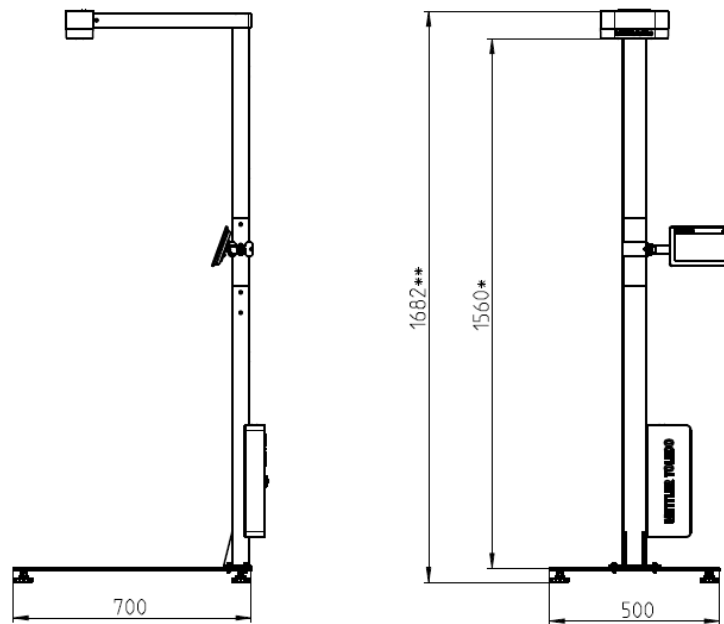

Type	*Camera height	**Physical height
TLD250-136	1360mm	1482mm
TLD250-156	1560mm	1682mm
TLD250-176	1760mm	1882mm



**To protect your product's future:**

METTLER TOLEDO Service assures the quality, measuring accuracy and preservation of value of this product for years to come.

Please request full details about our attractive terms of service.

[www.mt.com](http://www.mt.com)

For more information

**Mettler-Toledo (Changzhou) Measurement Technology Co., Ltd.**

111 Tai Hu Xi Road  
213125 Changzhou Jiangsu Province  
People's Republic of China  
[www.mt.com/contact](http://www.mt.com/contact)

Subject to technical changes.

© 11/2023 METTLE TOLEDO. All rights reserved.

30668023B

