

Guide for installers

METTLER TOLEDO MultiRange System solution analog Ex1

METTLER TOLEDO

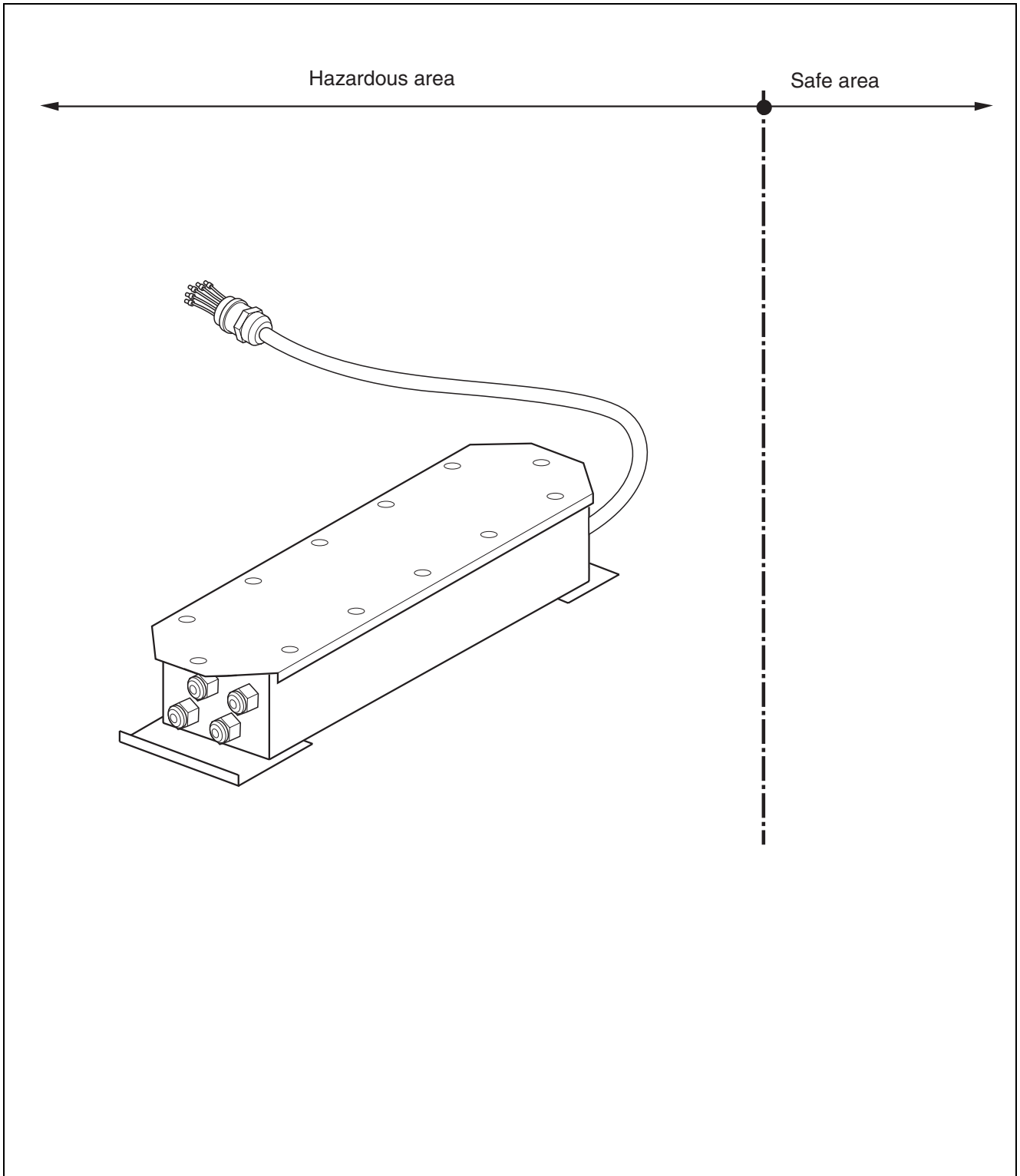

Contents		Page
1	Safety precautions	2
2	System overview	3
2.1	Using the System solution analog Ex1	3
2.2	Typical configurations	3
2.3	Description of components	3
3	Installation.....	4
3.1	Setting up System solution analog Ex1	4
3.2	Equipotential bonding	5
3.3	Connecting power supply	6
3.4	Configuration	6
3.5	Corner adjustment	6
4	Replacing connection cables	8
4.1	Making connection cables	8
4.2	Installing new connection cable.....	9
5	Technical data	10
5.1	General technical data.....	10
5.2	Intrinsically safe characteristic values.....	11
5.3	Dimensional drawing	11
6	Accessories.....	12

1 Safety precautions



The System solution analog Ex1 is approved for operation in Zone 1 and 21 hazardous areas.

Particular care is required when using weighing systems with the System solution analog Ex1 in hazardous areas. The code of practice is oriented to the "Safe Distribution" concept drawn up by METTLER TOLEDO.

- Competence** ▲ The System solution analog Ex1 may only be installed, maintained and repaired by authorised METTLER TOLEDO service personnel.
- Ex approval** ▲ No modifications may be made to the device and no repair work may be performed on the modules. Any weighing cells or system modules that are used must comply with the specifications contained in the installation instructions. Non-compliant equipment jeopardises the intrinsic safety of the system, cancels the "Ex" approval and renders any warranty or product liability claims null and void.
- ▲ The safety of the weighing system is only guaranteed when the weighing system is operated, installed and maintained in accordance with the respective instructions.
- ▲ Also comply with the following:
- the instructions for the system modules and weighing cells,
 - the regulations and standards in the respective country,
 - the statutory requirement for electrical equipment installed in hazardous areas in the respective country,
 - all instructions related to safety issued by the owner.
- ▲ The explosion-protected weighing system must be checked to ensure compliance with the requirements for safety before being put into service for the first time, following any service work and every 3 years, at least.
- Operation** ▲ Prevent the build-up of static electricity. Always wear suitable working clothes when operating or performing service work in an hazardous area.
- ▲ Do not use protective coverings for the devices.
- ▲ Avoid damage to the system components.
- Installation** ▲ Only install or perform maintenance work on the weighing system in the hazardous areas if the following conditions are fulfilled:
- the intrinsically safe characteristic values and zone approval of the individual components are in accord with one another,
 - the owner has issued a permit ("spark permit" or "fire permit"),
 - the area has been rendered safe and the owner's safety co-ordinator has confirmed that there is no danger,
 - the necessary tools and any required protective clothing are provided (danger of the build-up of static electricity).
- ▲ The certification papers (certificates, manufacturer's declarations) must be present.
- ▲ Lay cabling securely so that it does not move and effectively protect it against damage.
- ▲ Only route cables into the housing of the system modules via the suitable cable gland and ensure proper seating of the seals.

2 System overview

2.1 Using the System solution analog Ex1

The System solution analog Ex1 is used to connect intrinsically safe analog weighing cells to a weighing terminal with an integrated A/D converter.

Here, the System solution analog Ex1 adds up the analog voltage signals of the individual weighing cells.

With the System solution analog Ex1, it is possible to construct special scales, e.g. container scales consisting of several DMS weighing cells with a container placed on top.

2.2 Typical configurations

2.2.1 System solution analog Ex1, intrinsically safe weighing terminal and DMS weighing cells

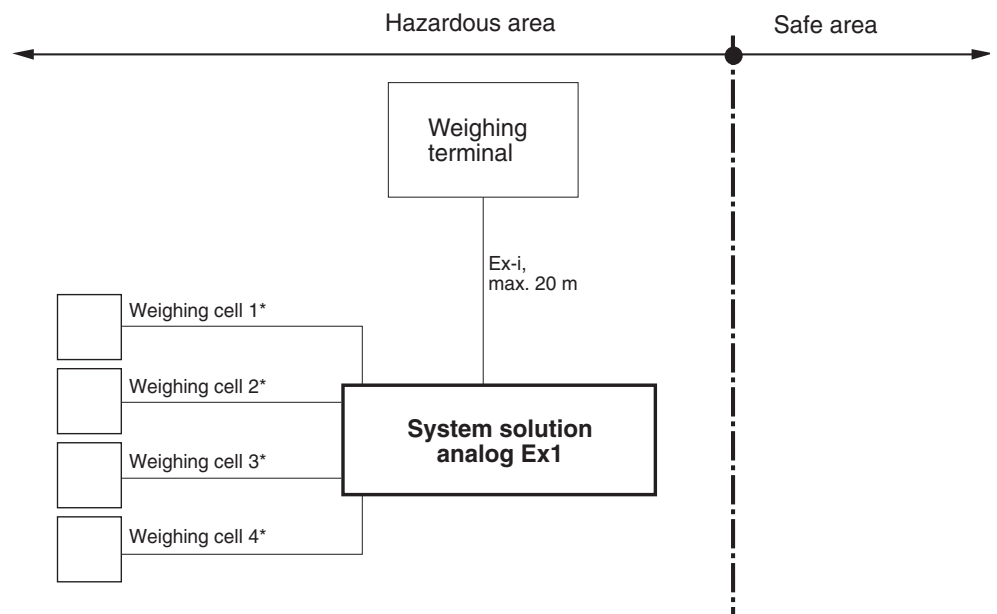

- * Weighing cells must be approved for the hazardous area.
The intrinsically safe characteristic values must be in accord with those of the A/D converter of the weighing terminal.

2.3 Description of components

System solution analog Ex1	Ignition protection type	EN	II 2G	EEx ia IIC T4
			II 2D	IP68 T75°C
	Temperature range	-20 °C to +60 °C		
	Protection type	IP68		
	Connection cable	5 m		

3 Installation

3.1 Setting up System solution analog Ex1

3.1.1 Preparing System solution analog Ex1

1. Open cover of the System solution analog Ex1 by loosening the 12 screws.
2. Remove blind plugs for connection of the weighing cell cables.

3.1.2 Connecting DMS weighing cells

CAUTION

→ Weighing cell cables may not be shortened!

Preparing cell cable

1. Strip cable end approx. 180 mm.
2. Shorten cable shielding to 6 mm.
3. Strip the wire ends approx. 6 mm and twist them.
4. Push on the wire end ferrules and press them on firmly with a pair of crimping pliers.

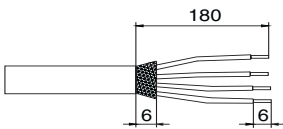

Attaching cable gland to cell cable

Note

Measures for shielding against incoming and outgoing interference are especially important with longer cell cables. The maximum interference immunity classes will only be achieved with careful and proper installation and wiring of all connected peripherals and weighing platforms.

For this purpose, it is extremely important to connect the shielding on both sides in a professional manner.

The CE-conformity of the entire system is the responsibility of the person commissioning the device.

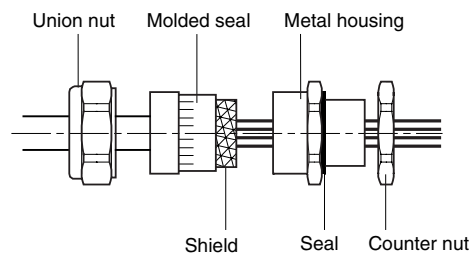

1. Slide the union nut and moulded seal over the prepared cable.
2. Place cable shielding over the contact.
3. Screw in metal housing with union nut.

Connecting cell cables to System solution analog Ex1

1. Screw cable to the housing. Ensure proper seating of seal when doing so!
2. Identify weighing cells (1 to 4).
3. Connect weighing cell cables in accordance with the drawing to the System solution analog Ex1.
For 6-lead weighing cells with a Sense connection, lead the Sense connections from each of two weighing cells to one terminal and open the two hook switches (1) if necessary.
4. Close the cover of the System solution analog Ex1 again. Ensure correct position of cover seal when doing so.

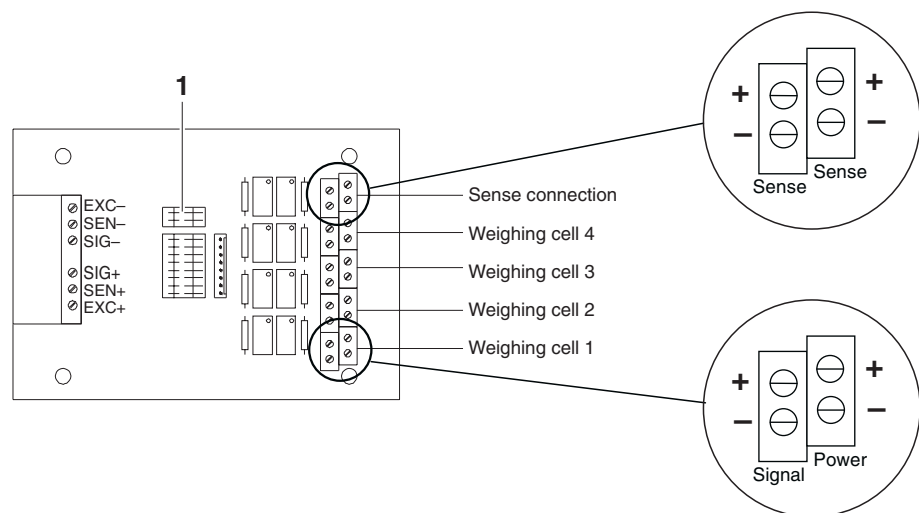

Connecting System solution analog Ex1 to weighing terminal

1. Lay connection cable to weighing terminal and pull it into the housing.
2. Screw cable to the housing. Ensure proper seating of seal when doing so.
3. Connect wires. See terminal diagram of the intrinsically safe weighing terminal.

3.2 Equipotential bonding

Equipotential bonding must be installed by an electrician authorised by the owner. METTLER TOLEDO Service only has a monitoring and consulting function here.

- Connect equipotential bonding (PA) of all devices (power supply unit, weighing terminal and weighing platform) in accordance with the terminal diagram and the country-specific regulations and standards. In the process it must be ensured that
- all device housings are connected to the same potential via the PA terminals,
 - no circulating current flows via the cable shielding for intrinsically safe circuits,
 - the neutral point for equipotential bonding is as close to the scale as possible.

3.3 Connecting power supply

See guide for installers of the intrinsically safe weighing terminal or power supply.

3.4 Configuration

Configuration of the weighing system occurs via service mode of the A/D converter of the connected weighing terminal. See operating instructions of the weighing terminal.

3.5 Corner adjustment

Corner compensation must be performed after configuration and calibration of the weighing system.

3.5.1 Checking cornerload

Checking of a multi-sensor weighing platform with four weighing cells is described in the following.

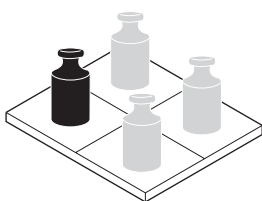

1. Place the test weight (1/3 of maximum load) in the centre of the load plate and tare.
2. Load test weights in succession in the middle of each of the four quadrants, and note absolute value with sign.

Adjustment is required for deviations greater than the permissible verification error limit.

3.5.2 Adjusting corners

Notes

- Begin the adjustment at the corner with the greatest deviation.
- The adjustment of weighing cell 1 occurs at the potentiometer pair 1, cell 2 at pair 2, etc.

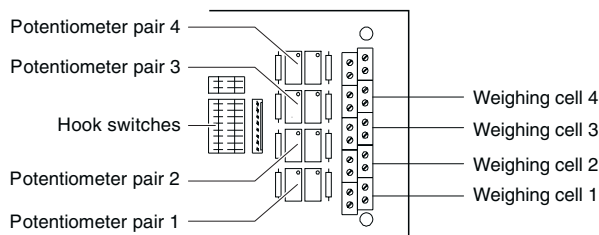

1. Switch off weighing system.
2. Open all hook switches.
3. Move all potentiometers to the middle position.
4. With a **positive** deviation: Turn both potentiometers the same number of rotations to the **right**.
With a **negative** deviation: Turn both potentiometers the same number of rotations to the **left**.
5. After completing corner adjustment, screw the cover of the system solution back on. Ensure proper seating of seal when doing so.

Notes

The following work must be performed after a weighing cell has been replaced:

- Recalibrate weighing system with maximum load.
- Check cornerload and adjust if need be.

4 Replacing connection cables

4.1 Making connection cables



EXPLOSION HAZARD

- Take the parameters of the cable used into consideration when checking the intrinsically safe parameters.
- Use only cables approved for use in the hazardous area.

Customer-specific weighing platform cables for intrinsically safe circuits must be fabricated as follows:

	Cable	Dimension A (system solution)	Dimension B (terminal)	Max. length
System solution analog Ex1 – weighing terminal	3 x 2 x 0.75 mm ²	80 mm	215 mm	100 m

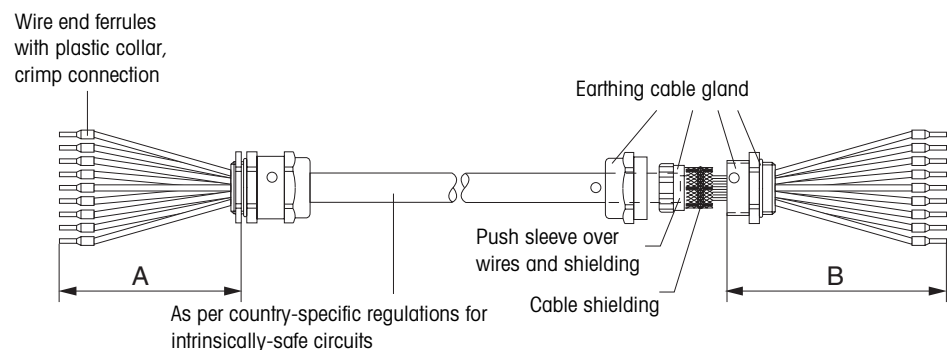

1. Cut cable to length and strip cable ends according to dimension A/B.
2. Shorten shielding on both sides to 10 mm.
3. Strip wire ends.
4. Crimp wire end ferrules onto wire ends with a crimping tool.
5. Push second rear section of earthing cable gland onto cable. Do not damage the insulation of the wires here.
6. Push sleeve over wires and shield. Fold over cable shielding.
7. Push on front section of cable gland and screw onto rear section.

4.2 Installing new connection cable

1. Open System solution analog Ex1 and detach preinstalled connection cable from the junction PCB.
2. Disconnect earthing cable gland and pull out cable.
3. Pull newly made connection cable into the terminal box and secure with the earthing cable gland. Ensure correct position of seal when doing so.
4. Attach wires according to labelling at the junction PCB.
5. Close housing cover of the System solution analog Ex1. Ensure correct position of seal when doing so.
6. Lay connection cable securely to weighing terminal and connect according to the guide for installers.

5 Technical data

5.1 General technical data

Explosion protection	
Ignition protection type EN	Metric terminal box II 2 G EEx ia IIC T4 II 2 D IP68 T75°C
Temperature range	-20 °C to +60 °C
Preinstalled cable	5 m
Number of weighing cells	max. four (connect only one weighing cell per connection terminal!)
Permissible platform resistance	$\geq 87.5 \Omega$
Housing	
Housing protection type	IP68
Housing type	Chrome-nickel-steel (1.4301)

5.2 Intrinsically safe characteristic values

Power supply and measurement circuit

	$U_{i \max}$	$I_{i \max}$	$P_{i \max}$
KL5, KL6, KL7	20 V	350 mA	1.2 W

CAUTION

The following conditions must be fulfilled before you connect the System solution analog Ex1 to the A/D converter of the weighing terminal:

- $U_{i, \text{cell}} > U_{0, \text{A/D converter}}$
 $I_{i, \text{cell}} > I_{0, \text{A/D converter}}$
 $P_{i, \text{cell}} > P_{0, \text{A/D converter}}$
 $n \times C_{i, \text{cell}} + C_{\text{cable}} < C_{0, \text{A/D converter}}$ (n = number of connected cells)
 $L_{i, \text{cell}} + L_{\text{cable}} < L_{0, \text{A/D converter}}$
- $U_{i \max, \text{system solution}} > U_{0, \text{A/D converter}}$
 $I_{i \max, \text{system solution}} > I_{0, \text{A/D converter}}$
 $P_{i \max, \text{system solution}} > P_{0, \text{A/D converter}}$

The weighing cell cable and connection cable of the System solution analog Ex1 must be taken into account here when calculating the inductivities and capacitances.

5.3 Dimensional drawing

Metric terminal box

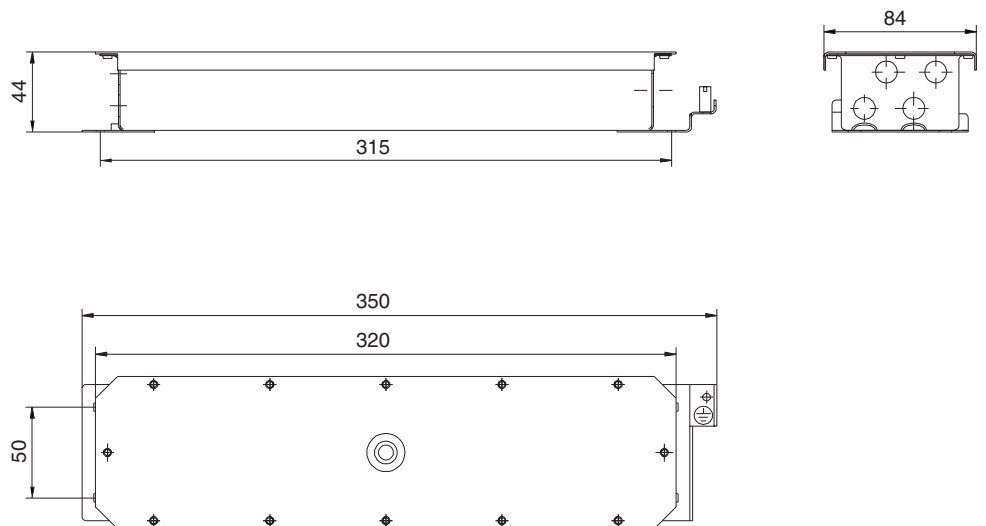

Dim. in mm

6 Accessories

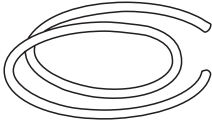
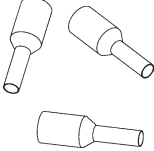
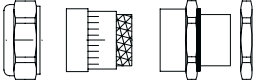
Graphic	Designation	Order No.
	Cable For intrinsically safe circuits, Ex-i 3 x 2 x 0.75 mm ² , shielded, 100 m	00 504 638
	Wire end ferrules H 0.75 / 13, with plastic collar, 100 pcs.	00 504 639
	Cable gland M16 x 1.5 EEx e II, 6 pcs.	22 006 708



22012215

Subject to technical changes © Mettler-Toledo (Albstadt) GmbH 04/09 Printed in Germany 22012215

Mettler-Toledo (Albstadt) GmbH

D-72458 Albstadt

Tel. ++49-7431-14 0, Fax ++49-7431-14 232

Internet: <http://www.mt.com>