

**Pit construction diagram  
00705813H**



METTLER TOLEDO MultiRange  
DRY pit / WET pit (part 1)  
**DN - line**

Subject to technical changes © Mettler-Toledo (Albstadt) GmbH Printed in Germany 01/03 english

**Standard equipment**

- 2 Pit angle, lengthwise
- 2 Pit angle, crosswise
- 4 Hex bolts M12x30 DIN 933
- 4 Nuts M12 DIN 934
- 1 Pit construction diagram

**1. Determine location of weighing platform**

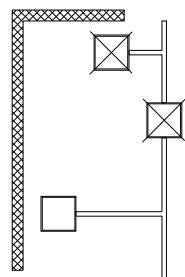

- Load-bearing capacity of pit base:  
min. 1300kg/25cm<sup>2</sup>

**2. Determine location of terminal**

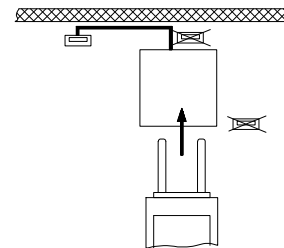

- Set up terminal to ensure good access.
- Length of connection cable terminal 5m.

**3. Prepare framework pit**

The following points are to consider

- Position of drain, look at the dimension drawings.
- Cable conduit diameter min. 4 cm.
- Do not use right-angled pipe, but two pipes of 45 °.

Excavate framework pit as specified in the table below (proposal)

weighing platform	length	x	width
DND... (125x100)	185	x	160
DNE... (150x125)	210	x	185
DNES...(150x150)	210	x	210
DNF... (free size)	length of weig. platform +60	x	width of weig. platform +60

Dry pit

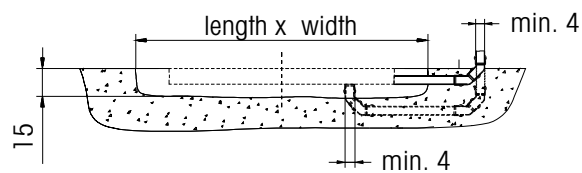

Wet pit

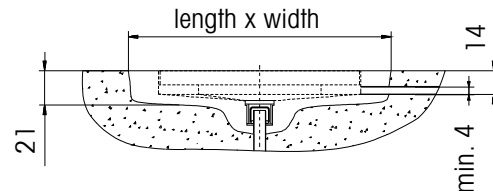

**4. Concrete forming**

- a) Prepare stable wooden frame. Check that the frame is rectangular. Check diagonal. Dimensions see table.
- b) Assemble steel pit frame, and fasten to wooden frame with nails.
- c) Install wooden frame together with pit frame in the framework pit. The pit frame must be leveled exactly.

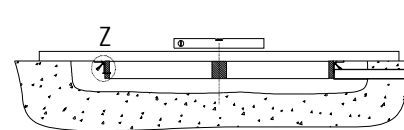
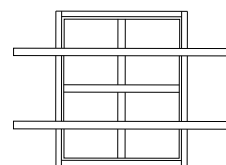
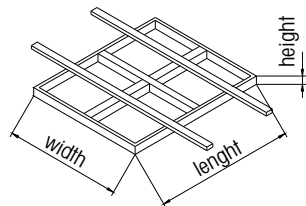

Detail Z

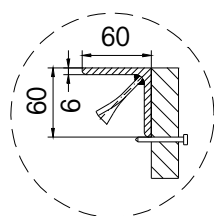

weighing platform	length	x	width	x	height
DND... (125x100)	127	x	102	x	8.8
DNE... (150x125)	152	x	127	x	8.8
DNES...(150x150)	152	x	152	x	8.8
DNF... (free size)	length of weig. platform +2	x	width of weig. platform +2	x	8.8

**5. Dimension drawings**

**5.1 Dry pit**

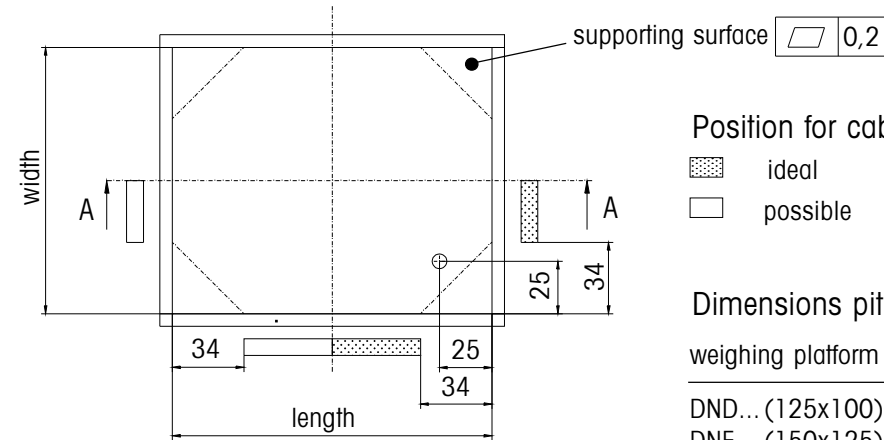
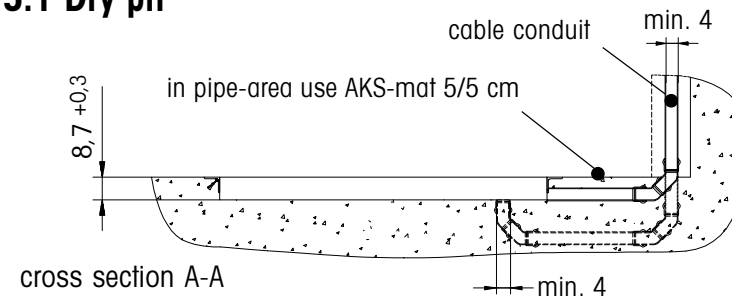

Position for cable conduit  
 ideal  
 possible

Dimensions pit frame

weighing platform	length	x	width
DND... (125x100)	127	x	102
DNE... (150x125)	152	x	127
DNES...(150x150)	152	x	152
DNF... (free size)	length of weig. platform +2	x	width of weig. platform +2

**5.2 Wet pit**

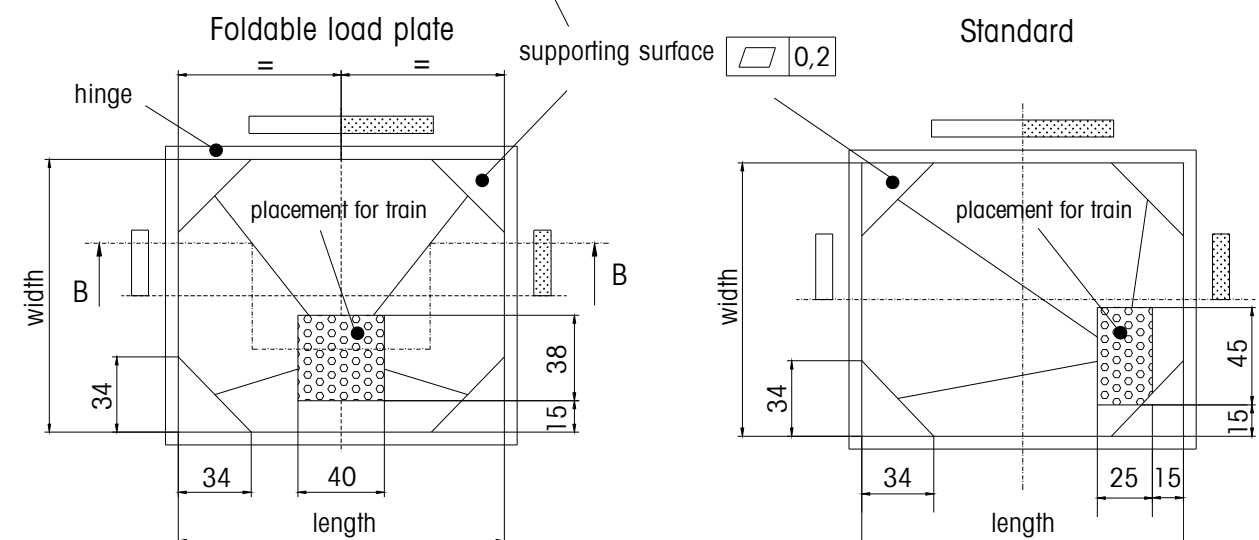
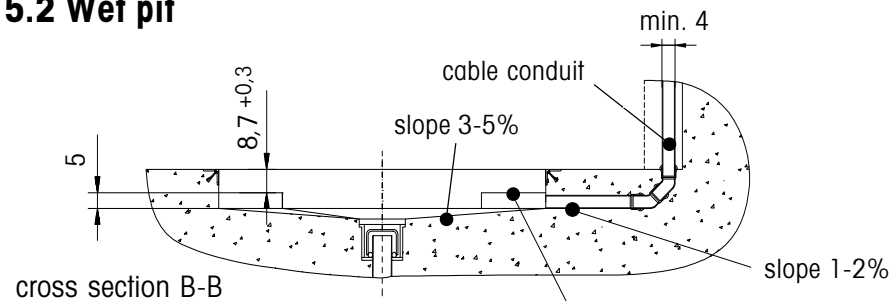

**Pit construction diagram  
00705813H**

**METTLER TOLEDO**

METTLER TOLEDO MultiRange  
DRY pit (part 1)  
**N-line / Spider**

Subject to technical changes © Mettler-Toledo (Albstadt) GmbH Printed in Germany 01/03 english

**Standard equipment**

- 2 Pit angle, lengthwise
- 2 Pit angle, crosswise
- 4 Hex bolts M12x30 DIN 933
- 4 Nuts M12 DIN 934
- 1 Pit construction diagram

**5. Dimension drawings**

**Pit construction diagram 00705813H**

Dry pit (part 2)  
**N-Linie / Spider**

**5.1 Dry pit**

**Dimensions in cm**

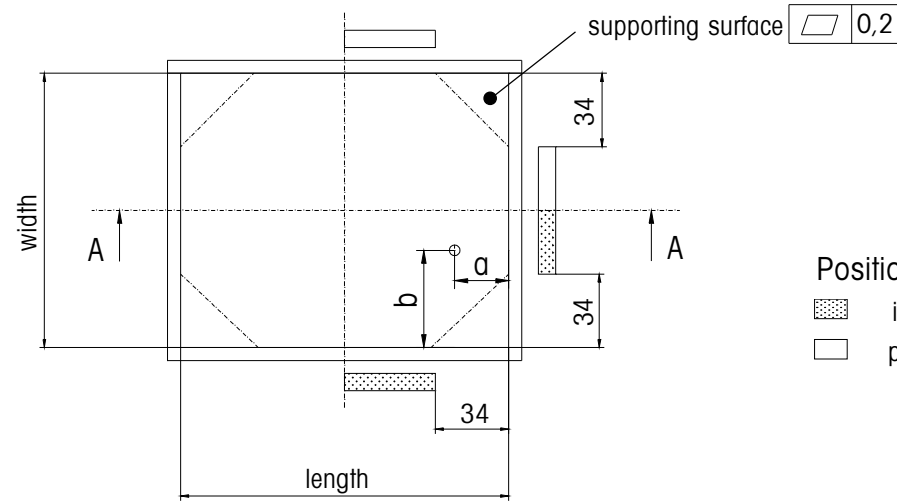
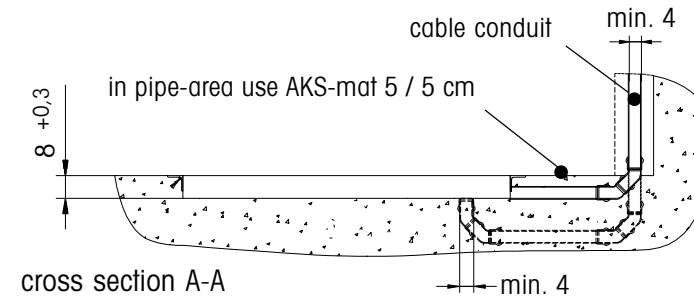

**Dimension pit frame**

weighing platform	length	x	width
NDS... / Spider (100x100)	102	x	102
ND... / Spider (125x100)	127	x	102
NE... / Spider (150x125)	152	x	127
NES... / Spider (150x150)	152	x	152
NF... / Spider F (free size)	length of weig. platform +2	x	width of weig. platform +2

**Position for cable conduit**

weighing platform	a	x	b
NDS... / Spider (100x100)	19,5	x	32,5
ND... / Spider (125x100)	19,5	x	32,5
NE... / Spider (150x125)	19,5	x	45
NES... / Spider (150x150)	19,5	x	57,5
NF... / Spider F (free size)	19,5	x	width of weig. platform -17,5

**1. Determine location of weighing platform**

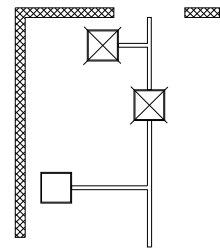

- Load-bearing capacity of pit base:  
min. 1300kg/25cm<sup>2</sup>

**2. Determine location of terminal**

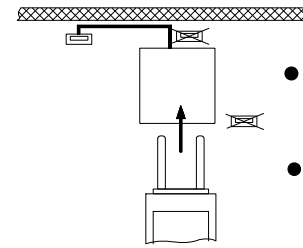

- Set up terminal to ensure good access
- length of connection cable terminal 5m

**3. Prepare framework pit**

The following points are to consider

- Position of drain, look at the dimension drawings
- Cable conduit diameter min. 4 cm
- Do not use right-angled pipe, but two pipes of 45 °

Excavate framework pit as specified in the table below (proposal)

weighing platform	length	x	width
NDS... / Spider (100x100)	160	x	160
ND... / Spider (125x100)	185	x	160
NE... / Spider (150x125)	210	x	185
NES... / Spider (150x150)	210	x	210
NF... / Spider F (free size)	length of weig. platform +60	x	width of weig. platform +60

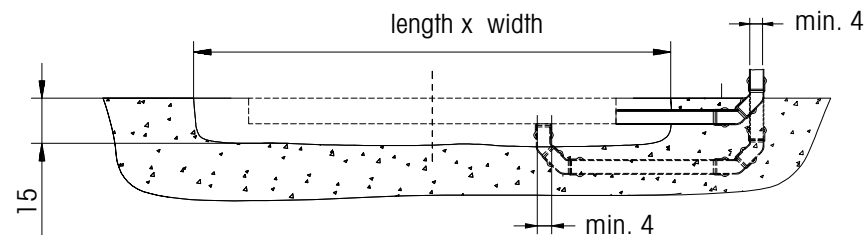

**4. Concrete forming**

- a) Prepare stable wooden frame. Check that the frame is rectangular. Check diagonal. (dimensions see table).
- b) Assemble steel pit frame, and fasten to wooden frame with nails.
- c) Install wooden frame together with pit frame in the framework pit. The pit frame must be leveled exactly.

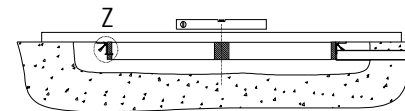
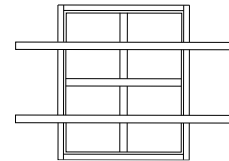
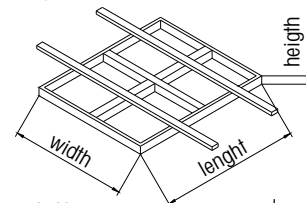

Detail Z

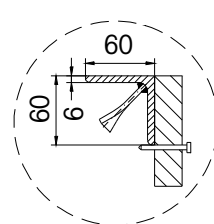

weighing platform	length	x	width	x	height
NDS... / Spider (100x100)	102	x	102	x	8
ND... / Spider (125x100)	127	x	102	x	8
NE... / Spider (150x125)	152	x	127	x	8
NES... / Spider (150x150)	152	x	152	x	8
NF... / Spider F (free size)	length of weig. platform +2	x	width of weig. platform +2	x	8