

Replacement Instructions for 40 micron Filter (58091502)

The 40 micron Filter kit can be ordered from Mettler-Toledo Thornton (part number 58091502). The Kit contains two replacement filters for a 5000TOC Sensor. One filter is located at the inlet to the pressure regulator (External Filter) and the other is located at the top of Conductivity Sensor 2 (Internal Filter).

EXTERNAL FILTER REPLACEMENT

Note: During the following steps use caution so as not to loosen the “Sample Inlet” bulkhead fitting in the side wall of the sensor case.

NOTE: During filter replacement, water may drain from the tubing and fittings. Use a sponge or absorbent towel to dry components prior to re-assembly.

1. Power down the 5000TOC Sensor per the instruction manual (P/N 84445), turn off the feed water supply and isolate sample inlet tube from sample point connection.

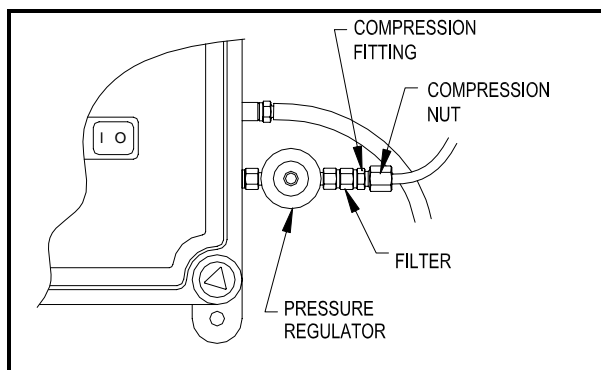

Figure 1. Inlet 40 micron Filter and Pressure Regulator

2. Sequentially remove the compression nut with the inlet water tube, compression fitting, and filter from the inlet side of the pressure regulator.
3. Screw on the new filter (P/N 58091502) and tighten it finger tight plus one half turn with a wrench.
4. In the same manner replace the fitting and nut with the inlet tube.
5. Turn the feed water supply on and check for leaks. Tighten any leaking connections then restore power to the sensor.
6. Restart the TOC process per the instruction manual (P/N 84445).

INTERNAL FILTER REPLACEMENT

1. Completely power down the 5000TOC Sensor per the instruction manual (P/N 84445), including the external AC power, and turn off the feed water supply.
2. Open the sensor cover with the special tool provided in the Customer Installation Kit that came with the sensor.
3. The location of Conductivity Sensor 2 is shown in Figure 2. The filter is located on the top of the conductivity sensor and is between the street tee fitting and the barb fitting connected to the tubing. See Figure 3.
4. Unscrew the street tee fitting from the top of the sensor then unscrew the filter fitting.
5. Screw the new filter (P/N 58091502) onto the barb fitting. Re-attach the street tee fitting and tighten both connections finger tight plus one half turn with a wrench.
6. **Caution: Do not allow any kinks in the tubing.** Replace the street tee fitting on the sensor and tighten it finger tight plus one half turn with a wrench.

7. Turn the feed water supply on and check for leaks. Tighten any leaking connections then restore power to the sensor.
8. Close and secure the cover using the special tool provided and restore power to the 5000TOC Sensor.
9. Restart the TOC process per the instruction manual (P/N 84445).

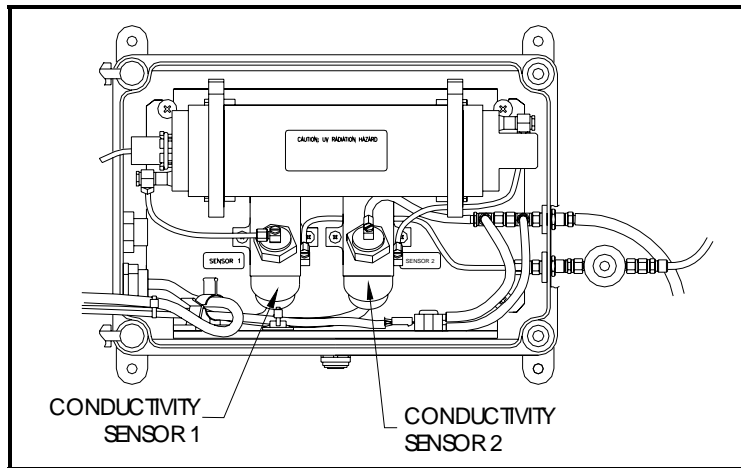

Figure 2. Location of Conductivity Sensor #1 and #2

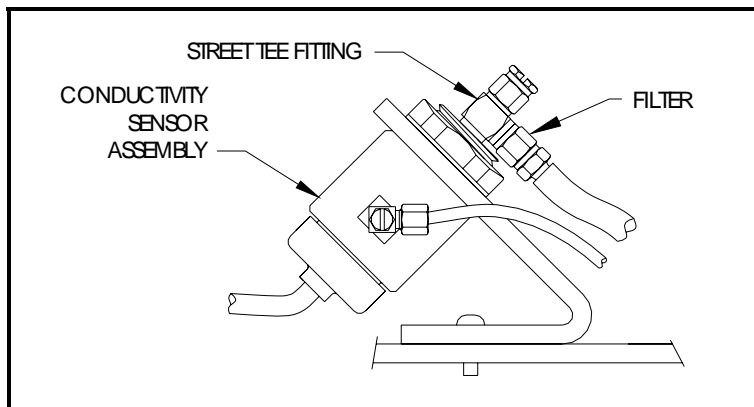

Figure 3. Location of Filter and Street Tee Fitting at Conductivity Sensor #2