

InTrac® 798-M
InTrac® 798-P

Instruction manual

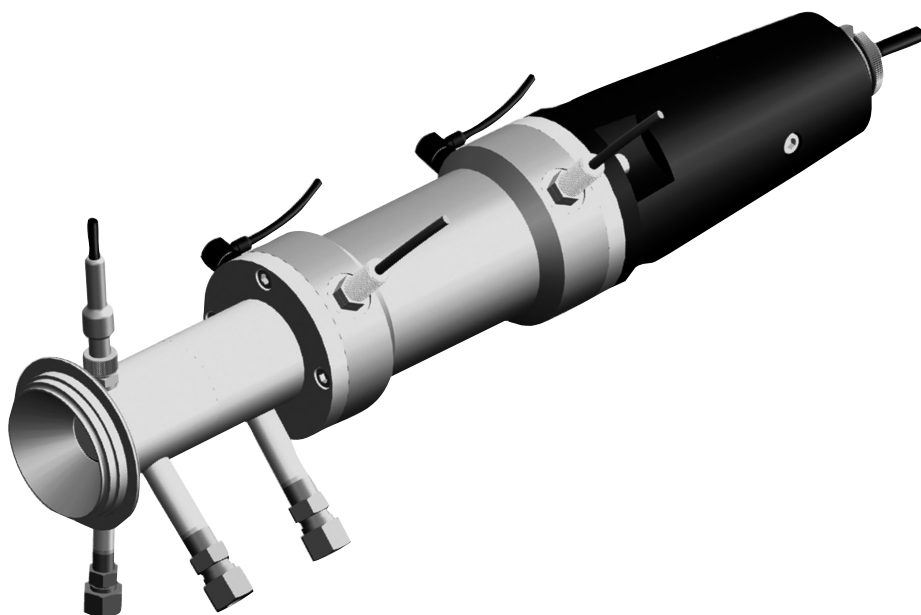

InTrac® 798-M

InTrac® 798-P

Instruction manual

How to use this instruction manual

This instruction manual is an integral part of the Mettler Toledo retractable housings InTrac 798-M and InTrac 798-P and contains notes and instructions that are important for safety and operation.

All persons working on or with the InTrac 798-M and/or InTrac 798-P must have first read and understood the sections appropriate to the work in hand.

Please read this instruction manual carefully before using the InTrac housing. Keep this document close to the unit, so that operating personnel may easily be able to refer to it at any time.



First read Chapter 2 «Safety»!

© It is forbidden to reprint this instruction manual in whole or part.
No part of this manual may be reproduced in any form, or modified, copied or distributed using electronic systems, in particular in the form of photocopies, photographs, magnetic or other recordings, without written consent of Mettler-Toledo GmbH, Process Analytics, CH-8902 Urdorf, Switzerland.

All rights reserved, in particular reproduction, translation and patenting/registration.

InTrac® is a registered trade mark of Mettler-Toledo GmbH, CH-8606 Greifensee, Switzerland

Contents

| | | |
|----------|--|-----------|
| 1 | Introduction | 31 |
| 2 | Safety | 31 |
| 2.1 | Introduction | 31 |
| 2.2 | Intended use | 31 |
| 2.3 | Inappropriate use | 31 |
| 2.4 | Basic principles | 32 |
| 2.5 | Warning notices and symbols | 32 |
| 2.6 | Responsibility, organizational measures | 32 |
| 2.7 | Product-specific hazards | 33 |
| 2.8 | Residual hazards | 33 |
| 2.9 | Emergency measures | 34 |
| 2.10 | Safety measures | 34 |
| 2.11 | Modifications | 34 |
| 3 | Product descriptions | 35 |
| 3.1 | Uses and features | 35 |
| 3.2 | Function of the flushing chamber | 35 |
| 3.3 | Function of the manual retractable housing (InTrac 798-M) | 36 |
| 3.4 | Function of the pneumatic retractable housing (InTrac 798-P) | 36 |
| 4 | Installation and start-up | 37 |
| 4.1 | Mounting position of the retractable housing | 37 |
| 4.2 | Calibration of the pH-electrode or the transmitter | 37 |
| 4.3 | Fitting of the electrode into the retractable housing | 38 |
| 4.4 | Removing the electrode from the retractable housing | 38 |
| 4.5 | Mounting the retractable housing | 39 |
| 4.6 | Removing the retractable housing | 39 |
| 4.7 | Connecting the sterilization or flushing lines | 39 |
| 5 | Operation | 40 |
| 5.1 | Sterilization of the electrode | 40 |
| 5.1.1 | General | 40 |
| 5.1.2 | Sterilization of the electrode in the reactor | 40 |
| 5.1.3 | Sterilization of the electrode in the flushing chamber | 40 |
| 5.2 | Removing the electrode without interrupting the process | 40 |
| 5.3 | Fitting the electrode without interrupting the process | 40 |
| 6 | Maintenance | 41 |
| 6.1 | Calibration intervals of pH electrodes | 41 |
| 6.2 | Cleaning the electrode | 41 |
| 6.3 | Storing the electrode | 41 |
| 6.4 | Changing the O-rings | 41 |
| 7 | Product specifications | 42 |
| 7.1 | Technical data | 42 |
| 7.2 | Spare parts / ordering information | 43 |
| 7.3 | Installation of the safety system InTrac 798 | 44 |
| 7.4 | Installation of the sealing set InTrac 798 | 45 |
| 7.5 | Fitting of 3/2-way check-back indicator | 46 |
| 7.6 | Fitting of non-Ex inductive back-check position indicator | 47 |
| 8 | Decommissioning, storage, disposal | 48 |
| 8.1 | Decommissioning | 48 |
| 8.2 | Storage | 48 |
| 8.3 | Disposal | 48 |

1 Introduction

- The retractable housing InTrac798 is safe to operate. When used correctly, it represents no danger.
- Before starting to use the housing, carefully read this instruction manual and the safety precautions and warnings contained in it must be observed.
- The retractable housing has been tested by METTLER TOLEDO and dispatched ready for installation.

In addition to this instruction manual please also note the following:

- all local safety regulations concerning the execution of pneumatic and water installations.
- all instructions and warning remarks in the publications of the products that are used in conjunction with the retractable housing (electrodes, sensors, controls, etc.).
- all safety precautions for the plant into which the retractable housing will be installed.
- all instructions and warnings labeled on the retractable housing.

2 Safety

2.1 Introduction

The instruction manual contains the most important information for using InTrac798 efficiently and according to regulations. A basic condition for secure handling and operation without malfunctions is a knowledge of these safety instructions and observance of the further warnings in the instruction manual.

The operator as well as all persons working with InTrac798 must follow this instruction manual, especially the safety instructions. In addition, regulations in force at the point of use of the housing as well as legal regulations must be complied with.

The instruction manual must be stored where it is constantly accessible and available to any person working with the InTrac798.

2.2 Intended use

InTrac798 is a retractable housing for the installation of 120 mm long electrodes with a 12 mm shaft diameter. It makes possible the withdrawal of the electrodes for servicing purposes during an ongoing process or during cleaning phases with CIP solutions, in order to be able to protect the electrodes from negative influences. After servicing, the electrode can be sterilized in the flushing chamber and then re-inserted into the process without influencing the sterile content of the process vessel itself.

The following are also part of operation in accordance with the regulations:

- adherence to the instructions, regulations and information in this instruction manual.
- correct maintenance of the housing.
- operation in compliance with regulations concerning the environment, operating conditions, and the permissible mounting positions.
- adherence to local legislation.

2.3 Inappropriate use

Any utilization other than the abovementioned, as well as any utilization that is not consistent with the technical data is taken as being not in accordance with the regulations. The operator bears the sole risk for any damage caused by such utilization.

2.4 Basic principles

The InTrac798 housing is built according to state-of-the-art technology and recognized technical safety regulations.

However, the housing can be a source of risks and dangers:

- when the housing is operated by insufficiently trained persons.
- when the housing is not used in compliance with the regulations.

InTrac798 may only be used in a technically perfect condition as well as in accordance with the regulations, with an awareness by the user of safety and danger factors, taking the operating instructions into account.

Malfunctions and damage that can affect the safety and function must immediately be remedied by the operator or an expert, and notified to the manufacturer in writing!

A defective retractable housing may neither be installed nor put into operation

2.5 Warning notices and symbols

The following symbols are used in this instruction manual to mark safety instructions:



DANGER!

Warning of a danger that can lead to extensive material damage, to death or grave bodily injury.



CAUTION!

Warning of a possible dangerous situation that can lead to light bodily harm and/or material damage.



INFORMATION!

Information leading to technical requirements. Non-adherence can lead to malfunctions, uneconomic working and possibly also to loss of productivity.

2.6 Responsibilities, organizational measures

Responsibility of the operator

- The operator is under obligation only to permit persons to work with InTrac798 who are familiar with the basic requirements of work safety and accident prevention, and who have been initiated into the handling of the housing. This instruction manual serves as the basic document.
- In addition to the instruction manual there are also generally valid legal and other binding regulations for work safety and accident prevention as well as for environmental protection, and these must be prepared by the operator and instructed to personnel using the housing.
- The operator/user must be fully aware of safety and potential danger factors during work with the housing and this awareness must be checked by the operator at regular intervals.
- Measures must be taken to ensure that the retractable housing is only operated in a safe and fully functional condition.

Responsibility of the personne

- All persons whose duty it is to operate the retractable housing are under obligation to read the Chapter on safety regulations and warning instructions in this instruction manual.

- In addition to the instruction manual, there are also generally valid legal and other binding regulations for work safety and accident prevention that must be adhered to.
- Any method of working which is doubtful from a safety perspective and which exceeds the operation according to regulations must be omitted.

Before every start-up, the retractable housing must be checked for:

- Damage to the connections, fastenings, etc.
- Leakage
- Perfect functioning

Personnel selection and qualifications – basic duties

- Working with InTrac may only be carried out by reliable and trained or instructed personnel. The personnel must have read the instruction manual.
- Clear responsibilities for the personnel, operating, servicing, repair, etc. must be provided.
- It must be ensured that only personnel whose specific duty it is, operate the housing.
- Personnel that are to be trained, instructed or who are being generally schooled may only be occupied at the housing under the constant guidance of an experienced person.
- High-pressure jets may not be used to clean polymer/plastic parts and components (of the housing)

2.7 Product-specific hazards

The thrust member may only be inserted into the housing together with an electrode and the corresponding cable. If there is no electrode or cable present, there may then be free passage for escape of sample medium.



CAUTION!

Escape of process medium can endanger the environment, personnel and material.

Before servicing work is carried out on the housing or before removing it, place the installation in which the retractable housing is mounted into a safe condition (depressurize, etc.). Disassembly of the housing may only be carried out after it has been dismantled from the process (vessel).

Only such servicing and repair work as is specifically described in this instruction manual may be carried out on the retractable housing.

Only original spare parts from METTLER Toledo may be used for replacing defective components (see Chapter 7.2 on «spare parts»).

2.8 Residual hazards

- Manipulations on the electrode may only be carried out when the retractable housing is in the maintenance condition.
- Manipulations on the housing may only be carried out when it is ensured that no product /sample medium, can exit through the housing due to an incorrect manipulation. For this reason, the whole system must first be drained and ventilated.
- The immersion tube must always be in one of the two defined positions:
«IN»: measuring, operating or inserted position
«OUT»: maintenance, withdrawn or retracted position.
- If the retractable member is between the defined **«IN»** or **«OUT»** positions, then no conforming measuring results can be ensured.
- When retracting the immersion tube from the process, small quantities of process medium will remain attached to the electrode and will thus enter the flushing chamber. If this medium is a poisonous or environmentally damaging substance, or contains pathogenic germs, then such contamination must be removed according to regulations!

- If the housing is not completely inserted, there will be a path for the process medium to enter the flushing chamber (due to the O-ring). This can lead to product loss or contamination.
- With the manually operated InTrac798, the retractable immersion tube can be pressed out of the process at increased velocity by the process pressure.
- With the pneumatic version, failure of the compressed air supply can result in the immersion tube being pressed out into the maintenance position. This makes continuous measurement impossible.
- Before the electrode and thrust member are loaded into the pneumatic version of the InTrac798, it must be ensured that the setting of the pneumatic valves that control the position of the housing are set to the maintenance position. Incorrect setting can cause the housing to insert into the process before the loading procedure has been completed, resulting in open access to the measuring medium.
- The housing is not equipped with heat protection. During steam-sterilization procedure, the surface of the housing can reach high temperatures.

2.9 Emergency measures

Always observe and comply with local regulations!

2.10 Safety measures

The local laws and regulations must always be adhered to. They are not part of this instruction manual. Basically it is necessary to wear personal protective equipment such as goggles, as well as protective clothing.

The operator is responsible for instruction of the personnel. For this reason, the instruction manual can also be ordered in other languages. This instruction manual must be considered to be a part of the housing, and be available at all times to the operating personnel at the point of operation of the housing.

The operator should immediately inform the manufacturer of all safety-relevant events that occur during the operation of the housing.

2.11 Modifications

Modifications to the housing are only permitted after consultation with, and written permission from, the manufacturer.

No unauthorized attachments or modifications to the retractable housing and the accessories are allowed. The manufacturer/supplier accepts no responsibility for any damage caused by unauthorized attachments and alterations or for the incorporation of spare parts which are not of METTLER TOLEDO provenance. The risk is borne entirely by the operator.

3 Product description

3.1 Uses and features

InTrac 798 is a housing for the installation of electrodes with a 12 mm shaft diameter. It enables the electrode to be withdrawn for maintenance purposes while the process is running or during cleaning phases with CIP solutions, in order to be able to protect the electrodes from negative influences.

3.2 Function of the flushing chamber

In the maintenance mode in the flushing chamber, the measuring tip of the electrode can be cleaned by flushing and steam-sterilizing. The two connections guarantee differentiated flow to the immersion tube and the electrode.

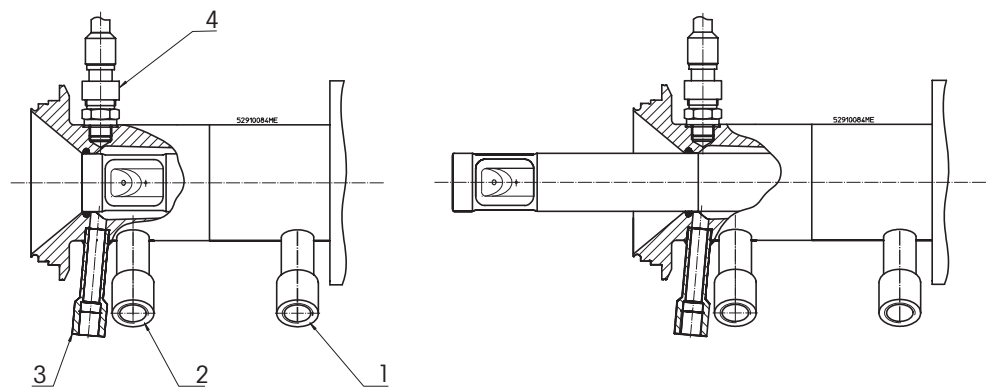

Rear flushing connection [1]:

The rear flushing connection directs the cleaning medium or the steam tangentially to the immersion tube.

Front flushing connection [2]:

The front flushing connection directs the cleaning medium or the steam directly to the tip of the electrode. This ensures optimal cleaning.

Outlet flushing chamber [3]:

The outlet of the flushing chamber has a very small diameter. When installing the housing, it must be ensured that the outlet always faces downwards.

Temperature connection [4]:

The flushing chamber is equipped with an additional thread for a temperature probe. This temperature probe may only be used for checking the sterilization temperature.



Safety instruction

All valves must be closed during insertion and withdrawal of the immersion tube of the retractable housing as otherwise the contents of the reactor can escape via the flushing chamber.

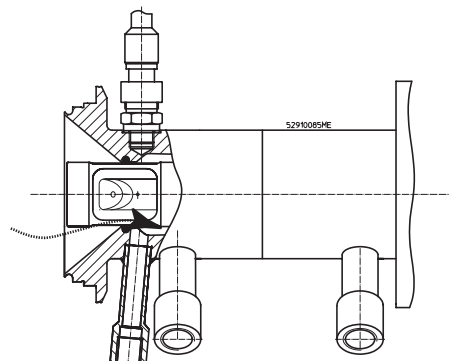

3.3 Function of the manual retractable housing (InTrac798-M)

In manual operation, the immersion tube is brought into the desired position by operating the locking pin. The housing is in a defined position only when the locking pin clicks home.

- «IN»: Measuring or operating or inserted position.
- «OUT»: Maintenance or withdrawn or retracted position.

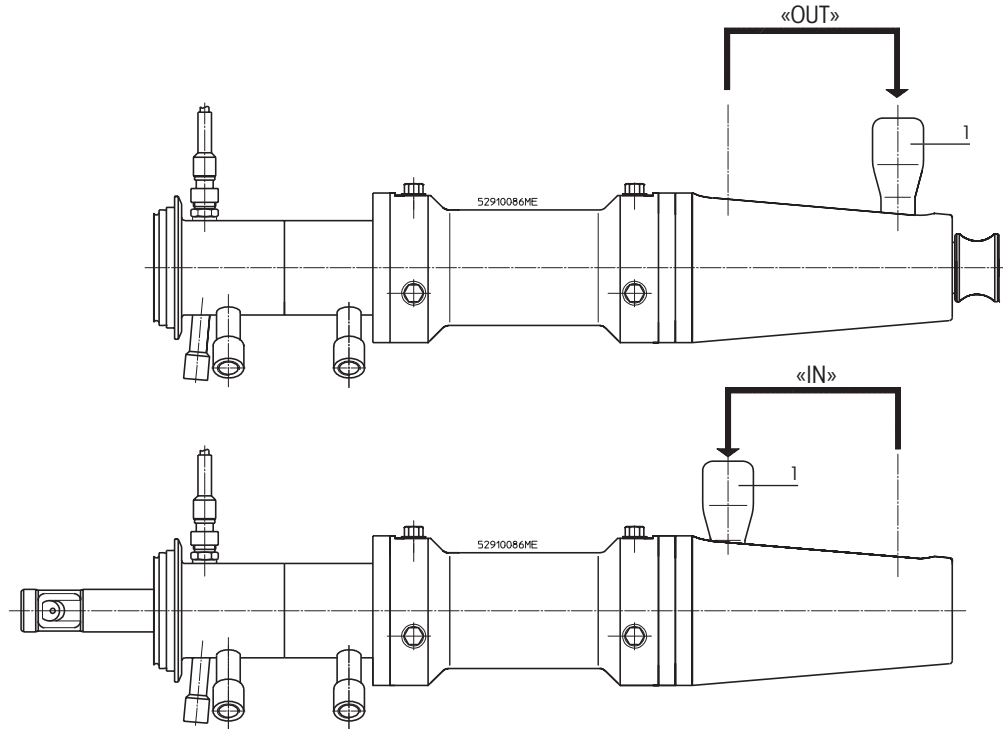

[1] «Locking pin»

Inserting and withdrawing the immersion tube of the retractable housing

Pull out the locking pin and move the immersion tube by hand into the other position. Different counter-pressures must be overcome because of the different forces exerted by the O-rings. When the end position has been reached, make sure that the pin locks in again securely.

3.4 Function of the pneumatic retractable housing (InTrac798-P)

In pneumatic operation, the immersion tube is moved into its desired position by means of compressed air.



DANGER / INFORMATION

- Loss of control air pressure or solid particles (e.g. dust) in the compressed air must be avoided since the immersion tube could otherwise be blocked in an undefined (intermediate) position. If the immersion tube takes up an undefined position between «IN» and «OUT», then process medium can escape between the lower section of the flushing chamber and the flushing pipes.
- Before insertion of the immersion tube, ensure that besides the thrust member, the electrode and the cable have also been loaded.
- Installation of an alarm should be considered in order to register a pressure drop or a complete loss of pressure.

4 Installation and start-up

4.1 Mounting position of the retractable housing

The retractable housing is side-mounted into a vessel through a 15° inclined weld-in socket or through an appropriate flange.

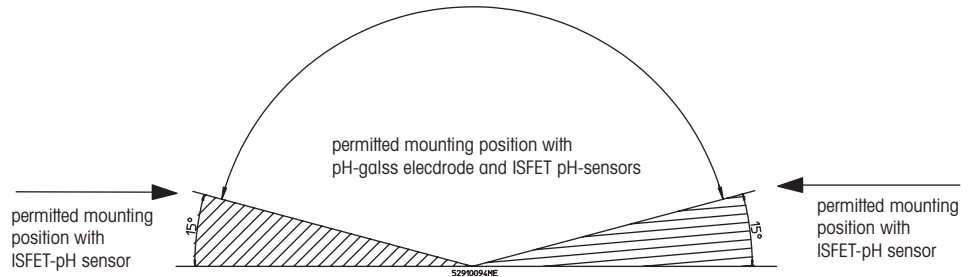

The following alternative adaption methods are offered as standard.

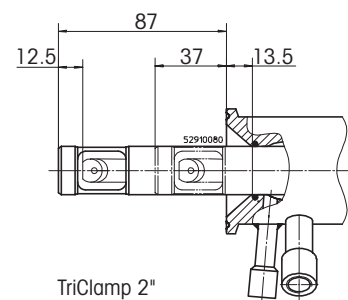
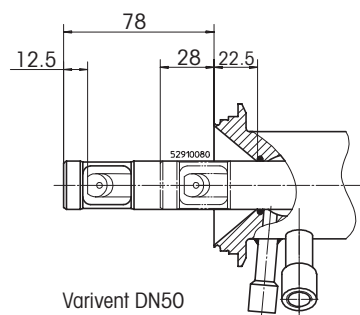
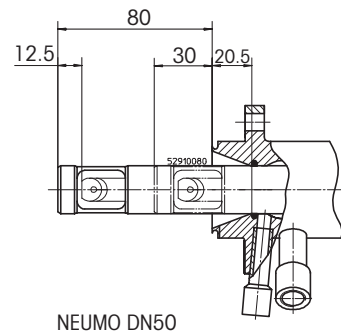
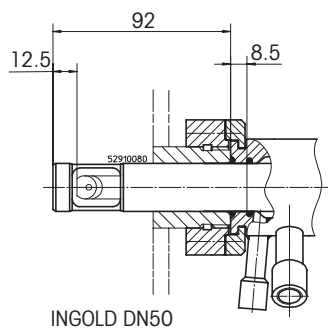

4.2 Calibration of the pH electrode or the transmitter

See instruction manuals for the electrode and the transmitter.

4.3 Fitting of the electrode into the retractable housing

1. Withdraw the movable part of the housing.
2. Release thrust member (press and rotate → Bayonet lock).
3. Connect electrode to the cable.
4. Insert cable into the thrust member.
5. Press thrust member accurately onto the end of the plug.
6. Fix the cable with its accompanying screw connection to the thrust member (not for ISFET cables).
7. Load the electrode and thrust member together as a unit into the housing, pushing from the rear.
8. When loading, the position of the sensor (ISFET – surface) can be determined by rotation.
9. Securely fix the thrust member.
10. For ISFET cables: fit the amplifier. (Clips including fixing screw are included in the delivery see housing packaging)

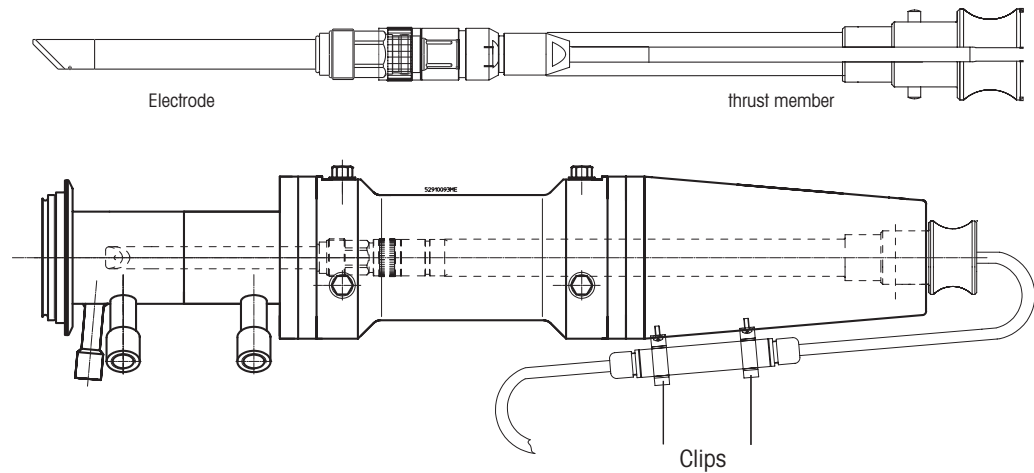

«Loading the electrode»

4.4 Removing the electrode from the retractable housing

1. Retract the immersion tube.
2. Loosen thrust member.
3. Pull thrust member and cable together out of the housing.
4. Disconnect electrode.



NOTE:

In an emergency following breakage of an electrode, the immersion tube can be unscrewed apart (at Pos. 1). **Attention:** neither the bore nor the surface of the immersion tube may suffer any damage.

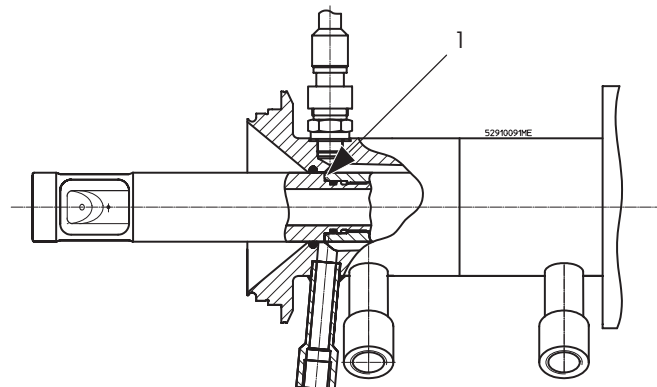

4.5 Mounting the retractable housing

1. Move housing into the measuring position (especially important when mounting through an INGOLD weld-in socket).
Attention: the bore of the weld-in socket must be greater or equal to \varnothing 25 H7
2. Mount the InTrac798 at the process adapter.
3. Connect steam or flushing lines.
4. Move the housing into the maintenance position
5. Fit the electrode according to «Chapter 4.3».

4.6 Removing the retractable housing



Safety instruction

Before removing the retractable housing, ensure that the reactor (pipe) is empty and not pressurized, and if necessary, that it has also been cleaned/flushed.

1. Close all valves.
2. Retract the immersion tube (→ maintenance).
3. Rinse the flushing chamber for some seconds with cleaner (possibly condensate, steam).
4. Remove electrode.
5. Shut off compressed air and steam lines.
6. Remove hoses and pipes.
7. Remove housing from the process adapter.
8. Store housing in a dry place.

4.7 Connecting the sterilization or flushing lines

The housing is delivered without blind screws. It is important to make certain that the outlet from the flushing chamber always faces downwards.



Safety instructions

- We recommend stainless steel pipes of size 6/4 mm for the supply and return lines. Long lines of this size must, however, be avoided.
- Steam lines should be insulated in order to protect the user from burns and to prevent excessive heat loss.
- It is recommended to connect a line for sterile air to the flushing chambers.
- We recommend to fit pressure reduction valves in the feed pipes in order to be able to control the pressure distribution (at the two entries to the flushing chamber)

5 Operation

5.1 Sterilization of the electrode

5.1.1 General

The electrode can either be sterilized in the inserted position in the reactor (see Chapter 5.1.2) or, to provide longer life, under controlled conditions in the flushing chamber. If sterilization is carried out in the inserted condition, the flushing chamber must also be sterilized in order to provide the best possible sterile conditions.

We recommend that a sterilization procedure is selected in which the electrode is subjected to the least possible temperature shocks. As a negative example, the insertion of a steam-heated electrode into a cold reactor places excessive stress on the electrode.

The following Chapters 5.1.2 and 5.1.3 describe the sterilization of the electrode with a minimum effort of valves and piping. We recommend that the steam feed line be provided with a sterilizable filter through which the flushing chamber can be ventilated during cooling down from steam temperature. For applications in media containing solid particles, we recommend the installation of a flushing line.

5.1.2 Sterilization of the electrode in the reactor

1. Fit the electrode in accordance with «Chapter 4.3».
2. Mount housing in accordance with «Chapter 4.5».
3. Insert immersion tube of the housing.
4. Sterilize the electrode.
5. During sterilization in the process, the flushing chamber and the immersion tube must also be sterilized.
6. Clean with steam through the rear flushing connection until the flushing chamber is hot.
7. Monitor the temperature and the sterilization time.
8. Ventilate flushing chamber with sterile air.
9. Calibrate electrode according to requirements.

5.1.3 Sterilization of the electrode in the flushing chamber

1. Fit the electrode in accordance with «Chapter 4.3.»
2. Mount the housing in accordance with «Chapter 4.5.»
3. Sterilize the electrode in the flushing chamber. Heat with steam until the flushing chamber is hot.
4. An external temperature sensor can be connected to the flushing chamber for checking its temperature.
5. Monitor the temperature and the sterilization time.
6. Ventilate flushing chambers (if possible through a sterile filter)
7. Insert the immersion tube together with the electrode into the sterile reactor.
8. If, necessary, repeat sterilization process for the flushing chamber including the rear part of the immersion tube.

5.2 Removing the electrode without interrupting the process

1. Close all valves.
2. Retract the immersion tube from the process.
3. Rinse the flushing chamber and electrode for some seconds with a cleaner and/or condensate/steam.
4. Remove electrode.



Safety instructions

Because the immersion tube will insert when the thrust member is loaded, it must be ensured that the thrust member is not inadvertently loaded and insertion of the immersion tube initiated.

5.3 Installing the electrode without interrupting the process

See «Chapter 4.3».

6 Maintenance

6.1 Calibration intervals of pH electrodes

The frequency of calibration depends on the required measuring accuracy and the process conditions. We recommend that the electrode is calibrated at the start of the application. If process influences do not cause any changes in zero point and slope, then the sensor should be (re-)calibrated as seldom as possible.

6.2 Cleaning the electrode

Whenever it is retracted (maintenance or withdrawn position), the electrode should be cleaned for some seconds.

**Caution!**

When retracting the immersion tube, small quantities of process medium will remain attached to the electrode and will thus enter the front flushing chamber. If this medium is a poisonous or environmentally damaging substance or contains pathogenic germs, then these must be removed according to regulations!

6.3 Storing the electrode

For pH electrodes the electrode tip should either be stored in the watering cap filled with a reference electrolyte or, in the event that the electrode is built into the housing, in the flushing chamber filled with water or a buffer solution.

**NOTE:**

In order to prevent escape of water or buffer solution, the outlet of the flushing chamber should be equipped with a valve.

6.4 Changing the O-rings

The frequency of O-ring replacement depends on how frequently the immersion tube is inserted and withdrawn, and on the degree of compatibility of the wetted O-rings with the process medium.

7 Product specifications

7.1 Technical data InTrac 798-M / InTrac 798-P

| | | |
|---------------------------------------|---|--|
| Environment conditions | Temperature | 0...70 °C |
| Process conditions | Temperature range Function, pressure range Max. permissible pressure | 0...140 °C InTrac798M: 0...5 bar InTrac798P: 0...8 bar 16 bar |
| Technical information | Standard process adapter | INGOLD DN25 Neumo DN50 Varivent DN50 TriClamp 2" |
| Wetted parts | 1.4404 EPDM-FDA Food-grade lubricants | Klüber, Paraliq GTE703 / FDA |
| Non-wetted parts | 1.4305 PTFE PA | |
| Weight | approx. 6.5 kg | |
| Dimensions | Length: Length: | approx. 490 mm in measuring and maintenance position 880 mm for electrode removal (minimum) |
| Pneumatic connections | 4...8 bar | |
| Air quality to ISO 8573-1 | Air moisture content class 4 Solids class 5 max. oil content class 2 Air connections for hoses | dew point +3 °C filter 40 mm 0.1 mg/m ³ 6/4 mm |
| Flushing connections | Water, steam 2 x Connection « IN »: 1 x Connection « OUT »: | 2...6 bar thread G 1/4" female thread G 1/8" female |
| Position monitoring (optional) | pneumatic check-back Inductive check-back (both threads integrated) | 3/2 way valve; G 1/8" Non-Ex, M12 x1 |
| Temperature probe (optional) | Pt100 or Pt1000 | Threaded port G1/8" already present in flushing chamber |

| | |
|-----------------------------|--|
| Pressure information | According to PED-Article 1, Section. 2.2, «Pressure» is referenced to atmospheric pressure, e.g. an overpressure. Accordingly, a pressure in the vacuum region will be expressed as a negative pressure. |
|-----------------------------|--|

7.2 Spare parts / ordering information

| Designation | Order no. |
|--|----------------|
| InTrac 798 M 100 4404 ING025 EP _ VPP _ _ | 52 402 764 |
| InTrac 798 P 100 4404 ING025 EP _ VPP _ _ | 52 402 766 |
| InTrac 798 M 100 4404 NEU050 EP _ VPP _ _ | 52 402 768 |
| InTrac 798 M 050 4404 NEU050 EP _ VPP _ _ | 52 402 769 |
| InTrac 798 P 100 4404 NEU050 EP _ VPP _ _ | 52 402 770 |
| InTrac 798 P 050 4404 NEU050 EP _ VPP _ _ | 52 402 771 |
| InTrac 798 M 100 4404 TC-2,0 EP _ VPP _ _ | 52 402 772 |
| InTrac 798 M 050 4404 TC-2,0 EP _ VPP _ _ | 52 402 773 |
| InTrac 798 P 100 4404 TC-2,0 EP _ VPP _ _ | 52 402 774 |
| InTrac 798 P 050 4404 TC-2,0 EP _ VPP _ _ | 52 402 775 |
| InTrac 798 M 100 4404 VAR050 EP _ VPP _ _ | 52 402 776 |
| InTrac 798 M 050 4404 VAR050 EP _ VPP _ _ | 52 402 777 |
| InTrac 798 P 100 4404 VAR050 EP _ VPP _ _ | 52 402 778 |
| InTrac 798 P 050 4404 VAR050 EP _ VPP _ _ | 52 402 779 |
| Pt100-764/5 m | 10 1003 104 IG |
| Pt1000-764/5 m | 10 1003 116 IG |
| Check-back indication set non-EEEx (2 pcs.), inductive | 52 402 398 |
| 3/2-way indication valve set (2 pcs.), pneumatic | 52 401 324 |

| Spare parts / designation | Order no. |
|----------------------------|------------|
| Sealing set 798P | 52 402 789 |
| Sealing set 798M | 52 402 790 |
| Safety system 798 complete | 52 402 791 |
| Pressure plate | 52 402 824 |

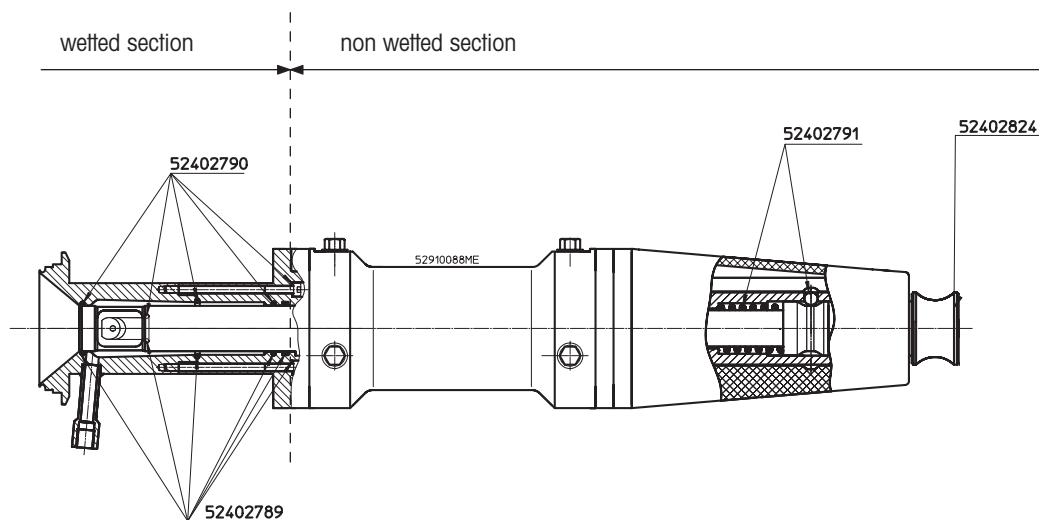

7.3 Installation of the safety system InTrac798



Safety instructions

Before removing the retractable housing, ensure that the reactor (piping) is empty and no longer under pressure and, if necessary, that the housing has also been cleaned.

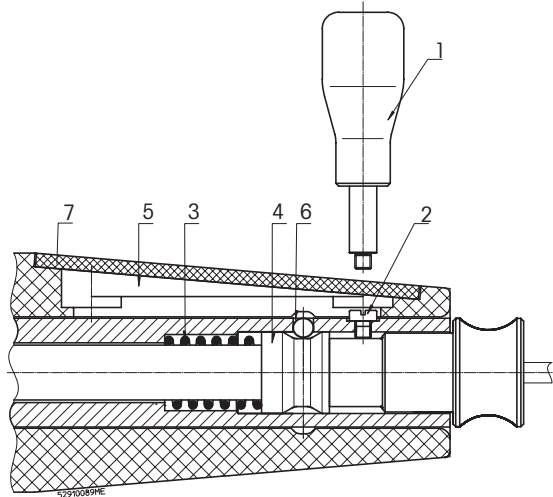

Removal

1. Move housing into the maintenance position.
2. Empty reaction vessel and de-pressurize.
3. Pull thrust member, cable and electrode out of the housing.
4. For manual version, loosen grip [1].
5. For pneumatic version, loosen cover plate [7] and fixing screw [2].
6. Remove complete safety system.
(spring [3], slider [4] and balls)

Installation

7. Install new spring [3].
8. Insert slider [4].
9. Press slider down with thrust member and clip in (finalize thrust member installation).
10. Rotate thrust member and immersion tube until the hole [5] for the ball is visible through the side opening [6].
11. Insert first ball.
12. Turn 1/3 rotation, clockwise.
13. Insert 2nd ball.
14. Turn 1/3 rotation, clockwise
15. Insert 3rd ball.
16. Turn thrust member further until the thread of the screw [2] is visible.
17. Screw in grip [1] or fixing screw [2] and hand-tighten.
18. Install plate [7] cover (for pneumatic version only).

7.4 Installation of the sealing set InTrac 798



Safety instructions

Before removing the retractable housing, ensure that the reactor (piping) is empty and no longer under pressure and, if necessary, that the housing has also been cleaned.

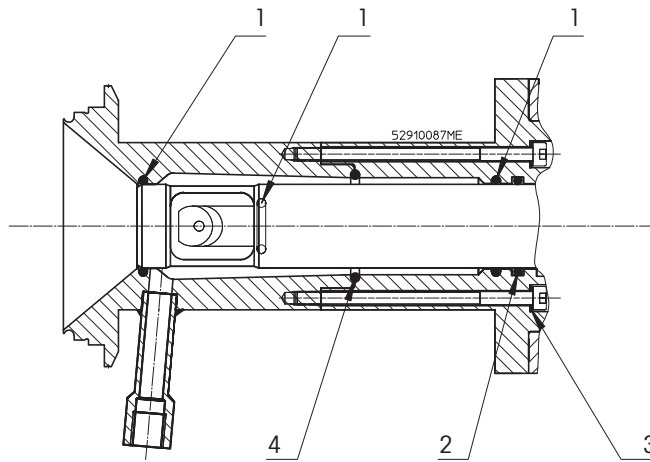

Removal

1. Move housing into the maintenance position.
2. Empty reaction vessel and de-pressurize.
3. Loosen flushing chamber from the guide cylinder
4. Remove flushing chamber.
5. Replace O-rings [1] according to the drawing (for pneumatic version an O-ring [2] for cylinder sealing is also supplied).
6. Place washers [3] on screws (ensure that old, squashed washers are removed from the grooves).
7. Install O-ring [4] for sealing the 2-part flushing chamber and assemble flushing chamber. Hand-tighten screws.
8. Install flushing chamber and tighten.



NOTE:

O-rings to be well greased before fitting → use food-grade lubricant

7.5 Fitting of 3/2-way check-back position indicator

1. Remove screw plug [1]

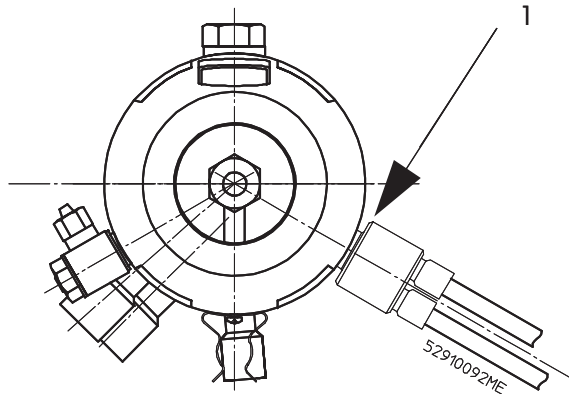

2. Screw in the check-back indicator
3. Attach pneumatic hoses

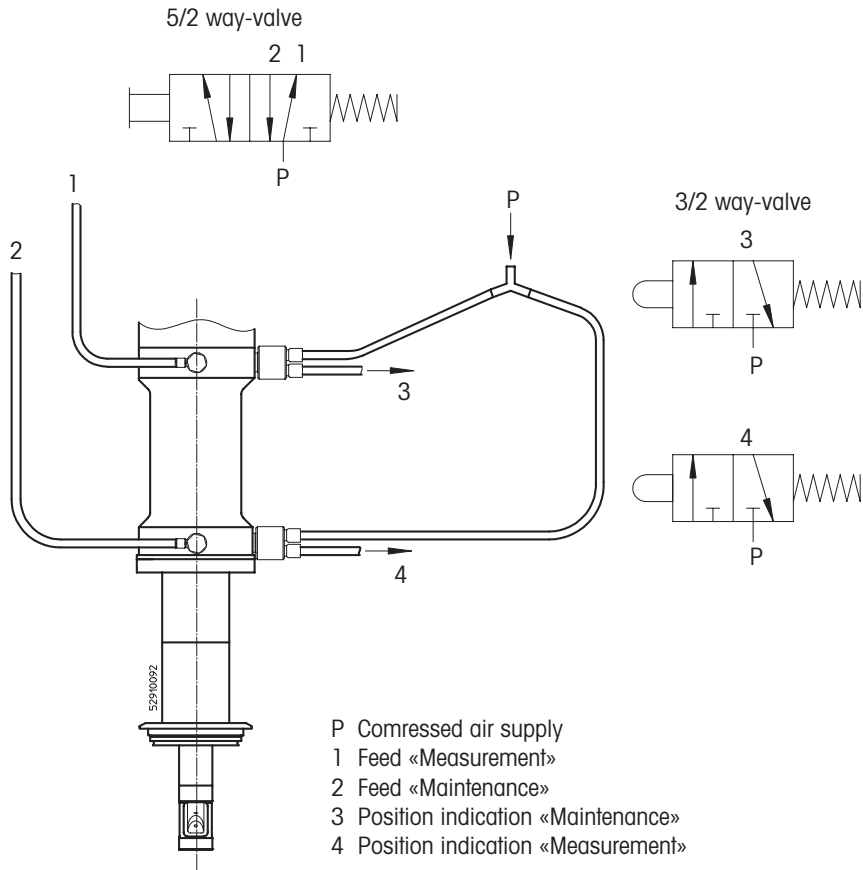

NOTE:

The permitted operating pressure of the pneumatic system is max. 8 bar.
 The pressure in the control supply for the housing must be at least min. 4-4.5 bar.
 The control air must be oil-free, and filtered.
 When using a P/E transducer: adjust response pressure between 3-4 bar.

7.6 Fitting of non-Ex inductive check-back position indicator

1. Remove screw plug [2].

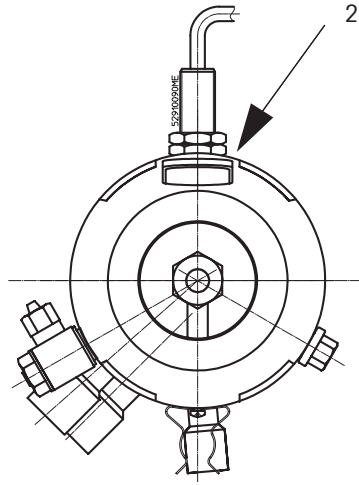

2. Screw in the check-back indicator with Loctite 577.

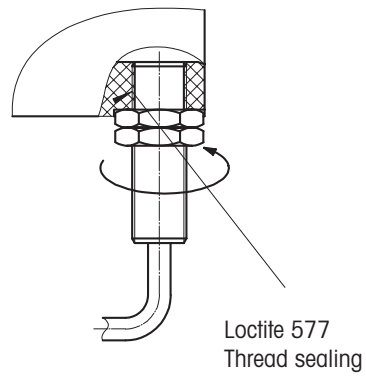

3. Unscrew the check-back indicator 0.5 mm back.

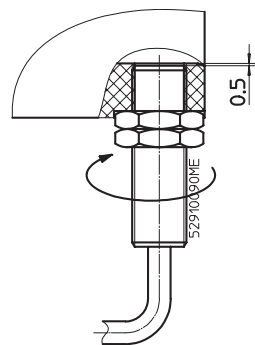

8 Decommissioning, storage, disposal

**DANGER**

Please refer to Chapter 2 «Safety».

Decommissioning may only be performed by trained staff or specialists.

8.1 Decommissioning

Procedure as described in Chapter 4.6 «Removing the retractable housing».

8.2 Storage

Store the housing in a dry place.

8.3 Disposal

It is recommended that the operator disposes of the device in accordance with local regulations. The operator must deliver the device to either a licensed private or a public disposal company or dispose of it himself in accordance with prevailing regulations. Waste is to be recycled or disposed of without causing any risk to human health and without using procedures or methods that might damage the environment.

| | |
|--------------|------------|
| EC guideline | 75/442/EEC |
| | 91/156/EEC |

Sorting

Sorting into waste groups takes place when dismantling the device. The groups are listed in the current European Waste Catalog (EWC). This catalog is valid for all waste, whether it is intended for disposal or for recycling.

The packaging contains the following materials:

- cardboard
- foam plastic.

The device contains the following materials:

- steel, PA, EPDM (O-rings)

Sales and Service:
Australia

Mettler-Toledo Ltd.
220 Turner Street
Port Melbourne
AUS-3207 Victoria
Phone +61 39 644 57 20
Fax +61 39 645 39 35
e-mail mtausprocess@mt.com

Austria

Mettler-Toledo GmbH
Favoritner Gewerbering 17
A-1100 Wien
Phone +43 1 604 19 80
Fax +43 1 604 28 80
e-mail info@process.mtat@mtf.com

Brazil

Mettler-Toledo Ind. e Com. Ltda.
Alameda Araguaia
451 - Alphaville
BR-06455-000 Barueri/SP
Phone +55 11 4166 74 00
Fax +55 11 4166 74 01
e-mail sales@mettler.com.br
service@mettler.com.br

China

Mettler-Toledo Instruments
(Shanghai) Co. Ltd.
589 Gui Ping Road
Cao He Jing
CN-200233 Shanghai
Phone +86 21 64 85 04 35
Fax +86 21 64 85 33 51

Croatia

Mettler-Toledo d.o.o.
Mandlova 3
HR-10000 Zagreb
Phone +385 1 292 06 33
Fax +385 1 295 81 40
e-mail mt-zag@zg.tel.hr

Czech Republic

Mettler-Toledo s.r.o.
Trebohosticka 2283/2
CZ-10000 Praha 10
Phone +420 2 72 123 151
Fax +420 2 72 123 170
e-mail sales.mtcz@mtf.com

Denmark

Mettler-Toledo A/S
Naverland 8
DK-2600 Glostrup
Phone +45 43 27 08 00
Fax +45 43 27 08 28
e-mail mtdk@post10.tele.dk
lsl@mts.mt.com

France

Mettler-Toledo
Analyse Industrielle Sarl.
30, Boulevard Douaumont
BP 949
F-75829 Paris Cedex 17
Phone +33 1 47 37 06 00
Fax +33 1 47 37 46 26
e-mail mtpro-f@mtf.com

Germany

Mettler-Toledo GmbH
Prozeßanalytik
Ockerweg 3
D-35396 Gießen
Phone +49 641 507 333
Fax +49 641 507 397
e-mail prozess@mtf.com

Great Britain

Mettler-Toledo LTD
64 Boston Road Beaumont Leys
GB-LE4 1AW Leicester
Phone +44 116 235 7070
Fax +44 116 236 5500
e-mail enquire.mtuk@mtf.com

Hungary

Mettler-Toledo Kereskedelmi KFT
Teve u. 41
HU-1139 Budapest
Phone +36 1 288 40 40
Fax +36 1 288 40 50

Italy

Mettler-Toledo S.p.A.
Via Vialba 42
I-20026 Novate Milanese
Phone +39 02 333 321
Fax +39 02 356 2973
e-mail mettler.toledo@interbusiness.it

Japan

Mettler-Toledo K.K.
5F Tokyo Ryutsu Center Annex B
6-1-1 Heiwajima, Ohta-ku
JP-143-0006 Tokyo
Phone +81 3 5762 07 06
Fax +81 3 5762 09 71

Mexico

Mettler-Toledo S.A. de C.V.
Pino No. 350, Col. Sta.
Col Atlampa
MX-06450 México D.F.
Phone +52 5 541 33 00
Fax +52 5 541 04 02
e-mail mario.roca@mtf.com

Poland

Mettler-Toledo (Poland) Sp.z.o.o.
ul. Iwonicka 39
PL-02-924 Warszawa
Phone +48 22 651 92 32
Fax +48 22 651 71 72

Russia

Mettler-Toledo ZAO
Sretenskij Bulvar 6/1
Office 6
RU-101000 Moscow
Phone +7 095 921 92 11
Fax +7 095 921 63 53
+7 095 921 78 68

Singapore

Mettler-Toledo (S) Pte. Ltd.
Block 28
Ayer Rajah Crescent #05-01
SG-139959 Singapore
Phone +65 890 00 11
Fax +65 890 00 12
+65 890 00 13

Slovakia

Mettler-Toledo SERV s.r.o.
Bulharska 61
SK-82104 Bratislava
Phone +421 743 42 74 96
Fax +421 743 33 71 90

Slovenia

Mettler-Toledo d.o.o.
IOC Trzin, Peske 12
SI-1236 Trzin
Phone +386 61 162 18 01
Fax +386 61 162 17 89
e-mail cipot@mtslo.mt.com
racman@mettler-toledo.si

Sweden

Mettler-Toledo AB
Virkesvägen 10
Box 92161
SE-12008 Stockholm
Phone +46 8 702 50 00
Fax +46 8 642 45 62
e-mail sales.mts@mtf.com

Switzerland

Mettler-Toledo (Schweiz) AG
Im Langacher
Postfach
CH-8606 Greifensee
Phone +41 1 944 45 45
Fax +41 1 944 45 10
e-mail info.ch@mtf.com

Thailand

Mettler-Toledo Thailand
1. Floor, 272 Block A3
Raintree Office Garden
Rama 9 Rd. Kuay Kwang
TH-10310 Bangkok
Phone +66 2 723 03 00
Fax +66 2 719 64 79

USA

Mettler-Toledo
Ingold, Inc.
36 Middlesex Turnpike
Bedford, MA 01730, USA
Phone +1 781 301-88 00
Toll free +1 800 352 8763
Fax +1 781 271-06 81
e-mail mtprous@mtf.com



Management System
certified according to
ISO 9001 / ISO 14001



INTERNET

<http://www.mtpro.com>

Subject to technical changes.
© Mettler-Toledo GmbH, Process Analytics
11/02 Printed in Switzerland. 52 402 788

Mettler-Toledo GmbH, Process Analytics
Industrie Nord, CH-8902 Urdorf
Tel. + 41 1 736 22 11, Fax +41 1 736 26 36