

METTLER TOLEDO

Operating instructions
METTLER TOLEDO
Piece counting CountR+

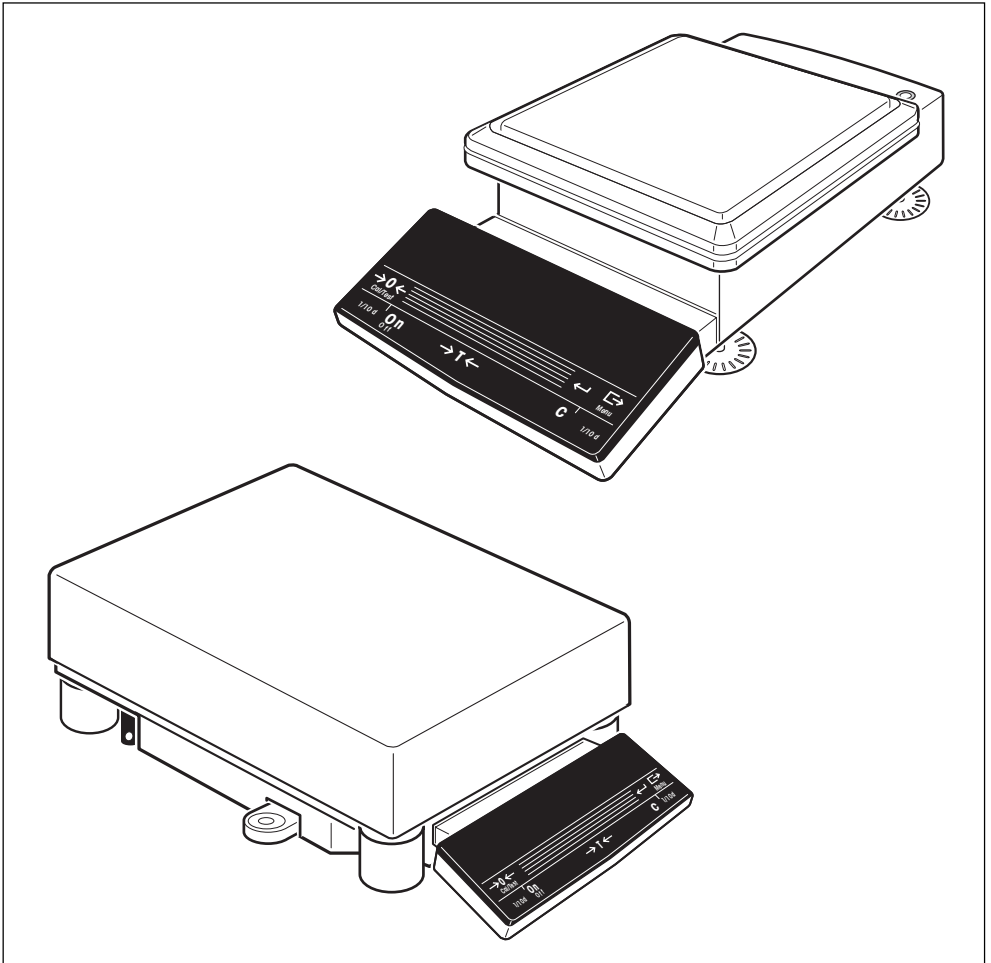

Contents

1.	Important information before you start	3
1.1	Introducing CountR+	3
1.2	What you should know about these instructions	3
1.3	Safety has priority	3
2.	Installation of the application cassette	4
3.	The menu of CountR+	4
4.	First-time startup and language selection	6
5.	Important information on reference determination	6
6.	Performing a simple piece counting	7
7.	Extended counting functions	11
7.1	Overview of the extended functions	11
7.2	Reference optimization	11
7.3	Fixed, user reference piece number	12
7.4	Totalization	13
7.5	Portion counting	14
7.6	Working with a second weighing instrument	16
7.7	Storing and recalling references	18
7.8	Combining the extended functions	21
8.	Making printed records of counting operations	23
8.1	Activating the order identifications and free texts	23
8.2	Working with order identifications	25
8.3	Activating the consecutive serial number	26
8.4	Selecting the data for the printed record	27
8.5	Settings for the label printer	28
9.	Transmitting commands to an external instrument	29
10.	Printing out the balance settings	31
11.	Appendix	32
11.1	Optional equipment and system overview	32
11.2	SICS commands	33

1. Important information before you start

Thank you for purchasing the CountR+ software for METTLER TOLEDO PR/SR balances. This section provides you with basic information regarding CountR+.

1.1 Introducing CountR+

CountR+ turns your PR/SR balance into a customized counting balance which can be optimally configured for your requirements and work routines. In addition to the general functions described in the operating instructions of your PR/SR balance, CountR+ offers you the following possibilities:

- An integrated database for the storage of up to 250 reference weights (with article designation and, if need be, a tare weight), which can be recalled at any time. There is a special function you can use to transmit commands to an external instrument so you can, for example, access the database on a computer.
- Freely definable headers and texts for even more informative records. For reports and labels there is a wide range of layout and formatting options (typefaces, bar codes).
- Attachment possibility for a second weighing instrument for reference determination or counting.
- Extended counting functions, which can be combined with additional functions (totalization, portion counting).

1.2 What you should know about these instructions

These instructions presuppose that you are familiar with the operation and the menu of the PR/SR balance. Functions and work steps already described in the operating instructions of the METTLER TOLEDO PR/SR balances are repeated in the present instructions only in exceptional cases. We thus advise you to keep the instructions of your PR/SR balance ready to hand at all times.



With an optional bar-code scanner you can read in identifications (order, article, lot, etc.) in a simple manner. Functions which can be executed with the scanner are marked by the symbol opposite.

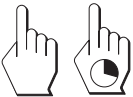

In the operation of the PR/SR balance, a distinction is made between a brief and a long keystroke. In these instructions, the empty hand shown on the left indicates a brief keystroke, whereas the hand on the right with superimposed clock symbolizes pressing and holding a key.

1.3 Safety has priority



Please ensure that you read and comply with all cautionary notes listed in the operating instructions of your PR/SR balance. They are marked by the symbol opposite!

2. Installation of the application cassette

Before you can work with CountR+, you must install the application cassette in your PR/SR balance. Proceed as follows:

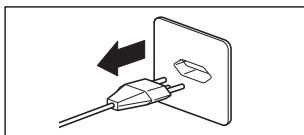

- Disconnect the balance from the power supply.

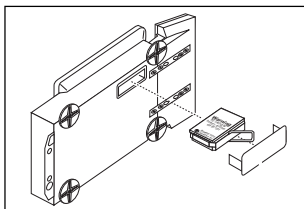

The illustrations opposite show the installation of the application cassette (top illustration: PR balance, bottom illustration: SR balance).

- The cassette slot is located on the underside of the balance. Turn the balance over and remove the cover of the cassette slot (also the cover seal in the case of an SR balance).
- If a cassette is already installed, hold it by the clip and pull it out of the slot.
- Push the CountR+ application cassette into the slot (it is impossible to insert it wrongly) and push the clip down.
- Replace the cover of the cassette slot (and the cover seal in the case of an SR balance).
- Reconnect the balance to the power supply.

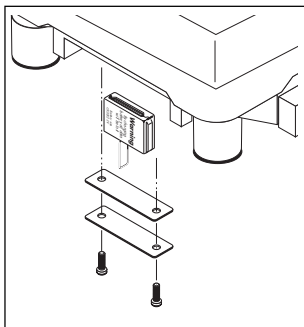

Important information

- Older PR/SR balances with combined $\rightarrow O/T \leftarrow$ key are not supported.
- The version of the terminal software must be 2.10 or higher.

3. The menu of CountR+

Changing the application cassette also changes some parts of the menu of your PR/SR balance:

- The main menu "COUNT", which contains the counting functions, appears in place of the menu "APPL".
- The contents of the main menus "WEIGH" and "CAL" are unchanged. Adjustment can be performed manually between two counting operations.
- In the main menu "SYSTEM", the menu "PrintOut" is replaced by the menu "Header" in which you can enter identifications and texts. There is an extra "Data" menu where you can specify which data should be transmitted and how it should be formatted. The remaining menus of "SYSTEM" are unchanged.
- In the main menu "LANGUAGE", you have a choice between English, German, French, Spanish and Italian.
- In the main menu "LABEL", you select the label printer and various output options.

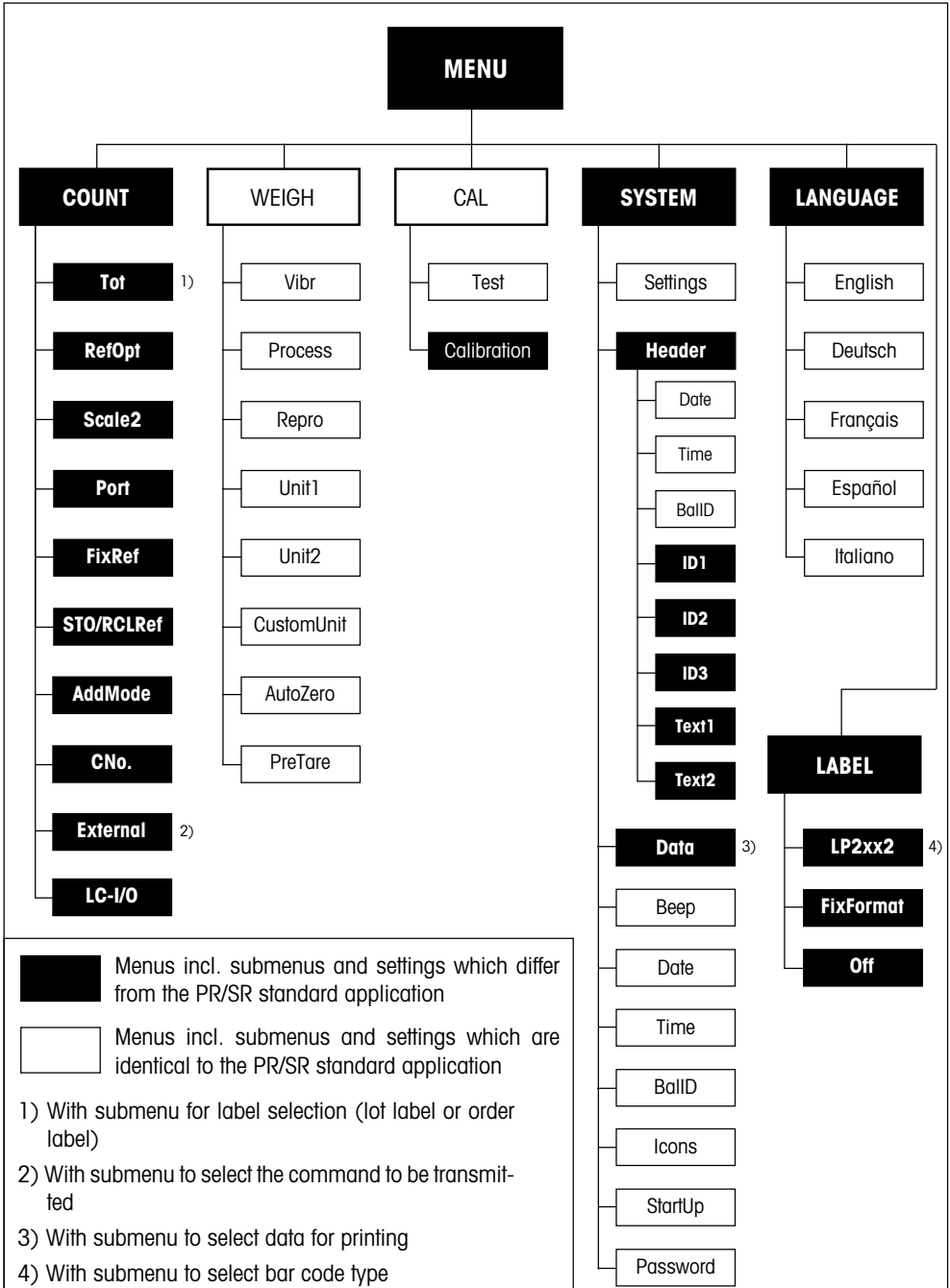

4. First-time startup and language selection

The first time you switch on the balance after installing the CountR+ application cassette (see section 2), the main menu for selection of the dialog language is shown directly.



- English is set in the factory as the dialog language. Select the language you require.



- Changeover is effected immediately. Store your setting and quit the menu.

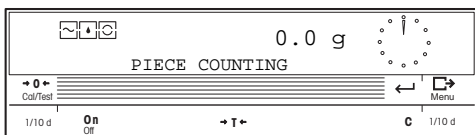

Your balance is now ready for weighing or piece counting.

Note: In all subsequent startup operations, you no longer have to select the language. After switching on, the balance is directly ready for weighing or piece counting in the language you have selected. **You can use the menu to select another language whenever you wish.**

5. Important information on reference determination

Before piece counting can be performed, each counting application requires a reference weight. Determination of this **reference** is always the first step in any new counting operation. CountR+ offers you various possibilities to determine the reference weight and these are described in the next section.

For correct determination of a reference, please observe the following instructions:

- In all cases, we advise you to select a **reference piece number as large as possible** as CountR+ determines the average weight per piece. As the individual pieces do not always have exactly the same weight, the accuracy of the reference weight increases with increasing size of the reference piece number.
- In **reference determination and piece counting on the PR/SR balance**, the minimum weight of a reference piece must not be less than 0.25d (1d = smallest display increment) and the reference quantity must be at least 10d.
- If a **second weighing instrument is used for reference determination and the PR/SR balance for counting**, the minimum weight of a reference piece must not be less than 0.001d, referred to the PR/SR balance.

- If the minimum reference quantity of 10d is not reached, CountR+ activates the so-called **Add mode** (this function is switched off in the factory), which prompts you to place additional pieces on the pan:
 - If the reference quantity lies between 2.5d and 10d, you are prompted to place **20 additional pieces** on the pan. Load the additional pieces and confirm the loading by pressing the SmartBar. After determination of the reference, the balance returns to the weighing mode. If you do not place any additional pieces on the pan and quit the Add mode by pressing the “->0<-” key, you can continue working but with a reduced accuracy (signalled by the asterisk symbol in the display).
 - If the reference quantity is less than 2.5d, a message appears indicating that the **value is illegal**. In this case, determination of the reference is not possible.
 - The reference weight last determined remains stored in the balance on power failure.

6. Performing a simple piece counting

CountR+ is preset in the factory for simple piece counting. You will find the extended functions for piece counting in section 7.

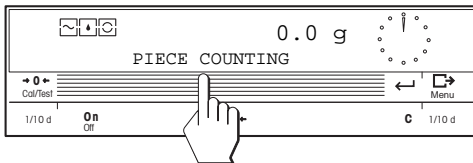

- After startup, the balance is in the weighing mode. Switch to the counting mode.

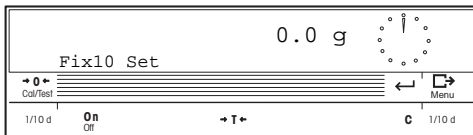

The balance is now ready for piece counting.

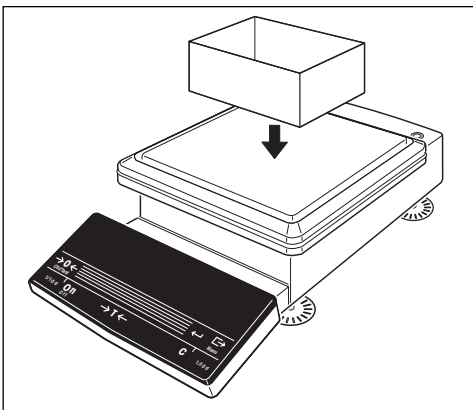

- If you work with a weighing container, place the empty container on the weighing pan.

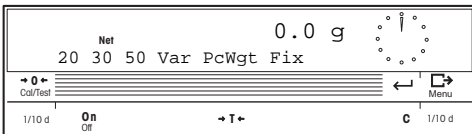
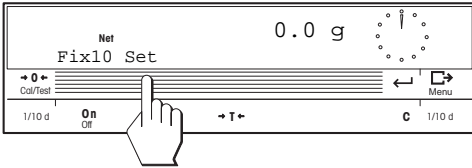
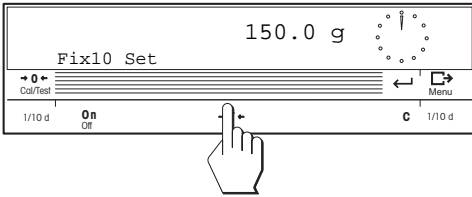

- **Tare** the balance.

- Call up the function for **determination of the reference weight**.

Note: If you are working with a fixed reference piece number of 10 pieces, you can also press the "Fix10" key directly. You will find additional information on this function in section 7.3.

You have the following possibilities available to determine the reference weight:

- fixed piece numbers of 20, 30 and 50 pieces
- a freely selectable piece number
- entry of a piece weight

Reference with fixed piece number

- Add the desired number of parts (20, 30 or 50) to the weighing container.

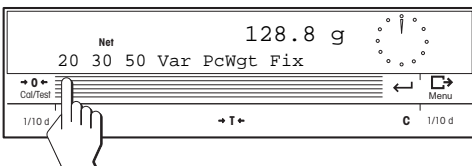
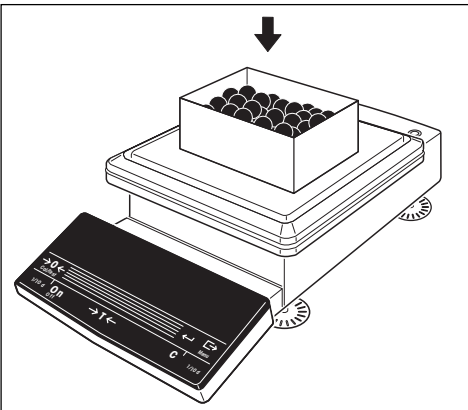

- Initiate the reference determination with the appropriate key ("20" in this example).

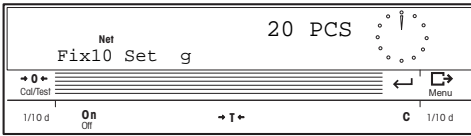

After the reference has been determined, the reference piece number appears in the display.

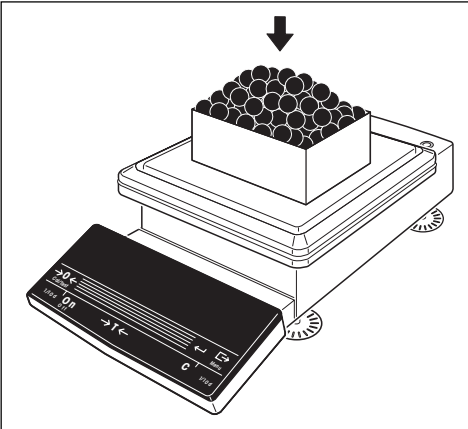

- Now add or remove any number of parts until the target value is reached.

Note: If a second balance is connected as a weighing balance (see also section 7.6), when the reference has been determined, switchover to the second balance takes place automatically.

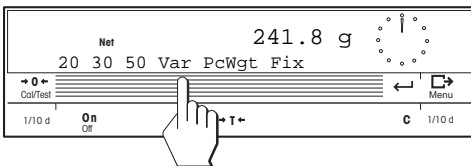

- Add the number of parts you wish to use as the reference piece number to the weighing container and then press the key for a variable piece number.

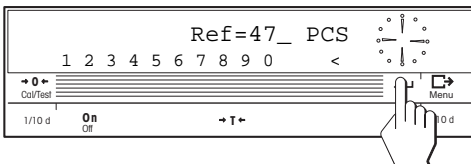

- Enter the number of parts you have loaded and confirm your entry.

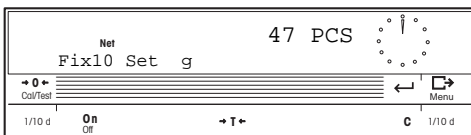

The determined reference piece number ("47" in this example) appears in the display and you can now add or remove any number of parts.

Reference with variable piece number

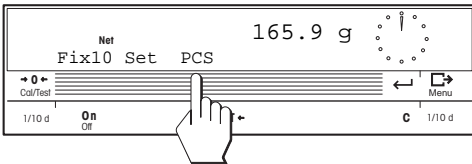
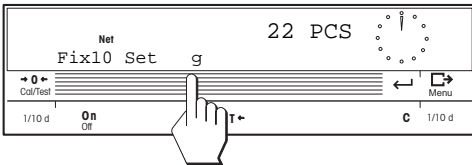
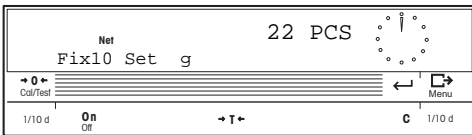
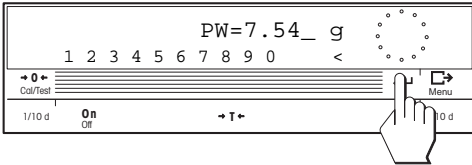
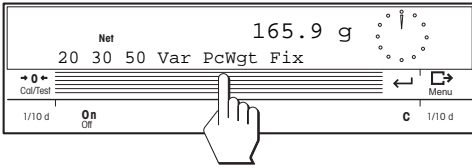

Reference with known piece weight

- Press the key for entry of the piece weight.
- Enter the known piece weight ("7.54 g" in this example) and confirm your entry.

If parts have already been loaded, the piece number determined by the balance appears in the display. You can now add or remove any number of parts.

Switching between piece number and weight display

As soon as a reference has been determined, you can switch between the piece number display and the weight display at any time.

7. Extended counting functions

The extended functions of CountR+ optimize piece counting and support work routines such as "Totalization" and "Portion counting".

7.1 Overview of the extended functions

A total of 9 extended functions are available and these can be activated and deactivated via the menu.

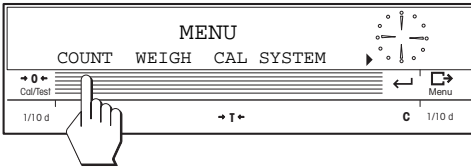

- Select the menu and then choose the main menu "COUNT" to allow activation of the extended functions.

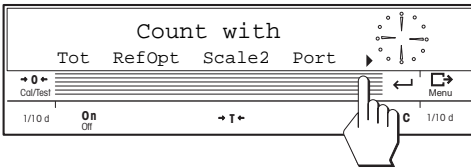

- The following extended functions are available:
- Totalization ("Tot")
 - Reference optimization("RefOpt")
 - Working with a second weighing instrument ("Scale2")
 - Portion counting ("Port")
 - Fixed, user reference piece number ("FixRef")
 - Storing and recalling references ("STO/RCLRef")
 - Add mode ("AddMode"). See also section 5.
 - Serial number for printout ("CNo. ").
 - Transmission of commands to an external application ("External").

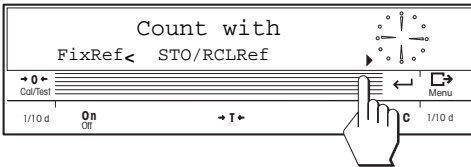

You can activate several extended functions at the same time. In the counting mode, all selected functions appear in the bottom line of the display. For reasons of clarity, the following explanations always assume that only the function being described is activated.

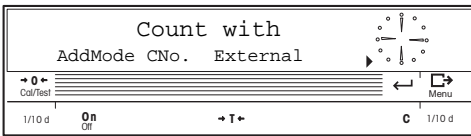

7.2 Reference optimization

This function can be used to optimize an existing reference by the addition of more parts (the more parts used to determine the reference, the greater the accuracy of the reference).

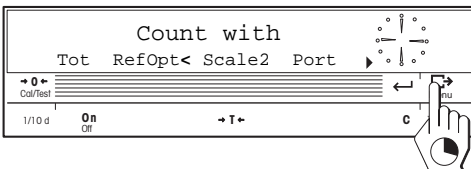

- Activate the "reference optimization" function in the menu. Store your setting and quit the menu.

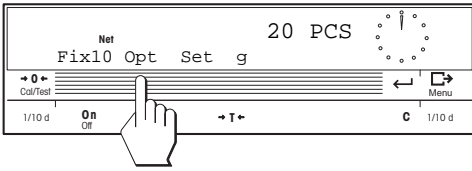

Note

If the loaded piece weight is too large or too small, the display shows "Not allowed". Press the Smart-Bar to exit.

7.3 Fixed, user reference piece number

In simple piece counting, you have the preset, fixed reference piece numbers (20, 30 and 50 pieces) available. If you always work with the same number of reference parts, but this does not correspond to the preset piece numbers, you can select your own fixed reference piece number.

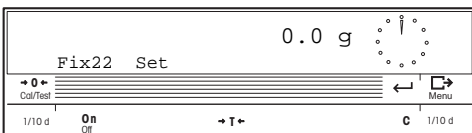
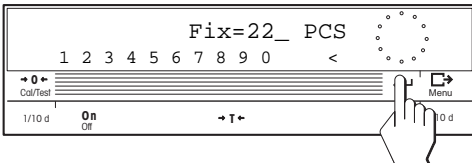
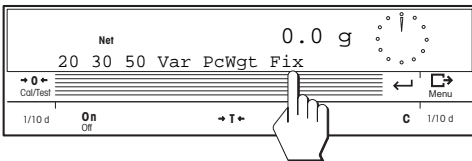
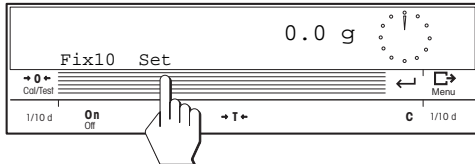
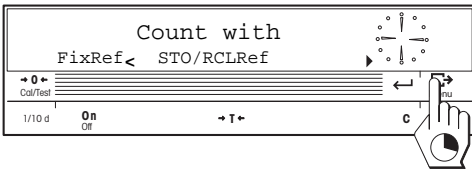

- Determine a reference in the counting mode (section 6). To optimize this reference, load additional parts (**maximum double the number of the stored reference**) and then select the function for reference optimization. The total number of parts is stored as the new reference. You can repeat the optimization of the reference as often as you like.

- Activate the function "fixed, user reference piece number" in the menu (this function is activated in the factory). Activation is necessary only if the function has been switched off). Store your setting and quit the menu.

- In the counting mode, the function "Fix10" (fixed reference with 10 pieces) now appears. To change the fixed reference piece number, press "Set".

- Select the function for entry of the fixed reference piece number.

- Enter the desired fixed reference piece number (e.g. "22") and then confirm your entry.

You now have the selected fixed reference piece number available in the counting mode at a key-stroke.

7.4 Totalization

This function enables you to weigh in different items in succession and to determine the total piece number and the number of items. You also have the possibility to limit the number of items you weigh in.

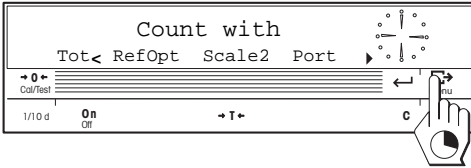

- Activate the function "Totalization" in the menu.

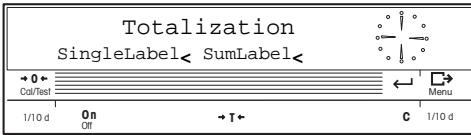

When the function is activated, a submenu appears in which you can make the settings for printing labels. You can choose whether a label should be printed after each lot ("SingleLabel") and/or at the end of the totalization process ("SumLabel"). You will find more information about working with a label printer and the formatting options in section 8.

Store your setting and quit the menu.

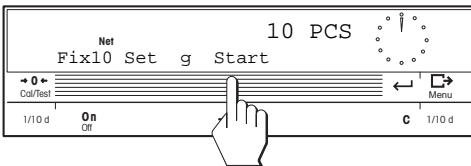

- In the counting mode, determine the desired reference (section 6).

After determination of the reference, "Start" also appears in the display. Select "Start" to move to totalization.

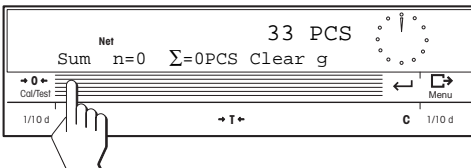
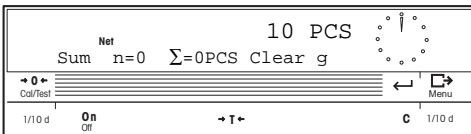

- Weigh in the first item (e.g. 33 pieces) and then press the "Sum" key to store the value in the totalization memory.

Now weigh in the additional items in the same manner.

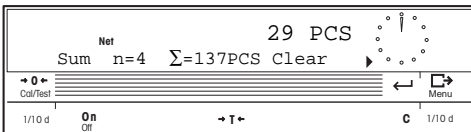

Each time an item has been stored, the item counter "n" is updated and the total (Σ) of all weighed-in parts is displayed.

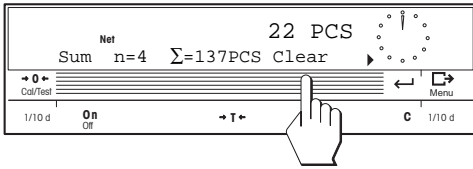

- After you have weighed all items, clear the memory; the reference weight is retained. This clearance is briefly confirmed in the display and you can then start the next totalization operation.

Limiting the number of items

You have the possibility to limit the number of the items you weigh in:

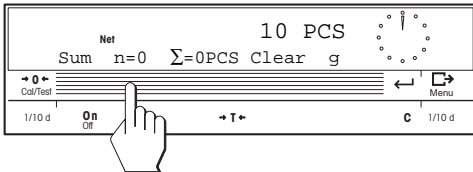

- Press the item counter "n".

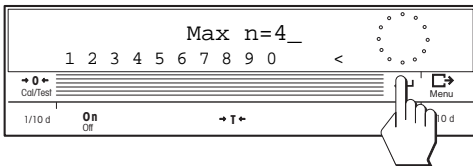

- Enter the maximum number of items admissible per totalization operation (e.g. "4") and then confirm your entry.

As soon as the selected number of items is reached in totalization, the totalization memory is cleared automatically after unloading the balance. The clearance is briefly confirmed in the display and the balance is then ready for the next totalization operation.

7.5 Portion counting

This function enables you to weigh in pieces to a selected target value. You also have the possibility to define an upper and lower tolerance. This application is chiefly used for the packaging of predefined piece numbers. The display can be switched between the number of weighed pieces and the difference to the target value at any time (this "weighing-in to zero" allows precise addition or removal of pieces without a knowledge of the target value).

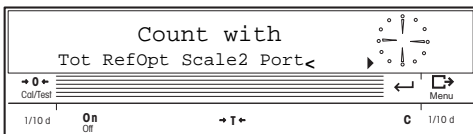

- Activate the function "portion counting" in the menu.

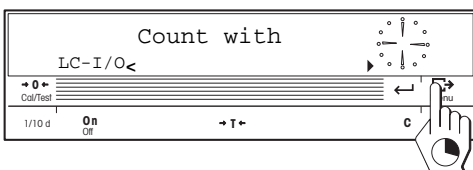

Note: If there is an LC-I/O (programmable relay interface) connected to your balance, you can activate it in the same menu. (You will find more information about how to program the relay interface in the documentation of the LC-I/O).

Store your setting and quit the menu.

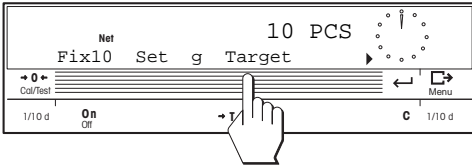

- In the counting mode you must first determine the desired reference (section 6). After determination of the reference, "Target" appears in the display. Select "Target" to proceed further.

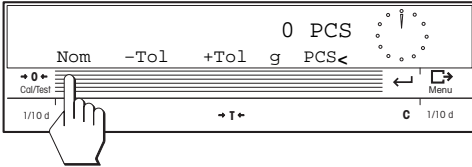

- First decide whether you wish to work with the weight unit ("g") or with pieces ("PCS") in portion counting. Then press "Nom" to enter the target value (nominal value) for the portion counting.

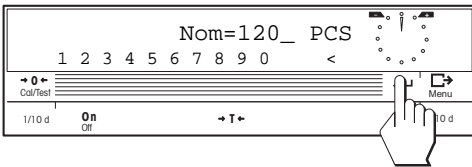

- Enter the target value for portion counting (120 pieces in this example) and confirm your entry.

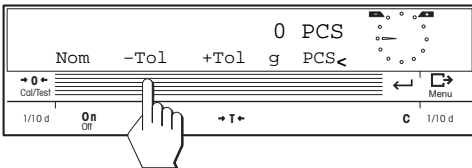

- Select "-Tol" to enter the lower tolerance value for portion counting.

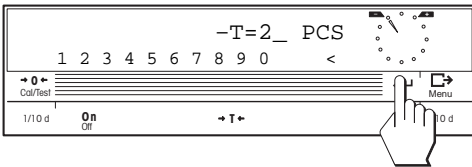

- Enter the lower tolerance value and confirm your entry.

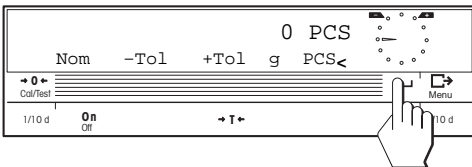

- Enter the upper tolerance value "+Tol" in the same manner and confirm your entry.

- Close the entry of the presettings. The balance is now ready for portion counting.

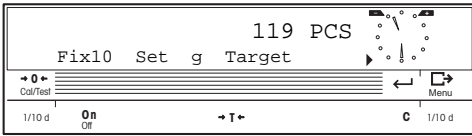

Note: you can always change the target value and the tolerances by pressing the "Target" key.

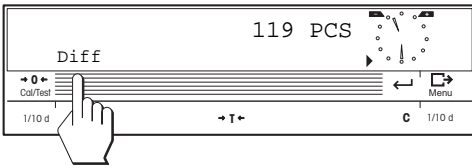

- Now add (or remove) parts until the target weight is reached.

The DeltaTrac with its two tolerance markers supports you during weighing-in. As soon as the coarse indicator has reached the 6 o'clock position, you start the fine weighing-in of pieces until the fine indicator lies between the plus and minus markers (the weighing result is now within the specified tolerances). If the fine indicator points to 12 o'clock, the target piece number has been reached exactly.

- By pressing "Diff", you can always display the difference between the target value and the current value (the asterisk symbol signals that this is a calculated value). You can use this display to weigh in to zero. Press "Abs" to switch back to the absolute display.

7.6 Working with a second weighing instrument

This function enables you to attach a second balance or scale (e.g. PM, AG, Spider, MultiRange, etc.) to your PR/SR balance for determination of the reference and/or for counting.

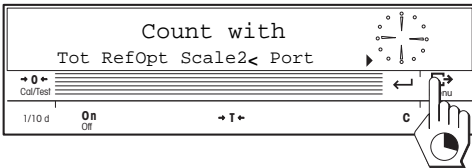

- Activate the function "Scale2" in the menu. Store your setting and quit the menu.

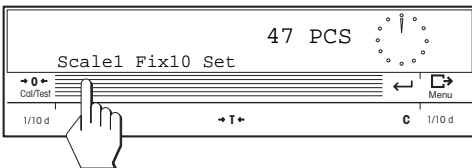

- In the counting mode you can switch between the two weighing instruments at a keystroke. (If a message appears following such a switch stating that no second weighing instrument is available, please check the settings and connections are as described in the diagram on the following page).

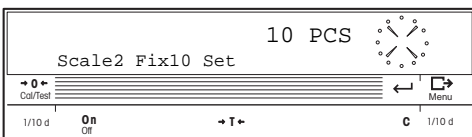

The weighing result of the second balance or scale appears in the display of your PR/SR balance. The moving indicators of the DeltaTrac indicate that these are values from the second instrument. You can use this second balance or scale to determine a reference and/or for counting and also execute all other functions either with weight values of the PR/SR or the second balance or scale.

Attaching a second weighing instrument

The following illustration provides information on how to attach a second weighing instrument. The models shown are representative of all balances and scales listed. Information on the interface boxes to be used incl. settings of the rotary switches and order numbers is also given, as well as details on how to configure the interface of the particular balance or scale.

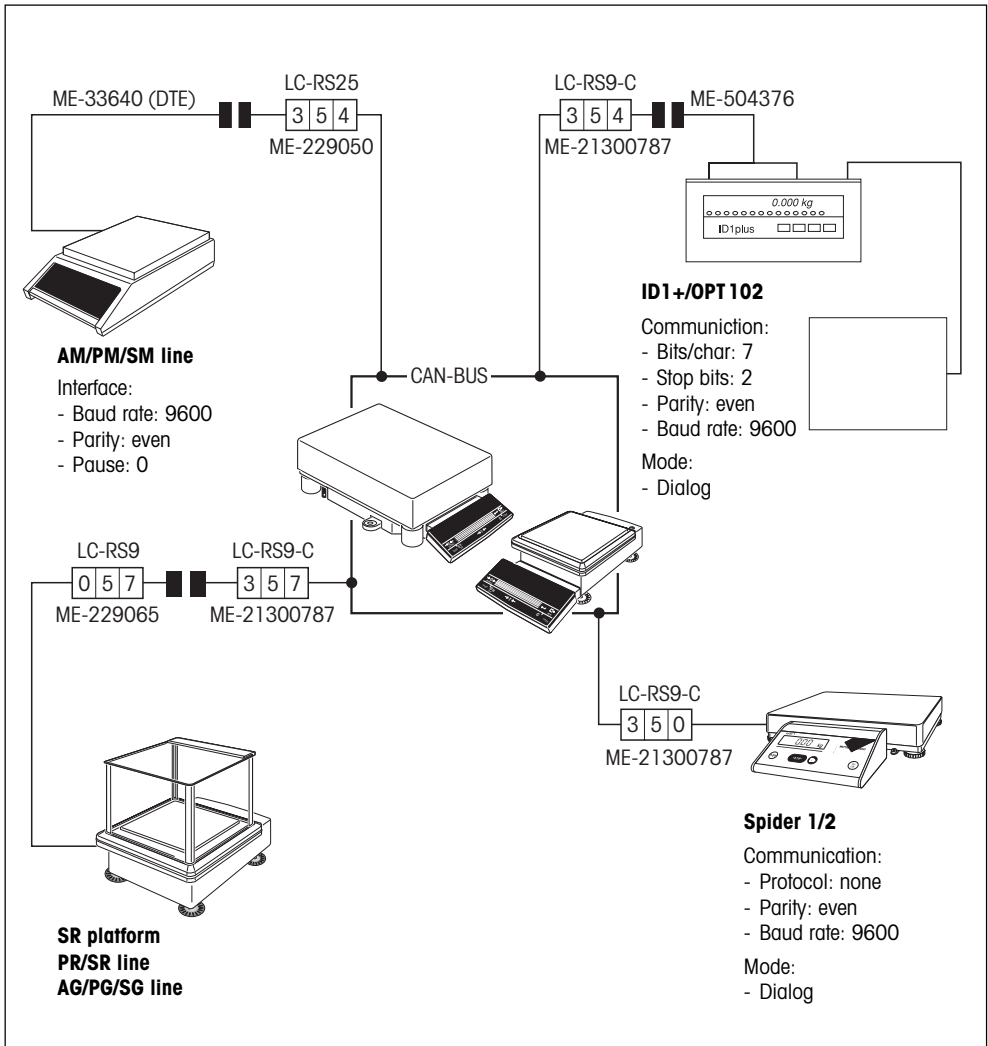

7.7 Storing and recalling references

CountR+ has an integrated database which can store up to 250 references (e.g. for different articles). Each reference comprises a **reference number**, an **article designation**, the **piece weight** and a value for the **preset tare**. As the stored values can be recalled at any time, there is no need to determine a new reference when you change the article. The database is stored in a battery-backed memory; the stored values are thus retained even if the power fails or the balance is disconnected from the power supply. You will find information on how to change the battery in the operating instructions of your PR/SR balance.

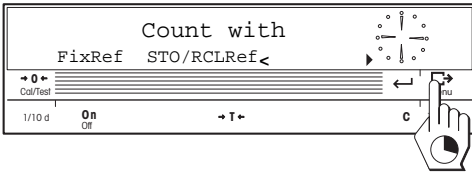

- Activate the function "STO/RCLRef" in the menu. Store your setting and quit the menu.

Entering the reference values

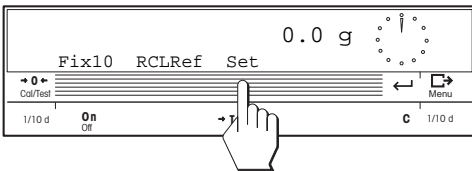

- Before you can use the database, you must enter the reference values. Press "Set".

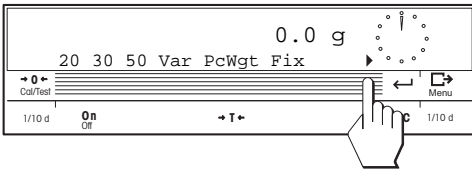

- Switch to the next display.

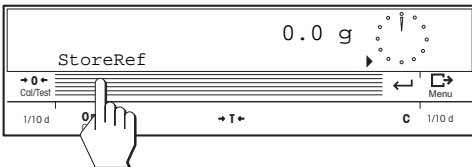

- Select the function for storing the references.

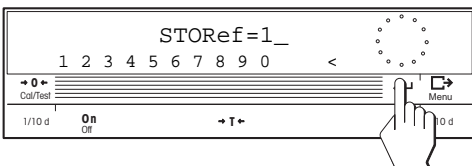

- Select the number under which you wish to store the reference (in the range between 1 and 250) and then confirm your entry.

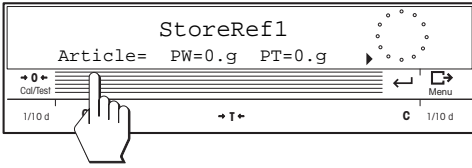

- Press the key for entry of the article designation.

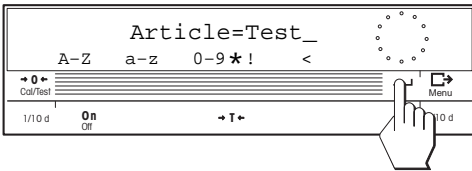

- Enter the article designation ("Test" in the illustration opposite, max. 24 characters) and then confirm your entry.



Note: If you use a bar-code reader, you can also read in a bar code as an article designation directly (e.g. "Test", as in the above example).



- Place the desired number of reference parts on the pan and initiate the function to determine the reference weight.

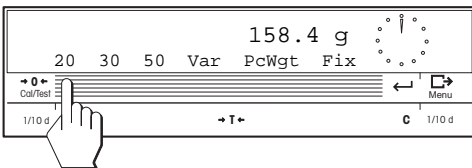

- Select the desired option for determination of the reference weight (see section 6), in the example opposite a fixed number of 20 pieces.

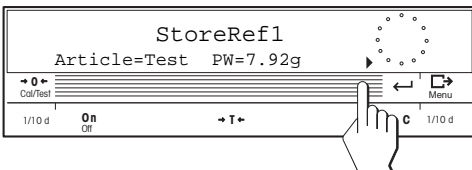

- The calculated average weight per piece appears in the display. If you are working with a weighing container of known weight, you can specify a preset tare in the next display.



- Activate the function for entry of the preset tare (**PT** = manual tare = preset tare).

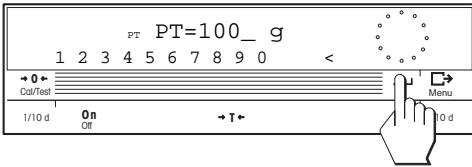

- Enter the weight of the weighing container which should be deducted automatically in every weighing (preset tare) and then confirm your entry.



- The specified preset tare appears in the display. This completes the entry of the reference. If a printer is attached, you can print out your reference if you wish.

If a label printer is connected, only the article name is printed (as a bar code).

- Press the Enter key to return to the function for the storage of references.

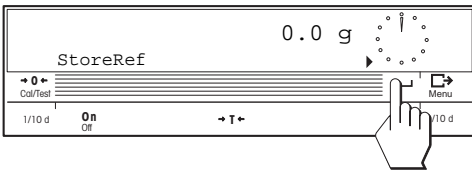

- You can now either enter additional references or return to the counting mode by pressing the Enter key again.

Recalling references

The stored references are retained even if you switch off the balance or disconnect it from the power supply. When in the counting mode, you can recall the stored references at any time.

- Place the weighing container with the parts to be counted on the balance. (If the corresponding reference does not include a preset tare, first place the empty container on the pan and tare the balance with the tare key before you add the parts to the container.)



Note: If you use a bar-code reader, you can read in the code of the article designation when in the counting mode and recall the associated reference directly. In this case, the following steps are unnecessary. If you read in a bar code which is not allocated to a reference, the balance acknowledges read-in of the code with a beep but does not execute the action.

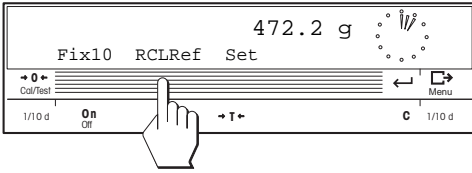

- Activate the function for recall of the references.

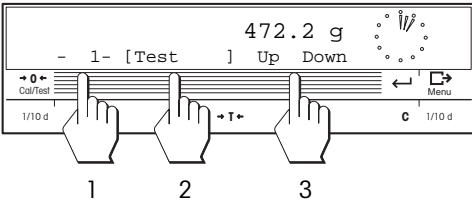

- Select the required reference for the pieces on the pan. The reference can be recalled in 3 different ways:

- 1 By entering the reference number
- 2 By entering the article designation
- 3 By paging through the reference list

Note: Only data fields containing data are displayed.

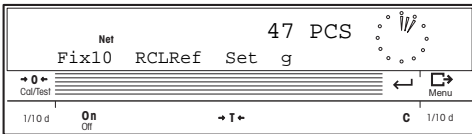

- Confirm the requested reference by pressing "Enter" and the number of pieces will be displayed.

Note: If the order identifications are active (see section 8), after you have selected the reference, you will be requested to input the corresponding identifying information.

7.8 Combining the extended functions

The extended functions described in the previous sections can also be activated simultaneously in any combination. As there is a large number of possible combinations, we will restrict ourselves here to a description of the combination in most frequent use, namely "Totalization and Portion counting".

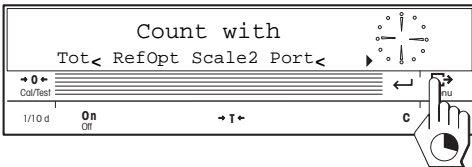

- Activate the two functions "Totalization" and "Portion counting" in the menu. Store your setting and quit the menu.

Note: When the totalization function is activated, a submenu appears where you can make the settings for label printing (see section 7.4).

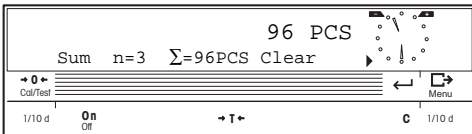
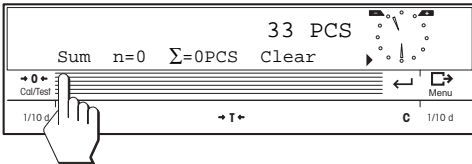
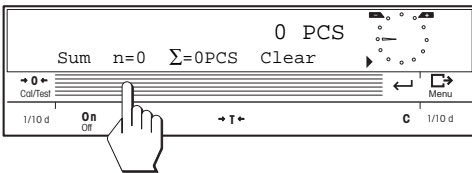
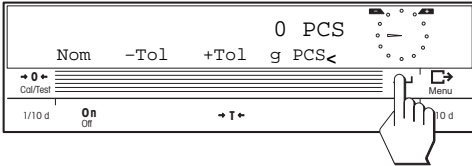
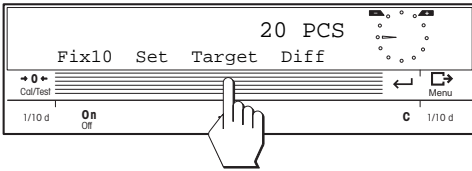

- When in the counting mode, determine the desired reference (section 6). The balance is then ready for portion counting. Press "Target"
- Now specify whether you wish to work with the piece number or the weight display and enter the target value and the tolerances (section 7.5). Then confirm your entries.
- If you wish, you can now limit the number of items which should be weighed (section 7.4).
- Weigh in the first item. The DeltaTrac supports you during weighing-in to the specified target value. Then press the "Sum" key to store the value. You can now weigh in the other items (section 7.4).

Following the storage of each item, the item counter "n" is updated and the total (Σ) of all weighed parts displayed.

Note: If an item lies outside the defined tolerances, an error message appears and the value is not stored.

8. Making printed records of counting operations

In the menu you can specify which data should be printed and activate order identifications which allow the unambiguous identification of each counting operation on the printed records and/or labels. If the order identifications are active, you will be prompted to enter the appropriate data each time you start a new counting operation. You also have the possibility to define free texts which will be printed out in the header of your records and/or labels.

8.1 Activating the order identifications and free texts

Before you can work with the order identifications, you must activate them.

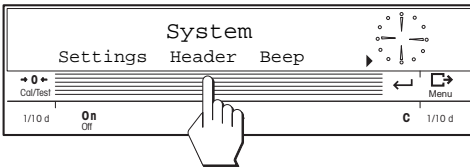

- In the menu "SYSTEM" select the submenu for setting the header options.

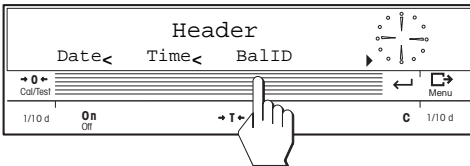

- Activate the options you wish to appear in the header of your records. You have date, time and balance identification available (you will find information on the entry of the date, time and balance identification in the operating instructions of your PR/SR balance).

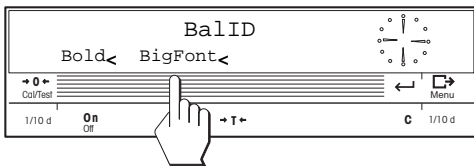

Each time a header option is activated a submenu appears in which you can specify whether the data should be printed bold, and/or with a big font.

Confirm your formatting options.



- Then switch to the next display.

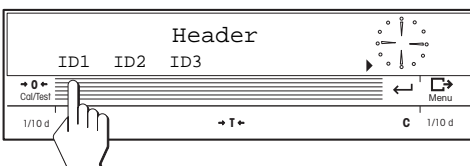

- At this point you can activate the order identification and select the title of the particular identification. Activate the desired identification (e.g. "ID1").

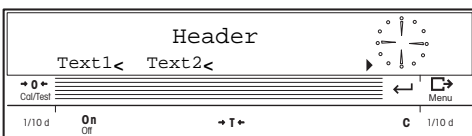
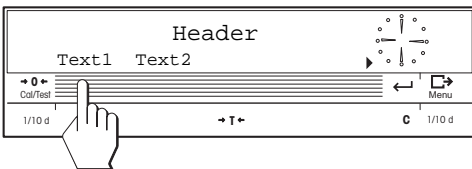
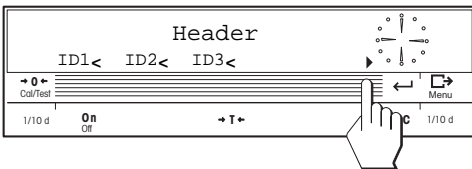
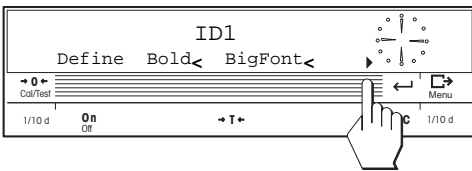
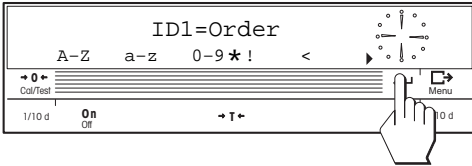
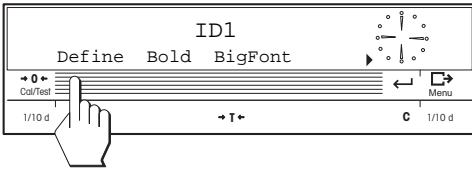

- Select the submenu for defining the title of the selected identification.

- The display shows the title specified for ID1. You can leave the title unchanged or enter your own title of length maximum 24 characters (e.g. "Customer", if you wish to use ID1 to name the customer). Then confirm your entry.

- Select the required formatting for ID1. The following options are available: bold, big font, and bar code. Confirm your settings. **Note:** The height of the bar code can be increased by simultaneously selecting big font and/or bold.

- If required, activate the additional identifications (ID2 and ID3) and change their titles if you are not satisfied with the preselected texts (the preselected titles propose using ID2 for the article designation and ID3 to indicate the lot). The same formatting options as for ID1 are also available. Then switch to the next display.

- At this point you can activate the free texts you wish to appear in the header of each record and define their content. Activate the desired text (e.g. "Text1").

- A submenu appears similar to the one for the order identifications (ID1 to ID3) in which you can specify the text and formatting. Then confirm your entry.

- If required, activate the second free text and enter the desired text (e.g. the department or the address of your company).

8.2 Working with order identifications

In the following description we assume that you have activated all identifications and the two free texts. The following example is based on a simple piece counting (section 6), but the identifications are naturally also available for all extended functions.

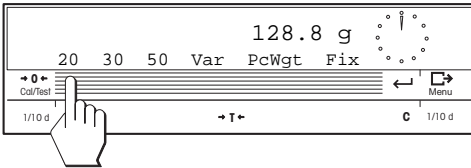

- Determine the reference weight (e.g. 20 pieces).

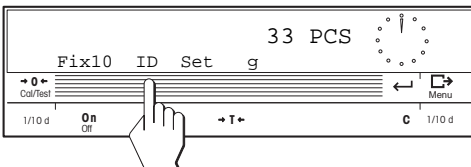

- If you choose "ID", the title you have defined for ID1 appears and you are prompted to enter the text. Enter the text (e.g. the order number, max. 24 characters) and store the entry.

Note: If you use a bar-code reader, you can also read in a bar code directly. This also applies to the following entries.

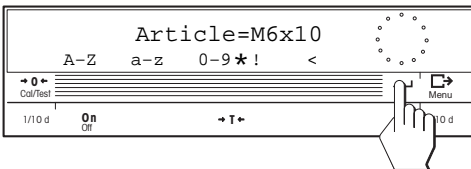
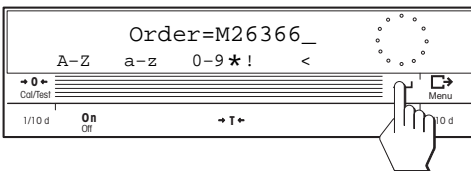

- The title you have defined for ID2 then appears and you are prompted to enter the text. Enter the text (e.g. the article designation, max. 24 characters) and store the entry.

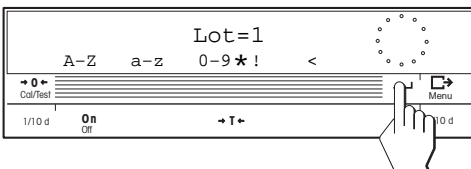

- The title you have defined for ID3 then appears and you are prompted to enter the text. Enter the text (e.g. the lot number, max. 24 characters) and store the entry.

- Now start your piece counting operations. You can use the Print key to print out a record of the piece counting at any time. In portion counting, the display for the entry for ID3 appears each time an item is weighed in.

Free text1	Mettler Toledo GmbH
Free text2	Service Dept.
Date/time	16.03.99 16:39:22
	PW: 7.92 g
	out of 12 PCS
Consecutive number	CNo.: 4711
	T 50.00 g
	G 428.08 g
	N 388.08 g
	240 PCS
Title ID1	Order: M26366
Title ID2	Article: M6x10
Title ID3	Lot: 1
	----- END -----

The printout opposite (generated by pressing the Print key) is a specimen illustrating the above example and the settings you have made in the menu (see section 8.1):

- The first and second lines of the record show the entries you have defined for the two free texts.
- The third line records the date and time, the fourth and following line the piece weight and "out of".
- The sixth line contains a serial number for unambiguous traceability of an order (see section 8.3).
- The lines following the titles, which have been defined in the menu for the three order identifications, show the texts you have entered during the counting operation.

8.3 Activating the consecutive serial number

To make processing of the order traceable a consecutive number can be printed on every printout (see printout above).

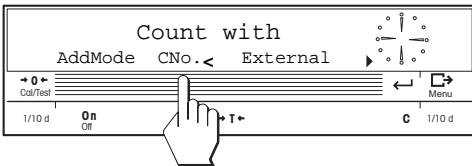

- If you wish to have a consecutive number on each printout, activate the option "CNo." in the "COUNT" menu. Save the setting after you have made it.

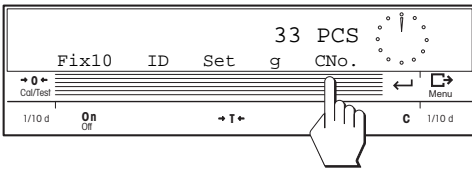

- In piece counting mode you can specify the number at which the consecutive numbering should start. To do this press "CNo."

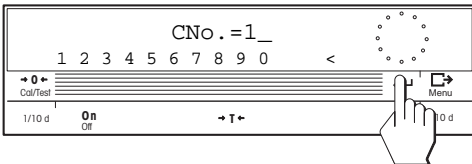

- Enter the number at which you wish consecutive numbering to start and confirm your setting. With each printout the number will be increased by 1. **Note:** By pressing "CNo." you can call up the current number and change it if required.

8.4 Selecting the data for the printed record

You can select the data to be printed on your reports and labels and specify how it should be formatted.

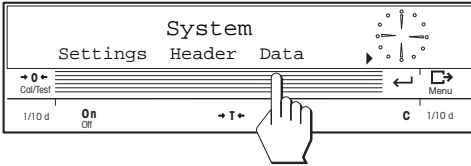

- In the "SYSTEM" menu select the submenu to specify the data to be included in the report.

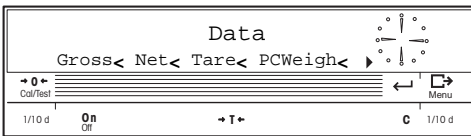

- Activate the data to be included in the reports and/or labels. The following data items are available:

- Gross weight ("Gross")
- Net weight ("Net")
- Tare ("Tare")
- Reference item weight ("PCWeigh")
- Reference piece count ("out_of")
- Number of pieces ("PCS")
- Total to be accumulated ("Total")
- Plus/minus tolerance for portioning (" +/-Tol").

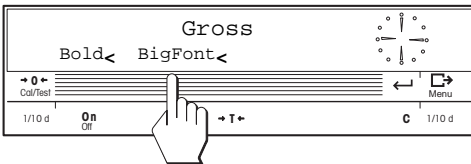
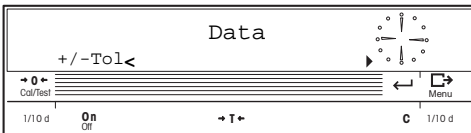
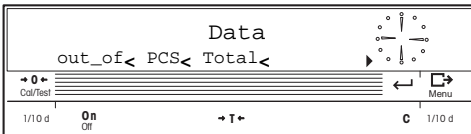

Each time an option is activated a submenu appears in which you can specify how the data is to be formatted (refer to the two examples shown at left). You can choose whether the data should be printed **bold**, and/or with a **big font**. For tare, reference item weight, number of pieces, and the total, an option can also be selected (on the label printer only) to print them out as **bar codes**. All the available formatting options can be combined.

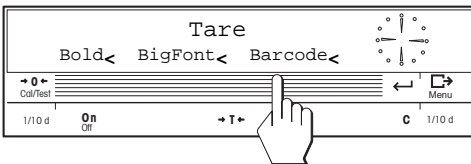

- Save your settings.

8.5 Settings for the label printer

If your balance is connected to a label printer, you can provide the weighed orders and lots with labels. For selection and connection of a suitable printer, please contact your METTLER TOLEDO dealer. The following data are printed out, provided they have been activated in the menu:

- Date, time, and balance identification
- Order identifications and free texts (see sections 8.1 and 8.2)
- Consecutive sequence number (see section 8.3)
- The data selected for printing out (see section 8.4)

To print labels a number of special settings are required:

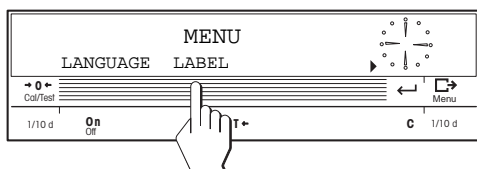

- Select the menu for the label printer.

Note: All the settings in this menu relate only to the label printer and have no effect on any data printer that may also be connected.

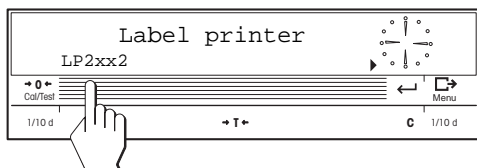

- Activate the label printer (currently the Eltron LP2xx2 range is supported). When the printer is activated, a submenu for selecting the bar code type appears.

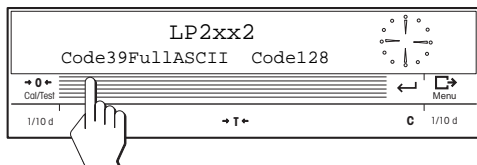

- Select the bar code type required:
 - Extended Code 39 (complete ASCII character set).
 - Code 128

Note: Code 39 uses 2 characters each to make up small letters and figures. Because of this, the length of the code depends on the lettering used, which can cause problems on small labels. For this reason, we recommend working with capital letters only.

Confirm the setting you have selected.



In the menu for the label printer you will find two further settings:

- A fixed format for unformatted output of the label data on a matrix printer
- An option for switching off the matrix printer.

We recommend you to print out several sample labels and to keep changing the data selected for printing, and how it is formatted, until the printout fits into the space on your specific label and meets your wishes.

9. Transmitting commands to an external instrument

CountR+ supports transmission of commands to an external instrument. For example, you can use this feature to call up references from a database on a PC and use them to extend the internal database of 250 references without restriction.

Defining the commands

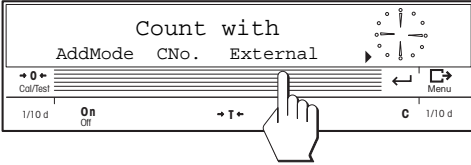

- Before you can use external commands, you must define them in the menu. In the "COUNT" menu select the option for external commands.

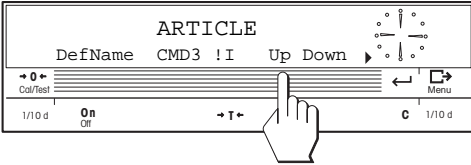

- When the option is activated, a submenu for defining the commands appears. You can define up to 8 commands. **Note:** The first command (CMD !I) is defined at the factory for calling up an article from the optional PC backup/restore software. We recommend you not to change this command. Instead, select the second command.

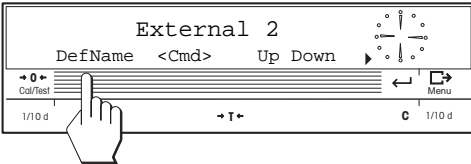

- Call up the option to define the **name of the command**.

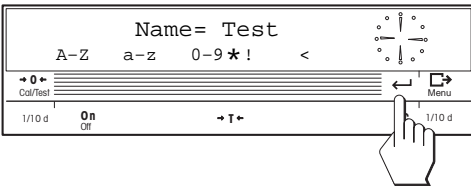

- Define the name of the command. Since the name will subsequently be displayed in piece counting mode, define a name which describes the corresponding command as clearly as possible (max. 24 characters). Confirm the name you have input (in the example shown here, "Test").

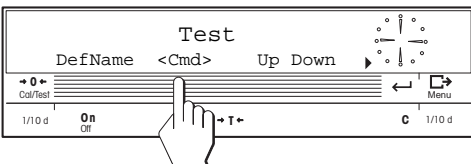

- Call up the option for **defining the command**.

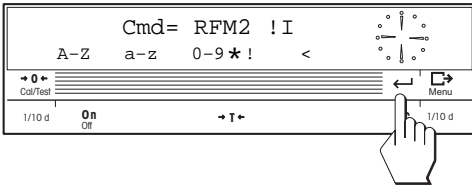

- Enter the command. Since this must, of course, be one which is understood by the specific receiving instrument or software, details cannot be given here. The example assumes that the command is "RFM2". **Note:** The character string "!I" is optional and has the following function: When the command is sent, a dialog box appears into which a number can be entered to be transmitted with the command (e.g. to call up a specific article).

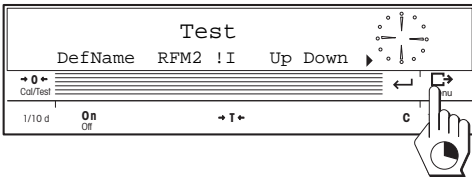

- Definition of the command is now complete. Save the commands you have defined and return to piece counting mode.

Sending the commands



- After the commands have been defined in the menu and activated, in piece counting mode the option for external commands appears at the left in the display. **Note:** If only one command has been defined, its name appears directly in the display.

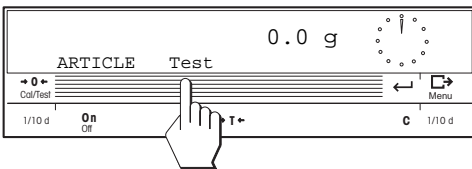

- When the option for external commands is activated, the defined commands appear for selection. Select the command required and it will then be transmitted directly to the external instrument.

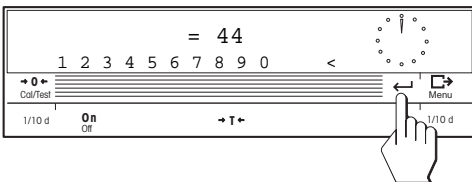

- If the selected command contains the character string "!I", a dialog window appears before the commands are transmitted. The number to be transmitted together with the command (e.g. "44") should be entered in this window. Confirm your input and the command will be transmitted to the external instrument (in this example, the command "RFM2_44").

10. Printing out the balance settings

We advise you to print out the balance settings each time you make a change in the menu and to store the printout in a safe place. You thus have the possibility to restore all settings should they be lost (e.g. if the back-up battery of the cassette is exhausted).

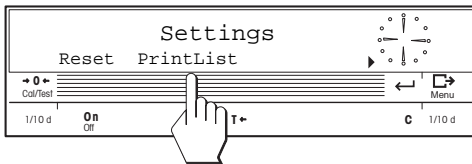

- In the menu "SYSTEM" select the submenu "Settings" and activate the function for printing out the balance settings.

```

--- LIST OF SETTINGS ---
16.03.99      14:12:33
CountR+
Type:                S32001
SNR:                2114004711
Bal:                Waage 1
SW : 2.50 1.10 26233112
Terminal:          2.10 R
-----
Count with          Tot
-----
Weighing
Vibrations          Medium
WghProcess          Normal
ReproSet            Good
Unit1                g
Unit2                kg
CustomUnit          Off
AutoZero            On
PreTare             Off
-----
Calibration        ManIntern
Test                Internal
-----
System
Header              Date
                    Time
                    BalID
                    ID1
                    ID2
                    ID3

Text1=
Mettler-Toledo GmbH
Text2=
Service Dept.
Beep                On
Icons               AutoOff
StartUp             Full
-----
Language            English
----- END -----

```

The printout opposite shows a **specimen record**. Your individual record may differ from this specimen, depending on the type of balance you have and the settings you have selected.

Notes:

- If you have activated the function "Storing and recalling references", all references entered in the database will also be recorded. The article designation, the piece weight and the preset tare will be printed for each reference. Should you lose your data, you can quickly reconstruct them using the records.
- The data items selected to printed out on the counting reports and labels (see section 8.4) are also printed on the report of the balance settings, but they are not shown in the example at left due to insufficient space.

11. Appendix

11.1 Optional equipment and system overview

You can order the following **optional equipment** from your METTLER TOLEDO dealer: LC-P43 Printer and LC-RS9/LC-RS25 Interface Boxes. Other special optional equipment is available on request. The following illustration provides a schematic overview of the most important **peripheral units** which can be attached to your PR/SR balance (with CountR+ application).

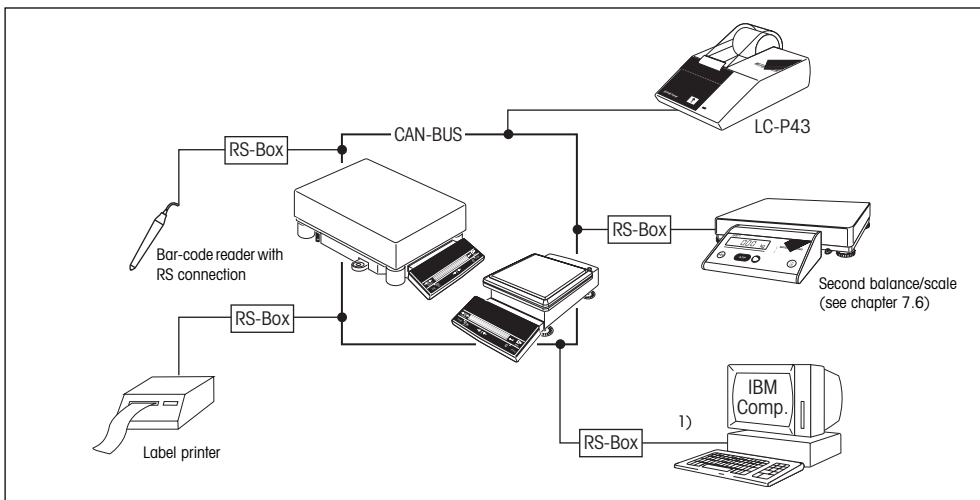

1) CountR+ Backup/Restore for backup of the stored data (optional)

For the attachment of peripheral units which have no LocalCAN connection, interface boxes are necessary whose configuration depends on the device in question. The following table shows the settings of the rotary switches of the boxes for the individual devices.

Peripheral unit	Setting of rotary switches		
	Switch 1 (device type)	Switch 2 (baud rate)	Switch 3 (protocol)
Bar-code reader with RS port	4 ⁵⁾	5 ²⁾	7 ²⁾
Host (PC)	0	5 ²⁾	7 ²⁾
Label printer	4 ⁴⁾	5 ²⁾	7 ³⁾

2) Example of setting; the effective value to be selected depends on the data transmission rate and the protocol supported by or stipulated for the particular peripheral unit.

3) Recommended setting (ASCII character set English), other settings possible.

4) To prevent conflicts with bar-code reader, open Rx/D.

5) Requires power supply via RS connection, contact your METTLER TOLEDO dealer for more information.

11.2 SICS commands

If your balance is connected to a PC, you can transfer commands to CountR+ and request settings. CountR+ supports the command set **MT-SICS** (**M**ETTLE**R** **T**O**L**E**D**O - **S**tandard **I**nterface **C**ommand **S**et). This command set has been supplemented by the following specific commands for CountR+:

Request and set piece weight

Command	Action	Response
PW	Request piece weight	PW_A_ 1.2345 g
PW_ 1.2345 g	Set piece weight	PW_A

Request and set order identification 1 (ID1)

Command	Action	Response
I12	Request ID1	I12_A_ "Order"
I12_ "Customer"	Set ID1	I12_A

Request and set order identification 2 (ID2)

Command	Action	Response
I13	Request ID2	I13_A_ "Article"
I13_ "Part No."	Set ID2	I13_A

Request and set order identification 3 (ID3)

Command	Action	Response
I14	Request ID3	I14_A_ "Lot"
I14_ "Manufact. No."	Set ID3	I14_A

Request and set free text 1 (Text 1)

Command	Action	Response
I15	Request Text1	I15_A_ "[Text1]"
I15_ "Mettler-Toledo"	Set Text1 (max. 24 characters)	I15_A

Request and set free text 2 (Text 2)

Command	Action	Response
I16	Request Text2	I16_A_ "[Text2]"
I16_ "Service Dept."	Set Text2 (max. 24 characters)	I16_A

**To protect your METTLER TOLEDO product's future:
METTLER TOLEDO Service assures the quality, measuring
accuracy and preservation of value of all METTLER TOLEDO
products for years to come.
Please send for details about our attractive terms of service.
Thank you.**



Subject to technical changes and to the availability of the accessories supplied.

Printed on recycled paper.
Because we care.

© Mettler-Toledo GmbH 1999 21201116C Printed in Switzerland 9905/2.12

Mettler-Toledo GmbH, CH-8606 Greifensee, Switzerland, Tel. (01) 944 22 11, Fax (01) 944 30 60, Internet: <http://www.mt.com>

AT Mettler-Toledo Ges.m.b.H., A-1100 Wien, Tel. (01) 604 19 80, Fax (01) 604 28 80
AU Mettler-Toledo Ltd., Port Melbourne, Victoria 3207, Tel. (03) 9646 4551, Fax (03) 9645 3935
BE n.v. Mettler-Toledo s.a., B-1651 Lot, Tél. (02) 334 02 11, Fax (02) 378 16 65
BR Mettler-Toledo Indústria e Comércio Ltda., São Paulo, CEP 06465-130, Tel. (11) 421 5737, Fax (11) 725 1962
CA Mettler-Toledo Inc., Ontario L7R3Y8, Tel. (905) 681 7011, Fax (905) 681 1481
CH Mettler-Toledo (Schweiz) AG, CH-8606 Greifensee, Tel. (01) 944 45 45, Fax (01) 944 45 10
CN Mettler-Toledo Instr. (Shanghai) Ltd., Shanghai 200233, Tel. (21) 6485 0435, Fax (21) 6485 3351
CZ Mettler-Toledo, spol. s.r.o., CZ-12000 Praha 2, Tel. (2) 251 555, Fax (2) 242 47 583
DE Mettler-Toledo GmbH, D-35353 Giessen, Tel. (0641) 50 70, Fax (0641) 52 951
DK Mettler-Toledo A/S, DK-2600 Glostrup, Tel. (43) 27 08 00, Fax (43) 27 08 28
ES Mettler-Toledo S.A.E., E-08038 Barcelona, Tel. (03) 223 22 22, Fax (03) 223 02 71
FR Mettler-Toledo s.a., F-78222 Viroflay, Tél. (01) 309 717 17, Fax (01) 309 716 16
HK Mettler-Toledo (HK) Ltd., Kowloon HK, Tel. (852) 2744 1221, Fax (852) 2744 6878
HR Mettler-Toledo, d.o.o., CR-10010 Zagreb, Tel. (1) 660 2189, Fax (1) 660 3009
HU Mettler-Toledo Kft, H-1173 Budapest, Tel. (1) 257 9889, Fax (1) 257 7030
IT Mettler-Toledo S.p.A., I-20026 Novate Milanese, Tel. (02) 333 321, Fax (02) 356 29 73
JP Mettler-Toledo K.K., Shiromi, J-Osaka 540, Tel. (6) 949 5901, Fax (6) 949 5945
KR Mettler-Toledo (Korea) Ltd., Seoul (135-090), Tel. (02) 518 20 04, Fax (02) 518 08 13
MY Mettler-Toledo (M) Sdn.Bhd., 47301 Petaling Jaya, Tel. (03) 703 2773, Fax (03) 703 8773
MX Mettler-Toledo S.A. de C.V., Mexico CP 06430, Tel. (5) 547 5700, Fax (5) 541 2228
NL Mettler-Toledo B.V., NL-4000 HA Tiel, Tel. (0344) 638 363, Fax (0344) 638 390
NO Mettler-Toledo A/S, N-1008 Oslo, Tel. (22) 30 44 90, Fax (22) 32 70 02
PL Mettler-Toledo, Sp. z o.o., PL-02-929 Warszawa, Tel. (22) 651 92 32, Fax (22) 42 20 01
RU Mettler-Toledo AG, 10 1000 Moskau, Tel. (095) 921 68 12, Fax (095) 921 63 53
SE Mettler-Toledo AB, S-12008 Stockholm, Tel. (08) 702 50 00, Fax (08) 642 45 62
SG Mettler-Toledo (S) Pte. Ltd., Singapore 139944, Tel. (65) 778 6779, Fax (65) 778 6639
SK Mettler-Toledo service, s.r.o., SK-83103 Bratislava, Tel. (7) 525 2170, Fax (7) 525 2173
SL Mettler-Toledo, d.o.o., SL-61111 Ljubljana, Tel. (6) 112 35 764, Fax (6) 127 4575
TH Mettler-Toledo (Thailand), Bangkok 10310, Tel. (02) 719 64 80, Fax (02) 719 64 79
TW Mettler-Toledo Pac Rim AG, Taipei, Tel. (62) 579 59 55, Fax (62) 579 59 77
UK Mettler-Toledo Ltd., Leicester, LE4 1AW, Tel. (0116) 235 0888, Fax (0116) 236 5500
US Mettler-Toledo, Inc., Worthington, Ohio 43085, Tel. (614) 438 4511, Fax (614) 438 4755

For all other countries: **Mettler-Toledo GmbH**, PO Box VI-400, CH-8606 Greifensee, Tel. (01) 944 22 11, Fax (01) 944 31 70