

SAG weighing modules

METTLER TOLEDO

The simple solution for unusual weighing tasks

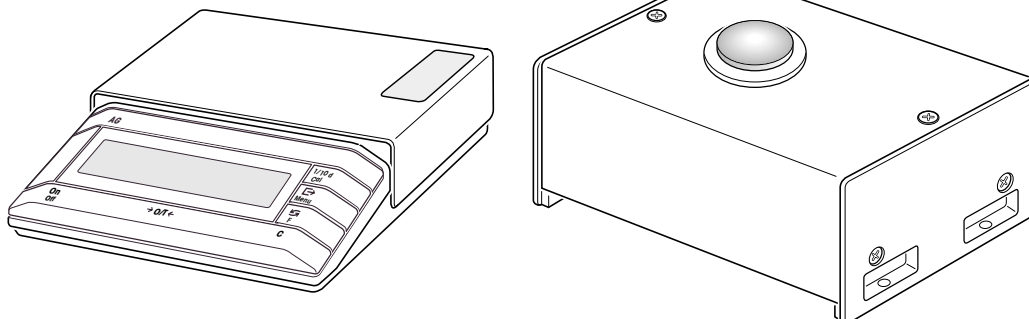

Rapid weight control of target weights from 0.1 g to 210 g

You are filling powders or liquids. You produce small parts from plastic. You make tablets and capsules. You want to sort your products by weight. You control operations today with random sample checks.

You want to have full control over quality and limit material losses and rejects to a minimum.

Weighing under special conditions

You want to integrate a 5-, 3- or 4-decimal place balance in a robot system. You are looking for a compact weighing unit with a separate display. You are weighing in a contaminated environment. You want to perform weight determinations in a confined space or at low air pressure.

The weighing modules SAG285, SAG204 and SAG203F from METTLER TOLEDO provide a simple solution for these and for many other weighing tasks.

The weighing modules were developed for use in production machinery, for highly accurate weighing under difficult circumstances and conditions, as well as for accurate weight determination in procedures where timing is critical.

System description

The products SAG285, SAG204 and SAG203F consist of two parts:

- Compact, sealed weighing cell, which can be fixed to a flat base
- Electronic control unit with operating terminal, display and data interface

The weighing cell can be calibrated at any time by the press of a knob or via the data interface using the integrated calibration weight. With the SAG285 und SAG204 a completely automatic calibration without intervention by the user is also possible.

While the SAG285 resp. SAG204 has the readability of a classical analytical balance of 0.01 mg resp. 0.1 mg, the SAG203F with reduced readability of 0.001 g offers an appreciably shorter stabilization time of just one second. It can therefore be used, in situations where high throughput is important.

The typical areas of application are:

- "one shot" dispensing systems (preset amount is filled in one dose)
- Sorting or "on-line" weight control of small items (tablets, plastic moldings etc.)
- Robot controlled or automated determination of weight
- Weighing in confined fume hoods or fume chambers
- Weighing in a contaminated environment (poisons)
- Weighing under special pressure conditions, e.g. under vacuum



Dimensions

all dimensions in mm

Electronic control unit

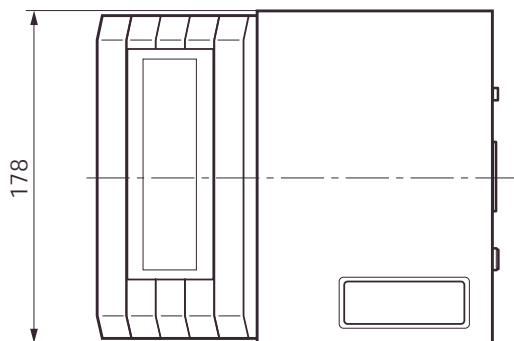
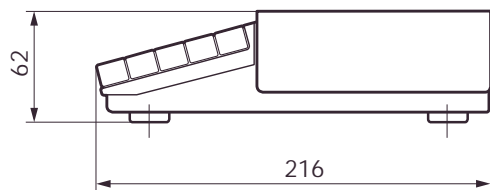

Weighing cell

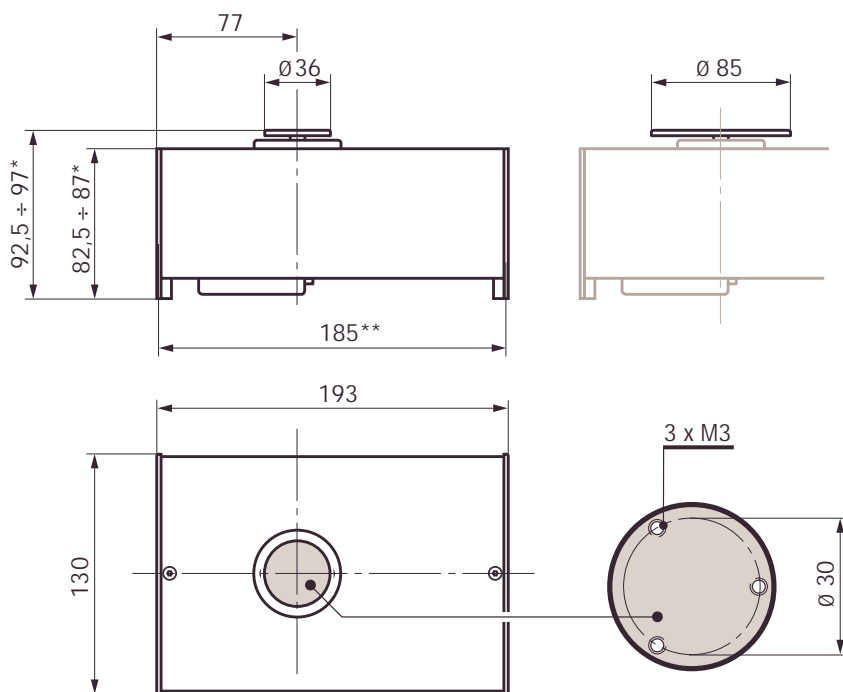

Mounting options

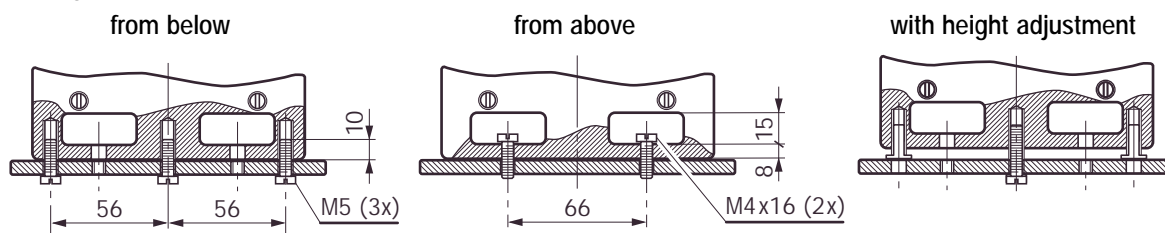

* Height adjustable

** Distance between the attachment points

Technical data for weighing modules SAG285, SAG204, SAG203F

For operation refer to "Operating instructions METTLER TOLEDO AG balances"

	SAG285	SAG204	SAG203F
Readability	0.01 mg ⁶⁾ /0.01 mg ⁶⁾ /0.1 mg	0.1 mg	0.001 g
Max. weighing capacity	41 g ⁶⁾ /81 g ⁶⁾ /210 g	210 g	210 g
Taring range	0...81 g ⁶⁾ /0...210 g	0...210 g	0...210 g
Repeatability	0.02 mg ⁶⁾ /0.05 mg ⁶⁾ /0.1 mg	0.1 mg	0.5 mg
Linearity ¹⁾	± 0.03 mg ⁶⁾ /± 0.1 mg ⁶⁾ /± 0.2 mg	± 0.2 mg	± 0.001 g
Sensitivity drift ¹⁾	2 ppm/°C	2 ppm/°C	2 ppm/°C
Stabilization time (typical)			
0...30 g	≥ 6 s ⁶⁾	≥ 3 s	1.0 s
30...210 g	≥ 3 s	≥ 3 s	1.2 s
Calibration weight, internal	200 g	200 g	200 g
Calibration weight, external	40/100/200 g	50/100/200 g	–
Calibration, internal/manual,	full automatic (FACT) or via control command		manual or via control command
Weighing unit 1	g, oz, ozt, GN, dwt, ct, mg, mo, msg		g, kg, lb, oz, ozt, GN, dwt, ct, mg, mo, msg
Weighing unit 2	mg, mo, msg, H tl, S tl, T tl, g, oz, ozt, GN, dwt, ct		–
Application functions	Piece counting, percent weighing, formulation, dynamic weighing		–
Data interface (with the electronic unit)	LocalCAN, RS232 ²⁾		LocalCAN, RS232 ²⁾
Control commands ³⁾	MT-SICS (as with AG balances)		MT-SICS Level 0 + 1 (V 2.10 or higher); Level 2: C3 (Calibration); M (Menu) Level 3: MS (Unit); SS (Send 2 weight values)
Display (with the electronic unit)	LCD (passiv)		
Weighing pan	Ø 85 mm (weight = 68 g), stainless steel and Ø 36 mm (weight ~ 10 g) (Order No. 238839), aluminium, non-rotatable		
Admissible dead load, weighing pan incl.	65 - 71 g		
Net weight:			
– electronic unit with power adapter	2.1 kg		
– weighing cell	2.9 kg		
Total weight	6.8 kg		
Cable length between electronic unit/cell ⁴⁾	1.5 m (Sub.D 25pin at both sides)		
Fuse	Temperature switch		
Power supply with AC/AC adapter	115 V - 20 % + 15 %, 50/60 Hz, 195 mA, sec. 12 V, 50/60 Hz, 1.25 A		
and country specific cable	230 V - 20 % + 15 %, 50/60 Hz, 90 mA, sec. 12 V, 50/60 Hz, 1.25 A		
Power supply direct	9.5 - 17.5 V, 50/60 Hz, 7 VA or 9 - 20 V=, 7 W		
(without adapter)			
Admissible ambient conditions	Use only in closed rooms, installation category II, pollution degree 2		
Admissible ambient temperature ⁵⁾	5 - 40°C		
Max. relative atmospheric humidity	80 % RH by 30°C		
Height up to above sea level	4000 m		

¹⁾ Within the temperature range 10 - 30 °C

²⁾ RS232-C with sep. cable LC-RS9 resp. LC-RS25

³⁾ Control commands according to "Reference Manual MT-SICS" (delivered with LC-RS cable)

⁴⁾ Different lengths on request (max. 10 m)

⁵⁾ Temperature changes may not lead to the formation of water of condensation in the weighing cell or electronic unit.

⁶⁾ Values in fine range

Technical data for weighing module SAG245

For operation refer to "Operating instructions METTLER TOLEDO AG balances"

	SAG245**
Readability	0.01 mg ⁶⁾ /0.1 mg
Max. weighing capacity	41 g ⁶⁾ /210 g
Taring range	0...41 g ⁶⁾ /0...210 g
Repeatability	0.02 mg ⁶⁾ /0.1 mg
Linearity ¹⁾	± 0.03 mg ⁶⁾ /± 0.2 mg
Sensitivity drift ¹⁾	2 ppm/°C
Stabilization time (typical)	
0...30 g	≥ 6 s ⁶⁾
30...210 g	≥ 3 s
Calibration weight, internal	200 g
Calibration weight, external	40/100/200 g
Calibration, internal/manual, Weighing unit 1 Weighing unit 2 Application functions	full automatic (FACT) or via control command g, oz, ozt, GN, dwt, ct, mg, mo, msg mg, mo, msg, H tl, S tl, T tl, g, oz, ozt, GN, dwt, ct Piece counting, percent weighing, formulation, dynamic weighing
Data interface (with the electronic unit) Control commands ³⁾	LocalCAN, RS232 ²⁾ MT-SICS (as with AG balances)
Display (with the electronic unit) Weighing pan Admissible dead load, weighing pan incl.	LCD (passiv) Ø 85 mm (weight = 68 g), stainless steel and Ø 36 mm (weight ~ 10 g) (Order No. 238839), aluminium, non-rotatable 65 - 71 g
Net weight: – electronic unit with power adapter – weighing cell Total weight	2.1 kg 2.9 kg 6.8 kg
Cable length between electronic unit/cell ⁴⁾	1.5 m (Sub.D 25pin at both sides)
Fuse Power supply with AC/AC adapter and country specific cable Power supply direct (without adapter)	Temperature switch 115 V - 20 % + 15 %, 50/60 Hz, 195 mA, sec. 12 V, 50/60 Hz, 1.25 A 230 V - 20 % + 15 %, 50/60 Hz, 90 mA, sec. 12 V, 50/60 Hz, 1.25 A 9.5 - 17.5 V, 50/60 Hz, 7 VA or 9 - 20 V=, 7 W
Admissible ambient conditions Admissible ambient temperature ⁵⁾ Max. relative atmospheric humidity Height up to above sea level 4000 m	Use only in closed rooms, installation category II, pollution degree 2 5 - 40°C 80 % RH by 30°C

¹⁾ Within the temperature range 10 - 30 °C

²⁾ RS232-C with sep. cable LC-RS9 resp. LC-RS25

³⁾ Control commands according to "Reference Manual MT-SICS" (delivered with LC-RS cable)

⁴⁾ Different lengths on request (max. 10 m)

⁵⁾ Temperature changes may not lead to the formation of water of condensation in the weighing cell or electronic unit.

⁶⁾ Values in fine range

** Production phaseout from May 2000