



Dimensioning, Weighing & Scanning Buyer's Guide

METTLER TOLEDO



Preamble

The guide provides comprehensive Good Dimensioning and Good Weighing Practice™ information to answer the questions "how" and "why" a DWS system can benefit your operation.

This guide is intended to be unbiased and universal in nature. However, there are occasional notes that reflect information about METTLER TOLEDO products. Most often, this is to explain how METTLER TOLEDO systems and components work.

METTLER TOLEDO is not the only company that makes DWS equipment.

However, we believe that METTLER TOLEDO products provide exceptional quality and meaningful innovations. Our hope is that this guide will help you judge for yourself.

Table of Content

Chapter 1	Selecting the Right Equipment	5-10	
Chapter 2	Building a DWS Solution	11-20	
Chapter 3	Initial Costs and Ongoing Performance	21-28	
Chapter 4	Read Rate and Throughput	29-34	
Chapter 5	Site Planning	35-40	
Chapter 6	Project Management	41-44	
Chapter 7	Data Security and Safety	45-48	
Chapter 8	Installation and Certification	49-54	
Chapter 9	Maintenance, Service & Warranty	55-57	

Publisher
Mettler-Toledo Cargoscan
Ulvenveien 92 B
0581, Oslo
Norway

Subject to technical changes
© 08/2021 Mettler-Toledo GmbH

Introduction

Dimensioning, Weighing and Scanning (DWS) systems are used by parcel express companies to identify, weigh and measure the goods they transport. This guide highlights the options available today. It details what should be considered when selecting and implementing a DWS system.

Parcel express companies have different volumes of parcels and different levels of automation. Some measure parcels on high-speed conveyors; others process small items that move in totes or on tilt-tray sorters. Some handle palletized freight; others do a bit of everything. Each terminal has different requirements for barcode reading, conveyor control, integration and weight and volume measurement.

Whatever the application, an express company's DWS system is important to the daily operation of the facilities that use them. Careful selection of the right solution is important—one that can have a direct input on both revenue and operational productivity. This guide is intended to help you to understand and select the right solution, whatever your data-capture needs.

Chapter 1 Selecting the Right Equipment

In order to make informed decisions about a DWS system, it is important to understand the principles of operation. This chapter is designed to provide a basic overview, of the technology, capabilities and performance of equipment available today.

The beauty of today's DWS systems lies in their modularity. Dimensioning, weighing and scanning components can be combined, built up and customized to meet individual application needs. Purchasers should be familiar with the options available to determine which configuration will best meet their operational needs.



Contents

- 1 Main Components of a DWS
- 2 What Does a DWS Provide and Why?
- 3 Determining Which Solution to Use

1 Main Components of a DWS

A DWS system can be made up of any combination of dimensioning, weighing and scanning components. Components are controlled, data is merged by software and accessories compliment the system.

Dimensioner

Dimensioners are either static or dynamic. Static dimensioners measure stationary objects and dynamic dimensioners measure moving items, usually on a conveyor. There are different options available depending on object shape, conveyor speed and width and spacing of parcels.

Scale

Different dynamic-scale options depend on required accuracy, throughput and speed. For static DWS applications, a floor, tabletop or forklift scale is simply interfaced with the other components.

Barcode Readers (Scanning)

Unattended barcode scanners or cameras are typically used in automated processes, with multi-sided reading giving the highest possible read rate. Hand-held barcode readers can be used for manual verification in semi-automated processes or as part of a static DWS.

Data-Management Software

Data-capture software stores data from different components, merges it and sends it to the host. The same software may offer features for improving data-capture processes and further enhancing read-rate and productivity.

Accessories

A DWS system can be complimented with cameras, sensors, traffic lights, data displays and label printers for streamlined processes and clear data display.

Example Dynamic DWS Configuration: TLX MultiCapture™

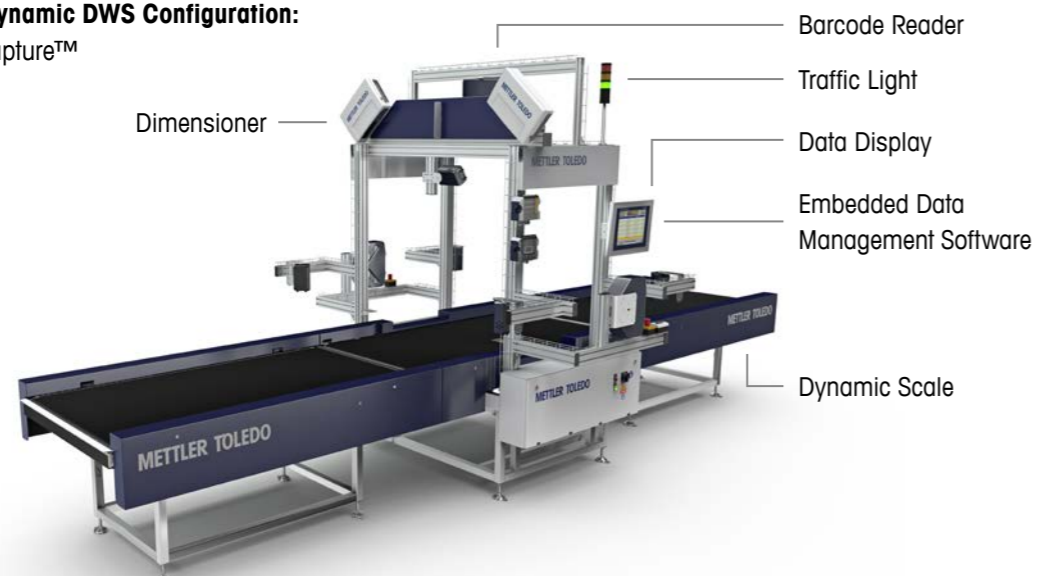

2 What Does a DWS Provide and Why?

A DWS system is typically used as part of a revenue-recovery program, to provide revenue protection to the transport provider and correct, fair invoicing to the shipper.

- Transport providers ensure they are paid properly for the service they provide and that customer-declared weight and size data correlate to that provided by the shipper.
- Shippers are assured that they receive correct and fair invoices for the service they pay for.
- Both parties can be sure that the data used for invoicing is compliant with Weights and Measures regulations.

A DWS system provides weight and length, width and height of an object. It compares weight and dimensions in order for the dimensional weight to be determined. Identification data is captured in order to apply a data profile to each item processed.

Typical Uses of a DWS

Automation of the measuring process

- Verification of customer-declared weight and size data
- Check data against profile in customer database
- Compliance with Weights and Measures regulations
- Track and trace of shipments
- Check for missing parts in a shipment

Identification (ID)	Capture item ID for correct sorting, tracking and allocation of weight & size data
Weight	Verify weight data for invoicing, load planning and quality checks
Dimensions	Verify measurement data for invoicing and load planning
Dimensional Weight	Divide volume by a dimensional factor* to determine an object's dimensional weight
Billable Weight	Compare dimensional weight with actual weight to determine the billable weight
Shape	Record shape data to reject an item that is too large to be sorted or that requires a surcharge because it is un-stackable.
Image	Take a picture of items measured for proof of correct invoicing and package condition

* The international Air Transport Association established a standard dimensional factor, however companies may choose their own.

3 Determining Which Solution to Use

When deciding which DWS solution is right for your operation, start by taking a look at current processes. Consider how many parcels are processed and their shape and size.

Ask yourself the following questions:

- What type of objects are handled (parcels, pallets, etc.)?
- Are you using weight and dimensions to charge back customer (i.e. Legal-for-trade application)?
- How many items are processed daily?
- How many items are processed during peak hours?
- What shape are the items that pass through the facility?
- What is the current level of automation?
- What is the speed of your sorting equipment?
- Where is there the possibility to further automate processes?

Answering each of these questions will help you determine which equipment to implement.

What kind of Items do DWS systems typically handle?

A DWS system can be used to identify, weigh and dimension almost any item. Any configuration can be built up such as dimensioning and identification, identification and weighing, or with all three data capture elements: dimensioning, weighing and identification.

There are combinations available to effectively process:

- Singulated, cuboidal shaped parcels moving on a conveyor at speeds up to 3 m/s*
- Singulated, irregular shaped parcels moving on a conveyor at speeds up to 3 m/s*
- Parcels placed individually on a tilt tray sorter*
- Parcels or small items in totes on a conveyor
- Parcels or items measured while stationary
- Pallets, containers or other large items measured while stationary

The difference between static and dynamic DWS

While the measuring process and data transfer is automatic in both cases, static DWS systems require some manual operation, in which an operator places the object onto the system and removes it again after measurement. Dynamic DWS is an automatic process that is typically performed without manual intervention or a dedicated operator.

In some cases a dynamic DWS system can be configured to stop if a parcel is missing vital data so that an operator can intervene and enter missing information. In highly automated processes, the system can send a signal to the sorter to divert a package that it was not able to read or measure for re-sort or for a manual check.

The Objects You Handle

Shipments come in all variety of shape, size, color and material. Goods can roughly be classified into:

- Conveyables
- Non-conveyables
- Palletized
- Regular
- Irregular

Conveyables are objects that can be easily handled by one person and placed onto a conveyor belt, table or into a vehicle. They are usually solid in shape and ride smoothly on a conveyor. Non-conveyables are items that are inconvenient for one person to handle. Examples include heavy boxes, tires, chests, bicycles or cans. Palletized goods are objects placed on a pallet or a skid because the size, shape, weight or quantity make it impossible for one person to handle.

Regular vs. Irregular Dimensioning

Dimensioners are either approved for measurement of regular shapes or all shapes. If a dimensioner cannot see a whole parcel or pallet, it cannot measure irregulars accurately. The diagram below shows how a dimensioner for regular objects only misses some of the detail of the item being measured. It is important to make sure that the equipment you select is suitable for measuring the shape of goods that you handle.

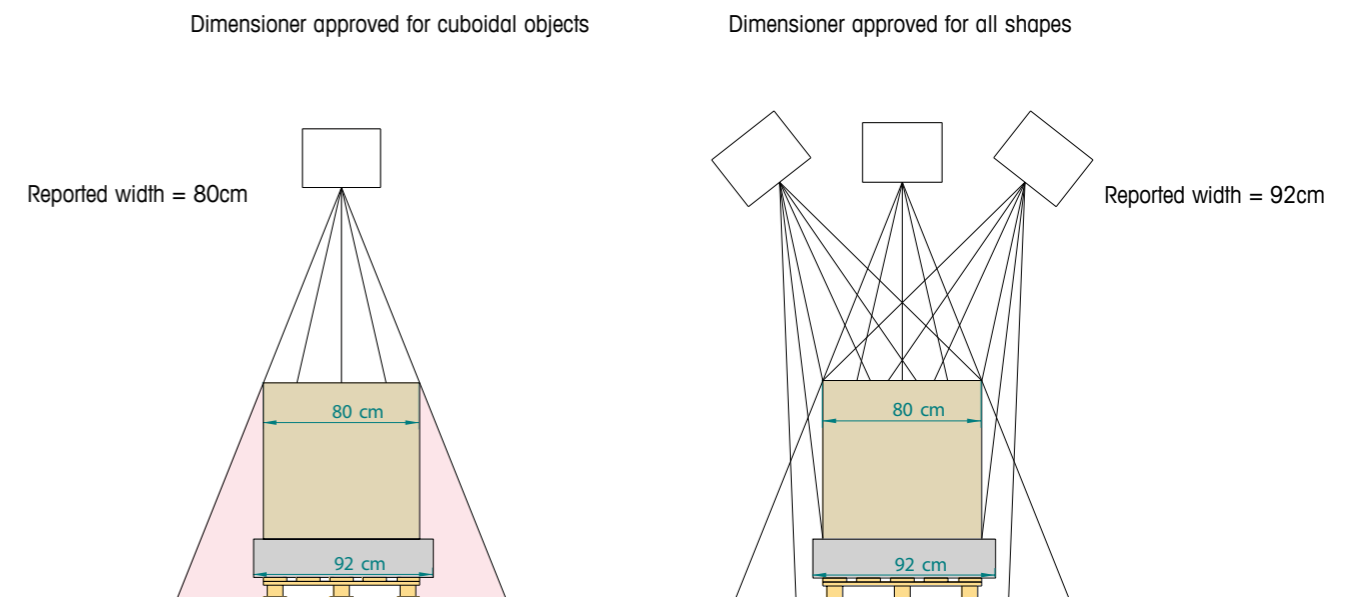

*For TLX Advanced, 2m/s and TLX Basic, 1 m/s.

Measuring Different Surfaces

In addition to shape, it is important to consider whether a measuring solution can provide sufficient accuracy on all surfaces. Some technologies struggle to provide accurate measurement of items that are wrapped in shiny, reflective plastic, or that have a surface color that blends into the measuring background. This topic is addressed further in Chapter 3 in the section that addresses the importance of read rate.

Barcode Type

Take into consideration the quality of barcodes when selecting equipment. If you label parcels yourself, you have better control over barcode quality. However, barcode quality of customer-supplied labels can vary dramatically depending on the printing technology, label geometry, point of origin and other factors. Parcels that have been handled excessively before delivery may be torn or smudged. Some laser scanners can solve quality issues by stitching multiple scan lines together to reconstruct a damaged code. Image barcode readers compensate for damage to the code or light reflections from the package using analysis software that reconstructs required data from any legible portion of the image.

Throughput

The type of system you select will also depend on speed and throughput requirements. In mid-level automation applications, manual intervention may be possible, in which case the need for fully automated solutions is lower. Software can send a signal to stop the belt if data is missing to allow an operator to key it in manually. In highly automated processes in which maximum throughput is the goal, we recommend having a larger number of barcode readers that see the package from multiple sides.

Throughput and conveyor speed are usually inversely proportional to weighing accuracy. Sometimes a compromise has to be made between accuracy and conveyor speed/throughput. In order to maintain high weighing accuracy at high throughput, a solution is to divide the line over multiple scales or to implement a dual-scale solution. Dividing the line reduces the throughput over each weigh cell, while maintaining constant throughput for the system.

Chapter 2

Building a DWS Solution

From cost-effective static solutions that automate the data-capture process in a manual-handling environment, to fully automated weighing, measuring and barcode reading tunnels, it is possible to build up a DWS solution for any transport and logistics application.

A DWS system can be built up using any combination of dimensioning, weighing and scanning components. The best solutions are modular and can be customized to suit specific operation and information requirements.

**Contents**

-
- 1 Dimensioning Options

 - 2 Weighing Options

 - 3 Scanning Options

 - 4 Example Configurations

1 Dimensioning Options

There are three main aspects to consider when considering dimensioning technology.

- Whether or not the technology can measure the shape of goods processed
- The number of measurement points captured
- Whether the device uses a shadowing, or a reflective technique.

Measurement Points

Devices can be differentiated by the number of measurement points that are created during measurement. The more points a device generates, the more precisely it can determine the dimensions of an object. Figure 2.1 demonstrates how the higher the number of measurement points, the more precisely a dimensioner sees an item.

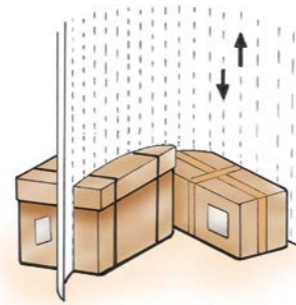

Figure 2.1

Positioning of Measurement Points

A device's design must try to optimize the position of the measuring points so that the important details of an object are recognized. Some technologies use parallel light beams to characterize the object while others use angled beams. Parallel beams see a more representative view of an object's characteristics. Angled beams can easily be shadowed by the edges of an object and the beam may be blocked from seeing important details.





Shadowing vs. Reflective Technology

With shadowing technology, the object interrupts a light path and a shadow profile is observed by the device. This method works with all objects regardless of object surface.

Reflective devices use a type of radiation that is reflected back from the object. There are materials and surfaces that absorb or reflect too much or too little radiation to allow good measurements. By modulating the radiation, a device can measure more surfaces, and is less sensitive to background radiation. A reliable reflective device should be able to tell when a surface reflects too little or too much radiation.

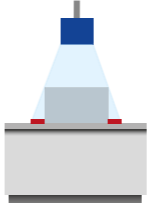
Light Curtain Technology

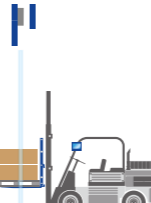
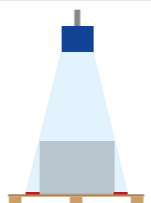
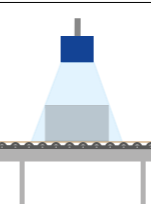
A shadow parallel beam technology that uses hundreds of measuring points on the top and the sides of an object. Very small precision ranges can be obtained with this technology. Light curtains consist of arrays of infrared emitters and receivers. Infrared transmitters are placed on one side and transmit their radiation to the receiver on the other side. One transmitter and the corresponding receiver are active simultaneously. As the object is moved through the device on conveyors, the silhouettes are stored in a computer.

Recommendation	Application	Explanation
	Static parcel dimensioning	In low- to medium-throughput applications, either a tape-measure dimensioner or a tabletop dimensioner can be used to automate measurement and data transfer.
	Static pallet dimensioning Legal-for-trade applications	In legal-for-trade applications, three dimensioning heads see the pallet from all angles for accurate measurement of all shapes.
	Dynamic pallet dimensioning Legal-for-trade applications	In legal-for-trade applications, four dimensioning heads measure the pallet from all angles while it is in motion for accurate measurement of all shapes.
	Static pallet dimensioning Non-legal-for-trade applications	In non-legal-for-trade applications, one dimensioning head can provide sufficient accuracy with some limitations.
	Dynamic parcel dimensioning High-speed singulated regulars	One dimensioning head is sufficient for accurate measurement of cuboidal packages moving at high speeds on a conveyor.
	Dynamic parcel dimensioning High-speed singulated irregulars	A multi-headed dimensioner will see items moving on a conveyor from different angles for accurate measurement of irregular shapes.

2 Weighing Options

Despite the widespread use of scales in transport and logistics, there are few guidelines available to help users evaluate a scale or compare the capability of different brands of machines. There are three main considerations when choosing weighing technology for transport and logistics:

- Speed and throughput
- Weighing resolution
- Maximum weight

The accuracy of a dynamic weighing solution is directly linked to speed and the stability of the items being weighed. Up to a point, accuracy increases as conveyor speeds and line throughput decrease. The more stable an item is during weighing, the higher the accuracy.

Weighing Technology Options

There are many different weighing technologies, but the two most common load cells used in dynamic scales are strain-gauge load cells and load cells that use the principle of force restoration. For legal-for-trade applications where high accuracy is required at high speed, electromagnetic force-restoration technology is recommended.

Strain-Gauge Load Cell

The strain gauge load cell has two major components: Flexures on a load bearing surface and a strain sensor. Load cells are often provided with external mechanical overload stops to prevent damage to the load cell if the load exceeds the weighing capacity. The strain-gauge load cell measures the strain (Figure 2.1), or proportional displacement of sensors within the load cell, resulting from a load on the weighing platform. The strain is measured as a small voltage output. The output varies linearly along the weight capacity of the cell as load is added or removed from the weigh conveyor. The controller translates the voltage to a meaningful weight based on the system calibration.

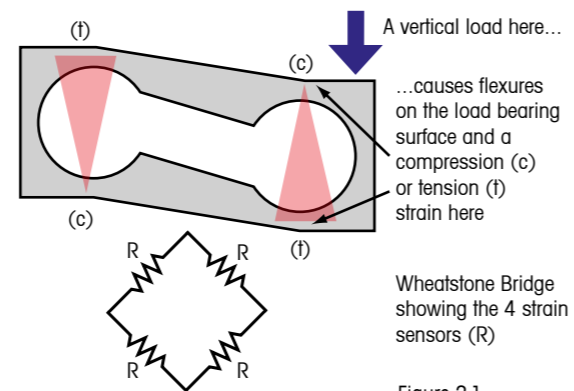

Electromagnetic Force Restoration (EMFR)

EMFR load cells gain their significant advantage by using the latest enhancements in weighing technology to improve performance and provide sustained accuracy. EMFR load cells are intelligent sensors that control and compensate for a variety of elements that can influence weighing performance, such as temperature, noise and vibrations.

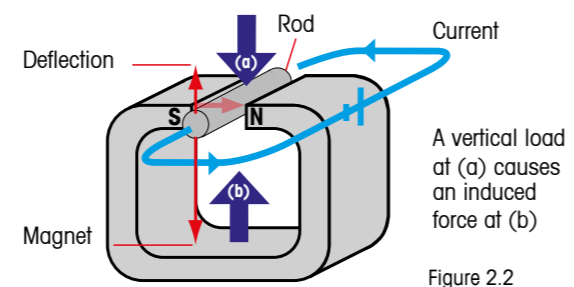

EMFR weighcells are equipped with a high-performance digital signal processor, which allows for the use of advanced software-filtering techniques. These filter algorithms make it possible to sample or take more readings of the weight of a package as it passes across the scale. The more times you can “look” at the weight of the package, the more accurate you can expect the final weight result to be.

The Strain-gauge load cells have undergone tremendous improvements during the last years and have become more accurate and responsive. There are a variety of strain-gauge load cells available, and in some applications, they may be better suited for an installation due to their smaller size and simplified mechanical integration.

Throughput

Throughput is important when considering the right load cell technology to use. The higher the throughput, the less time there is to stabilize and weigh each package. Dynamic scales run at throughput rates up to 18,000 parcels per hour. The longer the item, the faster the conveyor must move to maintain throughput. Using a shorter weighing section helps minimize conveyor speed while maintaining optimal throughput. Software can send a signal to a separation belt to ensure that spacing is sufficient to weigh one item at a time. A dual scale will increase throughput without the need to increase speed.

Recommendation	Application	Explanation
	High-speed dynamic weighing	High-speed dynamic scales deliver throughput of up to 11,000 pieces per hour.
	High-throughput dynamic weighing Dual scale	Conveyor is split into two weighing stations to achieve higher throughput without increasing the speed.
	Static-parcel weighing	Bench- or floor-scale options provide accurate weight data when an object is placed on to the weighing platform.
	In-motion pallet weighing	Forklift and pallet jack scales weigh pallets on the move, eliminating the need to place the pallet on the floor to be weighed.
	Static pallet weighing	Floor scales statically capture weight data of pallets and larger items.

3 Barcode Reading Options

There are barcode-reading options available for a variety of budget and performance requirements. The higher the speed and level of automation, the more value there is in investing in high-performance barcode-reading solutions.

When selecting barcode readers for a DWS system, it is important to consider the following:

- Required minimum barcode resolution
- Height and length ratio of barcodes
- Placement of barcodes on a parcel or pallet
- Level of automation and possibility for manual intervention

Laser Based Scanning

A laser scanner reads a barcode by measuring the size of printed modules using light reflected from the code. One of the method's most potent advantages is its simplicity. Its popularity stems from the fact that it is easy to set up, connect and aim and it can read codes fast enough to accommodate high speeds. These systems also achieve a large scanning area and working range.

Resolution

Laser-based barcode readers come with three different minimum resolutions: 0.25 mm*, 0.30 mm and 0.38 mm. These values refer to the minimum width of a line in the barcode, or the minimum spacing. The wider the spacing and thickness of the lines, the higher the minimum resolution should be. A 0.25 mm resolution barcode reader can also read less dense barcodes, but it will have a smaller reading area and so more 0.25 mm readers are required to cover an area than if using a barcode reader with higher resolution.*

Barcode Requirements for Laser-Based Scanners

Laser based barcode readers have limitations when it comes to read rate. In order to be read by a laser-based barcode scanner, the barcode should have the following characteristics:

- Code quality ANSI grade B or higher
- Made of paper and not displayed in a plastic case
- Limited variation of the code skew and pitch angle (+/- 20°)
- Clear of straps or other objects
- Undamaged

Image-Based Barcode Readers

Image-based barcode readers can offer a higher read rate than laser scanners due to their ability to successfully read codes degraded by damage, orientation or distortion. To compensate for damage to the code or light reflections from the package, analysis software reconstructs the data from any legible portion of the image.

*Not Standard for the TLX.

2D Barcodes*

An emerging trend in the logistics industry is the introduction of two-dimensional (2D) codes, such as Data Matrix and PDF417. Certain regulated industries, such as the pharmaceutical industry, will likely be required by law to use these codes to combat drug counterfeiting. The amount of information that 2D codes can store makes them very attractive for a wide range of applications, and image-based scanners are required to read these symbologies.

Scanning Configurations

In addition to deciding which technology to add to your DWS system, it is important to choose the correct scanner configuration. An overhead barcode reader, which measures labels placed on the top of a package is the minimum for a dynamic application. If packages received are already labeled when they arrive at a facility, there is less control over where the barcode is positioned on the box, which makes it harder to ensure the barcode is read. In highly automated hubs, there may be no possibility for operator intervention in which case a barcode reading tunnel with scanners placed on all sides is required.

Barcode Validation

Barcodes need to be "validated." This allows the data-management software to recognize barcodes that are specific for the transport company and ignore those which are not. To validate a barcode, the software uses a set of criteria, such as code type or defined characters, that can uniquely distinguish the customer bar codes from any other barcodes. Checksum calculations may also be used.

Example Scanning Configurations



Top and side reading



Five-sided reading tunnel



Top reading

*Not Standard for the TLX.

4 Data Management

Data management software is used to transfer, merge and store data from the different components of a DWS system.

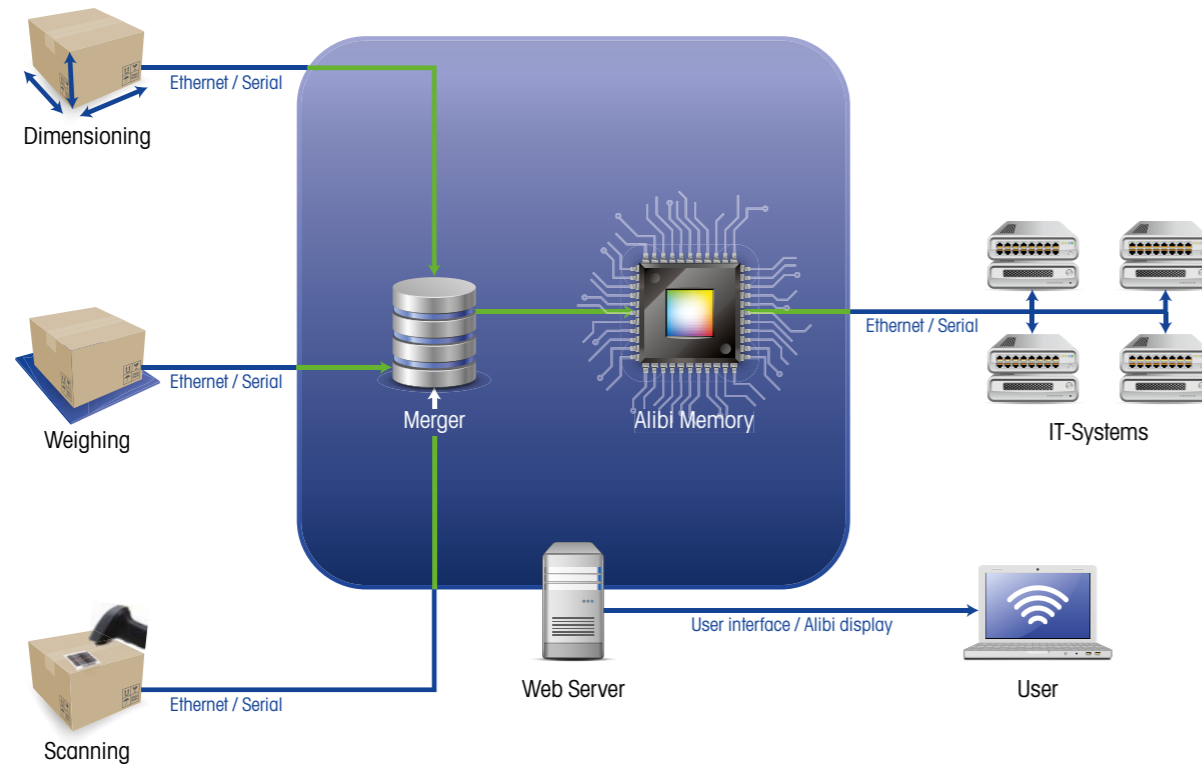

In addition to this basic functionality, there are certain software features to look out for which aid sorter efficiency.

Predefined data drop

Application software can be configured for parcel data to be sent to the host at a predefined time within two-to-three milliseconds of a package passing a particular point on the sorter. Because you can control when the data is sent—either upon reading, or once the package has moved a particular distance down the line—the next correct action can be taken for a particular scanned package.

Parcel positioning

For maximum sorting efficiency, it is important to know where a parcel is on the belt, what size it is, and at what angle it is being presented. Items that are side-by-side on a conveyor can cause delays, damage, miss-sorts and incorrect data profiles. Software which can detect when two packages are travelling side by side can report the problem to the host and redirect the problematic items to avoid sorting mistakes. The same software should also detect if an object is outside of the measuring area, if an object is too small to be measured or too big to down a sorting line.

Sorting and Tracking Commands

Sorting can be controlled using commands by destination code, product code, etc. to ensure that each package gets to the right destination on time. These commands can be used to reject parcels that do not fit a certain profile.

System Health Monitoring

Health monitoring software provides full visibility into the performance of all components of a dimensioning, weighing and scanning system. If something goes wrong with the scale, dimensioner or barcode reader, the software sends an alert resulting in quick action to fix the issue.

Operational Statistics

Measurement statistics allow analysis by shift, day, week and month help with planning, trend analysis and customer communication. Information related to parcels weighed and measured, throughput, no-reads and errors enable operational improvement actions and provide valuable information for planning future investment.

5 Example DWS Configurations

The beauty of today's DWS solutions lies in their modularity. Almost any combination of scales, dimensioners and barcode readers is possible. Here are some examples of common configurations for different applications.

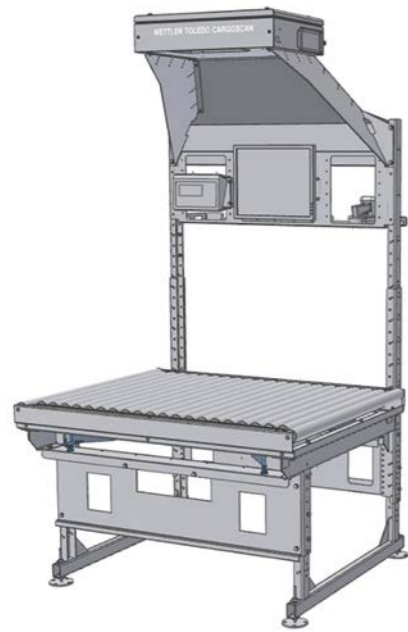

Static Parcel DWS

- Overhead dimensioner
- Tabletop scale
- Handheld barcode reader
- Data-management software

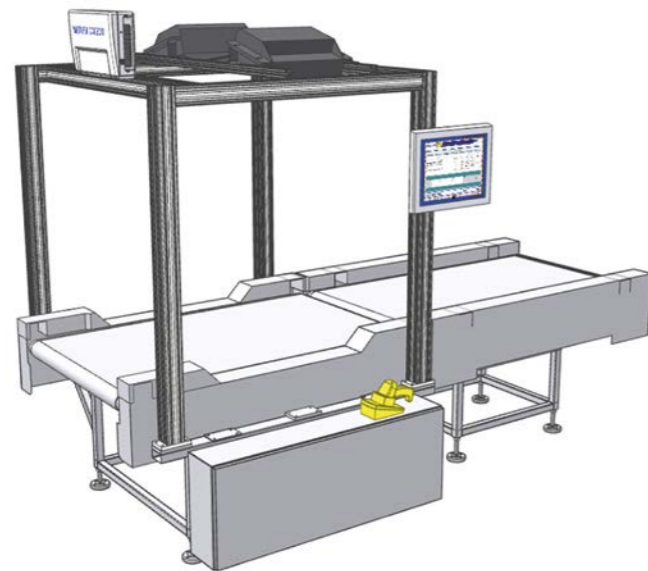

Dynamic Parcel DWS Mid-Level Automation

- In-motion dimensioner
- Dynamic scale
- Top barcode reader
- Manual verification
- Data-management software



Dynamic Parcel DWS, Fully Automated, Regular Shapes

- In-motion dimensioner
- Dynamic scale
- Five-sided barcode reading
- Data management software
- Image capture



Dynamic Parcel DWS, Fully Automated, All Shapes

- In-motion dual-head dimensioner
- Dynamic scale
- Five-sided barcode reading
- Data-management software

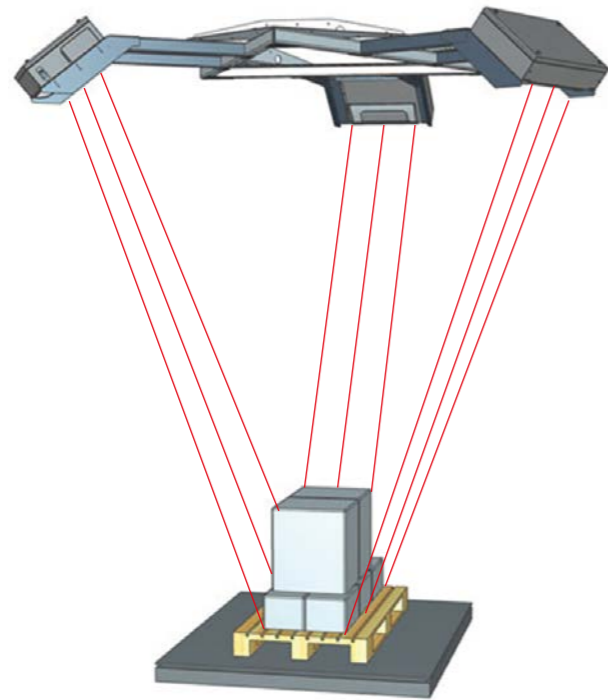

Static Pallet DWS, All Shapes

- Three-headed dimensioner
- Floor or forklift scale
- Handheld barcode reader
- Data-management software



Dynamic Pallet DWS, All Shapes

- Four dimensioning heads
- Forklift scale
- Integrated barcode readers
- Data management software

Chapter 3 Initial Cost & On-going Performance

An informed purchaser considers more than just the initial purchase price when comparing DWS solutions. While price is important, it is the read rate and reliability of the equipment that will have a direct impact on business for years to come.

Calculating the total cost of ownership over the life of a DWS system should also factor in downtime, repair and service costs, and the added revenue that the system brings to your business. Choosing a system that offers the highest possible read rate and accuracy guarantees maximum revenue recovery.



Contents

- 1 Project Costs
- 2 Read Rate and Accuracy
- 3 Reliability
- 4 Uptime

1 Project Costs

Whether investing in new equipment or replacing old, it is important to build a solid business case before making a capital investment. Management and decision-makers prefer to see hard evidence that shows the new equipment's Total Cost of Ownership (TCO). Total Cost of Ownership calculations are fundamental when evaluating new equipment and can guard against unpleasant surprises later on. It is essential when purchasing a DWS system to expand the scope of cost considerations beyond the initial investment. The TCO model should take into account the direct and indirect costs and savings associated with the equipment that will be a result of the investment. Only when these factors are considered can a Return on Investment calculation be accurately established.

Defining Costs

The first year of ownership is the most expensive because it includes expenditures, such as the cost of equipment, installation, spare part kits and sorter integration, which may include the use of consultants and sometimes the disposal of old equipment. After the first year of ownership, operating costs, maintenance costs including replacement of worn parts, unscheduled downtime and extended warranties can add ongoing cost. Weights and Measures costs for conformity assessment procedures and periodic official inspection and calibration may also be necessary. The evaluation of these costs is the basic for all future economic calculations, such as TCO and overall operational profitability.

Defining Savings

The savings that can be made when implementing the right DWS system are strongly dependent on whether you are replacing an existing system with a newer model, or replacing a manual or static measuring process with a dynamic DWS solution. The main financial benefits of a DWS are obtained through revenue recovery and improved productivity. Other savings, while important, can be more difficult to quantify. By bringing visibility to billing practice, a transport company builds a reputation as a provider to trust, reducing costs related to customer claims and disputes. Further savings are made by reducing manpower and paperwork.

There are many variables to incorporate into a proposal for TCO and evaluation of savings. Equipment, installation and training costs should be readily available; the equipment supplier should be able to provide guidance on expenditures such as operation and maintenance costs and unscheduled downtime. Also consider the read rate, accuracy and reliability of equipment at this stage of the project. The more parcels or pallets your system can adequately process, the greater the financial benefits will be.

Overview of costs and savings when implementing a DWS solution.

Costs				
Initial Investment Costs	Year 0	Year 1	Year 2	Year...
Equipment purchase		-	-	-
Installation/Start up		-	-	-
Validation documents		-	-	-
Weights and Measures costs (where applicable)		-	-	-
Training on supplier or customer premises		-	-	-
Initial spare part kits		-	-	-
Maintenance contract		-	-	-
Production line integration		-	-	-
Disposal of old equipment		-	-	-
Total		-	-	-
Following Years (usually up to 5 years)				
	Year 0	Year 1	Year 2	Year...
Operation costs	-			
Maintenance costs	-			
Unscheduled downtime	-			
Extended warranty	-			
Periodic legal verification (where applicable)	-			
Software/Hardware updates	-			
Total	-			
Savings				
Savings	Year 0	Year 1	Year 2	Year...
Revenue Recovery	-			
Re-sort reduction	-			
Labor reduction	-			
Reduction of miss-sorts	-			
Brand and customer relationship protection	-			
Total	-			

2 Read Rate and Accuracy

The higher the read rate of your DWS system, the higher the potential for both revenue recovery and smooth parcel flow. Read rate will have a direct effect on return on investment. To ensure maximum read rate, when evaluating a solution, consider whether it can:

Measure All Shapes

Technology that uses a scanning pattern will capture details for accurate measurement of all shapes. Another option is to install multiple scanners mounted at an angle so that their beams cover the item from all sides. Large optics let in more light for accurate measurement of a wider range of items.

Measure All Surfaces

To ensure optimum revenue recovery, make sure the dimensioner you choose can measure all surfaces. Some dimensioners are “blinded” by reflective surfaces and won’t produce accurate results on dark surfaces such as black and blue, and will not accurately measure items wrapped in clear or black plastic. A reliable dimensioning device should accurately measure objects with surfaces that are:

- Dark in color
- Light in color
- Shiny/polished surfaces
- Transparent surfaces like glass or plastic
- Rough/spongy surfaces
- Tape

Determine what type of materials commonly go through your sort and ask your vendor to specify which types of surfaces may give false results when measured.

Decode Damaged Barcodes

Poor barcode quality, insufficient contrast or damage to the label may make reading the barcode difficult. Image-based barcode readers can reconstruct data of interest on codes degraded by damage, orientation or distortion to ensure best possible read rate of barcodes.

Measure at Low Speed

In a typical parcel handling environment, the belt will occasionally be stopped during a sort. Ensure that no packages are missed by choosing a system that can measure down to 0 mps. If a system can only weigh and measure packages moving above a certain belt speed, any item moving through the system as the conveyor slows down or restarts will not be measured.

The Financial Impact of No-Reads

When a system does not manage to read the barcode or record required data, the parcel must be diverted to a station where an operator can manually key in the information or replace the defective barcode with a new barcode and resend the package back through the sorting system. This inevitably results in increased labor costs and reduced efficiency of automated sorting equipment. If a dimensioner fails to measure the package, potentially inaccurate customer declared data must be used for invoicing and the potential for revenue recovery is lost.

3 Reliability

The Importance of Repeatable Results

Repeatability is also sometimes referred to as precision. This is the system’s ability to generate consistent results over time. Using the same 100 gram weight, if you place it on and off a scale 100 times, how many times would you get a value of 100 grams in dynamic operation mode? It is the same with dimensioning. If you place the same 50 x 25 x 25 cm box underneath the dimensioner, how many times will it provide the same measurement result?

Plotting accuracy and precision is similar to target practice; the closer you are to the bullseye, the more accurate the results. Each hit on the following diagrams symbolize one weighing of a particular item. The following test scenario uses four dynamic scales in which an item is weighed five times on each. The center of the target symbolizes the static weight of the item measured on a calibrated static scale.

Figure 3.5 shows a dynamic scale with inaccurate and unrepeatable results. The results are not grouped together, or near the center of the target. Generally, if such a result occurs, it means that something has failed and requires immediate attention.

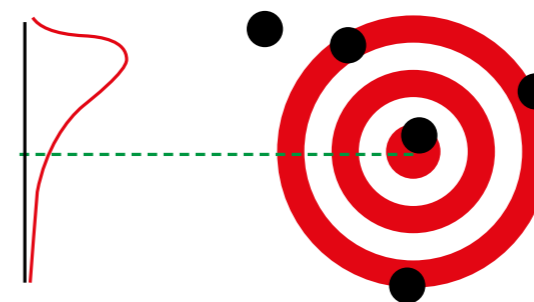

Figure 3.5

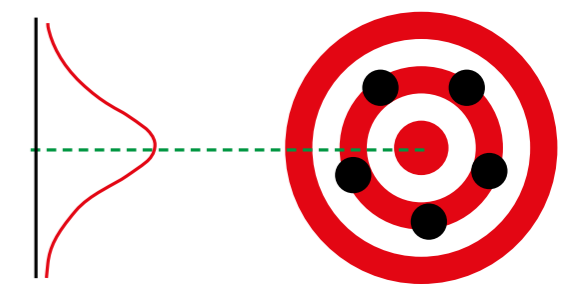

Figure 3.6

Figure 3.6 shows a dynamic scale with accurate but unrepeatable results. The results are grouped loosely around the target and would yield a performance curve that would be characterized by a very low mean error and a high standard deviation.

Figure 3.7 shows a dynamic scale with repeatable but inaccurate results. The results are closely grouped but off-center. Figure 3.8 shows a dynamic scale with results that are accurate and repeatable. All results are closely grouped around the bullseye, showing high accuracy and low standard deviation for the most reliable result.

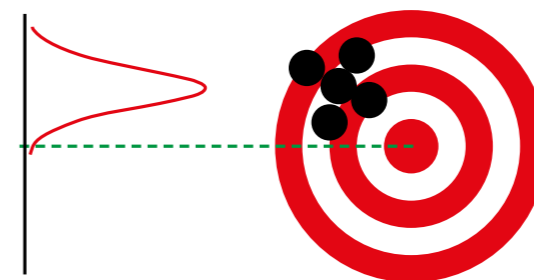

Figure 3.7

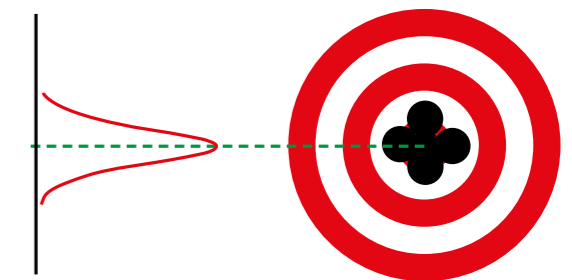

Figure 3.8

4 Uptime

A DWS system makes money for the company using it. Therefore, every hour of downtime is costly. There are a number of hardware and software features available to maximize uptime and to make service, when it is needed, as quick and efficient as possible.

Robust Hardware Design

The design of equipment should be rugged and fit for purpose in an industrial environment. IP54 is the minimum protection requirement against dirt and dust, moisture and humidity. Choose equipment that has a minimum number of external moving parts, as those can be subject to wear and tear and may require additional maintenance to keep them free from the danger of dust or debris clogging up the mechanics.

Remote Diagnostics

Some software offers features, such as health monitoring and remote diagnostics. Health monitoring software will monitor the pulse of all components of a system so that if something goes wrong with the dimensioner, scale or barcode reader, an alert will be sent to the operator. Remote diagnostics allow a service technician to access the system remotely in order to identify and fix problems quickly.

Virus Protection

Linux-based operating systems offer the advantage of being resistant to known viruses and will ensure that performance is not affected by software viruses or bugs. If you choose a Windows-based operating system, it is important to install a virus-control software package that will need to be maintained to ensure continued protection and performance. However, Windows Embedded versions running on read-only flash memory do not require additional virus software.

Parcel Positioning

In a dynamic application, knowing where a parcel is on the belt, its size and its angle, is not only important for maximizing sorting efficiency, but also for avoiding jams that can stop operation. Parcel positioning and side-by-side detection are advanced software features that can be used to reduce jams and improve tracking throughout the system. If a parcel is too big to travel down an out-feed, or if multiple packages are travelling together, they can be redirected out of the main sorter to prevent damage to the belt or before a jam situation occurs.

Replacement of Parts

Quick and easy replacement of parts is fundamental to maintaining uptime in the case of a system failure. A DWS supplier should offer information about replacement times, availability of spare parts, emergency service and recalibration to allow you to assess the impact of a system breakdown and plan accordingly.

Chapter 4 Read Rate and Throughput

The previous chapter addressed the different dimensioning, weighing and scanning options available as part of a DWS system. This chapter discusses the importance of achieving a high read rate with dimensioning and scanning components and how your choice of scale plays a key role in maintaining high throughput.

Optimizing throughput is the goal of any sorting operation. Barcode reader and dimensioner read rate can significantly impact sorter efficiency. Similarly, the wrong scale can slow down operation. There are key features to look out for when choosing DWS equipment, which will help to ensure that the entire operation runs optimally.



Contents

- 1 Barcode Read Rate
- 2 Dimensioning Read Rate
- 3 High Throughput Weighing

1 Barcode Read Rate

Barcode read rate is crucial for productive operation in an automated sorting line. When a barcode reader does not successfully read a barcode, the parcel must be diverted to a station where an operator can replace the label or manually enter barcode information. By increasing read rates even by a small percentage, fewer packages will require manual handling and fewer workers will be required for relabeling or rerouting rejects.

The table below highlights the cost impact of achieving higher read rates of just a few percent:

Read Rate	No-Reads	Maximum Number of Packages/Day	Total Rework Time (Man/Hours/Day)	Number of Operators Required for Rework	Cost of Operators (USD/Year)
97%	3,802	122,918	95,05	11,9	499,012.50
98%	2,535	124,185	63,38	7,9	332,715.75
99%	1,286	125,452	31,70	4,0	166,425.00
99.5%	634	126,086	15,85	2,0	83,212.50
99.9%	127	126,593	3,18	0,4	16,668.75

Impact of 1% higher read rate (from 98% to 99%)

Number of parcels reworked per day reduced by	1267
Number of parcels reworked per year reduced by	443,450
Operator cost savings per year	\$166,290.75

Laser-Based Barcode Reading

A laser scanner emits a laser beam toward the black and white bars of the barcode. Because black absorbs light, and white reflects it, the light that is received back tells the encoder the width of each line. The information is then decoded and translated into characters containing package information.

One of the method's most notable advantages is its simplicity. Its popularity stems from the fact that it is easy to set up, connect and aim, and it can read codes fast enough to accommodate high speeds.

Laser systems provide high read rates given that barcodes are of good quality and labels are undamaged. However, they may have difficulty reading codes that have been scratched, smudged, wrapped in plastic or badly printed. Printed barcode quality can vary dramatically depending on how the package is handled, the printing technology, label geometry, point of origin and a host of other factors. Insufficient contrast, for example, may not provide enough difference between a printed and non-printed code to permit an accurate read. Because a laser scanner uses a single laser line to decipher the code, light, reflectivity or damage to the code may reduce the scanner's ability to read the code successfully. Some laser scanners get around this issue by using reconstruction algorithms that make assumptions about the barcode pattern using any undamaged information available. This method works well, but not when damage is severe.

New generation laser scanners transfer analogue signals to Digital Signal Technology. This allows the processor to refine the code information, improving optic capabilities for higher read rate on low quality codes.

Autofocus vs. Multiple Laser Diodes

Some barcode readers use autofocus to zoom in on the barcode based on height information provided either by a dimensioner or encoder input. Newer technology uses multiple laser diodes to provide a larger natural reading depth. This allows them to read barcodes at different distances simultaneously. Examples of this include when multiple packages are in the reading area at the same time or when packages of different heights are next to each other. An autofocus mechanism is unable to read multiple codes with the same laser diode at different distances.

Polaroid Filters

It can be challenging to decode the barcode if a code is placed under shiny plastic due to the excessive light reflected back to the encoder. The best laser scanners have double Polaroid filters, which reduce light reflection from shiny surfaces. Think of it as sunglasses for your scanner.

Camera-Based Barcode Reading

Sorting hubs that struggle with no-reads can upgrade to image-based readers. The cameras assemble a high-resolution image of a package surface—containing a code—one line at a time as it passes through, analyzing the image to locate and interpret a valid code regardless of its orientation or its placement on the package.

From the onset, image-based readers begin with more information about the barcode. This head-start allows them to successfully read codes degraded by damage, orientation or distortion. To compensate for damage to the code or light reflections from the package, the analysis software can reconstruct the required data from any legible portion of the image.

Use Image Information to Further Improve Read Rate

Image-based systems can also store images for later retrieval and analysis. Archiving this information helps a sorting facility to determine the root cause for any unread barcodes and implement corrective action, reducing the number of subsequent misreads. For example, if it is discovered that package handling issues account for a high number of no-reads, supervisors can modify operating procedures for loading packages onto the sorting conveyor and significantly reduce that number.

2 Dimensioning Read Rate

The dimensioner of a DWS system is the component which offers the greatest revenue potential for parcel carriers. When you consider the number of parcels measured in a typical shift, and the average revenue recovered per item, even seemingly small improvements in dimensioning read rate can add considerable value to your process. When the number of no-reads is multiplied by the number of sorts each day, week or year, it pays to make sure that as many parcels are seen by your dimensioner as possible. In a typical sort there will be objects which are wrapped in black plastic, packaged in blue or black boxes, or covered with white or shiny reflective wrapping. These are the types of goods that potentially pose problems for some dimensioners. If you handle any of these items, it is important to make sure that your dimensioner can too.

The Difference is in the Dynamic Range

The breadth of surface types a dimensioner can accurately and precisely measure is referred to as its dynamic range. The wider the dynamic range of a dimensioner, the more items it can accurately measure. In some cases, items which fall outside of a dimensioner's dynamic range are simply passed as no reads and are either sent through the sorter again, redirected for manual processing or go through without being measured.

A dimensioner's dynamic range is depicted by the following table. The numbers represent the percent reflection an object's surface generates.

Dimensioners with the Widest Dynamic Range

Surface Type	Reflectivity %
Stainless steel	200
White diffused	95
Light grey	80
Mid grey	48
Dark grey	35
Black copier paper	10
Black rubber	7
Black anti static foam	4
Black velvet	2

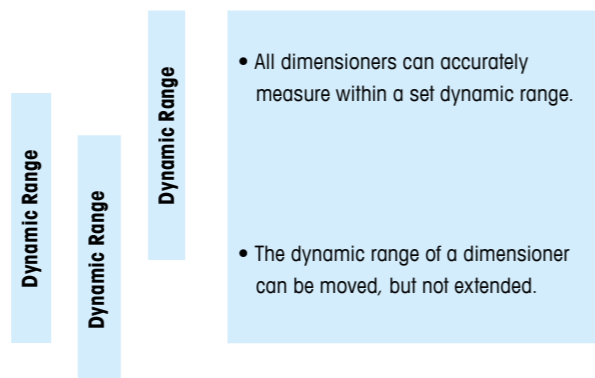

Accurate Measurement of Dark Surfaces

Dark surfaces absorb the laser and return less light to the dimensioner, resulting in a low signal-to-noise ratio. The larger the optics of a dimensioner, the more light it receives back, increasing the signal to noise ratio. In other words, the lack of light sent back by a dark colored object can be compensated for by increasing the receptor size and letting in more of the available light. Dimensioners which experience problems reading black will have the same difficulty measuring blue surfaces. The red laser sees the color blue as black.

Accurate Measurement of Reflective Surfaces

While dark objects absorb light, shiny objects reflect it. If the light is reflected towards the dimensioner, it may blind it. To handle reflective surfaces more easily, laser sensitivity can be adjusted. However, this compromises the dimensioner's ability to measure dark objects. Think of adjusting laser sensitivity like setting the exposure level on a camera. If the exposure is set too high, it will see the dark objects in a room, but it will be blinded by the bright areas. Reducing the sensitivity makes it more difficult to see the dark objects in a room.

A dimensioner which automatically compensates for over-exposure has the ability to read reflective surfaces without being blinded. This means that when the laser enters a bright area, the dimensioner reduces its sensitivity before the receiver is saturated. When the laser leaves the bright area, the sensitivity is automatically increased again.

A reflective object which is angled may reflect the light away from the dimensioner, causing it to receive too little light. This can be compensated for with large optics, in the same way as measuring items with a dark surface.

The Impact on Revenue and Productivity

Parcels processed per day	20,000
Operating days per year	250
2% better read rate	€ 0.5 per parcel
Extra revenue recovered annually	€ 50,000

Revenue Gains of High Read Rate

The more parcels a dimensioner can accurately measure, the more revenue it can recover. If just two percent of the items processed fall outside of the dynamic range of the dimensioner, this can add up to thousands of euros worth of missed revenue recovery. The example below is based on the premises that two percent of 20,000 parcels processed in one day has either less than five percent reflectivity, or higher than 200 percent reflectivity.

Productivity Gains of High Read Rate

The more parcels a dimensioner measures first time, the more efficient an operation will flow. Each parcel which has to be redirected or sent through the sorter again slows down operations and decreases throughput. A parcel which is not read the first time is typically sent through the sorter again for a second attempt. This means it does at least 1.5 rounds of the sorter. A parcel which is successfully read the first time is typically sorted out halfway through the sorter. An unread parcel will therefore use four times the sorter capacity than it would if it was read and measured correctly the first time.

3 High Throughput Weighing

While read rate is crucial to barcode reading and dimensioning performance, when it comes to weighing, throughput is key.

Throughput is important when considering the right load-cell technology to use. The higher the throughput, the less time there is to stabilize and weigh each package. Dynamic scales run at throughput rates of up to 250 parcels per minute. The longer the item, the faster the conveyor must move to maintain throughput. Using a shorter weighing section helps minimize conveyor speed while maintaining optimal throughput. Software can send a signal to a separation belt to ensure that spacing is sufficient to weigh one item at a time. A dual scale or triple scale will increase throughput without the need to increase speed.

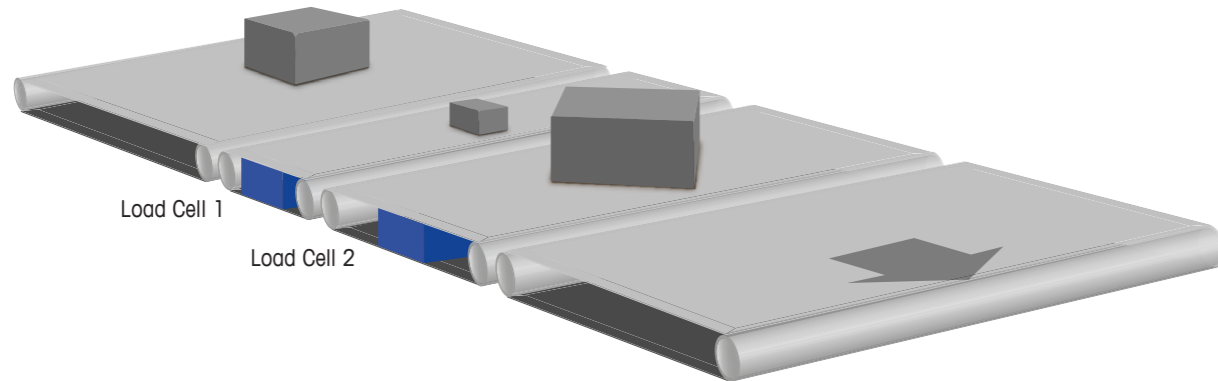

Increase Throughput by 30% with Two Weighing Belts

In a sorting environment, the parcels that need to be weighed come in all different shapes and sizes. The weighing belts need to be as long as the length of the longest parcel. However, having only a single long weighing can have a negative effect on system throughput due to the need to weigh smaller parcels too. A small item, although weighed quickly, still has to run the length of the scale belt until the next parcel can be weighed. This eventually slows down overall production and decreases sorter throughput. A dual scale with two weighing belts of different lengths offers a solution to this problem. Parcel length is detected using either a dimensioner or a photo eye. If the parcel approaching the scale is small, it is sent to the shorter scale belt to be weighed. If it is over a certain predefined length, it is sent to the longer belt. The longest parcels are weighed over both weighing belts. In a typical high speed parcel operation, a dual scale will increase throughput by approximately 30 percent.

Chapter 5 Site Planning

Getting the most out of your DWS system involves careful planning to optimize operational productivity. This chapter covers what to consider when automating processes for the first time and integrating a DWS into an existing automated facility.

When the time comes to develop a plan for the site of a system, it is important to consider not only how it fits in today but also how it will meet future needs. The typical lifespan of DWS equipment is five to seven years. Therefore, it is important to consider all details of site planning from the beginning.



Contents

- 1 Point of Data Capture
- 2 Integration into a Sorting System
- 3 First-time Automation
- 4 Replacing Existing Equipment
- 5 Site Conditions

1 Point of Data Capture

The earlier in the process you capture data, the better control you have. Typically, data is captured either at the service station or at the hub. New hand-held dimensioning and scanning devices offer the possibility to check a parcel or pallet at the point of pick-up so that data can be sent ahead and used for load planning. This also can be achieved by capturing data when a shipment arrives at its first stop, which typically is a service station. Because throughput often is lower at the service stations, it is possible to combine measurement with a relabeling process to increase sorting efficiency later down the line.

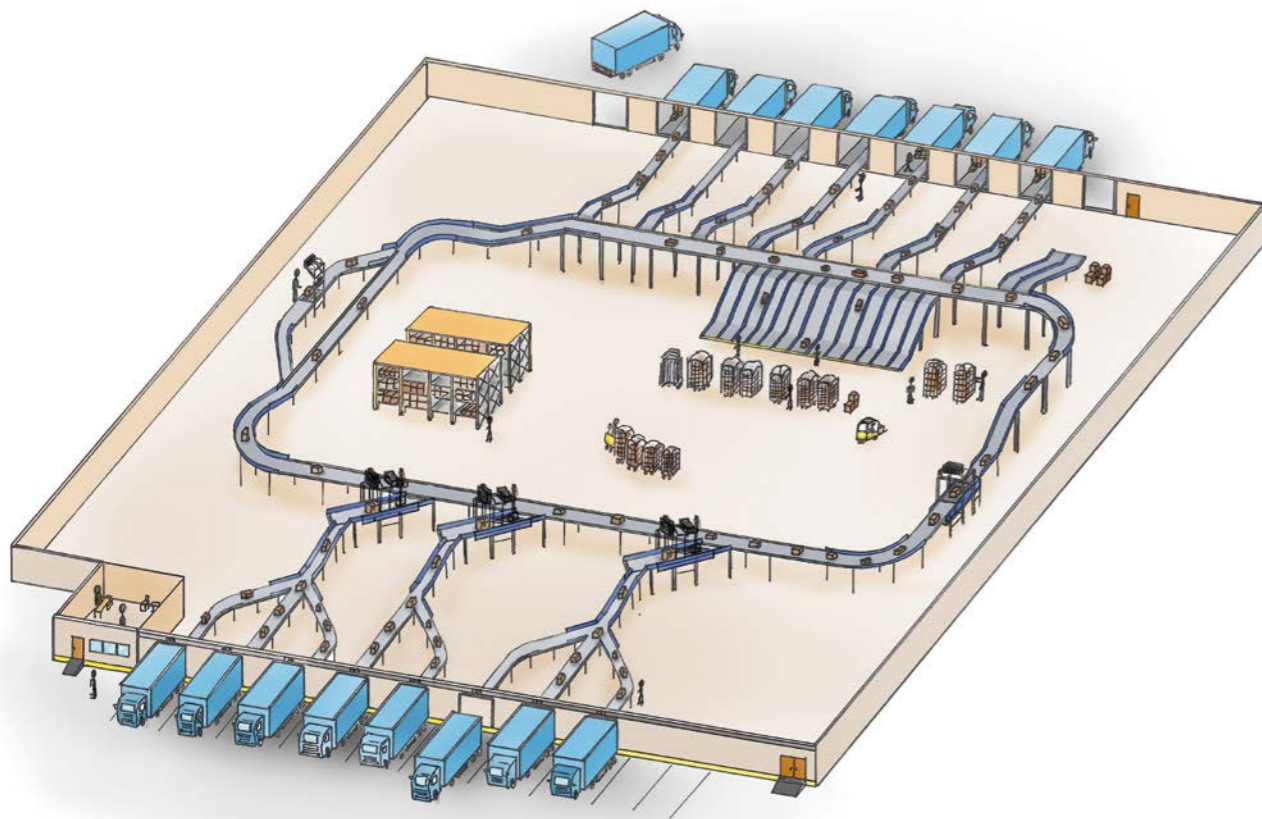

Throughout its journey, a shipment often has a long and bumpy journey. Because of this, it makes sense to capture data early on in the process, before any deformation takes place. DWS equipment can be supplied with cameras that take a photo of each item that is identified, weighed and measured. Images can be used for proof of content, condition and to provide a valuable customer-service tool when handling customer claims and disputes. In addition, images provide proof that the package or pallet was weighed and measured using a legal-for-trade-approved system.

If you intend to capture data at a hub, you have to be sure that everything will pass through the hub at some stage. It is typical of highly automated processes that data is captured at the hub. In this case, where everything is identified and measured in one place, it is important to have redundancy systems in place to limit the consequences of a system breaking down.

2 Integration into a Sorting System

When a DWS system is integrated into a sorting environment, it is important that the system communicates well with the sorting equipment. The package must be properly routed before being processed by the DWS, to ensure the best measurement conditions and to avoid situations such as multiple parcels on the scale or a jam.

What is required is two-way communication between the data-capture equipment and the sorter. There are different protocols used for this. Digital communication uses binary signals to talk between components. Industrial communication standards, such as Modbus, provide the quickest communication. There are various protocols based on Ethernet, which are probably the most common. It is important to check which protocols are supported by the sorter and to ensure that the software used by your DWS equipment is compatible.

Examples of required communication between a DWS system and sorter:

- An item has passed through the DWS
- Destination information
- An item is oversized or undersized
- An item is missing required information
- A barcode is damaged or unreadable
- Items are touching or traveling side-by-side

These are some of the standard communication signals. However, configurable application software can support customized data signals.

Conveyor Requirements

The quality and installation of the conveyor significantly influence the measurement accuracy and so it is important that a reputable supplier is used and that the quality and setup of the conveyors is compatible with the DWS equipment.

The following recommendations for conveyors apply:

- Conveyor width and position should not let parcels move outside the side limits of the measuring field
- Parcels must move undisturbed through the data-capture zone
- The conveyor must be straight with no curves
- The conveyor must be flat with no kinks of over 3 cm
- The conveyor must be sufficiently rigid to avoid sagging or swinging
- If the conveyor is on an incline, carefully consider whether the parcel might slip
- A shiny conveyor may reflect laser light and disturb the measurement

3 First-time Automation

Efficient Identification

The first step in implementing an automatic process for the first time is deciding how to identify the items you handle. Your decision will depend on how much information you want a label to carry. The most common method is barcode reading. Matrix labels contain more data but require camera scanning, which is often a larger investment. The leaner you want your process to be, the earlier in the process labeling should be done.

Operational Flow

To optimize operational flow, you need to consider throughput and the items to be conveyed. Manual intervention always means risk of disturbing automatic processes and misplacing data. The distance that an object must travel will determine what type of solution you need. If long conveyor lines are needed, automatic data-capture is most appropriate. If you operate in a small warehouse environment with goods moving over less distance, static measuring may be sufficient. Independent of flow, strive to capture data within the same area in as few operations as possible to keep track of data.

Necessary Data

The more data captured, the better control you have of your goods. However, not everything needs to be done in one step. A data-capture program can be implemented in stages. First, identify the specific challenges in your operation and which data is essential to ensure efficiency. If insufficient time for measurement is a key issue, then automatic dimensioning and identification will be a fundamental step in your process.

Reject Handling

On an automated line, there will be a certain number of no-reads and there are different ways of dealing with them. Your system can be configured to stop for operator intervention if a label is unreadable. However, this compromises throughput. A reject line can be set up to allow all unreadable items to be diverted and dealt with separately. If speed is your main priority, you may decide to let the no-reads pass through, but do all you can to make sure you have equipment that offers the highest possible read rate.

Layout and Infrastructure

Based on your chosen identification and data-capture method, supporting IT infrastructure should be selected. It is recommended that customer data be stored in a certified database. Dynamic systems can be slowed down by the slow response of a computer host system; make sure that you spend enough time and effort on building up an adequate IT resource.

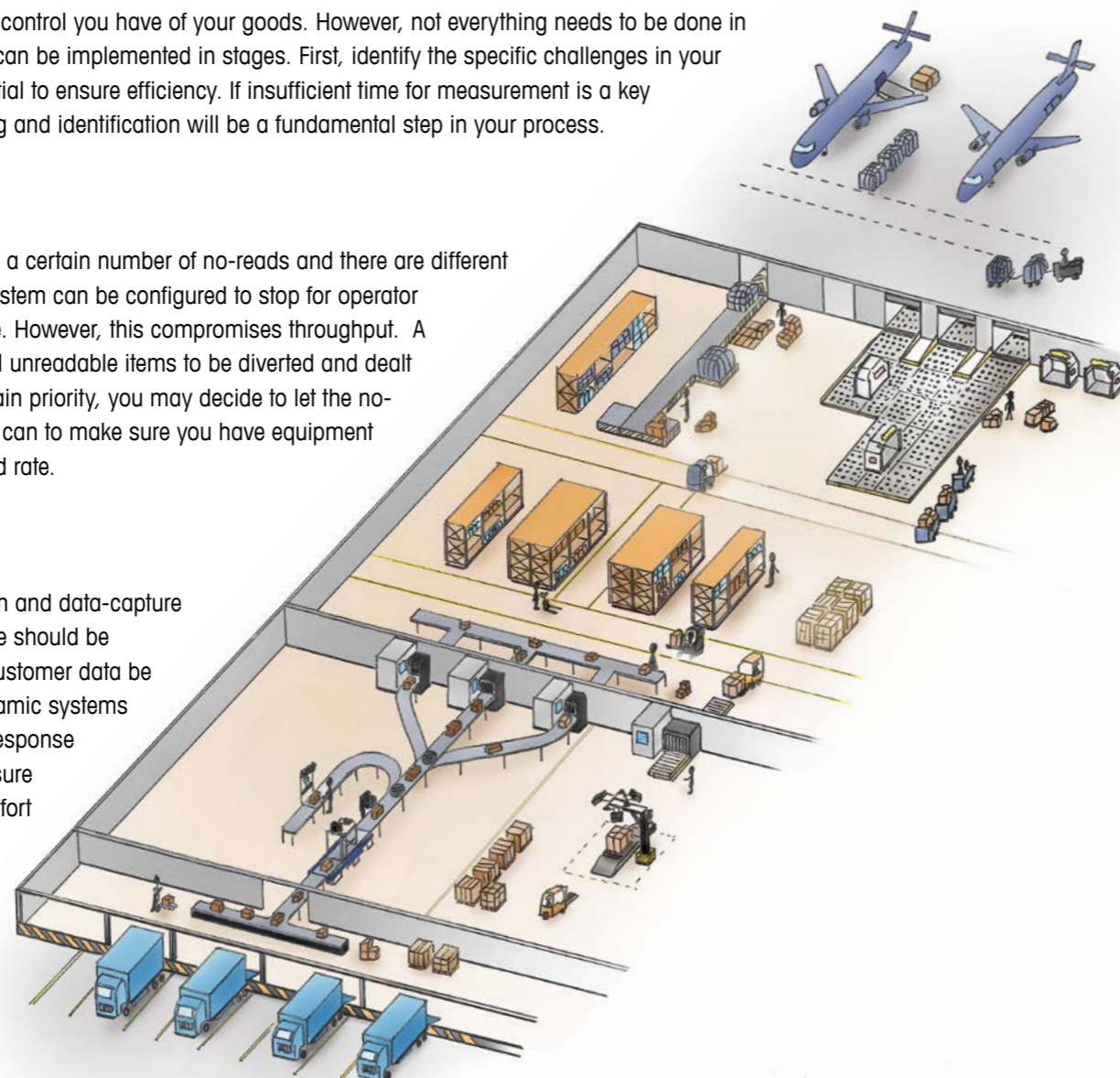

4 Replacement of Existing Equipment

Upgrading

When upgrading existing DWS equipment, it is important to evaluate the compatibility of old systems with new hardware. For simple upgrade, the new equipment should be compatible with old interfaces and hardware lines. Your supplier may offer upgrade kits that make it easy to replace old systems with new technology while maintaining use of components that don't need to be replaced.

Productivity Improvement

Advancements in dimensioning, weighing and scanning technology are continuously being made. Software is becoming smarter and more modular with the possibility for new, more powerful applications. When evaluating new equipment, it is important to consider what is newly available on the market and how new solutions could add value to your operation.

It can pay to invest in the future. During a retrofit project, consider future trends and the direction in which you see your business and its challenges heading. Think not only about what your operation looks like today, but also about what it might look like in three to five years. If you see, for example, that you are handling more and more irregular shapes, that parcels are getting bigger or that there is an increased demand for reading of 2D barcodes, it makes sense to evaluate a solution that will prepare you for the fruition of these trends.

Modular Software

Software modularity is an important aspect to consider. A system should be flexible enough to allow for upgrades and updates as technology or software become outdated. New value-add features are continuously being developed and so to continuously improve, it is essential that your DWS system's software is easily adaptable to future needs.

Advance Preparation

Contact prospective suppliers early to communicate the scope of your replacement project, define equipment specifications and order the required engineering support. When retrofitting a site, choose an experienced supplier who is aware of the frame conditions and can provide replacement products with minimum downtime.

5 Site Conditions

The reliability of a DWS system is dependent on certain environmental factors. When choosing a system, always take into account the workplace environment and the features of a system that will help to withstand problems caused by challenging conditions.

Temperature and Humidity

Devices should maintain precision in the temperature range found within a transport terminal. Dimensioners are approved for operation within a certain range. Outside this range, a device may give inaccurate results or cease to operate. Some load cells are not suited to handle high moisture and temperature fluctuations. Strain-gauge load cells that are not hermetically sealed can be compromised by external contaminants.

External Lighting

Many dimensioners use light-based technology, so external lighting can effect reliability of the device. Sunlight, truck lights as well as the bright terminal lighting may cause incorrect measurement. Dimensioning devices must be designed to tolerate a wide range of light extremes from sunlight to almost no light. There are no governmental certification requirements for this environmental factor. Vendors should provide test results that show their equipment will function under the appropriate light extremes.

Debris and Dust

Dust and dirt can be harmful to devices using focused lasers. Similarly, debris falling on and around the weighing section can offset the zero-setting on a scale. If debris builds up the scale, it will need to continually re-zero. Devices should have an appropriate design to withstand dust and dirt. It is good practice to keep a clean area around your DWS equipment.

Vibrations

Any vibration introduces “noise” or unwanted signals to a DWS system. To maintain the geometrical configuration of the DWS components, avoid placing the system on a mezzanine, next to trucks carrying heavy goods or on wooden surfaces. Other external devices that contain moving parts, such as conveyors, should be securely fastened to the floor or wall to avoid vibrations. High performance DWS equipment can automatically filter out some extraneous noise. However, for optimal performance, a DWS system should be isolated as much as possible from extraneous vibrations.

Electrical Noise

All electronic equipment gives off electromagnetic radiation, which can interfere with weighing and measuring devices. Radio Frequency Interference can be caused by cell phones, pagers and other machines. Devices can be certified to withstand the common electromagnetic radiation found in a transport terminal environment. Manufacturers of this type of equipment should document that they have the correct certifications.

Chapter 6 Project Management

Investing in new technology needn't be daunting. Whether your operation calls for fully automated, semi-automated or static measuring, choose an experienced supplier that can advise and support you from initial consultation to installation.

No two businesses are the same and each transport and logistics application has its own special requirements. Modular solutions allow for customization to meet individual operational needs. Close cooperation between you and your supplier will ensure that the solution you choose is best for your unique operational requirements.



Contents

- 1 Project Support
- 2 Customization

1 Project Support

Before embarking on a project to implement new DWS technology, assemble a project team. This will include members of your own internal team and industry experts from the supplier's organization. Involve all prospects and contact prospective suppliers early. Close cooperation between the internal project team, the DWS supplier and the system integrator will contribute to a successful project.

- Internal project team**
 The people within your company who handle facilities, operations, revenue-recovery programs, computer systems and finance.
- DWS Supplier**
 Prospective suppliers can advise you on the project-management services they offer and assess the need for customization. DWS buyers typically narrow the number of prospective suppliers down to two or three. At that point, it can be beneficial to ask questions about maintenance, service and total cost of ownership.
- System Integrator**
 Large projects in which many products are to be installed at once may be conducted via a system integrator.

Your supplier will help you to define the different phases of a project. This will start with clearly laying out the objectives with analysis of business needs and short and long-term goals. The costs and benefits of the project should be outlined and equipment contract and lead-times carefully planned.

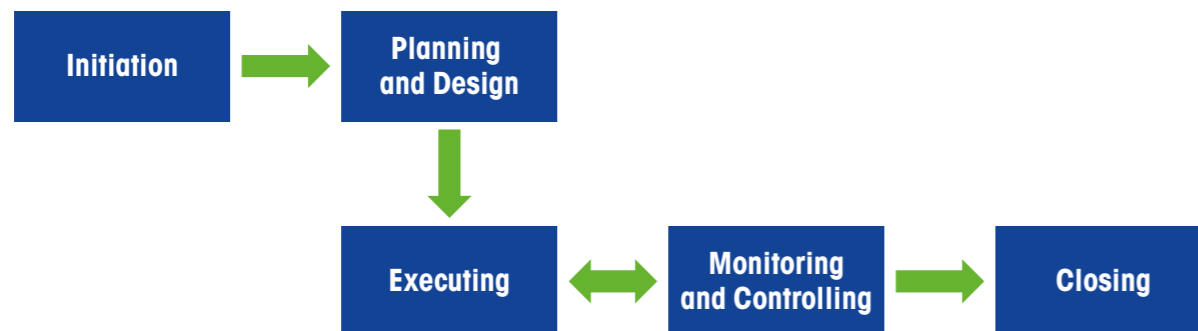

Project Phase	Activities
Initiation	<ul style="list-style-type: none"> • Analysis of business needs • Review of current operation • Definition of equipment and contract requirements • Overview of costs and benefits
Planning & Design	<ul style="list-style-type: none"> • Define project team and communication plan • Define deliverables and timeline • Schedule activities and plan resources • Analyze risk
Execution	<ul style="list-style-type: none"> • Coordination of people and equipment • Installation • Testing and training
Monitoring & Controlling	<ul style="list-style-type: none"> • Supervision of project execution • Evaluation of project according to cost and expectations • Implementation of corrective actions where necessary
Project Close	<ul style="list-style-type: none"> • Site acceptance test • Commence day-to-day operation of equipment

Cross-Border Project Management

The transport and logistics business is global in its nature and often, parcel express companies work on cross-border implementation of DWS equipment. Standardization is important in order to achieve consistent results and effective communication across systems and business units.

When managing a cross-border DWS implementation project, consider the following:

- Where the purchase will be made, locally or centrally
- Where the installations are to take place
- Local product finishing requirements
- Service requirements and service network of the supplier
- Project logistics, including delivery dates, transportation and customs clearance
- Local language documentation
- International and national Weights and Measures requirements
- Payment terms and conditions

Companies that require global consistency should work with a supplier who has a globally standardized product offering and a global network with the ability to manage a project across borders.

2 Customization

Because every operation is different, some customization may be required for smooth integration into an existing facility. The most common customizations are related to host communication and/or barcode validation.

Host Communication Customization

Customization of the host communication is required when a company's existing systems have a non-standard communication protocol. These include, but are not limited to:

- TCP/IP
- Web services
- Remote database stored procedure calls
- FTP transfer

In case the DWS supplier does not support the protocols used, the buyer should submit a specification document detailing what is required and request a customization.

Barcode Validation Customization

Another typical customization request is related to barcode validation. Commands can be set up to instruct the system to handle certain barcodes in different ways. For example, it can pick out specific information related to destination, customer profile, object type and instruct the sorter to handle an item with that barcode in a certain way.

When requesting a new barcode validation logic, it is important to provide the DWS supplier with specific information about the type of information required from the barcodes and what to do with that information.

Validation is achieved using one or more of the following criteria:

- Specific fixed characters
- Check digit rules
- Barcode length
- Code type

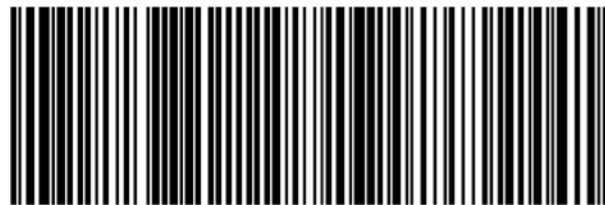

(01)07612345000121(10)123ABC-3

Chapter 7 Data Security & Safety

A DWS system should have the necessary features to guarantee that data cannot be tampered with. Alibi storage ensures that the data generated by the system can be trusted and used for invoicing.

When data is used for invoicing, it is imperative that it is secure. Even more important is the safety of operators using the equipment. DWS systems should be designed to ensure proper protection of both data captured and the people using the equipment.



Contents

-
- 1 Alibi Storage

 - 2 Security Features

 - 3 Health and Safety

1 Alibi Storage

Once merged, data captured using the different components of a DWS system must be stored in an alibi database. Alibi memory is internal storage in which legally relevant measuring results are to be stored. The data is protected against unwanted data modifications using checksums that detect errors that may have occurred during data transmission or storage. The number of days of storage is usually configurable, but data must be kept for a minimum of 90 days for legal-for-trade applications.

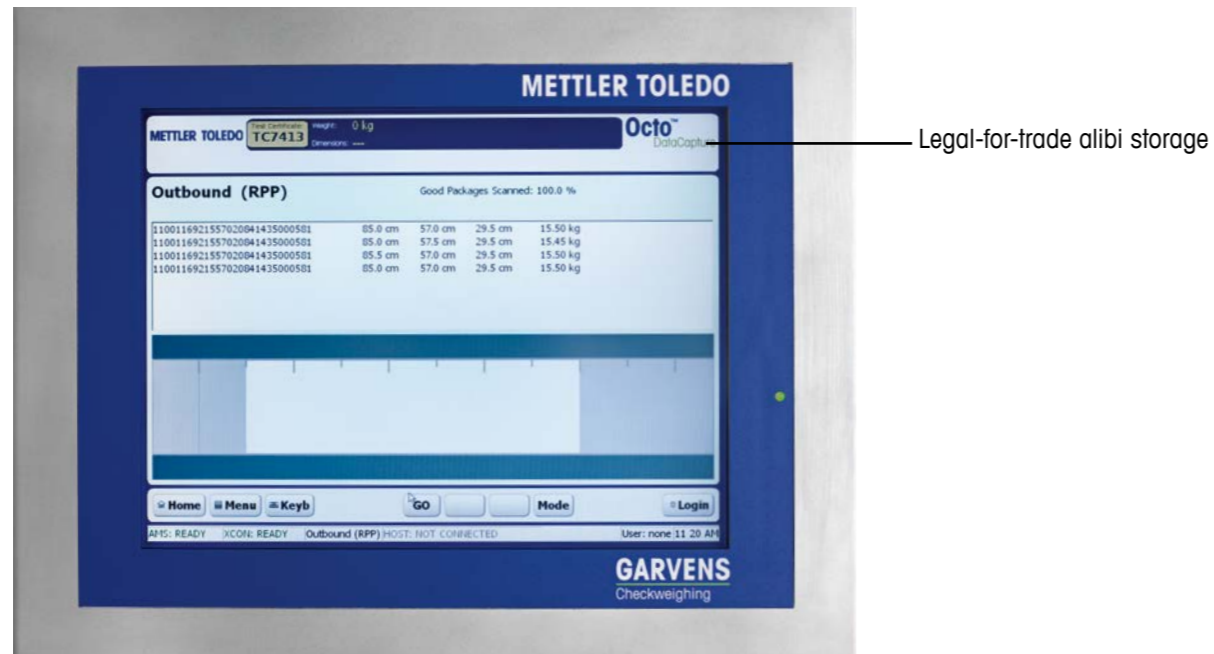

2 Security Features

It is important to know that the information generated by your system can be trusted. A DWS system should have the necessary features to guarantee that data cannot be breached by software, viruses or unauthorized persons. Below are two of the features to look for when evaluating the security of your dimensioning and weighing equipment.

Built-In Firewall

Some systems come with a built-in firewall, which ensures that only authorized personnel and devices have access to the data captured.

Operating Systems and Virus Protection

Linux-based operating systems are resistant to all known viruses. Neither viruses nor virus-protection software can change the programs or their installed files. When using a Windows-based operating system, it is important to utilize anti-virus software to reduce the risk of viruses and attacks that can alter data and affect the reliability of your system. Windows Embedded versions running on read-only flash memory do not require virus software.

3 Health and Safety

User health and safety is an important consideration. Design and build of DWS systems should be certified in accordance with statutory regulations and standards in force at the time of sale. For example, CE marking in Europe or third-party certifications, such as UL/cUL in North America, in relation to applicable machinery safety standards will minimize the risk of an employee being hurt.

Your DWS system should match the safety standards implemented at your plant. Pinch points should be minimized and guarded. An emergency stop may be critical. Some systems come equipped with emergency stop devices as a standard feature, others are an option and some are linked to the emergency stop of a conveyor or sorter. Consider inserting emergency stop functions along the entire line so that the line can be stopped at any location.

Operator Training

The operators using the equipment should have read the operating manual with close attention to the general rules for the prevention of accidents and all binding rules or laws for the prevention of accidents and protection of the environment. The person using the system must not have long hair, wear loosely fitted clothing or jewelry or the person runs the risk of being caught by moving parts and pulled into the machine/system, which could cause severe injuries.

For the sake of safety, all warning signs and symbols on the machine/system must be kept in good condition and must be clearly visible.

If there is a fault or a change in the behavior or performance of the machine/system that may affect its safety, the machine/system must be stopped immediately and the responsible person/supervisor be informed.

Conveyor Belt Safety

The major safety concerns of operating a DWS are associated with the conveyor belts. Being trapped in a conveyor system will cause serious injury and all precautions must be taken to minimize the risk. Before operating the belt for the first time on a shift, the operator must make sure:

- The loading/unloading areas are free of slip and trip hazards
- Emergency stops and all other controls are functioning properly
- No one is working under the conveyor belt
- No one is working within the fall zone beside the conveyor belt
- The conveyor belt has no tears or material caught between the belt and the rollers

Always consult the safety precaution document provided with equipment before operation.

Chapter 8

Installation and Certification

DWS equipment must be correctly installed, operating personal correctly trained and performance verification carried out in a professional manner.

Once the site is prepared, your DWS system can be installed. This can mostly be organized by your supplier, but the customer needs to be closely involved to provide onsite support. Knowing what to expect can help you to develop a reasonable timeline for your installation.

**Contents**

-
- 1 Delivery and Installation

 - 2 Testing and Calibration

 - 3 Approvals and Certification

1 Delivery and Installation

Installation

Installation instructions should be consulted prior to and during installation. This will ensure that the best possible performance is obtained from the system and the risk of environmental influences during operation is minimized.

Loading and Transport

When loading or transporting weighing and measuring equipment, use lifting and transportation devices with a sufficient working load. In addition, always read, understand and follow all written instructions from the supplier regarding unpacking and movement of the equipment. Always secure the weighing section when transporting a scale to a new location. Before moving a scale, always disconnect it completely from all external power sources, compressed air supply and data connection cables. Before restarting, verify that all cables and supplies are securely connected.

Equipment Access

The DWS system should be accompanied by clear documentation and drawings that illustrate the principal electrical and mechanical interfaces and access locations for maintenance and operation. Equipment should be positioned in such a way to give clear access to the user interface and control cabinet for ease of servicing and operation. It should also be accessible from all sides for ease of inspection and cleaning. The installation should be capable of being easily cleaned and maintained without the need for dismantling during routine operations.

Load-cell Handling

The load cell is a precision measuring instrument and must be handled with the utmost care. Damage from shock loading, excessive pressure or objects falling on the weighing section must be avoided. Sitting, stepping or placing tools on the weighing section must be absolutely avoided.

Accuracy

It is vital during commissioning to ensure that the DWS system fulfills the specified accuracy requirements. Accuracy, linearity, repeatability and re-zeroing should always be checked by your supplier prior to delivery and also on-site in your production environment.

Training

Operators must be trained to a basic level to operate, care for and maintain the equipment. The minimum requirements before starting operation should be setup, operation modes and immediate action to be taken in the case of unplanned stops.

2 Testing and Calibration

Calibration

When measurements are used for invoicing, equipment performance must be tested and documented to comply with regulations. Every measuring solution should be properly calibrated and documented for proof of performance so that you can be certain your processes meet requirements. Proper calibration will maximize system reliability, reduce the risk of error and give consistent results.

A calibration agreement from your supplier will give on-going confidence in equipment. Discuss calibration and maintenance service plans to protect your company from audit risk and other liability issues that could arise as a result of out-of-specification equipment.

Site Acceptance

After installation, the performance of any DWS system should be verified. It is recommended that performance verifications are carried out by the supplier service technicians. A service technician will always have the tools and equipment required to carry out this task and make adjustments where necessary. The test procedure should test the following attributes of the system:

- Modes of Operation
- Barcode reading
- Dimensioning
- Weighing
- Emergency Stop
- Alibi Memory
- Host Communication

Documentation

All findings and results of the site acceptance test should be recorded by the person carrying out the assessment. Certified equipment should be supplied with a Certificate of Conformance to prove that the equipment is operating according to Weights-and-Measures-approved and legal-for-trade standards.

3 Approvals and Certification

Legal-for-Trade Applications

If your DWS system is to be used for invoicing, your application needs to be "legal for trade." Legal-for-trade applications most often are required to meet a set of federal, local and/or regional requirements. This can include criteria for specifications, operational principles and calibration intervals intended to protect business transactions from scale and dimensioner inaccuracy or fraud.

Metrology Authorities

Metrology is defined as, "the scientific study of measurement." Most locations look to a recognized metrology authority for measurement standards to ensure equality in business transactions. When it comes to dimensioning and weighing equipment, those authorities will provide certifications for systems and components that meet their performance requirements.

OIML

In many European and Asian countries, the International Organization of Legal Metrology (OIML) provides the standards that measuring devices must meet for commercial applications. That includes the dimensioning and weighing components of a DWS system.

OIML regularly updates its series of recommendations, guides and other reports and documents. Devices that comply with OIML specifications will carry an OIML classification. For DWS components, such as the dimensioners and load cells, this will define tolerances for their accuracy and capacity, which are verified by standardized testing.

NIST & NTEP

In the United States, regulations are defined by the **National Institute of Standards and Technology** (NIST) Handbook 44, "Specifications, Tolerances, and Other Technical Requirements for Weighing and Measuring Devices." It is most often referred to as Handbook 44, or simply H-44, and is revised annually. H-44 provides the federal specifications for the performance of weighing and measuring equipment found in a DWS. It also covers the user requirements or tasks that the user and owner are to do.

Devices that are intended for commercial applications will carry the **National Type Evaluation Program** (NTEP) certification issued by the National Conference on Weights and Measures (NCWM). This signifies that the product or component has been tested to conform to the NIST H-44 requirements.

MID

The **European Measuring Instruments Directive** (MID) is a directive that seeks to harmonize legal metrology across the member states of the EU. The MID was announced by the DIRECTIVE 2004/22/EC OF THE EUROPEAN PARLIAMENT AND OF THE COUNCIL and came into effect in 2006.

It is valid for all EU member and European Free Trade Association countries as well as Liechtenstein, Iceland, Norway and Switzerland.

This European Directive describes in detail the processes and responsibilities for 10 types of measuring instruments, including dimensioners and dynamic scales during their production and commissioning.

Prior to the MID, the national legal verification authorities were responsible for determining and confirming whether weighing and measuring equipment complied with national error limits for initial legal verification. Under the MID, it is now the supplier who is responsible for determining and confirming that the checkweigher complies with these error limits under production conditions with a conformity assessment. Once the conformity assessment has been successfully completed, the CE declaration can be provided.

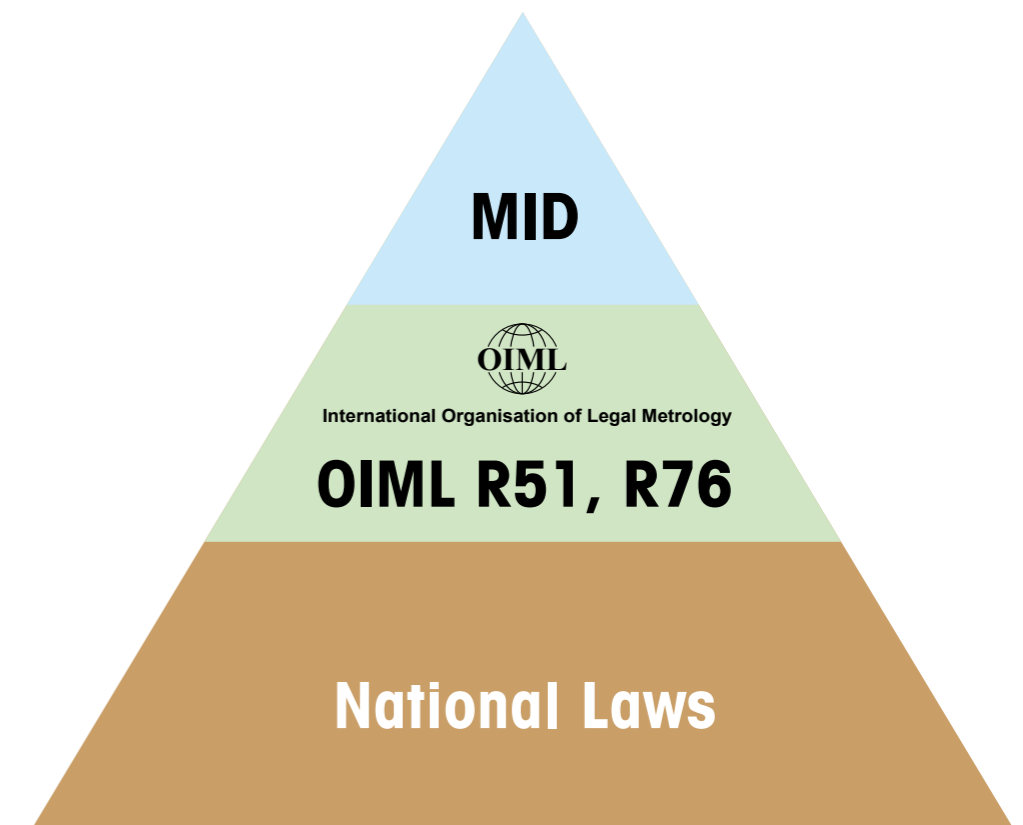

Other Regions

Many other federal and provincial weights and measures authorities around the world acknowledge the standards of the aforementioned organizations. Many will accept devices carrying certification from one of those agencies. Your regional weights and measures authority can provide further details regarding the certifications it accepts for commercial weighing and measuring equipment.

Metrological Regulatory Agencies

While the metrology agency may provide certifications for new product designs, ongoing enforcement of measurement standards is left to local metrological regulatory agency, often known as a department of weights and measurement (W&M).

You will need to contact your local W&M department, as representatives will often need to perform inspections, tests, calibration and certification before your new system can be used. It can be best to contact them early in the process to ensure you are familiar with their requirements. Inform them that you will be installing a DWS system and ask for all regulations pertaining to the installation and operation of truck scales in your state or province. You will likely be in contact with them periodically throughout the life of the system, as they may need to perform inspections and tests to recertify the equipment.

Chapter 9

Maintenance, Service & Warranty

Once a system is installed, operational and certified for use, you may be ready to consider your project a success. However, taking the time to develop a scheduled maintenance program while the system is still new can keep it performing optimally and increase its longevity.

When first making the decision to invest in a DWS system, it is also the perfect time to utilize the expertise of your supplier to discuss plans for service and repairs – both planned and unplanned. It pays to think about how you will handle service and repairs before you actually need them.

**Contents**

-
- 1 Scheduled Tests and Maintenance

 - 2 Preventative Maintenance and Inspection

 - 3 Emergency Service

 - 4 Warranties

1 Scheduled Tests and Inspection

Typically, a DWS requires little maintenance by operators or site supervisors, but it is wise to have a regular check-up by a trained service technician to keep the system calibrated and running correctly. A maintenance service agreement should be considered when first evaluating the purchase of new equipment and should cover the following:

- Phone response time
- Hours of coverage
- Remote troubleshooting and assistance
- On-site troubleshooting and repair
- Preventive maintenance
- Spare parts

A spare parts logistics plan is essential for maintaining uptime on DWS equipment. In highly automated sorting environments with high throughput, it is recommended to budget for redundancy systems so that if one breaks down there is no downtime while service is requested.

2 Preventative Maintenance & Inspection

It is advisable to regularly check the performance of your DWS equipment. This can be done simply by running a test box with known dimensions and weight through the system to check that the reported weight and measurement data is correct.

In addition, it is important to regularly check that:

- Barcode-reader windows are clean
- Photoeyes are clean and positioned correctly
- Emergency stop buttons are working correctly
- Safety guards and instructions are in position
- Communication cables have a good connection
- There is no tape, cardboard or paper that can clog up conveyors

3 Emergency Service

If your DWS system goes down unexpectedly, your business could be losing money with every hour that you have to wait for repairs. Ideally, you want a service provider with the right tools, equipment, knowledge and replacement parts to fix a problem in a single visit.

Pose the following questions to your potential supplier:

- What is the availability of spare parts?
- What is the travel time for their location to your site?
- What is needed to determine what is wrong with a system? What tests does the technician perform?
- How long does it take to replace a component?
- Is after-hours service available?
- How fast can the manufacturer get parts to the local service organization?
- What equipment is available from the local organization?
- Is it possible to perform remote diagnostics rather?

4 Warranties

Your DWS system should come with a manufacturer's warranty. As a customer, this is an area in which you should take time to evaluate options, as warranties can vary considerably. Some manufacturers offer a very limited standard warranty with expanded warranty coverage at an added cost. Take the time to actually read the fine print of the warranty and analyze the following categories:

What does the warranty cover?

Determine the specific level and duration of coverage for the following:

- Types of components covered
- Types of failures covered
- Replacement parts
- On-site labor
- Travel costs for technicians

There may be certain components that are excluded from the warranty, or that may be covered under their own separate warranty, such as accessories to the system.

How responsive is the manufacturer to warranty coverage?

Does the manufacturer of your DWS have a local sales/service entity or distributor? If not, someone may need to be dispatched from another location. It may be up to you to consider the "what ifs" and determine how responsive you think a company will be in an emergency situation.

All DWS systems will eventually need service. Most owners want to ensure they have a reliable partner for service and a plan to maintain continued high performance. The time it takes to develop this plan can be well worth the effort in the resulting peace of mind.

METTLER TOLEDO

Total Solutions Provider

METTLER TOLEDO has the broadest range of dimensioning, weighing and scanning solutions, and works with the biggest names in the industry. We will map your processes and make a proposal for which DWS system best meets your data capture needs. By analyzing operational processes and discussing individual challenges, we can put together a plan to ensure you achieve your goals for revenue recovery and productivity..

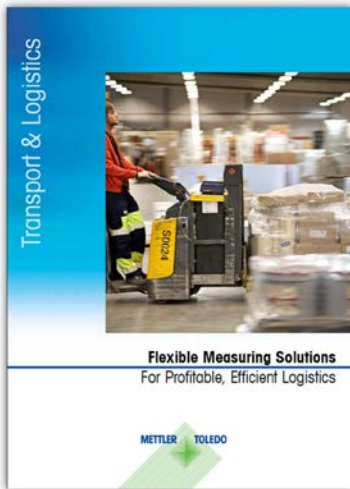

Flexible Measuring Solutions for Profitable, Efficient Logistics

Transport & Logistics Competency Brochure
► www.mt.com/logistics-competency

www.mt.com/logistics-competency

For more information

METTLER TOLEDO Group
Industrial Division
Local contact: www.mt.com/contacts

Subject to technical changes
©08/2021 METTLER TOLEDO. All rights reserved
Document No. 30133019 B
MarCom Industrial