

Operating instructions

METTLER TOLEDO MultiRange
Floor scales/Pit scales

METTLER TOLEDO

KC300/KCS300
KC600/KCS600
KD600/KD1500
KE1500/KE3000
KES1500/KES3000

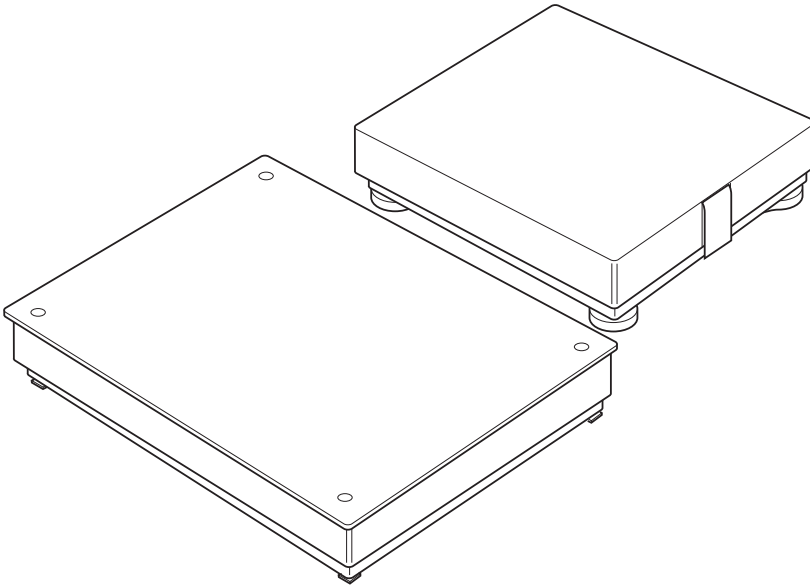

www.mt.com/support

Contents

1	General information	4
2	Safety precautions	4
3	Equipotential bonding	6
4	Operating limits	7
5	Cleaning the weighing platform	9
5.1	Removing the load plate at KC... and KCS... weighing platforms	9
5.2	Opening and closing the foldable weighing platforms K...sk	10
5.3	Notes on cleaning	12
5.4	Subsequent treatment	13
5.5	Cleaning the measuring cell	14
6	Standard accessories	15
7	Technical data of the measuring cell	18
8	Disposal	18

1 General information

The weighing platform is part of a modular system. The associated components, such as terminals, application pacs and the extensive range of accessories, allow you to assemble a weighing system ideally tailored to the needs of your operation.

2 Safety precautions

- ▲ The explosion-protected weighing platform is approved for operation in Zones 2 (gases) and 22 (dusts) hazardous areas. There is an increased danger of injuries and damage when using the weighing platform in hazardous areas! Exercise particular care when using in such areas. The rules for behaviour are based on the concept of "Safe Distribution" established by METTLER TOLEDO.
- ▲ Explosion-protected weighing platforms may be used in hazardous areas of Zones 2 and 22 only in conjunction with weighing terminals that have the appropriate approval and interface specification.
- ▲ The connection cable may not be separated from the weighing terminal while it is energised.
- ▲ Tighten the knurled nut of the IDNet connection cable with 10 Nm of force.

Selecting installation location

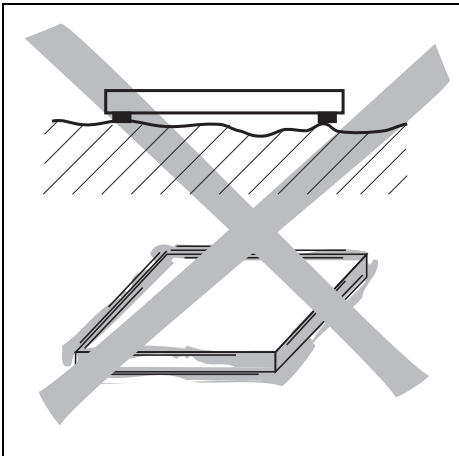

- ▲ The foundation must be capable of safely support the weight of the weighing platform at its support points when it carries the maximum load. At the same time, it should be so stable that no vibrations occur during weighing operations. These requirements also apply when the weighing platform is integrated in conveying systems and the like.
- ▲ Ensure that there are no vibrations from machines near the installation site.
- ▲ Ensure that there are no drafts at the installation site.
- ▲ The underground has to be even.

Ambient conditions

- ▲ Use powder-coated/enamelled weighing platforms only in a dry environment.
- ▲ In a damp environment, in wet operation or when working with chemicals: use stainless-steel or hot-galvanised weighing platforms.

Operation and Maintenance

- ▲ Ensure that the personnel has been instructed correspondingly before working on the weighing platforms with foldable load plate and has read and understood these operating instructions.
- ▲ Ensure that the weighing platforms with foldable load plate are only operated within a temperature range of -10 °C to $+40\text{ °C}$.
- ▲ Ensure that mounting and maintenance of the weighing platform, in particular of the gas pressure spring, is carried out exclusively by an authorised METTLER TOLEDO service technician.

3 Equipotential bonding

The equipotential bonding must be installed by a professional electrician when using the weighing platform in Zones 2 and 22. METTLER TOLEDO Service only has a monitoring and consulting function here.

- Connect equipotential bonding (PA) of all devices (weighing platform and service terminal) in accordance with the country-specific regulations and standards. In the process, make sure that all device housings are connected to the same potential via the PA terminals.

Equipotential bonding with KC..., KCS...

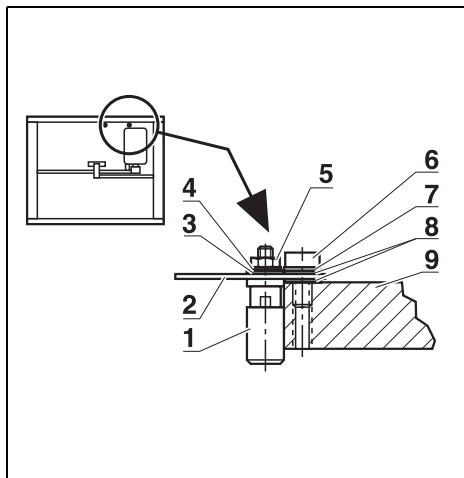

- (1) Equipotential bonding clamp
- (2) Potential plate weighing platform
- (3) Serrated lock washer 4.3 DIN 6798
- (4) Washer 4.3 DIN 125
- (5) Hexagonal lock nut M4 DIN 934
- (6) Fillister head screw M5x12 DIN 912
- (7) Washer 5.3 DIN 125
- (8) Serrated lock washer 5.3 DIN 6798
- (9) Frame bracket, thread M5 is present

Mounting material is included in weighing terminals IND560 with option D-IND560xx, IND690xx and IND780 with option D-IND780xx.

Equipotential bonding with KD..., KE..., KES...

- Secure equipotential bonding clamp to a suitable area of the base frame.

Mounting materials

Mounting material is included in weighing terminals IND560 with option D-IND560xx, IND690xx and IND780 with option D-IND780xx.

4 Operating limits

The weighing platform has such a rugged design that no damage should result if the maximum weighing capacity is occasionally exceeded.

The static load-bearing capacity, i.e. the maximum permissible load, is dependent on the type of loading (positions A – C).

Maximum permissible load

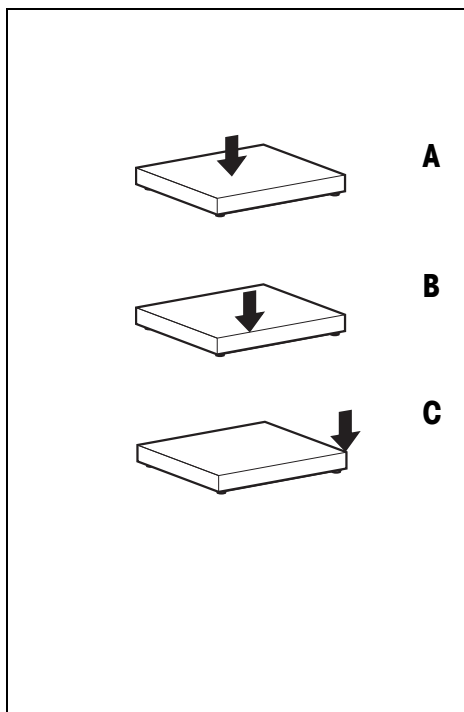

	KC300 KCS300	KC600 KCS600
A	500 kg	1000 kg
B	330 kg	650 kg
C	165 kg	330 kg

	KD600 KD1500	KE1500 KE3000 KES1500 KES3000
A	3500 kg	4500 kg
B	2300 kg	3000 kg
C	1150 kg	1500 kg

A with central load

B with side load

C with one-sided corner load

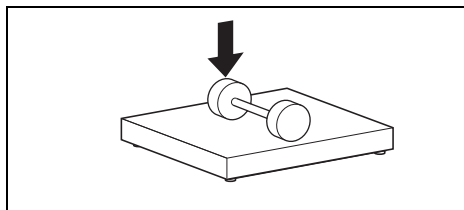

▲ When travelling across recessed weighing platforms with lift trucks, ensure that the axle load does not exceed the maximum side load (see above).

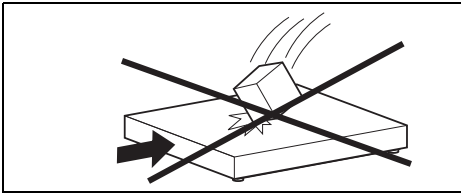

▲ Falling loads, shocks and lateral impacts must be avoided.



▲ Avoid abrasive and wear processes.

5 Cleaning the weighing platform

Maintenance of the weighing platform is limited to regular cleaning and subsequent oiling. The procedure depends both on the type of surface (powder-coated/enamelled or stainless steel) and on the environmental conditions prevailing at the installation location. Remove dirt and deposits at regular intervals from the outside and inside of the weighing platform.

5.1 Removing the load plate at KC... and KCS... weighing platforms

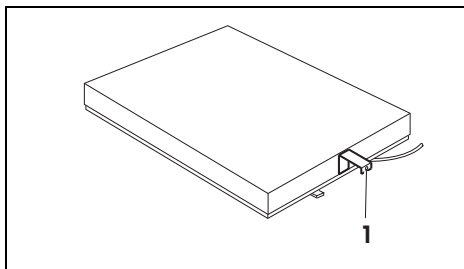

- Remove the load plate by pivoting the two side handles (1) outward.

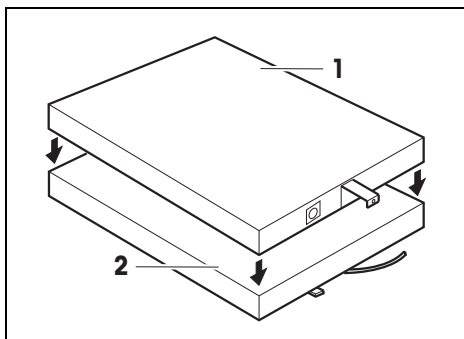

- Replace the load plate (1) so that the symbol O is located above the level indicator. Make sure that the load supports (2) in the corners of the weighing platform are vertical.

5.2 Opening and closing the foldable weighing platforms K...sk



DANGER

Danger of injury through shutting load plate at KE...sk- und KES...sk weighing platforms!

- ▲ **Only** open and close the load plate with the supplied tools!
- ▲ **Never** work under an opened unsecured load plate!



WARNING

Danger of crushing

- ▲ Only instructed personnel may open/close the weighing platforms with foldable load plate.
- ▲ Ensure that there are no persons in the danger area or under the opened load plate.
- ▲ Operation only from the right-hand side.

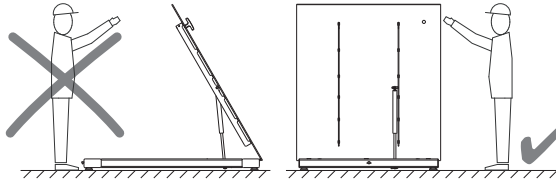

WARNING

At K...sk weighing platforms even slight damage, corrosion or paint residues on the piston rod lead to failure of the gas pressure springs!

- ▲ Protect gas pressure springs against soiling and damage.
- ▲ Have soiled or damaged gas pressure springs replaced immediately by the METTLER TOLEDO Service. Use only the spare parts specified by METTLER TOLEDO.
- ▲ Do not oil the piston rods of the gas pressure springs.

Opening the weighing terminal

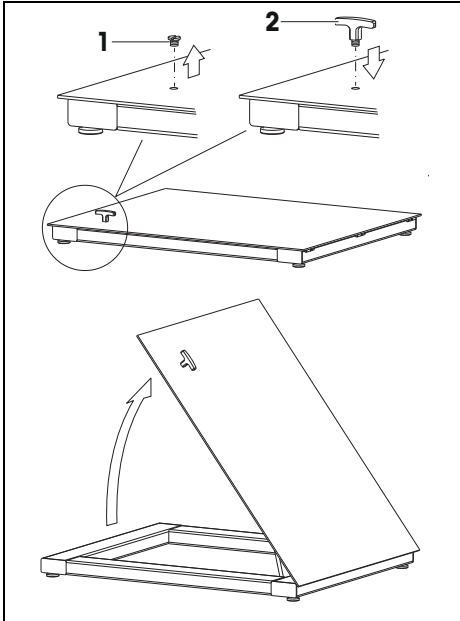

1. Remove weighing goods or superstructure from the load plate.
2. Use a screwdriver to screw out the cover screw (1).
3. Turn the handle (2) clockwise into the exposed thread until it stops.
4. Position yourself next to the weighing platform.
5. Pull the load plate up using the handle.
6. Ensure that the gas pressure spring has extended completely.

Closing the weighing platform

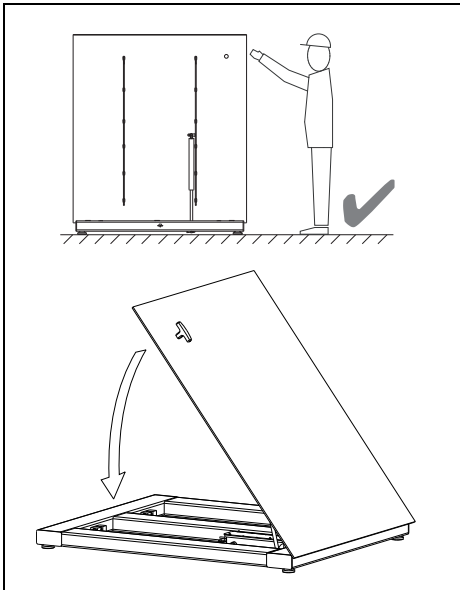

1. Position yourself next to the weighing platform.
2. Press the load plate down using the handle.
3. Ensure that the load plate latches in and lies evenly on the load frame.
4. Turn out the handle counter-clockwise.
5. Screw the cover screw into the load plate.

5.3 Notes on cleaning



CAUTION

Incorrect use of cleaning agents may cause damage to the weighing platform!

- ▲ Use only such cleaning agents that do not act on the plastics used in the weighing platform.
- ▲ Only use disinfectants and cleaning agents in accordance with the manufacturer's instructions.
- ▲ Do not use highly acidic, highly alkaline or highly chlorinated cleaning agents. Avoid substances with a high or low pH value since increased danger of corrosion otherwise exists.
- ▲ Be particularly careful when cleaning the measuring cell.

Powder-coated/enamelled version, dry environment

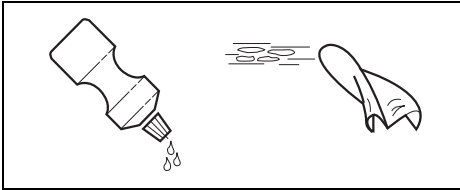

- Wipe with a damp cloth.
- Use household cleaning agents.

Stainless-steel and hot-galvanised version

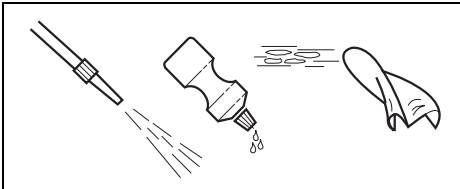

- Wipe with a damp cloth.
- Water jet up to 60 °C.
- Use household cleaning agents.

Corrosive environment

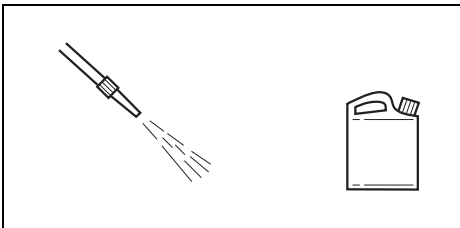

- Water jet up to 60 °C.
- Remove corrosive substances at regular intervals.
- Only use disinfectants and cleaning agents in accordance with the manufacturer's specifications and instructions.

Cleaning a recessed weighing platform

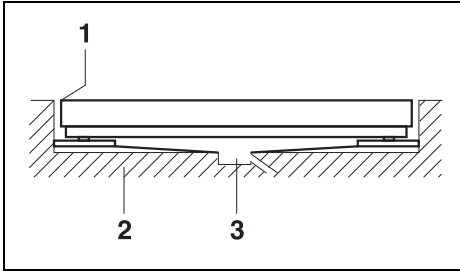

- Ensure gap (1) between weighing platform and pit frame is always kept clear.
- Remove larger dirt deposits at pit bottom (2) at regular intervals.
- Check pit drainage channel (3) for blockage at regular intervals.

5.4 Subsequent treatment

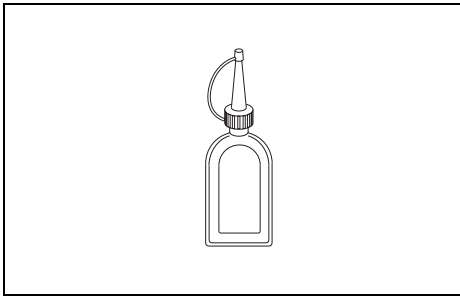

Carry out the following subsequent treatment in order to protect the weighing platform:

- Rinse the weighing platform with clear water and remove cleaning agent completely.
- Dry off the weighing platform with a lint-free cloth.
- Treat the inside and outside of the weighing platform with an oil suitable for foodstuffs.

Particular subsequent treatment at foldable weighing platforms K...sk



WARNING

Failure of the gas pressure springs!

- ▲ Do not oil the piston rods of the gas compression springs.

Special treatment for scales installed in the floor or a pit

- Treat all the moving parts, such as flexible bearings, knife edges and bearings, thoroughly with an oil suitable for foodstuffs after cleaning them.

5.5 Cleaning the measuring cell

The load plate has to be removed or the weighing platform opened respectively in order to clean the measuring cell.

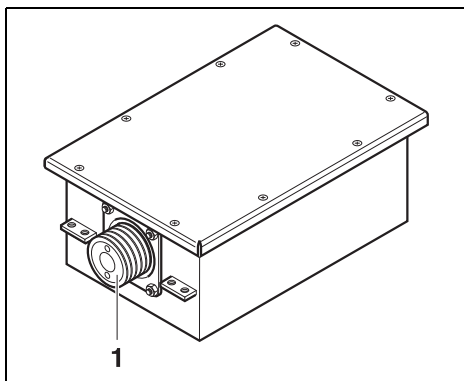

CAUTION

The measuring cell can be damaged!

▲ During cleaning work, never touch, direct an airflow against or spray the rubber diaphragm (1) of the measuring cell.

→ Blow out dirt or flush out with a medium-power water jet.

6 Standard accessories

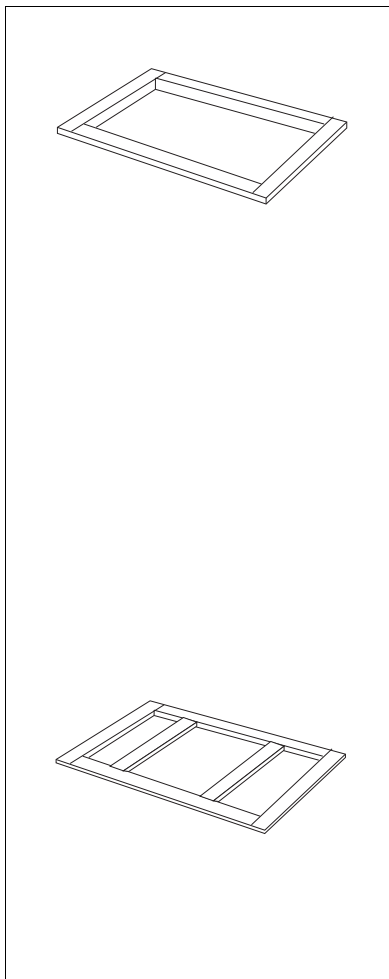

Order No.

Pit frame

Installation kit incl. fastening materials

for KC300, KC600	
hot-galvanised	00 503 635
stainless steel	00 503 636
for KCS300, KCS60	
hot-galvanised	00 504 550
stainless steel	00 504 551
for KD... , hot-galvanised	00 504 077
for KD... , stainless steel	00 506 399
for KE... , hot-galvanised	00 504 079
for KE... , stainless steel	00 506 400
for KES... , hot-galvanised	00 504 512
for KES... , stainless steel	00 506 401
for KE...sk, stainless steel	00 505 270
for KES...sk, stainless steel	22 007 261

Pit frame with cleaning recess on both sides

Installation kit incl. fastening materials
hot-galvanised

for KD...	00 504 078
for KE...	00 504 080
for KES...	00 504 513

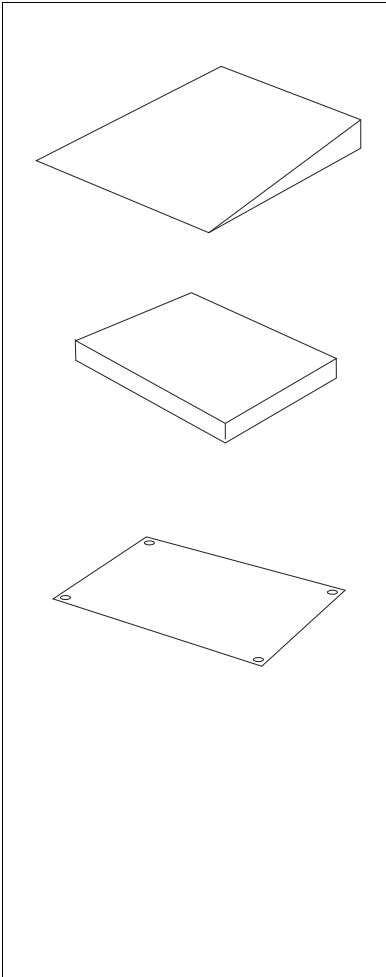

Order No.

Access ramp

00 503 638

for KC300, KCS300, KC600,
KCS600

Symmetrical steel design, hot-
galvanised checker plate surface
Loading capacity 1000 kg

Additional load plate

00 503 629

for KC300, KC600

polished stainless steel
Bell-shaped for placing over
existing load plate
Surface protection for stricter
hygienic requirements

Load plates

for KD...

enamelled	00 503 617
hot-galvanised	00 503 618
stainless steel	00 503 619

for KE...

enamelled	00 503 620
hot-galvanised	00 503 621
stainless steel	00 503 622

for KES...

enamelled	00 504 504
hot-galvanised	00 504 505
stainless steel	00 504 506

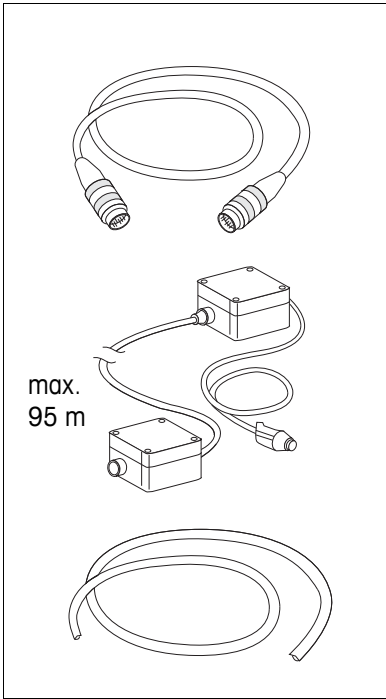

Order No.

Extension cable

00 504 134

Length 10 m, connector at both ends
for remote setup of ID terminal

Cable adapter kit for ID terminals 00 504 133

for infinite extension of connection cable to 100 m
comprising two junction boxes
Box at terminal end with connection cable of 2.5 m length

Special cable from the roll 00 504 177

used with adapter kit for ID terminals for infinite extension of connection cable to required length

7 Technical data of the measuring cell

Types	TBrick 6, TBrick 15, TBrick 32
Ignition protection type	II 3G Ex nA II T6 -10 °C ≤ T _a ≤ +40 °C II 3D Ex tD A22 IP67 T 70 °C DMT 02 E 012 The following safety-related variables must be ensured by the connected weighing terminal:
	Supply circuit U _{max} ≤ 20 V DC
	Interface circuit U _{max, CL} ≤ 27 V DC I _{max, CL} ≤ 30 mA U _{max Diff, RS422} ≤ 10 V DC
Power consumption	12 V DC ± 20 %; 125 mA; 1.4 VA
IP protection type	IP67

8 Disposal



In accordance with the requirements of the European Directive 2002/96 EC about Waste Electrical and Electronic Equipment (WEEE) this equipment may not be disposed of in the household refuse.

This applies correspondingly for countries outside the EC in accordance with the applicable national regulations.

→ Please dispose of this product in accordance with the local regulations in a separate collection for electrical and electronic equipment.

Should you have any questions, please contact the responsible authorities or the dealer from whom you purchased this equipment.

If this equipment is passed on (for example for private or commercial/ industrial further use), this specification has to be passed on correspondingly as well.

Many thanks for your contribution to protecting the environment.

METTLER TOLEDO Service

METTLER TOLEDO products stand for highest quality and precision. Careful handling in accordance with these operating instructions as well as regular maintenance and inspection by our professional customer service ensure the long and reliable function and maintenance of value of your measuring instruments. Our experienced service team will be pleased to inform you about corresponding service agreements or calibration services.

Please register your new product under www.mt.com/productregistration, so that we can inform you about improvements, updates and further important information about your METTLER TOLEDO product.



22007218E

Subject to technical changes © Mettler-Toledo (Albstadt) GmbH 09/12 Printed in Germany 22007218E

Mettler-Toledo (Albstadt) GmbH

D-72458 Albstadt

Tel. ++49-7431-14 0, Fax ++49-7431-14 232

Internet: <http://www.mt.com>