

Guide for installers

METTLER TOLEDO MultiRange Explosion proof weighing system with IND226x weighing terminal

METTLER TOLEDO

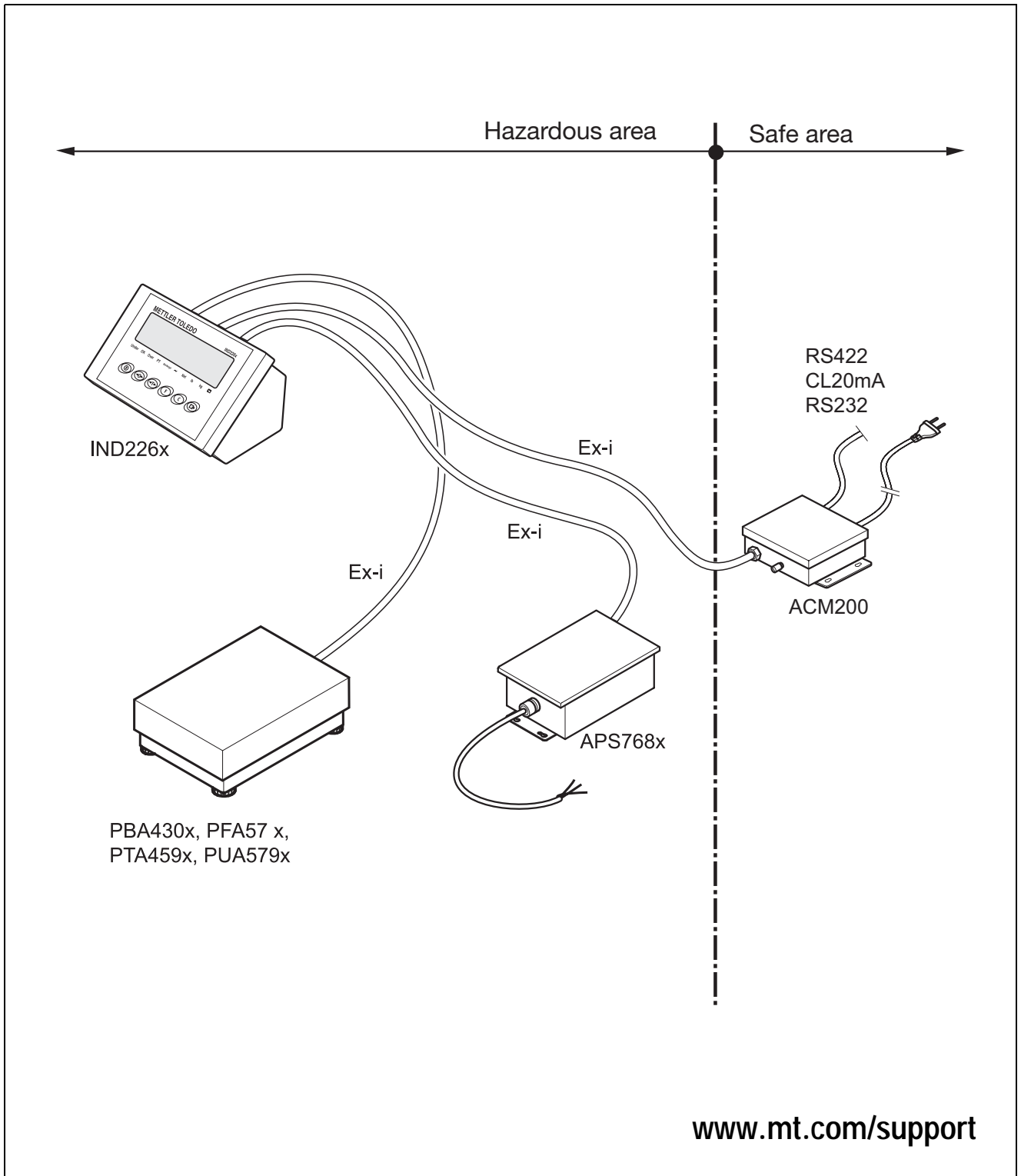

www.mt.com/support

Contents		Page
1	Safety instructions	4
2	System overview	6
2.1	Typical configurations	6
2.2	Description of components	8
3	Installation	10
3.1	Setting up system modules	10
3.2	Connecting devices	11
3.3	Selecting peripheral devices	13
3.4	Installing the equipotential bonding.....	14
3.5	Connecting power supply	14
4	Optional work	15
4.1	Customizing connection cables: Weighing platform / APS768x.....	15
4.2	Connection cable extension power supply unit APS500 / APS501	16
4.3	Customizing connection cables: Second display / interface converter ACM200	18
4.4	Configuring module ACM200-CL/RS422	19
5	Technical data	20
5.1	Dimensional drawing	20
5.2	Technical data of the CL20mA interface of the module ACM200-CL/RS422	21
6	Disposal	22
7	Terminal diagram	24

1 Safety instructions



The IND226x weighing terminal is approved for operation in Zone 1 and 21 hazardous areas as well as for Division 1 areas. The interface converter ACM200 may only be installed and operated in the safe area.

If the IND226x weighing terminal is used in hazardous areas, special care must be taken. The code of practice is oriented to the "Safe Distribution" concept drawn up by METTLER TOLEDO.

- Competence**
- ▲ The weighing system may only be installed, maintained and repaired by authorized METTLER TOLEDO service personnel.
 - ▲ The mains supply may only be installed by a specialist authorised by the owner-operator.
- Ex approval**
- ▲ No modifications may be made to the terminal and no repair work may be performed on the modules. Any weighing platform or system modules that are used must comply with the specifications contained in the installation instructions. Non-compliant equipment jeopardizes the intrinsic safety of the system, cancels the "Ex" approval and renders any warranty or product liability claims null and void.
 - ▲ The safety of the weighing system is only guaranteed when the weighing system is operated, installed and maintained in accordance with the respective instructions.
 - ▲ Also comply with the following:
 - the instructions for the system modules,
 - the regulations and standards in the respective country,
 - the statutory requirement for electrical equipment installed in hazardous areas in the respective country,
 - all instructions related to safety issued by the owner.
 - ▲ The explosion-protected weighing system must be checked to ensure compliance with the requirements for safety before being put into service for the first time, following any service work and every 3 years, at least.
- Operation**
- ▲ Prevent the build-up of static electricity. Always wear suitable working clothes when operating or performing service work in a hazardous area.
 - ▲ Do not use protective coverings for the devices.
 - ▲ Protect the keyboard membrane against ultraviolet radiation.
 - ▲ Avoid damage to the system components.

- Installation**
- ▲ Only install or perform maintenance work on the weighing system in the hazardous areas if the following conditions are fulfilled:
 - if the intrinsically safe characteristic values and zone approval of the individual components are in accord with one another,
 - the owner has issued a permit ("spark permit" or "fire permit"),
 - the area has been rendered safe and the owner's safety co-ordinator has confirmed 11/12 there is no danger,
 - the necessary tools and any required protective clothing are provided (danger of the build-up of static electricity).
 - ▲ The certification papers (certificates, manufacturer's declarations) must be present.
 - ▲ Lay cabling securely so that it does not move and effectively protect it against damage.
 - ▲ Only route cables into the housing of the system modules via the approved earthing cable glands and ensure proper seating of the seals.

2 System overview

2.1 Typical configurations

A weighing system with the IND226x weighing terminal can be operated either with one of the following power supply units or with an external storage battery:

APS500	Power supply unit in a hazardous area, US version, 120 VAC, 50/60 Hz
APS501	Power supply unit in a hazardous area, EU version, 240 VAC, 50/60 Hz
APS768x-120 V	Power supply unit in a hazardous area, US version, 120 VAC, 50/60 Hz
APS768x-230 V	Power supply unit in a hazardous area, EU version, 230 VAC, 50 Hz
External NiMH Battery Pack	External storage battery for a hazardous area, charging only in a non-hazardous area and using a charger specified and approved by METTLER TOLEDO

Either an analog weighing platform or the system solution Analog Ex1 can be connected to the weighing IND226x terminal.

The following components are necessary for connection of peripheral devices:

Interface IND	Active intrinsically safe data interface, installed in IND226x (Master)
Interface Remote	Passive intrinsically safe data interface, for remote control of an IND226x (IND226x as a second display), installed in IND226x (second display)
ACM200	Interface converter for the safe area, for example, for connection of a PC in the safe area Wide range power supply unit 100 – 240 V AC, 50/60 Hz or 24 V DC

2.1.1 Configuration with interface converter ACM200 in the safe area

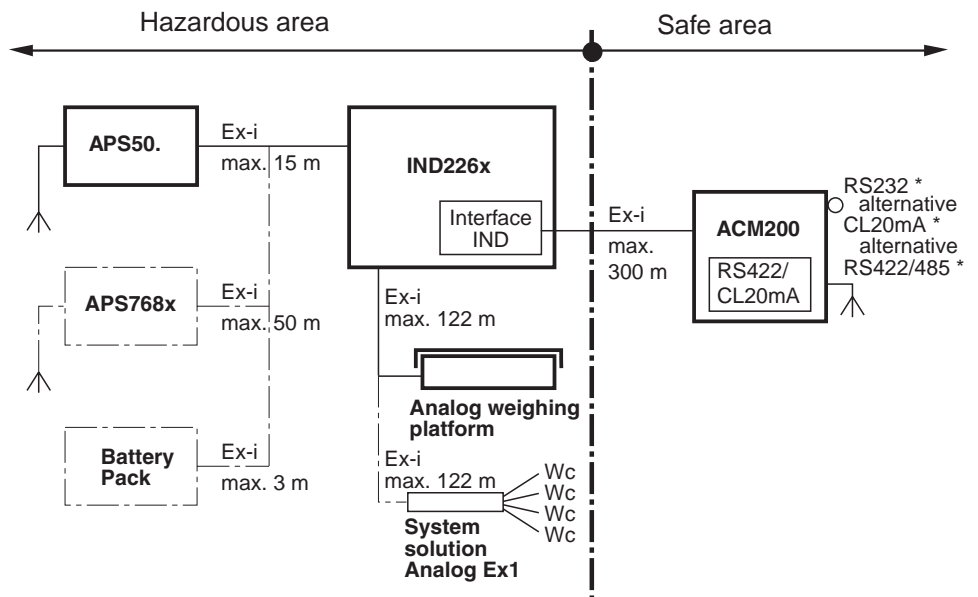

* only one hardware interface available, CL20mA and RS422/485 only with module ACM200-CL/RS422
Dashed-line components are alternatives.

2.1.2 Configuration with remote controlled IND226x (second display)

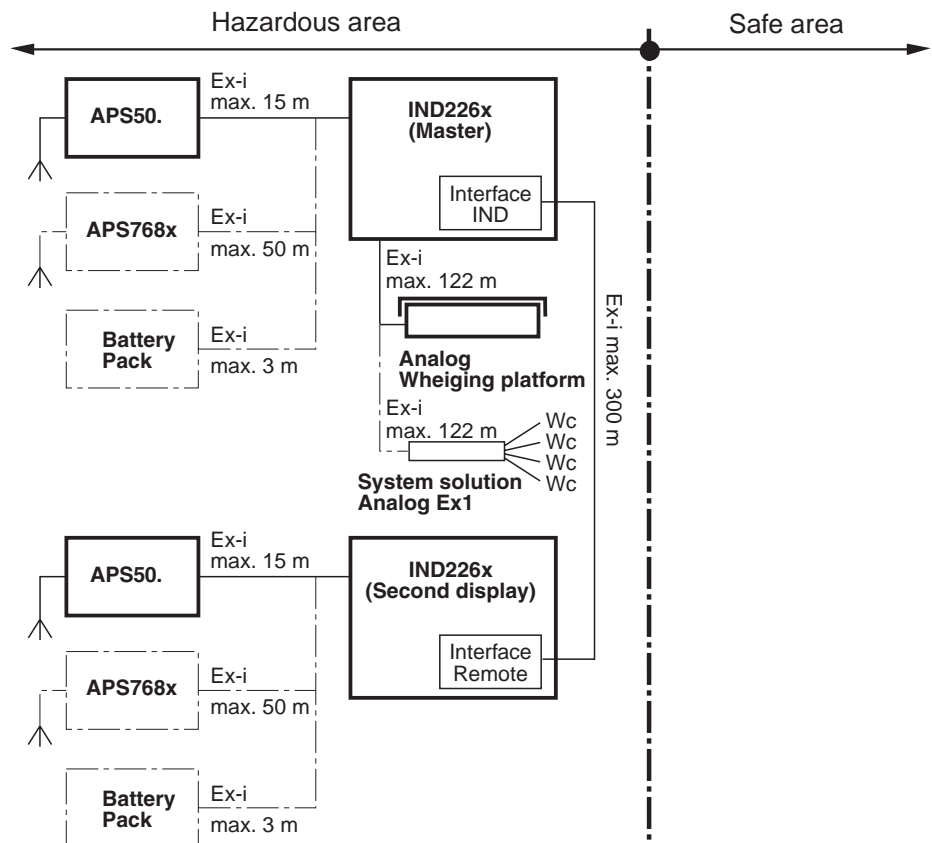

Dashed-line components are alternatives.

2.1.3 Configuration with interface converter ACM200 and power supply unit APS768x

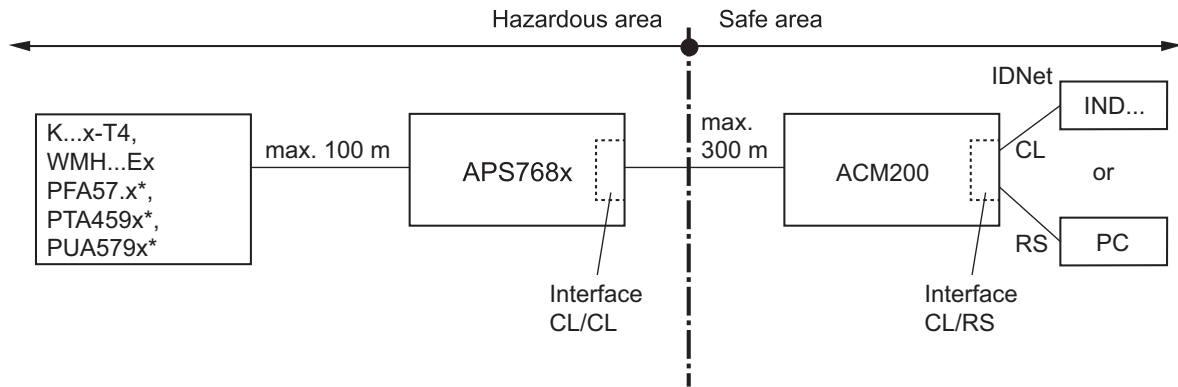

* IDNet version

2.2 Description of components

2.2.1 Approvals

IND226x weighing terminal	Ignition protection type	EN / IEC Ex	II 2G II 2D	Ex ib IIC T4 Gb, -10 °C ... +40 °C Ex ib IIIC T60°C Db
Interface IND		cFM_{US}		IS Class I, II, III; Division 1;
Interface Remote				Group A, B, C, D, E, F, G; T _q = 40 °C
Power supply unit APS500 / APS501	See documentation on APS500 / APS501			
Power supply unit APS768x	See APS768x Guide for installers			
External Battery Pack	See documentation on External NiMH Battery Pack			
Analog weighing platforms	See Operating instructions / Installation information of the weighing platforms			
System solution Analog Ex1	See Guide for installers of the System solution Analog Ex1			
Interface converter ACM200	Ignition protection type	EN / IEC Ex	II (2)G II (2)D	[Ex ib Gb] IIC [Ex ib Db] IIIC
		cFM_{US}		AIS Class I, II, III; Division 1; Group A, B, C, D, E, F, G

2.2.2 Connections

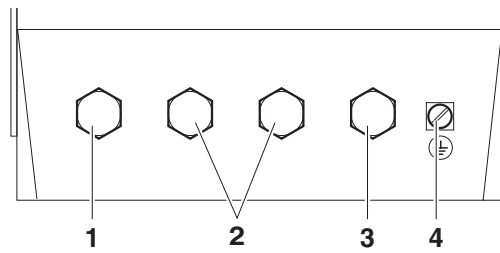

- 1 Weighing platform connection;
earthing cable gland M16x1.5 included in supply
- 2 Connection of interface converter ACM200 or digital input;
blind plugs mounted at the factory
- 3 Connection of power supply unit / External Battery Pack;
earthing cable gland M16x1.5 included in supply
- 4 Equipotential bonding terminal (EB)

3 Installation



EXPLOSION HAZARD

The explosion-protected weighing system may only be installed according to these installation instructions and the terminal diagram 72203677 on Pages 24 to 29.

3.1 Setting up system modules

3.1.1 Setting up the IND226x weighing terminal

→ Select a suitable installation site.

Bench stand or floor stand mounting

→ Place weighing terminal onto the bench or floor stand and mount with 4 screws.

Wall mounting

→ The IND226x weighing terminal can be mounted to a wall using the wall bracket (accessory).

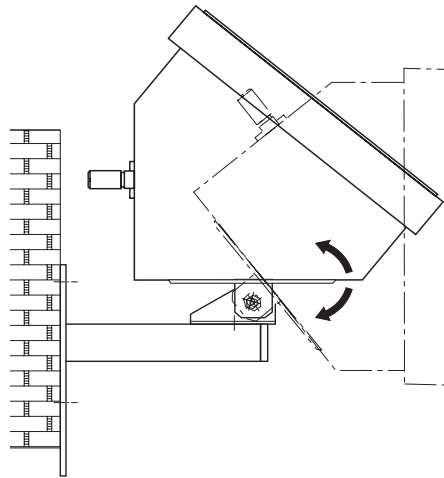

3.1.2 Setting up the power supply unit

→ Set up the power supply unit in accordance with the corresponding instructions.

3.1.3 Setting up the weighing platform

→ Set up the analog weighing platform in accordance with the corresponding operating and installation instructions.

Set up the system solution Analog Ex1 in accordance with the corresponding installation instructions.

3.1.4 Setting up the ACM200

- Set up the interface converter ACM200 in the safe area.
See dimensional drawing on Page 20 for drill hole dimensions for fixed installation.

3.2 Connecting devices

CAUTION

- The clamping section of the earthing cable gland must agree with the outer diameter of the weighing platform cable to be connected.
- Use the supplied flexible tubes to protect the individual wires of the weighing platform cable on the inside of the IND226x.

Connect the devices in the following order:

1. Connect the weighing platform or system solution Analog Ex1 to the weighing terminal IND226x.
2. If present, connect intrinsically safe equipment (e.g. a simple switch / push button) to the intrinsically safe input of the weighing terminal IND226x.
3. Connect the power supply unit (APS500 / APS501, APS768x or External Battery Pack) to the weighing terminal IND226x.
4. Connect the interface converter ACM200, if present, to the weighing terminal IND226x.
5. Install the equipotential bonding, see Section 3.4.
6. Connect power supply, see Section 3.5.

3.2.1 Preparatory work

Connection of the devices is generally carried out with the accompanying standard cables. Cables of other lengths can be used instead of the standard cables if they are customized in accordance with Chapter 4. This applies for the following connections

- from the weighing platform or system solution Analog Ex1 to the weighing terminal,
- from the power supply unit APS500 / APS501 or APS768x to the weighing terminal,
- from the interface converter ACM200 to the weighing terminal.

3.2.2 General connection procedure

1. Open the device.
2. Pull the customized cable through the earthing cable gland. To do this
 - dismantle the earthing cable gland or remove the blind plug,
 - ensure the exact course of the cable and properly positioned seals,
 - tighten the earthing cable gland.
3. Connect the cable in the device according to the terminal diagram.
4. For the power supply unit **APS500 / APS501** connect the cable shield to the terminal housing.

At an **External NiMH battery pack** check whether the cable shield is connected to the "Ex-e" explosion-proof cable gland. If not, connect the cable shield to the housing frame

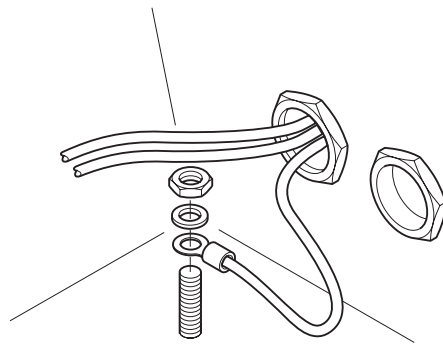

5. Lay the cable in the cable holders on the inside of the housing.
6. Close device.

3.2.3 Installing/connecting the serial data interface

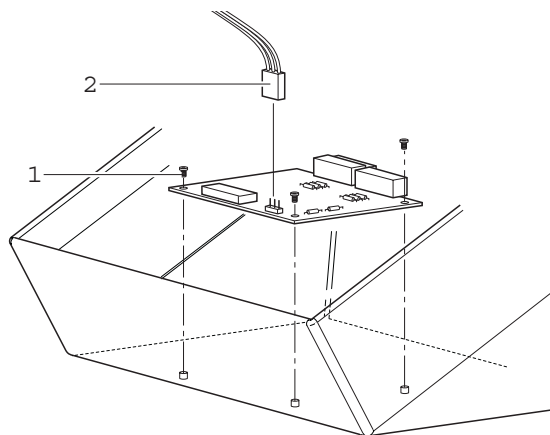

1. Secure the Interface IND or Interface Remote to the securing bolts with 3 stainless steel screws (1).
2. Plug the included interface cable (2) into connector J2 on the serial data interface and into connector J4 on the mainboard IND226x.
3. Connect the peripheral device to connector COM4 of the serial data interface according to terminal diagram 72203677.

3.2.4 Connection of the digital input at the IND226x

CAUTION

Design, calculation and installation of equipment at the digital input is **solely the responsibility of the owner**, see section 3.3.

1. Connect only certified devices which are approved for Zone 1/21 or Division 1 hazardous areas.
When dimensioning the device to be connected, take the particularly low current/voltage value of the active input of the IND226x into consideration.
2. Check the characteristic values for intrinsic safety in accordance with the conformity certificate of the IND226x and the equipment to be connected according to the conditions in Section 3.3. Document checking of the characteristic values.
3. Customize a cable on the weighing terminal side in accordance with Section 4.3 and on the peripheral side according to the device to be connected. Heed the maximum cable length here.
4. Connect the cable on the peripheral device side according to the intended device. Ensure correct polarity here!

3.3 Selecting peripheral devices

CAUTION

Refer to the approval documentation of the peripheral device for all characteristic values of the peripheral device listed in the following.

The following conditions must be fulfilled. See also terminal diagram IND226x:

1. U_i (peripheral device) $\geq U_0$ (IND226x)
2. I_i (peripheral device) $\geq I_0$ (IND226x)
3. P_i (peripheral device) $\geq P_0$ (IND226x)
4. C_i (peripheral device) + $C_{\text{cable}} \leq C_0$ (IND226x)
5. L_i (peripheral device) + $L_{\text{cable}} \leq L_0$ (IND226x)
6. $L_{a \text{ max}}$ (peripheral device) / R_a (peripheral device) $< L_{\text{cable}} / R_{\text{cable}}$.
with L_{cable} being the length-based inductivity and R_{cable} the length-specific resistance of the cable to be used.

ATEX Directive for connection to the active input

In the case of a simple apparatus in accordance with Section 5.7 EN/IEC 60079-1, the external simple apparatus in a hazardous gas environment does not require an identification for use in Zone 1.

In a hazardous dust environment, Table 1 of the EN/IEC 61241-11 has to be taken into consideration, for example the relevant regulation has to be applied for the certified output $P_0 = 1.4 \text{ mW}$.

FM Directive for connection to the active input

A simple apparatus is defined in Section 504.2 of the National Electric Code (NFPA 70) as "An electrical component or combination of components of simple construction with well-defined electrical parameters that does not generate more than 1.5 volts, 100 milliamps, and 25 milliwatts, and is compatible with the intrinsic safety of the circuit in which it is used."

Section 504.4 of the National Electric Code states that "simple apparatus, as described on the control drawing, shall not be required to be listed".

3.4 Installing the equipotential bonding

Equipotential bonding must be installed by an electrician authorized by the owner. METTLER TOLEDO Service only has a monitoring and consulting function here.

- Connect equipotential bonding (EB) of all devices (power supply unit, weighing terminal, interface converter and weighing platform) in accordance with the terminal diagram and the country-specific regulations and standards. In the process it must be ensured that
 - all device housings are connected to the same potential via the EB terminals,
 - no circulating current flows via the cable shielding for intrinsically safe circuits,
 - the neutral point for equipotential bonding is as close to the weighing system as possible.

3.5 Connecting power supply

**EXPLOSION HAZARD**

The mains connection of the power supply unit must be made by a professional electrician authorized by the owner and in accordance with the respective terminal diagram, the accompanying installation instructions as well as the country-specific regulations.

4 Optional work

4.1 Customizing connection cables: Weighing platform / APS768x

Customer-specific cables for intrinsically safe circuits must be customized as follows:

	Cable	Dimension A (IND226x)	Dimension B	Max. length
IND226x – APS768x	4x2x0.5 mm ² + 1x0.5 mm ²	215 mm	80 mm	50 m
IND226x – Weighing platform / system solution Analog Ex1	3x2x0.75 mm ²	215 mm	80 mm	122 m

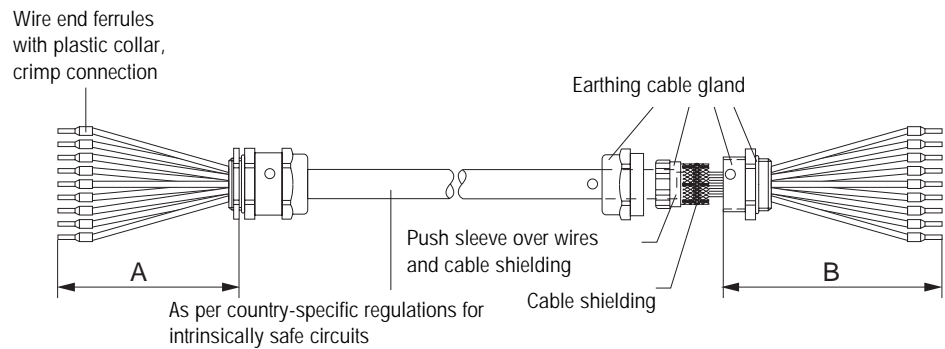

1. Cut cable to length and strip cable ends according to dimension A/B.
2. Shorten cable shielding on both sides to 10 mm.
3. Strip wire ends.
4. Crimp wire end ferrules onto wire ends with a crimping tool.
5. Push second rear section of earthing cable gland onto cable.
6. Push sleeve over wires and cable shielding. Fold over cable shielding.
7. Push on front section of cable gland and screw onto rear section.

4.2 Connection cable extension power supply unit APS500 / APS501

The connection cable premounted at the power supply unit APS500 / APS501 cannot be replaced. Therefore, a junction box is required in order to extend the connection cable. This is available as an accessory (for the Order Number please refer to the technical documentation of the power supply unit APS500 / APS501).

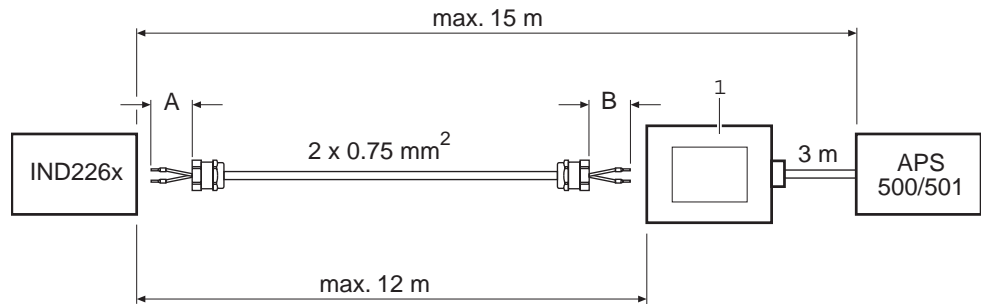

1 Junction box with junction PCB

4.2.1 Customizing cables

Customer-specific cables for intrinsically safe circuits must be customized as follows:

	Cable	Dimension A (IND226x)	Dimension B	Max. length
IND226x – APS500/501	2x0.75 mm ²	215 mm	80 mm	12 m

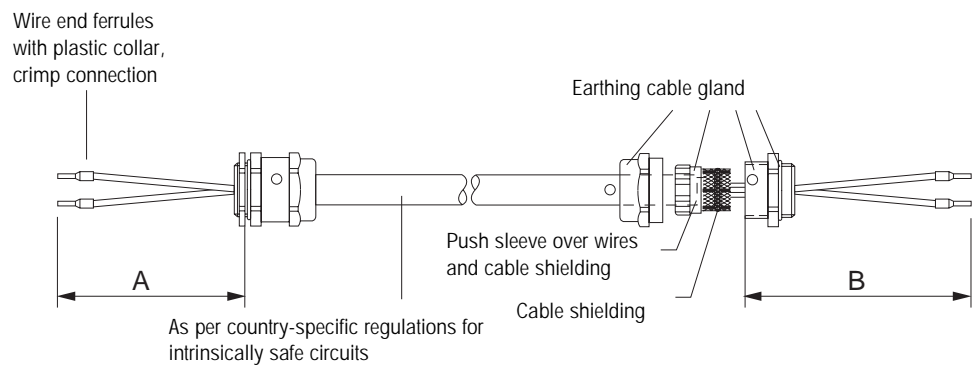

1. Cut cable to length and strip cable ends according to dimension A/B.
2. Shorten cable shielding on both sides to 10 mm.
3. Strip wire ends.
4. Crimp wire end ferrules onto wire ends with a crimping tool.
5. Push second rear section of earthing cable gland onto cable.
6. Push sleeve over wires and cable shielding. Fold over cable shielding.
7. Push on front section of cable gland and screw onto rear section.

4.2.2 Connecting

APS500 / APS501 – junction box

1. Introduce the premounted Ex-i connection cable via a suitable and approved earthing cable gland into the junction box.
2. Ensure correct positioning of the seal and tighten the earthing cable gland.
3. Connect the conductors of the premounted connection cable to the junction PCB of the junction box.
Place cable shielding on the junction box housing.
See the documentation on APS500 / APS501 for the connection assignment.

Junction box – IND226x

1. Introduce the customized customer-specific Ex-i connection cable via the supplied earthing cable gland into the junction box.
2. Ensure correct positioning of the seal and tighten the cable gland.
3. Connect the conductors of the customized connection cable to the junction PCB of the junction box.
See the documentation on APS500 / APS501 for the connection assignment.
4. Introduce the customized customer-specific cable into the IND226x and connect it in accordance with the terminal diagram 72203677 found on page 24.

4.3 Customizing connection cables: Second display / interface converter ACM200

Customer-specific cables for intrinsically safe circuits must be customized as follows:

	Cable	Dim. A IND226x (M)	Dim. B	Max. length
IND226x (Master) – IND226x IND226x – ACM200	2x2x0.5 mm ²	50 mm	50 mm	300 m

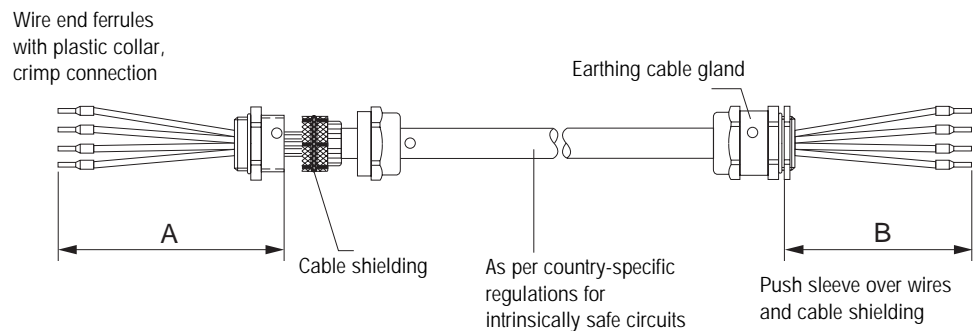

1. Cut cable to length and strip cable ends according to dimension A/B.
2. Shorten cable shielding on both sides to 10 mm.
3. Strip wire ends.
4. Crimp wire end ferrules onto wire ends with a crimping tool.
5. Push second rear section of earthing cable gland onto cable.
6. Apply the cable shielding only on the IND226x (Master) end.
To do so, push the sleeve over the wires and cable shielding and fold over the cable shielding.
7. Push on front section of cable gland and screw onto rear section.



4.4 Configuring module ACM200-CL/RS422

4.4.1 Opening the housing

1. Pull the power plug.
2. Open the housing cover of the ACM200.

4.4.2 Setting the jumpers

→ Plug in the jumpers W1 to W5 as per the table below.

Jumper	Meaning	Factory setting	Note
W2	CL20mA interface	Plugged in	The transmission and reception loop operating mode can also be selected, see 4.4.3
W3	RS422 interface	–	A matching resistor W1 can also be set
W4	RS485 interface	–	
W1	Matching resistor	Open, no matching resistor	Only for RS422/RS485, the matching resistor is required only on the last component of a field bus
W5	Power supply	"12 V" position	With the used wide-range power supply unit, it is necessary to insert the jumper in the "12 V" position

4.4.3 Selecting the CL interface operating mode for the module ACM200-CL/RS422

The CL interface of the optional module ACM200-CL/RS422 can be operated with either an active or passive transmission and reception loop.

Factory setting: Passive transmission and reception loop

1. Pull the power plug.
2. Open the housing cover of the ACM200.
3. Set the desired operating mode with the dip switch K1 on the module ACM200-CL/RS422.



Operating mode	K1	K2	K3	K4	K5	K6
TXD passive, RXD passive (factory setting)	on	on	off	off	off	off
TXD active, RXD active	off	off	on	on	on	on
TXD passive, RXD active	off	on	on	on	off	off
TXD active, RXD passive	on	off	off	off	on	on

4.4.4 Closing the housing

→ Close the housing cover. Ensure correct position of the seal when doing so.

5 Technical data

5.1 Dimensional drawing

IND226x

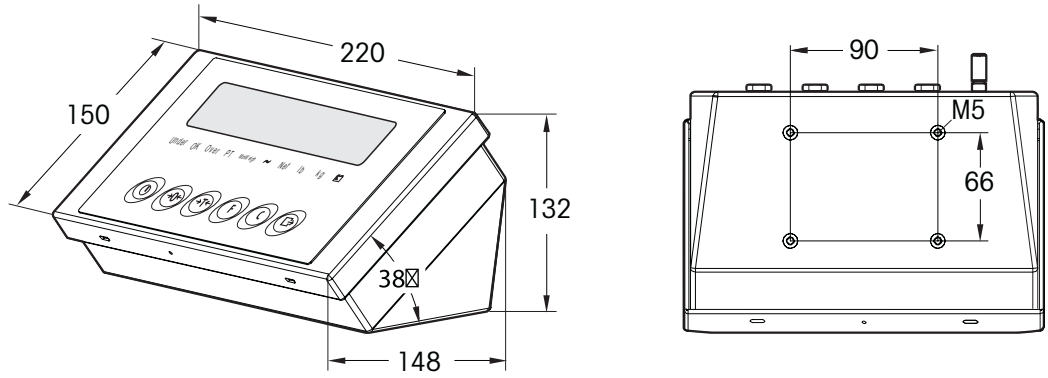

Dimensions in mm

ACM200

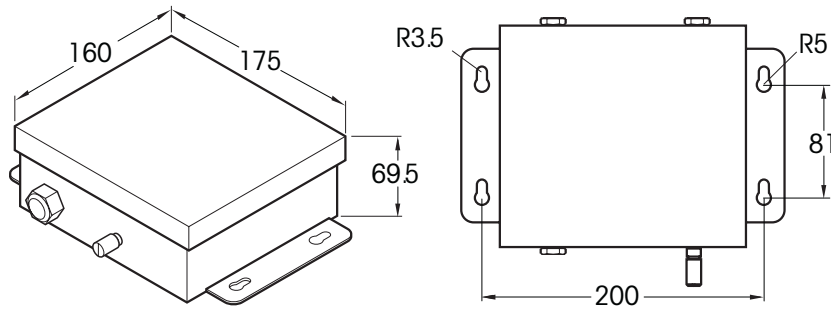

Dimensions in mm

5.2 Technical data of the CL20mA interface of the module ACM200-CL/RS422

Type of interface	<ul style="list-style-type: none"> • 20 mA current loop, 2 transmission loops • Active or passive operation • Signal level 0: 20 mA • Signal level 1: 0 mA • Electrical isolation only in passive configuration and up to U = 30 VAC, \bar{U} = 42 V, U = 60 VDC 												
Interface parameters	<table> <tr> <td>Operating mode</td> <td>Full duplex</td> </tr> <tr> <td>Transmission type</td> <td>Bit serial, asynchronous</td> </tr> <tr> <td>Transmission code</td> <td>ASCII</td> </tr> <tr> <td>Data bits</td> <td>7/8</td> </tr> <tr> <td>Parity</td> <td>Even, odd, zero, one, none</td> </tr> <tr> <td>Baud rate</td> <td>150, 300, 600, 1200, 2400, 4800, 9600, 19200</td> </tr> </table>	Operating mode	Full duplex	Transmission type	Bit serial, asynchronous	Transmission code	ASCII	Data bits	7/8	Parity	Even, odd, zero, one, none	Baud rate	150, 300, 600, 1200, 2400, 4800, 9600, 19200
Operating mode	Full duplex												
Transmission type	Bit serial, asynchronous												
Transmission code	ASCII												
Data bits	7/8												
Parity	Even, odd, zero, one, none												
Baud rate	150, 300, 600, 1200, 2400, 4800, 9600, 19200												
Transmission and/or reception loop passive	<p>One external power source supplies the transmission and/or reception loop</p> <table> <tr> <td>I_{\max}</td> <td>30 mA</td> </tr> <tr> <td>U_{\max}</td> <td>27 V</td> </tr> <tr> <td>Voltage range</td> <td>15 V (+10 % / -0 %)</td> </tr> <tr> <td>Current level</td> <td>18 mA – 24 mA (high level)</td> </tr> <tr> <td>Edge steepness</td> <td>2 – 20 mA/μs</td> </tr> </table> <p>To set operating mode, see Section 4.4.2</p>	I_{\max}	30 mA	U_{\max}	27 V	Voltage range	15 V (+10 % / -0 %)	Current level	18 mA – 24 mA (high level)	Edge steepness	2 – 20 mA/ μ s		
I_{\max}	30 mA												
U_{\max}	27 V												
Voltage range	15 V (+10 % / -0 %)												
Current level	18 mA – 24 mA (high level)												
Edge steepness	2 – 20 mA/ μ s												
Transmission and/or reception loop active	<p>One internal power source supplies the transmission and/or reception loop</p> <table> <tr> <td>Voltage</td> <td>12 VDC</td> </tr> <tr> <td>Current</td> <td>Adjusted to ± 2 mA, for transmission and/or reception loop</td> </tr> </table> <p>To set operating mode, see Section 4.4.2</p>	Voltage	12 VDC	Current	Adjusted to ± 2 mA, for transmission and/or reception loop								
Voltage	12 VDC												
Current	Adjusted to ± 2 mA, for transmission and/or reception loop												
Cable	<ul style="list-style-type: none"> • Shielded, twisted pair • Line resistance $\leq 125 \Omega/\text{km}$ • Line cross-section $\geq 0.14 \text{ mm}^2$ • Line capacity $\leq 130 \text{ nF/km}$ • Max. 1000 m for baud rates up to 4800 baud • Max. 600 m for 9600 baud • Max. 300 m for 19200 baud 												

6 Disposal



In conformance with the European Directive 2002/96/EC on Waste Electrical and Electronic Equipment (WEEE), this device may not be disposed of in domestic waste. This also applies to countries outside the EU as per their specific regulations.

→ Please dispose of this product in accordance with local regulations at the collecting point specified for electrical and electronic equipment.

If you have any questions, please contact the responsible authority or the distributor from which you purchased this device.

Should this device be passed on to other parties (for private or professional use), the content of this regulation must also be related.

Thank you for your contribution to environmental protection.

7 Terminal diagram

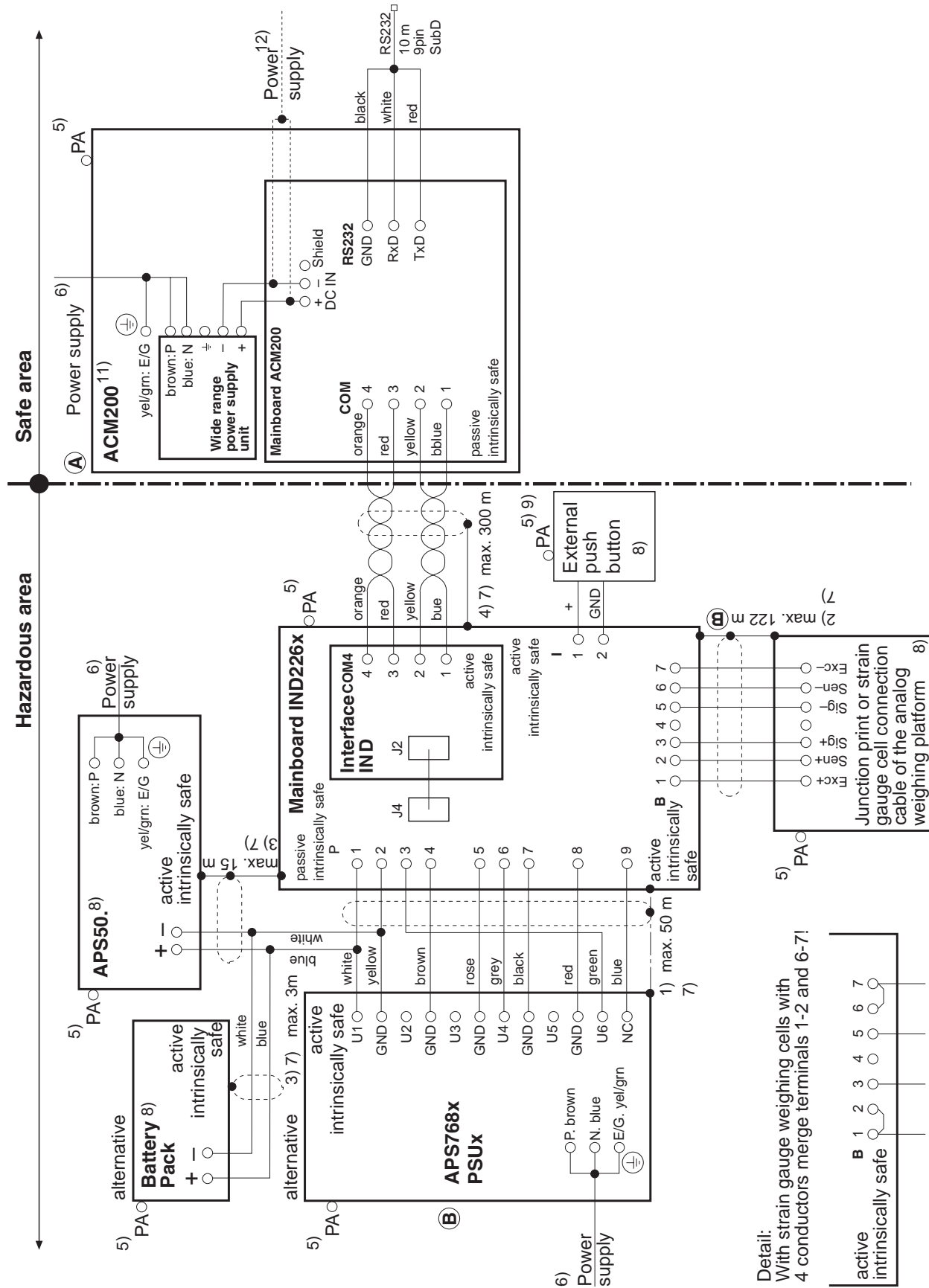

IND226x – Intrinsically safe entity parameters

Scale interface	U ₀ (V _{oc})	I ₀ (I _{sc})	P ₀	C ₀ (C _a)	L ₀ (L _a)
Terminals B 1–7	5.88 V	156 mA	0.92 W	200 nF	0.3 mH

Digital input (active)	U ₀ (V _{oc})	I ₀ (I _{sc})	P ₀	C ₀ (C _a)	L ₀ (L _a)
Terminals I 1–2	5.4 V	1 mA	1.4 mW	100 nF	0.1 mH

Power supply	U _i	I _i	P _i	C _i	L _i
Terminals P 1–9	13 V	3.16 A	12 W	0 nF	0 mH
		limited internally			

Interface IND	U ₀ (V _{oc})	I ₀ (I _{sc})	P ₀	C ₀ (C _a)	L ₀ (L _a)
COM4, Terminals 1–4	5.88 V	144 mA	212 mW	600 nF	0.4 mH

Interface Remote	U _i	I _i	P _i	C _i	L _i
COM4, Terminals 1–4	10 V	300 mA	500 mW	120 nF	0 mH

ACM200 – Intrinsically safe entity parameters

Passive interface	U _i	I _i	P _i	C _i	L _i
COM, Terminals 1–4	10 V	300 mA	500 mW	120 nF	0 mH

Weighing platform characteristics

Measuring cells max. 4
 Weighing platform impedance $\geq 87 \Omega$
 Nominal characteristic load cell 2 mV/V or 3 mV/V

Color codes	RWMx PFA579x	PFA575x PFA459x PUA579x	DB...sTx DCS...sTx	PBA430x
Exc+	gray	gray	blue	green
Sen+	yellow	yellow	green	blue
Sig+	white	white	white	white
Sig-	brown	brown	red	red
Sen-	green	green	gray	brown
Exc-	pink	pink	black	black

CENELEC approval	cFM _{US} approval
Cables conforming to EN50039 and EN60079-14 for intrinsically safe circuits	For installation please refer to ANSI/ISA RP 12.06.01, "Installation of intrinsically safe devices in Class I hazardous areas" Cable as per country-specific regulations for intrinsically safe circuits
<ul style="list-style-type: none"> Cable inlet via earthing cable gland Cable as per installation instructions ME-72203959 	
1) Cable 4 x 2 x 0.5 mm ² + 1 x 0.5 mm ² (4 x 2 x 0.02 in ² + 1 x 0.02 in ²) shielded and twisted pair 2) Cable 3 x 2 x 0.75 mm ² (3 x 2 x 0.03 in ²) shielded and twisted pair 3) Cable 2 x 0.75 mm ² (2 x 0.03 in ²) shielded and twisted pair 4) Cable 2 x 2 x 0.5 mm ² (2 x 2 x 0.02 in ²) twisted pair and cable shield only applied to IND226x end	
5) Connection of equipotential bonding (EB) as per country-specific regulations. It must be ensured that the housings of all devices are connected to the same potential via the EB terminals. No circulating current may flow via the shielding of the intrinsically safe cables.	5) Connection of the equipotential bonding (EB) as per ANSI/NFPA 70, Article 504 and ANSI/IA RP 12.06.01 or Canadian Electrical Code C22.2. It must be ensured that the housings of all devices are connected to the same potential via the EB terminals. No circulating current may flow via the shielding of the intrinsically safe cables.
6) Mains connection in accordance with country-specific regulations; for supply voltage and frequency refer to rating plate	
7) Lay cabling securely so that it does not move and effectively protect it against damage.	
8) ATEX- and FM-approved devices in accordance with following conditions: $U_i \geq U_0 (V_{oc})$ $I_i \geq I_0 (I_{sc})$ $P_i \geq P_0$ $C_i + C_{cable} < C_0 (C_a)$ $L_i + L_{cable} < L_0 (L_a)$ Active input: Connection of simple electrical apparatus in accordance with NEC (NFPA 70), Sections 504.2 and 504.4	
9) For connecting devices with a maximum effective value of U _m = 250 V rms or DC.	
10) Use only shielded cable. Max. cable length 304 m. Cable cross section: min. 0.2 mm ² , max. 0.8 mm ²	
11) Can also be used in conjunction with the power supply unit APS768x, see terminal diagram 22006397	
12) A power supply with 24 V DC is possible in the case of device variant ACM200-DC	
Ambient temperature range: -10 °C to +40 °C (14 °F to 104 °F)	

C		11/12	Schultz				
B		11/03	Schultz				
A		09/07	Schultz	Date	Name	Scale	Designation
Edition	Change	Date	Name	Proc. by	05/07	Schultz	Terminal diagram IND226x
				Checked	05/07	Schultz	
Replacement for: /				Sheet 1/3			
Mettler-Toledo (Changzhou) Measurement Technology Ltd.							Code 72203677

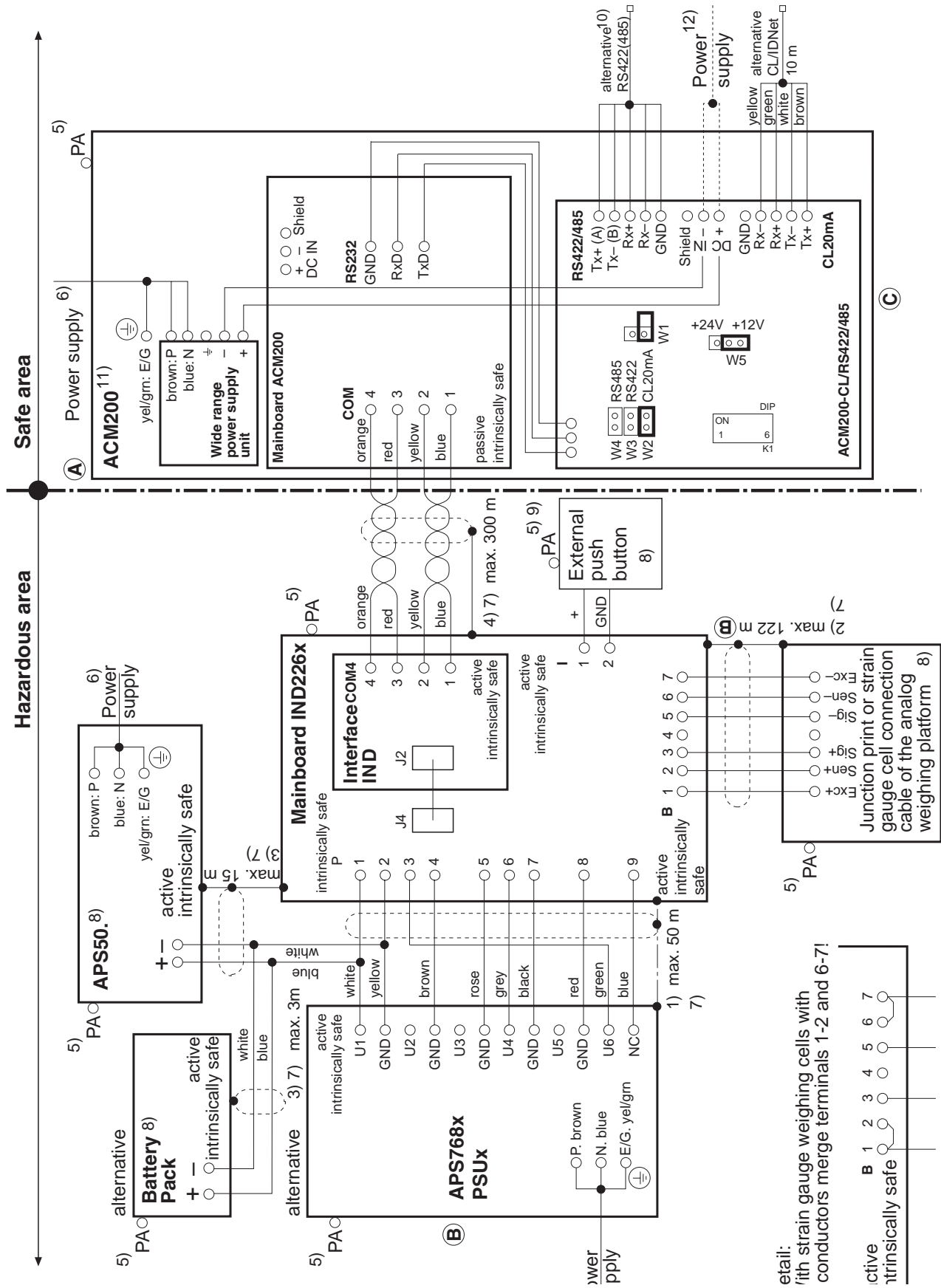

IND226x – Intrinsically safe entity parameters

Scale interface	U_0 (V_{oc})	I_0 (I_{sc})	P_0	C_0 (C_a)	L_0 (L_a)
Terminals B 1–7	5.88 V	156 mA	0.92 W	200 nF	0.3 mH

Digital input (active)	U_0 (V_{oc})	I_0 (I_{sc})	P_0	C_0 (C_a)	L_0 (L_a)
Terminals I 1–2	5.4 V	1 mA	1.4 mW	100 nF	0.1 mH

Power supply	U_i	I_i	P_i	C_i	L_i
Terminals P 1–9	13 V	3.16 A limited internally	12 W	0 nF	0 mH

Interface IND	U_0 (V_{oc})	I_0 (I_{sc})	P_0	C_0 (C_a)	L_0 (L_a)
COM4, Terminals 1–4	5.88 V	144 mA	212 mW	600 nF	0.4 mH

Interface Remote	U_i	I_i	P_i	C_i	L_i
COM4, Terminals 1–4	10 V	300 mA	500 mW	120 nF	0 mH

ACM200 – Intrinsically safe entity parameters

Passive interface	U_i	I_i	P_i	C_i	L_i
COM, Terminals 1–4	10 V	300 mA	500 mW	120 nF	0 mH

Weighing platform characteristics

Measuring cells max. 4
 Weighing platform impedance $\geq 87 \Omega$
 Nominal characteristic load cell 2 mV/V or 3 mV/V

Color codes	RWMx PFA579x	PFA575x PFA459x PUA579x	DB...sTx DCS...sTx	PBA430x
Exc+	gray	gray	blue	green
Sen+	yellow	yellow	green	blue
Sig+	white	white	white	white
Sig–	brown	brown	red	red
Sen–	green	green	gray	brown
Exc–	pink	pink	black	black

CENELEC approval	cFM _{US} approval
Cables conforming to EN50039 and EN60079-14 for intrinsically safe circuits	For installation please refer to ANSI/ISA RP 12.06.01, "Installation of intrinsically safe devices in Class I hazardous areas" Cable as per country-specific regulations for intrinsically safe circuits
<ul style="list-style-type: none"> Cable inlet via earthing cable gland Cable as per installation instructions ME-72203959 	
1) Cable 4 x 2 x 0.5 mm ² + 1 x 0.5 mm ² (4 x 2 x 0.02 in ² + 1 x 0.02 in ²) shielded and twisted pair 2) Cable 3 x 2 x 0.75 mm ² (3 x 2 x 0.03 in ²) shielded and twisted pair 3) Cable 2 x 0.75 mm ² (2 x 0.03 in ²) shielded and twisted pair 4) Cable 2 x 2 x 0.5 mm ² (2 x 2 x 0.02 in ²) twisted pair and cable shield only applied to IND226x end	
5) Connection of equipotential bonding (EB) as per country-specific regulations. It must be ensured that the housings of all devices are connected to the same potential via the EB terminals. No circulating current may flow via the shielding of the intrinsically safe cables.	5) Connection of the equipotential bonding (EB) as per ANSI/NFPA 70, Article 504 and ANSI/IA RP 12.06.01 or Canadian Electrical Code C22.2. It must be ensured that the housings of all devices are connected to the same potential via the EB terminals. No circulating current may flow via the shielding of the intrinsically safe cables.
6) Mains connection in accordance with country-specific regulations; for supply voltage and frequency refer to rating plate	
7) Lay cabling securely so that it does not move and effectively protect it against damage.	
8) ATEX- and FM-approved devices in accordance with following conditions: $U_i \geq U_0$ (V_{oc}) $I_i \geq I_0$ (I_{sc}) $P_i \geq P_0$ $C_i + C_{cable} < C_0$ (C_a) $L_i + L_{cable} < L_0$ (L_a) Active input: Connection of simple electrical apparatus in accordance with NEC (NFPA 70), Sections 504.2 and 504.4	
9) For connecting devices with a maximum effective value of $U_m = 250$ V rms or DC.	
10) Use only shielded cable. Max. cable length 304 m. Cable cross section: min. 0.2 mm ² , max. 0.8 mm ²	
11) Can also be used in conjunction with the power supply unit APS768x, see terminal diagram 22006397	
12) A power supply with 24 V DC is possible in the case of device variant ACM200-DC	
Ambient temperature range: –10 °C to +40 °C (14 °F to 104 °F)	

C		11/12	Schultz					
B		11/03	Schultz					
A		09/07	Schultz		Date	Name	Scale	Designation
Edition	Change	Date	Name	Proc. by	05/07	Schultz		Terminal diagram IND226x
				Checked	05/07	Schultz		
Replacement for: /				Sheet 2/3				
Mettler-Toledo (Changzhou) Measurement Technology Ltd.								Code 72203677

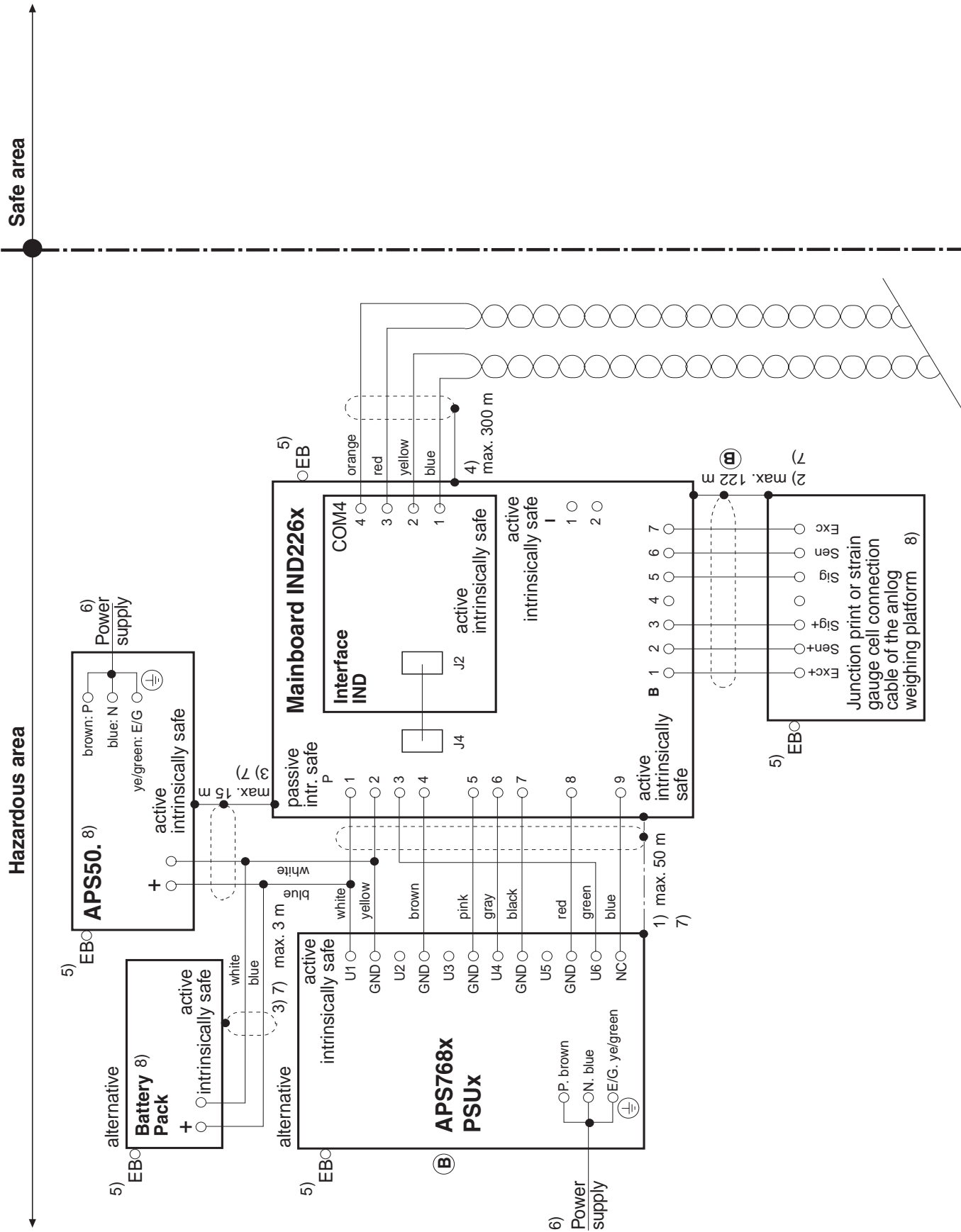

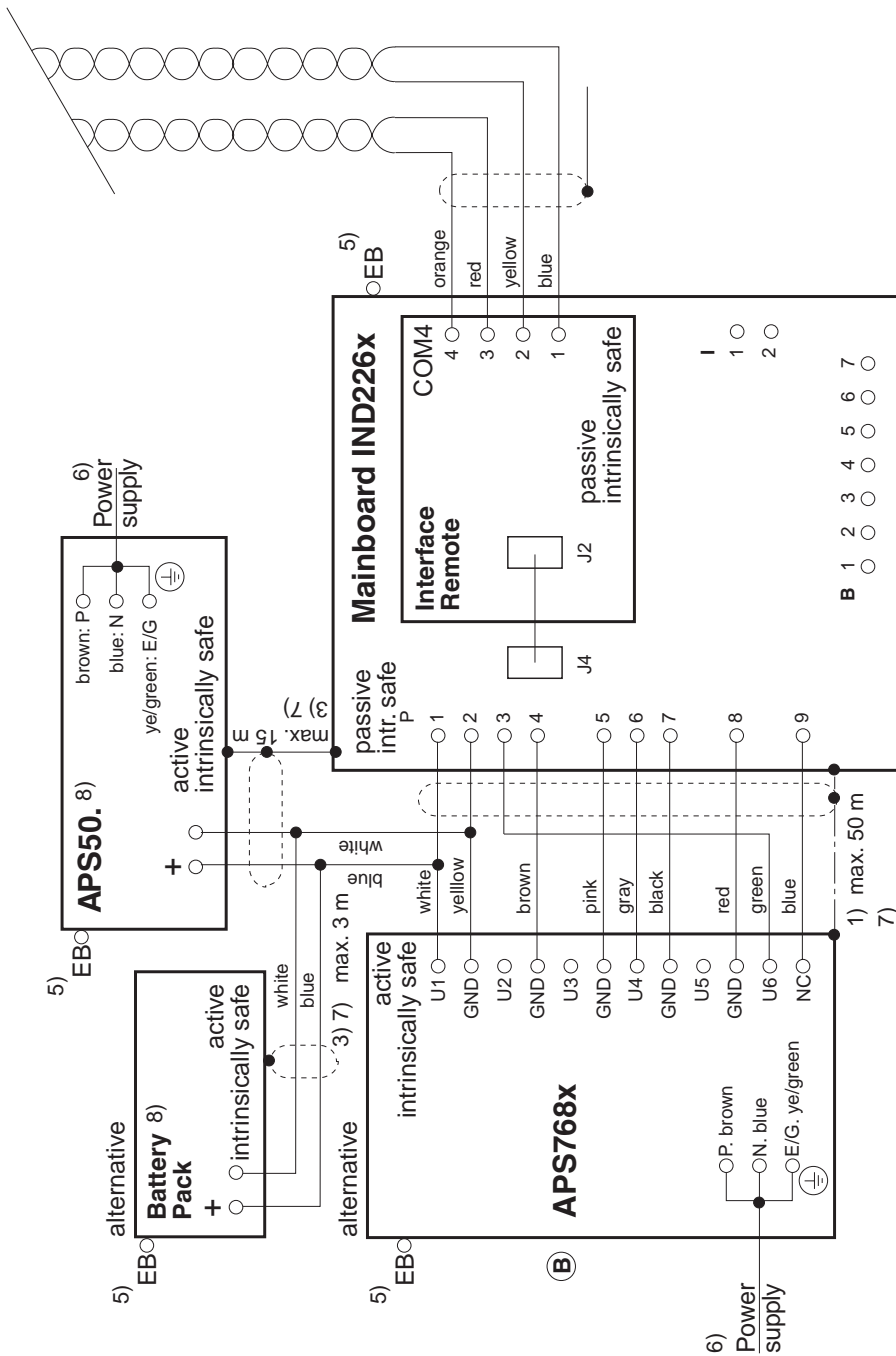

C	11/12	Schultz							
B	11/03	Schultz							
A	09/07	Schultz							
Edi- tion	Change	Date	Name						
	Replacement for:		/		Sheet 3/3				
Proc. by 05/07 Schultz Checked 05/07 Schultz									
Designation Terminal diagram IND226x									
									Code
									72203677

METTLER TOLEDO Service

Congratulations on choosing the quality and precision of METTLER TOLEDO. Proper use according to these instructions and regular calibration and maintenance by our factory-trained service team ensure dependable and accurate operation, protecting your investment. Contact us about a ServiceXXL agreement tailored to your needs and budget. We invite you to register your product at www.mt.com/productregistration so we can contact you about enhancements, updates and important notifications concerning your product.

72203958C
72203958C

Subject to technical changes © Mettler-Toledo (Changzhou) Ltd. 11/12 Printed in Germany 72203958C

Mettler-Toledo (Changzhou) Measurement Technology Ltd.

10 Kunlun Road, Changzhou Xinbei District, Jiangsu Province, P.R. China 213125

Tel. 0086-519-664-2040

Fax 0086-519-664-1991

Internet <http://www.mt.com>